



**THE DATASHEET OF  
SIT9365AI-2B2-25E322.265625**



### Description

The [SiT9365](#) is a differential MEMS XO supporting standard frequencies between 25 MHz and 325 MHz, and engineered for low-jitter applications. Utilizing SiTime's unique DualMEMS<sup>®</sup> temperature sensing and TurboCompensation<sup>®</sup> technology, the SiT9365 delivers exceptional dynamic performance by providing resistance to airflow, thermal gradients, shock and vibration. This device also integrates multiple on-chip regulators to filter power supply noise, eliminating the need for a dedicated external LDO.

The SiT9365 can be factory programmed for specific combinations of frequency, stability, voltage, and output signaling. Programmability enables designers to optimize clock configurations while eliminating long lead times and customization costs associated with quartz devices where each frequency is custom built.

Standard frequencies and programmability makes this device ideal for telecom, networking, and industrial applications that require a variety of frequencies and operate in noisy environments.

Refer to [Manufacturing Notes](#) for proper reflow profile, tape and reel dimension, and other manufacturing related information.

### Features

- 32 standard frequencies from 25 MHz to 325 MHz (For additional frequencies, refer to [SiT9366](#) and [SiT9367](#) datasheets)
- LVPECL, Low-swing LVPECL, LVDS and HCSL output signaling
- 0.1 ps RMS phase jitter (random) for Ethernet applications
- Frequency stability as low as  $\pm 10$  ppm
- Wide temperature ranges from  $-40^{\circ}\text{C}$  to  $105^{\circ}\text{C}$
- Industry-standard packages:  $3.2 \times 2.5 \text{ mm}^2$ ,  $7.0 \times 5.0 \text{ mm}^2$  and  $5.0 \times 3.2 \text{ mm}^2$  package

### Applications

- 10/40/100 Gbps Ethernet, SONET, SATA, SAS, Fibre Channel
- Telecom, networking, instrumentation, storage, servers

Related products for [automotive applications](#).

For aerospace and defense applications SiTime recommends using only [Endura™ SiT9346](#).



Order samples



Buy at SiTimeDirect



Green solutions



Lifetime warranty

### Block Diagram

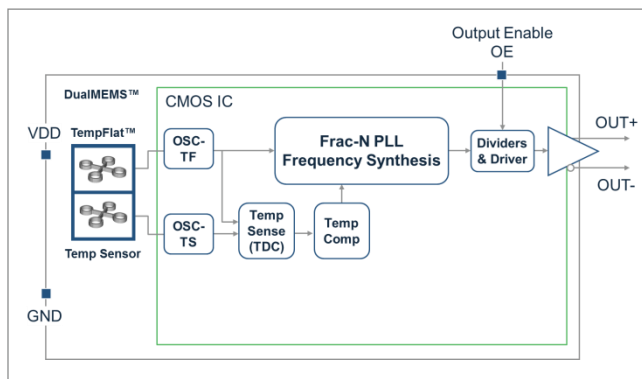

Figure 1. SiT9365 Block Diagram

### Package Pinout

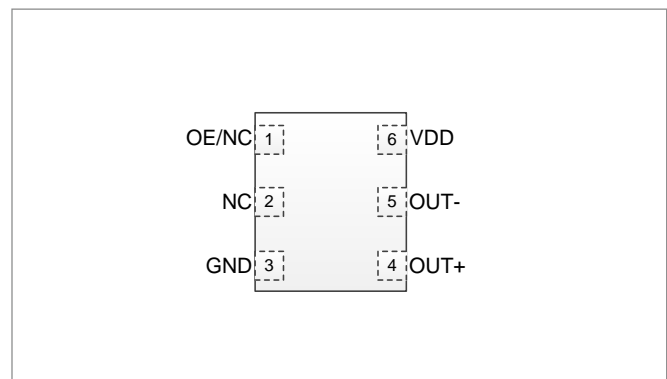
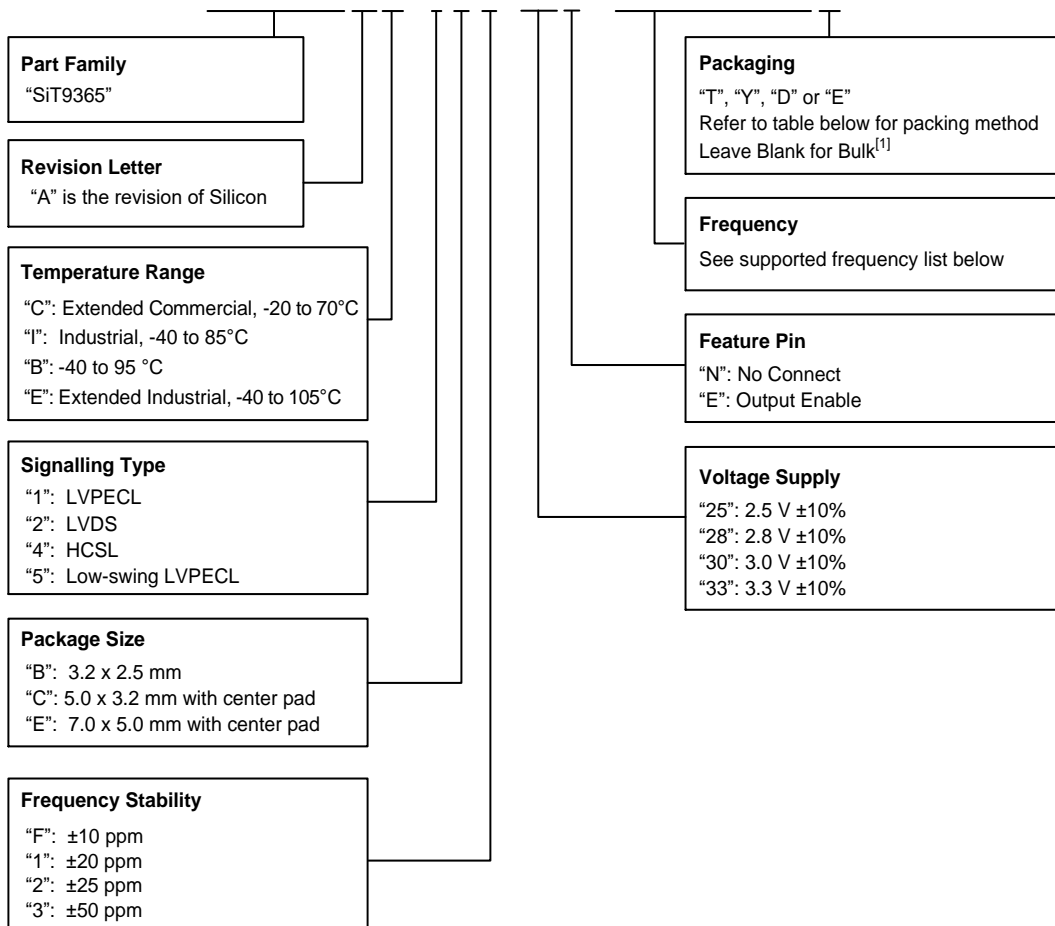

Figure 2. Pin Assignments (Top view)  
(Refer to [Table 7](#) for Pin Descriptions)

## Ordering Information

SiT9365AC-1B2-33E125.000000T



**Notes:**

1. Bulk is available for sampling only.

**Table 1. Supported Frequencies**

25.000000 MHz	30.720000 MHz	50.000000 MHz	53.125000 MHz	61.440000 MHz	62.500000 MHz	74.175824 MHz	74.250000 MHz
75.000000 MHz	77.760000 MHz	98.304000 MHz	100.000000 MHz	106.250000 MHz	122.880000 MHz	125.000000 MHz	133.333333 MHz
148.351648 MHz	150.000000 MHz	153.600000 MHz	155.520000 MHz	156.250000 MHz	159.375000 MHz	160.000000 MHz	161.132813 MHz
166.666666 MHz	168.040678 MHz	200.000000 MHz	212.500000 MHz	250.000000 MHz	300.000000 MHz	322.265625 MHz	325.000000 MHz

**Table 2. Ordering Codes for Supported Tape & Reel Packing Method**

Device Size (mm x mm)	8 mm T&R (3ku)	8 mm T&R (1ku)	12 mm T&R (3ku)	12 mm T&R (1ku)	16 mm T&R (3ku)	16 mm T&R (1ku)
7.0 x 5.0	—	—	—	—	T	Y
5.0 x 3.2			T	Y		
3.2 x 2.5	D	E			—	—

**TABLE OF CONTENTS**

Description ..... 1

Features ..... 1

Applications ..... 1

Block Diagram ..... 1

Package Pinout ..... 1

Ordering Information ..... 2

Electrical Characteristics ..... 4

Waveform Diagrams ..... 9

Timing Diagrams ..... 10

Termination Diagrams ..... 11

    LVPECL and Low-swing LVPECL ..... 11

    LVDS ..... 12

    HCSL ..... 12

Dimensions and Patterns — 3.2 x 2.5 mm<sup>2</sup> ..... 13

Dimensions and Patterns — 5.0 x 3.2 mm<sup>2</sup> ..... 13

Dimensions and Patterns — 7.0 x 5.0 mm<sup>2</sup> ..... 14

Additional Information ..... 15

Revision History ..... 16

## Electrical Characteristics

All Min and Max limits in the Electrical Characteristics tables are specified over temperature and rated operating voltage with standard output termination shown in the termination diagrams. Typical values are at 25°C and nominal supply voltage.

**Table 3. Electrical Characteristics – Common to LVPECL, Low-swing LVPECL, LVDS and HCSL (All temperature ranges)**

Parameter	Symbol	Min.	Typ.	Max.	Unit	Condition
<b>Frequency Range</b>						
Output Frequency Range	f	32 standard frequencies between 25 MHz and 325.000000 MHz			MHz	
<b>Frequency Stability</b>						
Frequency Stability	F_stab	-10	–	+10	ppm	Inclusive of initial tolerance, operating temperature, rated power supply voltage and load variations
		-20	–	+20	ppm	
		-25	–	+25	ppm	
		-50	–	+50	ppm	
First Year Aging	F_1y	-0.7	±0.4	+0.7	ppm	At 85°C
5 Year Aging	F_5y	-1.1	±0.7	+1.1	ppm	At 85°C
10 Year Aging	F_10y	-1.3	±0.8	+1.3	ppm	At 85°C
20 Year Aging	F_20y	-1.5	±1.0	+1.5	ppm	At 85°C
<b>Temperature Range</b>						
Operating Temperature Range	T_use	-20	–	+70	°C	Extended Commercial
		-40	–	+85	°C	Industrial
		-40	–	+95	°C	
		-40	–	+105	°C	Extended Industrial
<b>Supply Voltage</b>						
Supply Voltage	Vdd	2.97	3.30	3.63	V	
		2.70	3.00	3.30	V	
		2.52	2.80	3.08	V	
		2.25	2.50	2.75	V	
<b>Input Characteristics</b>						
Input Voltage High	VIH	70%	–	–	Vdd	Pin 1, OE
Input Voltage Low	VIL	–	–	30%	Vdd	Pin 1, OE
Input Pull-up Impedance	Z_in	–	100	–	kΩ	Pin 1, OE logic high or logic low
<b>Output Characteristics</b>						
Duty Cycle	DC	45	–	55	%	
<b>Startup and OE Timing</b>						
Startup Time	T_start	–	–	3.0	ms	Measured from the time Vdd reaches its rated minimum value.
OE Enable/Disable Time	T_oe	–	–	3.8	μs	f = 156.25 MHz. Measured from the time OE pin reaches rated VIH and VIL to the time clock pins reach 90% of swing and high-Z. See <a href="#">Figure 8</a> and <a href="#">Figure 9</a> .

Table 4. Electrical Characteristics – LVPECL, Low-swing LVPECL

Parameter	Symbol	Min.	Typ.	Max.	Unit	Condition
<b>Current Consumption</b>						
Current Consumption	I <sub>dd</sub>	–	–	89	mA	Excluding Load Termination Current, V <sub>dd</sub> = 3.3 V or 2.5 V
OE Disable Supply Current	I <sub>OE</sub>	–	–	58	mA	OE = Low
Output Disable Leakage Current	I <sub>leak</sub>	–	0.15	–	μA	OE = Low
Maximum Output Current	I <sub>driver</sub>	–	–	30	mA	Maximum average current drawn from OUT+ or OUT-
<b>Output Characteristics for LVPECL</b>						
Output High Voltage	VOH	V <sub>dd</sub> -1.1	–	V <sub>dd</sub> -0.7	V	See Figure 4
Output Low Voltage	VOL	V <sub>dd</sub> -1.9	–	V <sub>dd</sub> -1.5	V	See Figure 4
Output Differential Voltage Swing	V <sub>Swing</sub>	1.2	1.6	2.0	V	See Figure 5
Rise/Fall Time	Tr, Tf	–	225	290	ps	20% to 80%. See Figure 5
<b>Output Characteristics for Low-swing LVPECL</b>						
Output High Voltage	VOH	V <sub>dd</sub> -1.2	–	V <sub>dd</sub> -0.75	V	See Figure 4
Output Low Voltage	VOL	V <sub>dd</sub> -1.8	–	V <sub>dd</sub> -1.25	V	See Figure 4
Output Differential Voltage Swing	V <sub>Swing</sub>	0.4	1	1.2	V	Output frequency less than or equal to 220 MHz, See Figure 5
		0.4	1	1.6	V	Output frequency greater than 220 MHz, See Figure 5
Rise/Fall Time	Tr, Tf	–	225	290	ps	20% to 80%. See Figure 5
<b>Jitter – 7.0 x 5.0 mm Package</b>						
RMS Period Jitter <sup>[2]</sup>	T <sub>jitt</sub>	–	1.0	1.6	ps	f = 100, 156.25 or 212.5 MHz, V <sub>dd</sub> = 3.3 V or 2.5 V
RMS Phase Jitter (random)	T <sub>phj</sub>	–	0.225	0.270	ps	f = 156.25 MHz, Integration bandwidth = 12 kHz to 20 MHz, all V <sub>dd</sub> levels, includes spurs. Temperature ranges -20 to 70°C and -40 to 85°C
		–	0.225	0.300	ps	f = 156.25 MHz, Integration bandwidth = 12 kHz to 20 MHz, all V <sub>dd</sub> levels, includes spurs. Temperature ranges -40 to 95°C and -40 to 105°C
		–	0.1	–	ps	f = 156.25 or 322.265625 MHz, IEEE802.3-2005 10GbE jitter mask integration bandwidth = 1.875 MHz to 20 MHz, includes spurs, all V <sub>dd</sub> levels.
<b>Jitter – 5.0 x 3.2 mm and 3.2 x 2.5 mm Packages</b>						
RMS Period Jitter <sup>[2]</sup>	T <sub>jitt</sub>	–	1.0	1.6	ps	f = 100, 156.25 or 212.5 MHz, V <sub>dd</sub> = 3.3V or 2.5V
RMS Phase Jitter (random)		–	0.225	0.275	ps	f = 156.25 MHz, Integration bandwidth = 12 kHz to 20 MHz, all V <sub>dd</sub> levels, includes spurs. Temperature ranges -20 to 70°C and -40 to 85°C
		–	0.225	0.340	ps	f = 156.25 MHz, Integration bandwidth = 12 kHz to 20 MHz, all V <sub>dd</sub> levels, includes spurs. Temperature ranges -40 to 95°C and -40 to 105°C
		–	0.1	–	ps	f = 156.25 or 322.265625 MHz, IEEE802.3-2005 10GbE jitter mask integration bandwidth = 1.875 MHz to 20 MHz, includes spurs, all V <sub>dd</sub> levels.

**Notes:**

2. Measured according to JESD65B.

Table 5. Electrical Characteristics – LVDS

Parameter	Symbol	Min.	Typ.	Max.	Unit	Condition
<b>Current Consumption</b>						
<b>Current Consumption</b>	I <sub>dd</sub>	–	–	79	mA	Excluding Load Termination Current, V <sub>dd</sub> = 3.3 V or 2.5 V
<b>OE Disable Supply Current</b>	I <sub>OE</sub>	–	–	58	mA	OE = Low
<b>Output Disable Leakage Current</b>	I <sub>leak</sub>	–	0.15	–	μA	OE = Low
<b>Output Characteristics</b>						
<b>Differential Output Voltage</b>	V <sub>OD</sub>	300	–	450	mV	See <a href="#">Figure 6</a>
<b>Delta VOD</b>	ΔV <sub>OD</sub>	–	–	50	mV	See <a href="#">Figure 6</a>
<b>Offset Voltage</b>	V <sub>OS</sub>	1.125	–	1.375	V	See <a href="#">Figure 6</a>
<b>Delta VOS</b>	ΔV <sub>OS</sub>	–	–	50	mV	See <a href="#">Figure 6</a>
<b>Rise/Fall Time</b>	T <sub>r</sub> , T <sub>f</sub>	–	400	470	ps	Measured with 2 pF capacitive loading to GND, 20% to 80%. See <a href="#">Figure 7</a>
<b>Jitter – 7.0 x 5.0 mm Package</b>						
<b>RMS Period Jitter<sup>[3]</sup></b>	T <sub>jitt</sub>	–	1.0	1.6	ps	f = 100, 156.25 or 212.5 MHz, V <sub>dd</sub> = 3.3 V or 2.5 V
<b>RMS Phase Jitter (random)</b>	T <sub>phj</sub>	–	0.215	0.265	ps	f = 156.25 MHz, Integration bandwidth = 12 kHz to 20 MHz, all V <sub>dd</sub> levels, includes spurs. Temperature ranges -20 to 70°C and -40 to 85°C
		–	0.215	0.300	ps	f = 156.25 MHz, Integration bandwidth = 12 kHz to 20 MHz, all V <sub>dd</sub> levels, includes spurs. Temperature ranges -40 to 95°C and -40 to 105°C
		–	0.1	–	ps	f = 156.25 or 322.265625 MHz, IEEE802.3-2005 10GbE jitter mask integration bandwidth = 1.875 MHz to 20 MHz, includes spurs, all V <sub>dd</sub> levels.
<b>Jitter – 5.0 x 3.2 and 3.2 x 2.5 mm Packages</b>						
<b>RMS Period Jitter<sup>[1]</sup></b>	T <sub>jitt</sub>	–	1.0	1.6	ps	f = 100, 156.25 or 212.5 MHz, V <sub>dd</sub> = 3.3 V or 2.5 V
<b>RMS Phase Jitter (random)</b>	T <sub>phj</sub>	–	0.235	0.275	ps	f = 156.25 MHz, Integration bandwidth = 12 kHz to 20 MHz, all V <sub>dd</sub> levels, includes spurs. Temperature ranges -20 to 70°C and -40 to 85°C
		–	0.235	0.320	ps	f = 156.25 MHz, Integration bandwidth = 12 kHz to 20 MHz, all V <sub>dd</sub> levels, includes spurs. Temperature ranges -40 to 95°C and -40 to 105°C
		–	0.1	–	ps	f = 156.25 or 322.265625 MHz, IEEE802.3-2005 10GbE jitter mask integration bandwidth = 1.875 MHz to 20 MHz, includes spurs, all V <sub>dd</sub> levels.

**Notes:**

3. Measured according to JESD65B.

**Table 6. Electrical Characteristics – HCSL**

Parameter	Symbol	Min.	Typ.	Max.	Unit	Condition
<b>Current Consumption</b>						
Current Consumption	I <sub>dd</sub>	–	–	89	mA	Excluding Load Termination Current, V <sub>dd</sub> = 3.3 V or 2.5 V
OE Disable Supply Current	I <sub>OE</sub>	–	–	58	mA	OE = Low
Output Disable Leakage Current	I <sub>leak</sub>	–	0.15	–	µA	OE = Low
Maximum Output Current	I <sub>driver</sub>	–	–	35	mA	Maximum average current drawn from OUT+ or OUT-
<b>Output Characteristics</b>						
Output High Voltage	VOH	0.60	–	0.90	V	See Figure 4
Output Low Voltage	VOL	-0.05	–	0.08	V	See Figure 4
Output Differential Voltage Swing	V <sub>Swing</sub>	1.2	1.4	1.80	V	See Figure 5
Rise/Fall Time	Tr, Tf	–	360	465	ps	Measured with 2 pF capacitive loading to GND, 20% to 80%. See Figure 5
<b>Jitter – 7.0 x 5.0 mm Package</b>						
RMS Period Jitter <sup>[4]</sup>	T <sub>jitt</sub>	–	1.0	1.6	ps	f = 100, 156.25 or 212.5 MHz, V <sub>dd</sub> = 3.3 V or 2.5 V
RMS Phase Jitter (random)	T <sub>phj</sub>	–	0.220	0.270	ps	f = 156.25 MHz, Integration bandwidth = 12 kHz to 20 MHz, all V <sub>dd</sub> levels, includes spurs. Temperature ranges -20 to 70°C and -40 to 85°C
		–	0.220	0.300	ps	f = 156.25 MHz, Integration bandwidth = 12 kHz to 20 MHz, all V <sub>dd</sub> levels, includes spurs. Temperature ranges -40 to 95°C and -40 to 105°C
		–	0.1	–	ps	f = 156.25 or 322.265625 MHz, IEEE802.3-2005 10GbE jitter mask integration bandwidth = 1.875 MHz to 20 MHz, includes spurs, all V <sub>dd</sub> levels.
<b>Jitter – 5.0 x 3.2 and 3.2 x 2.5 mm Packages</b>						
RMS Period Jitter <sup>[4]</sup>	T <sub>jitt</sub>	–	1.0	1.6	ps	f = 100, 156.25 or 212.5 MHz, V <sub>dd</sub> = 3.3 V or 2.5 V
RMS Phase Jitter (random)	T <sub>phj</sub>	–	0.230	0.275	ps	f = 156.25 MHz, Integration bandwidth = 12 kHz to 20 MHz, all V <sub>dd</sub> levels, includes spurs. Temperature ranges -20 to 70°C and -40 to 85°C
		–	0.230	0.340	ps	f = 156.25 MHz, Integration bandwidth = 12 kHz to 20 MHz, all V <sub>dd</sub> levels, includes spurs. Temperature ranges -40 to 95°C and -40 to 105°C
		–	0.1	–	ps	f = 156.25 or 322.265625 MHz, IEEE802.3-2005 10GbE jitter mask integration bandwidth = 1.875 MHz to 20 MHz, includes spurs, all V <sub>dd</sub> levels.

**Notes:**

- 4. Measured according to JESD65B.

**Table 7. Pin Description**

Pin	Map	Functionality	
1	OE/NC	Output Enable (OE)	H <sup>[5]</sup> : specified frequency output L: output is high impedance
		Non Connect (NC)	H or L or Open: No effect on output frequency or other device functions
2	NC	NA	No Connect; Leave it floating or connect to GND for better heat dissipation
3	GND	Power	VDD Power Supply Ground
4	OUT+	Output	Oscillator output
5	OUT-	Output	Complementary oscillator output
6 <sub>5</sub>	VDD	Power	Power supply voltage <sup>[6]</sup>

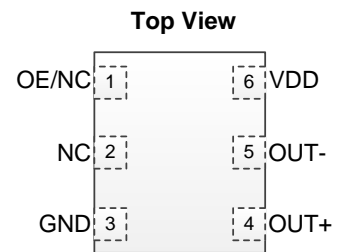

**Figure 3. Pin Assignments**

**Notes:**

- 5. In OE mode, a pull-up resistor of 10 kΩ or less is recommended if pin 1 is not externally driven.
- 6. A capacitor of value 0.1 µF or higher between VDD and GND is required. An additional 10 µF capacitor between VDD and GND is required for the best phase jitter performance.

**Table 8. Absolute Maximum Ratings**

Attempted operation outside the absolute maximum ratings may cause permanent damage to the part. Actual performance of the IC is only guaranteed within the operational specifications, not at absolute maximum ratings.

Parameter	Min.	Max.	Unit
Vdd	-0.5	4.0	V
VIH		Vdd + 0.3V	V
VIL	-0.3		V
Storage Temperature	-65	150	°C
Maximum Junction Temperature		130	°C
Soldering Temperature (follow standard Pb-free soldering guidelines)		260	°C

**Table 9. Thermal Considerations<sup>[7]</sup>**

Package	$\theta_{JA}$ , 4 Layer Board (°C/W)	$\theta_{JC}$ , Bottom (°C/W)
3225, 6-pin	80	30
5032, 6-pin	53	20
7050, 6-pin	52	19

**Notes:**

7. Refer to JE51 for  $\theta_{JA}$  and  $\theta_{JC}$  definitions, and reference layout used to determine the  $\theta_{JA}$  and  $\theta_{JC}$  values in the above table.

**Table 10. Maximum Operating Junction Temperature<sup>[8]</sup>**

Max Operating Temperature (ambient)	Maximum Operating Junction Temperature
70°C	95°C
85°C	110°C
95°C	120°C
105°C	130°C

**Notes:**

8. Datasheet specifications are not guaranteed if junction temperature exceeds the maximum operating junction temperature.

**Table 11. Environmental Compliance**

Parameter	Test Conditions	Value	Unit
Mechanical Shock Resistance	MIL-STD-883F, Method 2002	10,000	g
Mechanical Vibration Resistance	MIL-STD-883F, Method 2007	70	g
Soldering Temperature (follow standard Pb free soldering guidelines)	MIL-STD-883F, Method 2003	260	°C
Moisture Sensitivity Level	MSL1 @ 260°C		
Electrostatic Discharge (HBM)	HBM, JESD22-A114	2,000	V
Charge-Device Model ESD Protection	JESD220C101	750	V
Latch-up Tolerance	JESD78 Compliant		

### Waveform Diagrams

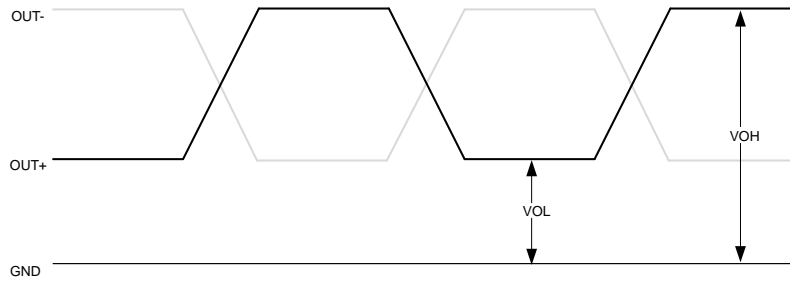

Figure 4. LVPECL, Low-swing LVPECL, and HCSL Voltage Levels per Differential Pin (i.e. OUT+, or OUT-)

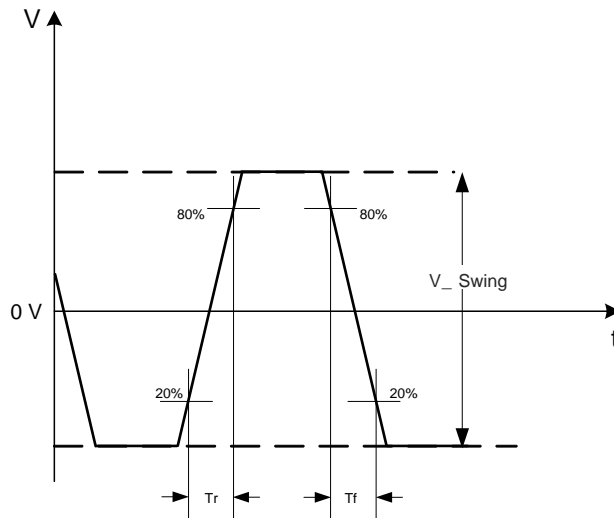
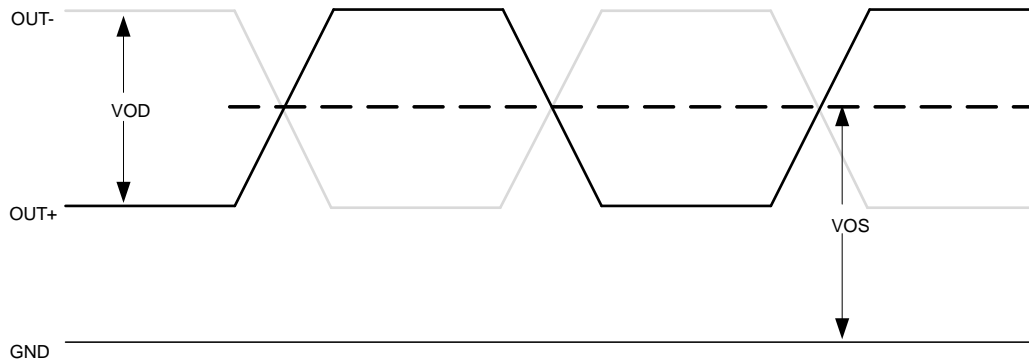
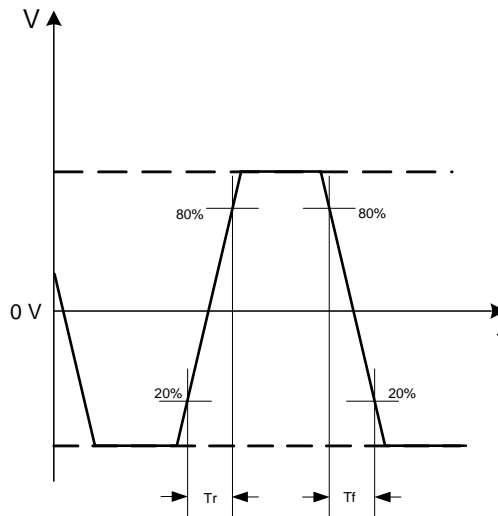

Figure 5. LVPECL, Low-swing LVPECL, and HCSL Voltage Levels Across Differential Pair (i.e. OUT+ minus OUT-)

### Waveform Diagrams (continued)

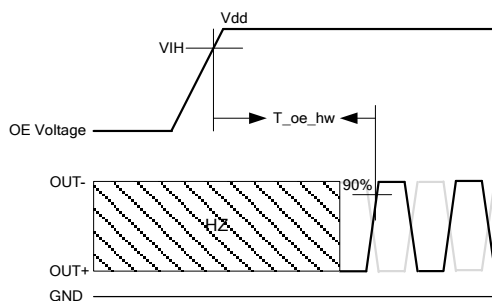

**Figure 6. LVDS Voltage Levels per Differential Pin (i.e. OUT+, or OUT-)**

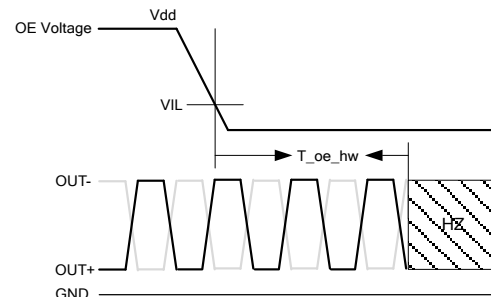

**Figure 7. LVDS Differential Waveform (i.e. OUT+ minus OUT-)**

### Timing Diagrams



**Figure 8. Hardware OE Enable Timing**



**Figure 9. Hardware OE Disable Timing**

## Termination Diagrams

### LVPECL and Low-swing LVPECL

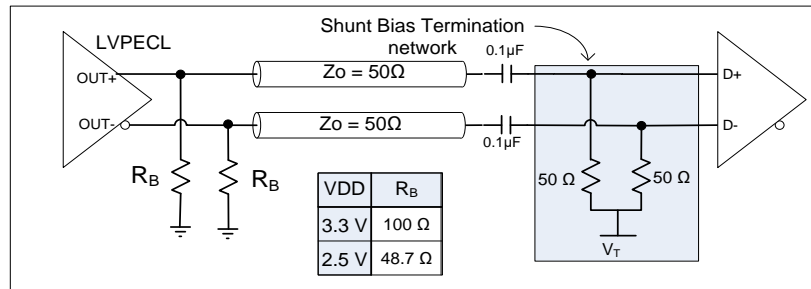

Figure 10. LVPECL and Low-swing LVPECL with AC-coupled Termination

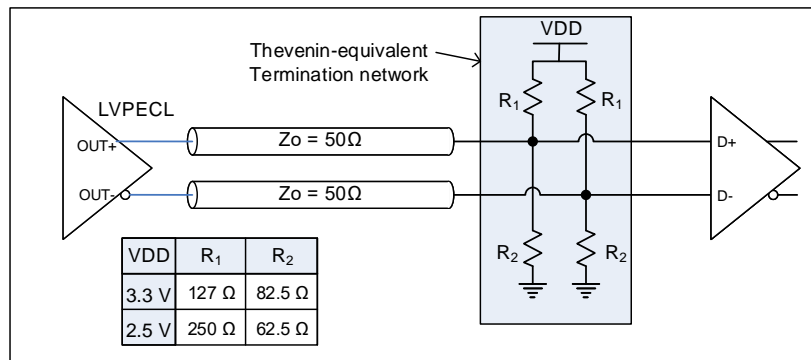

Figure 11. LVPECL and Low-swing LVPECL DC-coupled Load Termination with Thevenin Equivalent Network

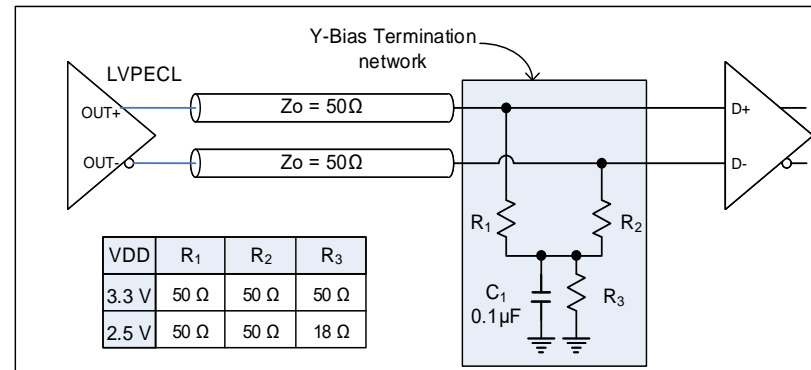

Figure 12. LVPECL and Low-swing LVPECL with Y-Bias Termination

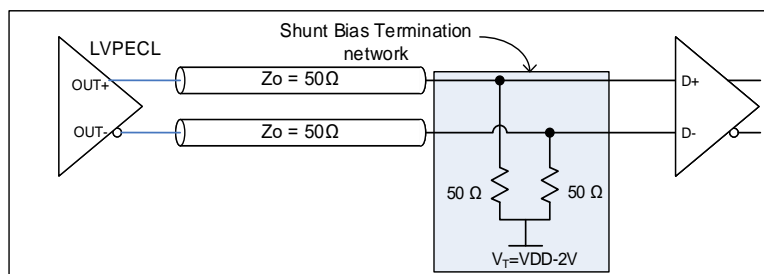

Figure 13. LVPECL and Low-swing LVPECL with DC-coupled Parallel Shunt Load Termination

### Termination Diagrams (continued)

#### LVDS

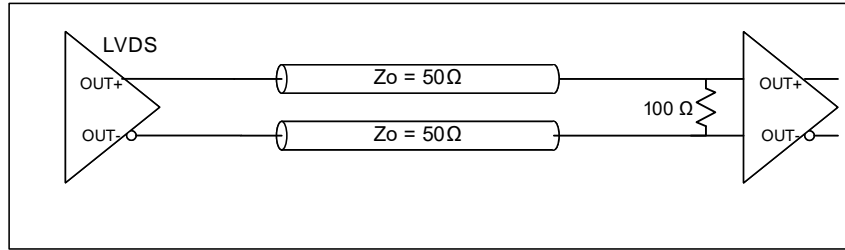

Figure 14. LVDS Single DC Termination at the Load

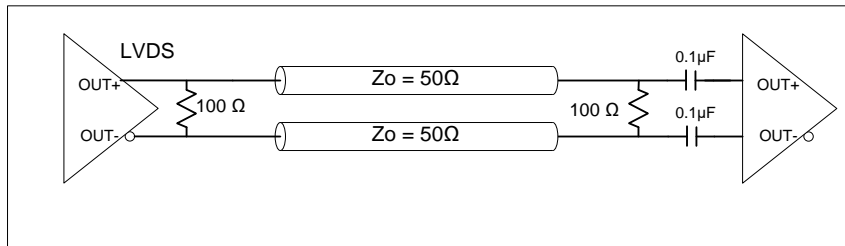

Figure 15. LVDS double AC Termination with Capacitor Close to the Load

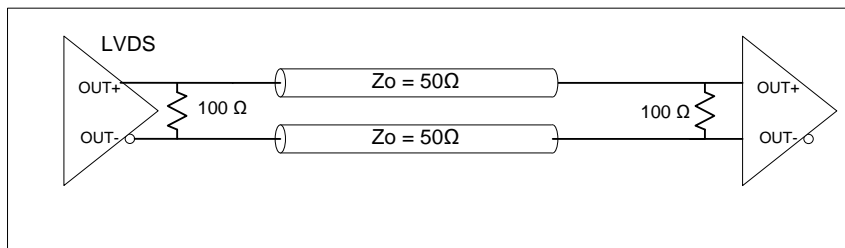

Figure 16. LVDS Double DC Termination

#### HCSL

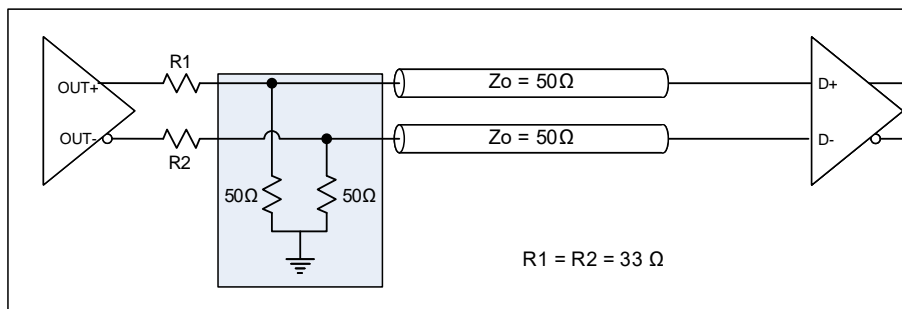

Figure 17. HCSL Interface Termination

### Dimensions and Patterns — 3.2 x 2.5 mm<sup>2</sup>

Package Size – Dimensions (Unit: mm) <sup>[9]</sup>	Recommended Land Pattern (Unit: mm) <sup>[10]</sup>																																																																																	
<p><b>3.2 x 2.5 x 0.85 mm</b></p> <table border="1" style="width:100%; border-collapse: collapse; margin-top: 10px;"> <thead> <tr> <th></th> <th>SYMBOL</th> <th>MIN</th> <th>NOM</th> <th>MAX</th> </tr> </thead> <tbody> <tr> <td>TOTAL THICKNESS</td> <td>A</td> <td>0.800</td> <td>0.850</td> <td>0.900</td> </tr> <tr> <td>STAND OFF</td> <td>A1</td> <td>0.000</td> <td>0.035</td> <td>0.050</td> </tr> <tr> <td rowspan="2">BODY SIZE</td> <td>X</td> <td colspan="3">3.200 BSC</td> </tr> <tr> <td>Y</td> <td colspan="3">2.500 BSC</td> </tr> <tr> <td>LEAD WIDTH</td> <td>b</td> <td>0.550</td> <td>0.600</td> <td>0.650</td> </tr> <tr> <td rowspan="2">LEAD LENGTH</td> <td>L</td> <td>0.650</td> <td>0.700</td> <td>0.750</td> </tr> <tr> <td>L1</td> <td colspan="3">0.800 REF</td> </tr> <tr> <td>LEAD PITCH</td> <td>e</td> <td colspan="3">1.100 BSC</td> </tr> <tr> <td>PACKAGE TOLERANCE</td> <td>aaa</td> <td colspan="3">0.100</td> </tr> <tr> <td>MOLD FLATNESS</td> <td>bbb</td> <td colspan="3">0.100</td> </tr> <tr> <td>COPLANARITY</td> <td>ccc</td> <td colspan="3">0.080</td> </tr> <tr> <td>DIMPLE WIDTH</td> <td>T</td> <td colspan="3">0.150 REF</td> </tr> <tr> <td>DIMPLE LENGTH</td> <td>P</td> <td colspan="3">0.150 REF</td> </tr> <tr> <td>DIMPLE DEPTH</td> <td>A2</td> <td colspan="3">0.100 REF</td> </tr> </tbody> </table> <p>Notes 1. All dimensions are in millimeters</p> <div style="text-align: right; margin-top: 10px;"> <table border="1" style="width: 80%; border-collapse: collapse;"> <thead> <tr> <th colspan="2">Package Outline</th> </tr> </thead> <tbody> <tr> <td>6L PQFD</td> <td>POD-038-PQFO-006-C03225</td> </tr> <tr> <td>3.200x2.500x0.850 mm</td> <td></td> </tr> <tr> <td>2021/07/15 Rev C00</td> <td></td> </tr> </tbody> </table> </div>		SYMBOL	MIN	NOM	MAX	TOTAL THICKNESS	A	0.800	0.850	0.900	STAND OFF	A1	0.000	0.035	0.050	BODY SIZE	X	3.200 BSC			Y	2.500 BSC			LEAD WIDTH	b	0.550	0.600	0.650	LEAD LENGTH	L	0.650	0.700	0.750	L1	0.800 REF			LEAD PITCH	e	1.100 BSC			PACKAGE TOLERANCE	aaa	0.100			MOLD FLATNESS	bbb	0.100			COPLANARITY	ccc	0.080			DIMPLE WIDTH	T	0.150 REF			DIMPLE LENGTH	P	0.150 REF			DIMPLE DEPTH	A2	0.100 REF			Package Outline		6L PQFD	POD-038-PQFO-006-C03225	3.200x2.500x0.850 mm		2021/07/15 Rev C00		<p><b>3.2 x 2.5 x 0.85 mm</b></p>
	SYMBOL	MIN	NOM	MAX																																																																														
TOTAL THICKNESS	A	0.800	0.850	0.900																																																																														
STAND OFF	A1	0.000	0.035	0.050																																																																														
BODY SIZE	X	3.200 BSC																																																																																
	Y	2.500 BSC																																																																																
LEAD WIDTH	b	0.550	0.600	0.650																																																																														
LEAD LENGTH	L	0.650	0.700	0.750																																																																														
	L1	0.800 REF																																																																																
LEAD PITCH	e	1.100 BSC																																																																																
PACKAGE TOLERANCE	aaa	0.100																																																																																
MOLD FLATNESS	bbb	0.100																																																																																
COPLANARITY	ccc	0.080																																																																																
DIMPLE WIDTH	T	0.150 REF																																																																																
DIMPLE LENGTH	P	0.150 REF																																																																																
DIMPLE DEPTH	A2	0.100 REF																																																																																
Package Outline																																																																																		
6L PQFD	POD-038-PQFO-006-C03225																																																																																	
3.200x2.500x0.850 mm																																																																																		
2021/07/15 Rev C00																																																																																		

### Dimensions and Patterns — 5.0 x 3.2 mm<sup>2</sup>

Package Size – Dimensions (Unit: mm) <sup>[9]</sup>	Recommended Land Pattern (Unit: mm) <sup>[10]</sup>																																																																																										
<p><b>5.0 x 3.2 x 0.85 mm<sup>[11]</sup></b></p> <table border="1" style="width:100%; border-collapse: collapse; margin-top: 10px;"> <thead> <tr> <th></th> <th>SYMBOL</th> <th>MIN</th> <th>NOM</th> <th>MAX</th> </tr> </thead> <tbody> <tr> <td>TOTAL THICKNESS</td> <td>A</td> <td>0.800</td> <td>0.850</td> <td>0.900</td> </tr> <tr> <td>STAND OFF</td> <td>A1</td> <td>0.000</td> <td>0.035</td> <td>0.050</td> </tr> <tr> <td rowspan="2">BODY SIZE</td> <td>X</td> <td colspan="3">5.000 BSC</td> </tr> <tr> <td>Y</td> <td colspan="3">3.200 BSC</td> </tr> <tr> <td rowspan="2">EP SIZE</td> <td>X</td> <td>3.100</td> <td>3.200</td> <td>3.300</td> </tr> <tr> <td>Y</td> <td>0.500</td> <td>0.600</td> <td>0.700</td> </tr> <tr> <td>LEAD WIDTH</td> <td>b</td> <td>0.590</td> <td>0.640</td> <td>0.690</td> </tr> <tr> <td rowspan="2">LEAD LENGTH</td> <td>L</td> <td>0.850</td> <td>0.900</td> <td>0.950</td> </tr> <tr> <td>L1</td> <td colspan="3">1.000 REF</td> </tr> <tr> <td>LEAD PITCH</td> <td>e</td> <td colspan="3">1.270 BSC</td> </tr> <tr> <td>PACKAGE TOLERANCE</td> <td>aaa</td> <td colspan="3">0.100</td> </tr> <tr> <td>MOLD FLATNESS</td> <td>bbb</td> <td colspan="3">0.100</td> </tr> <tr> <td>COPLANARITY</td> <td>ccc</td> <td colspan="3">0.080</td> </tr> <tr> <td>DIMPLE WIDTH</td> <td>T</td> <td colspan="3">0.300 REF</td> </tr> <tr> <td>DIMPLE LENGTH</td> <td>P</td> <td colspan="3">0.150 REF</td> </tr> <tr> <td>DIMPLE DEPTH</td> <td>A2</td> <td colspan="3">0.100 REF</td> </tr> </tbody> </table> <p>Notes 1. Dimensioning and tolerancing conform to ASME Y14.5-2009 2. All dimensions are in millimeters</p> <div style="text-align: right; margin-top: 10px;"> <table border="1" style="width: 80%; border-collapse: collapse;"> <thead> <tr> <th colspan="2">Package Outline</th> </tr> </thead> <tbody> <tr> <td>6L PQFV</td> <td>POD-PQFV-006-C03032-039</td> </tr> <tr> <td>5.000x3.200x0.850 mm</td> <td></td> </tr> <tr> <td>2019/03/13 Rev B00</td> <td></td> </tr> </tbody> </table> </div>		SYMBOL	MIN	NOM	MAX	TOTAL THICKNESS	A	0.800	0.850	0.900	STAND OFF	A1	0.000	0.035	0.050	BODY SIZE	X	5.000 BSC			Y	3.200 BSC			EP SIZE	X	3.100	3.200	3.300	Y	0.500	0.600	0.700	LEAD WIDTH	b	0.590	0.640	0.690	LEAD LENGTH	L	0.850	0.900	0.950	L1	1.000 REF			LEAD PITCH	e	1.270 BSC			PACKAGE TOLERANCE	aaa	0.100			MOLD FLATNESS	bbb	0.100			COPLANARITY	ccc	0.080			DIMPLE WIDTH	T	0.300 REF			DIMPLE LENGTH	P	0.150 REF			DIMPLE DEPTH	A2	0.100 REF			Package Outline		6L PQFV	POD-PQFV-006-C03032-039	5.000x3.200x0.850 mm		2019/03/13 Rev B00		<p><b>5.0 x 3.2 x 0.85 mm<sup>[11]</sup></b></p>
	SYMBOL	MIN	NOM	MAX																																																																																							
TOTAL THICKNESS	A	0.800	0.850	0.900																																																																																							
STAND OFF	A1	0.000	0.035	0.050																																																																																							
BODY SIZE	X	5.000 BSC																																																																																									
	Y	3.200 BSC																																																																																									
EP SIZE	X	3.100	3.200	3.300																																																																																							
	Y	0.500	0.600	0.700																																																																																							
LEAD WIDTH	b	0.590	0.640	0.690																																																																																							
LEAD LENGTH	L	0.850	0.900	0.950																																																																																							
	L1	1.000 REF																																																																																									
LEAD PITCH	e	1.270 BSC																																																																																									
PACKAGE TOLERANCE	aaa	0.100																																																																																									
MOLD FLATNESS	bbb	0.100																																																																																									
COPLANARITY	ccc	0.080																																																																																									
DIMPLE WIDTH	T	0.300 REF																																																																																									
DIMPLE LENGTH	P	0.150 REF																																																																																									
DIMPLE DEPTH	A2	0.100 REF																																																																																									
Package Outline																																																																																											
6L PQFV	POD-PQFV-006-C03032-039																																																																																										
5.000x3.200x0.850 mm																																																																																											
2019/03/13 Rev B00																																																																																											

**Notes:**

9. Top Marking: Y denotes manufacturing origin and XXXX denotes manufacturing lot number. The value of “Y” will depend on the assembly location of the device.
10. A capacitor of value 0.1 μF or higher between VDD and GND is required. An additional 10 μF capacitor between VDD and GND is required for the best phase jitter performance.
11. The center pad has no electrical function. Soldering down the center pad to the GND is recommended for best thermal dissipation, but is optional.

## Dimensions and Patterns — 7.0 x 5.0 mm<sup>2</sup>

Package Size – Dimensions (Unit: mm) <sup>[12]</sup>	Recommended Land Pattern (Unit: mm) <sup>[13]</sup>																																																																																											
<p><b>7.0 x 5.0 x 0.85 mm<sup>[14]</sup></b></p> <table border="1" style="width: 100%; border-collapse: collapse; margin-top: 10px;"> <thead> <tr> <th></th> <th>SYMBOL</th> <th>MIN</th> <th>NOM</th> <th>MAX</th> </tr> </thead> <tbody> <tr> <td>TOTAL THICKNESS</td> <td>A</td> <td>0.800</td> <td>0.850</td> <td>0.900</td> </tr> <tr> <td>STAND OFF</td> <td>A1</td> <td>0.000</td> <td>0.035</td> <td>0.050</td> </tr> <tr> <td rowspan="2">BODY SIZE</td> <td>X</td> <td colspan="3">7.000 BSC</td> </tr> <tr> <td>Y</td> <td colspan="3">5.000 BSC</td> </tr> <tr> <td rowspan="2">EP SIZE</td> <td>X</td> <td>3.400</td> <td>3.500</td> <td>3.600</td> </tr> <tr> <td>Y</td> <td>1.400</td> <td>1.500</td> <td>1.600</td> </tr> <tr> <td>LEAD WIDTH</td> <td>b</td> <td>1.350</td> <td>1.400</td> <td>1.450</td> </tr> <tr> <td>LEAD LENGTH</td> <td>L</td> <td>0.850</td> <td>0.900</td> <td>0.950</td> </tr> <tr> <td>LEAD PITCH</td> <td>L1</td> <td colspan="3">1.000 REF</td> </tr> <tr> <td>LEAD PITCH</td> <td>e</td> <td colspan="3">2.540 BSC</td> </tr> <tr> <td>PACKAGE TOLERANCE</td> <td>aaa</td> <td colspan="3">0.100</td> </tr> <tr> <td>MOLD FLATNESS</td> <td>bbb</td> <td colspan="3">0.100</td> </tr> <tr> <td>COPLANARITY</td> <td>ccc</td> <td colspan="3">0.080</td> </tr> <tr> <td>DIMPLE WIDTH</td> <td>T</td> <td colspan="3">0.300 REF</td> </tr> <tr> <td>DIMPLE LENGTH</td> <td>P</td> <td colspan="3">0.150 REF</td> </tr> <tr> <td>DIMPLE DEPTH</td> <td>A2</td> <td colspan="3">0.100 REF</td> </tr> </tbody> </table> <p>Notes</p> <ol style="list-style-type: none"> <li>Dimensioning and tolerancing conform to ASME Y14.5-2009</li> <li>All dimensions are in millimeters</li> </ol> <table border="1" style="width: 100%; border-collapse: collapse; margin-top: 10px;"> <thead> <tr> <th colspan="2" style="text-align: center;">Package Outline</th> </tr> </thead> <tbody> <tr> <td style="text-align: center;">6L PQFV</td> <td style="text-align: center;">POD-PQFV-006-C07050-037</td> </tr> <tr> <td colspan="2" style="text-align: center;">7.000x5.000x0.850 mm</td> </tr> <tr> <td style="text-align: center;">2019/03/13 Rev 800</td> <td style="text-align: center;"></td> </tr> </tbody> </table>		SYMBOL	MIN	NOM	MAX	TOTAL THICKNESS	A	0.800	0.850	0.900	STAND OFF	A1	0.000	0.035	0.050	BODY SIZE	X	7.000 BSC			Y	5.000 BSC			EP SIZE	X	3.400	3.500	3.600	Y	1.400	1.500	1.600	LEAD WIDTH	b	1.350	1.400	1.450	LEAD LENGTH	L	0.850	0.900	0.950	LEAD PITCH	L1	1.000 REF			LEAD PITCH	e	2.540 BSC			PACKAGE TOLERANCE	aaa	0.100			MOLD FLATNESS	bbb	0.100			COPLANARITY	ccc	0.080			DIMPLE WIDTH	T	0.300 REF			DIMPLE LENGTH	P	0.150 REF			DIMPLE DEPTH	A2	0.100 REF			Package Outline		6L PQFV	POD-PQFV-006-C07050-037	7.000x5.000x0.850 mm		2019/03/13 Rev 800		<p><b>7.0 x 5.0 x 0.85 mm<sup>[14]</sup></b></p> <p><b>Note:</b> Circles in center pad are thermal vias, recommended to improve thermal performance</p>
	SYMBOL	MIN	NOM	MAX																																																																																								
TOTAL THICKNESS	A	0.800	0.850	0.900																																																																																								
STAND OFF	A1	0.000	0.035	0.050																																																																																								
BODY SIZE	X	7.000 BSC																																																																																										
	Y	5.000 BSC																																																																																										
EP SIZE	X	3.400	3.500	3.600																																																																																								
	Y	1.400	1.500	1.600																																																																																								
LEAD WIDTH	b	1.350	1.400	1.450																																																																																								
LEAD LENGTH	L	0.850	0.900	0.950																																																																																								
LEAD PITCH	L1	1.000 REF																																																																																										
LEAD PITCH	e	2.540 BSC																																																																																										
PACKAGE TOLERANCE	aaa	0.100																																																																																										
MOLD FLATNESS	bbb	0.100																																																																																										
COPLANARITY	ccc	0.080																																																																																										
DIMPLE WIDTH	T	0.300 REF																																																																																										
DIMPLE LENGTH	P	0.150 REF																																																																																										
DIMPLE DEPTH	A2	0.100 REF																																																																																										
Package Outline																																																																																												
6L PQFV	POD-PQFV-006-C07050-037																																																																																											
7.000x5.000x0.850 mm																																																																																												
2019/03/13 Rev 800																																																																																												

**Notes:**

- Top Marking: Y denotes manufacturing origin and XXXX denotes manufacturing lot number. The value of “Y” will depend on the assembly location of the device.
- A capacitor of value 0.1  $\mu$ F or higher between VDD and GND is required. An additional 10  $\mu$ F capacitor between VDD and GND is required for the best phase jitter performance.
- The center pad has no electrical function. Soldering down the center pad to the GND is recommended for best thermal dissipation, but is optional.

## Additional Information

**Table 12. Additional Information**

Document	Description	Download Link
<b>ECCN #: EAR99</b>	Five character designation used on the commerce Control List (CCL) to identify dual use items for export control purposes.	—
<b>HTS Classification Code: 8542.39.0000</b>	A Harmonized Tariff Schedule (HTS) code developed by the World Customs Organization to classify/define internationally traded goods.	—
<b>Part number Generator</b>	Tool used to create the part number based on desired features.	<a href="https://www.sitime.com/part-number-generator">https://www.sitime.com/part-number-generator</a>
<b>Manufacturing Notes</b>	Tape & Reel dimension, reflow profile and other manufacturing related info	<a href="https://www.sitime.com/sites/default/files/gated/Manufacturing-Notes-for-SiTime-Products.pdf">https://www.sitime.com/sites/default/files/gated/Manufacturing-Notes-for-SiTime-Products.pdf</a>
<b>Qualification Reports</b>	RoHS report, reliability reports, composition reports	<a href="http://www.sitime.com/support/quality-and-reliability">http://www.sitime.com/support/quality-and-reliability</a>
<b>Performance Reports</b>	Additional performance data such as phase noise, current consumption and jitter for selected frequencies	<a href="http://www.sitime.com/support/performance-measurement-report">http://www.sitime.com/support/performance-measurement-report</a>
<b>Termination Techniques</b>	Termination design recommendations	<a href="http://www.sitime.com/support/application-notes">http://www.sitime.com/support/application-notes</a>
<b>Layout Techniques</b>	Layout recommendations	<a href="http://www.sitime.com/support/application-notes">http://www.sitime.com/support/application-notes</a>
<b>Evaluation Boards</b>	SiT6085/6EB rev. 3.0, SiT6085EB rev.3.1 and SiT6097EB rev. 2.0 Evaluation Boards for Differential Oscillators User Manual	<a href="https://www.sitime.com/support/user-guides">https://www.sitime.com/support/user-guides</a>

## Revision History

**Table 13. Revision History**

Revision	Release Date	Change Summary
1.0	6-Sep-2017	Final release
1.04	17-Apr-2018	Added 5032 package Added -40 to 95°C and -40 to 105°C temperature ranges Corrected minor errors  Added Additional Information Table
1.05	3-Jul-2018	Performed minor edits and updated Ordering Information
1.06	25-Oct-2018	Removed "Contact SiTime" for $\pm 10$ ppm
1.07	30-Jul-2019	Updated package Dimensions Drawings Updated Table 9 Thermal Considerations for 5032 package Updated Table 3 specification for First Year Aging Added 5, 10, and 20 year aging specs Added Evaluation Boards SiT6085EB reference in Table 12 Rearranged layout, added Description, Block Diagram and TOC Tightened LVDS minimum VOD specification Added HTS code Added low-swing LVPECL package code and specifications
1.08	17-Aug-2019	Formatting changes
1.09	9-Mar-2021	Updated L1 and Dimple Width package dimensions for 3.2 x 2.5 mm package Updated trademarks, hyperlinks and changed rev table date format
1.1	20-Jul-2021	Updated pin direction in package dimensions for 3.2 x 2.5 mm package
1.11	1-Jan-2023	Updated company disclaimer, links, references and icons

**SiTime Corporation**, 5451 Patrick Henry Drive, Santa Clara, CA 95054, USA | **Phone:** +1-408-328-4400 | **Fax:** +1-408-328-4439

© SiTime Corporation 2017-2023. The information contained herein is subject to change at any time without notice. SiTime assumes no responsibility or liability for any loss, damage or defect of a Product which is caused in whole or in part by (i) use of any circuitry other than circuitry embodied in a SiTime product, (ii) misuse or abuse including static discharge, neglect or accident, (iii) unauthorized modification or repairs which have been soldered or altered during assembly and are not capable of being tested by SiTime under its normal test conditions, or (iv) improper installation, storage, handling, warehousing or transportation, or (v) being subjected to unusual physical, thermal, or electrical stress.

**Disclaimer:** SiTime makes no warranty of any kind, express or implied, with regard to this material, and specifically disclaims any and all express or implied warranties, either in fact or by operation of law, statutory or otherwise, including the implied warranties of merchantability and fitness for use or a particular purpose, and any implied warranty arising from course of dealing or usage of trade, as well as any common-law duties relating to accuracy or lack of negligence, with respect to this material, any SiTime product and any product documentation. This product is not suitable or intended to be used in a life support application or component, to operate nuclear facilities, in military or aerospace applications, or in other mission critical applications where human life may be involved or at stake. All sales are made conditioned upon compliance with the critical uses policy set forth below.

#### CRITICAL USE EXCLUSION POLICY

BUYER AGREES NOT TO USE SITIME'S PRODUCTS FOR ANY APPLICATION OR IN ANY COMPONENTS: USED IN LIFE SUPPORT DEVICES, TO OPERATE NUCLEAR FACILITIES, FOR MILITARY OR AEROSPACE USE, OR IN OTHER MISSION CRITICAL APPLICATIONS OR COMPONENTS WHERE HUMAN LIFE OR PROPERTY MAY BE AT STAKE.

For aerospace and defense applications, SiTime recommends using only [Endura™ ruggedized products](#).

SiTime owns all rights, title and interest to the intellectual property related to SiTime's products, including any software, firmware, copyright, patent, or trademark. The sale of SiTime products does not convey or imply any license under patent or other rights. SiTime retains the copyright and trademark rights in all documents, catalogs and plans supplied pursuant to or ancillary to the sale of products or services by SiTime. Unless otherwise agreed to in writing by SiTime, any reproduction, modification, translation, compilation, or representation of this material shall be strictly prohibited.

## Looking for pricing, stock, or lifecycle information?

Click below to explore more details on WIN SOURCE:

 [View SIT9365AI-2B2-25E322.265625 on WIN SOURCE](#)

 [SiTIME Information](#)

## Optimize Your Supply Chain with WIN SOURCE Solutions

-  Global Sourcing Solution
-  Obsolete Management
-  Cost Control Management
-  Shortage Management
-  Alternative Solution
-  Excess Inventory Management