



**THE DATASHEET OF
MCZ33903DP5EKR2**



SBC Gen2 with CAN high speed and LIN interface

The 33903/4/5 is the second generation family of the System Basis Chip (SBC). It combines several features and enhances present module designs. The device works as an advanced power management unit for the MCU with additional integrated circuits such as sensors and CAN transceivers. It has a built-in enhanced high-speed CAN interface (ISO11898-2 and -5) with local and bus failure diagnostics, protection, and fail-safe operation modes. The SBC may include zero, one or two LIN 2.1 interfaces with LIN output pin switches. It includes up to four wake-up input pins that can also be configured as output drivers for flexibility. This device is powered by SMARTMOS technology.

This device implements multiple Low-power (LP) modes, with very low-current consumption. In addition, the device is part of a family concept where pin compatibility adds versatility to module design.

The 33903/4/5 also implements an innovative and advanced fail-safe state machine and concept solution.

Features

- Voltage regulator for MCU, 5.0 or 3.3 V, part number selectable, with possibility of usage external PNP to extend current capability and share power dissipation
- Voltage, current, and temperature protection
- Extremely low quiescent current in LP modes
- Fully-protected embedded 5.0 V regulator for the CAN driver
- Multiple undervoltage detections to address various MCU specifications and system operation modes (i.e. cranking)
- Auxiliary 5.0 or 3.3 V SPI configurable regulator, for additional ICs, with overcurrent detection and undervoltage protection
- MUX output pin for device internal analog signal monitoring and power supply monitoring
- Advanced SPI, MCU, ECU power supply, and critical pins diagnostics and monitoring.
- Multiple wake-up sources in LP modes: CAN or LIN bus, I/O transition, automatic timer, SPI message, and V_{DD} overcurrent detection.
- ISO11898-5 high-speed CAN interface compatibility for baud rates of 40 kb/s to 1.0 Mb/s
- Scalable product family of devices ranging from 0 to 2 LINs which are compatible to J2602-2 and LIN 2.1

33903/4/5

SYSTEM BASIS CHIP

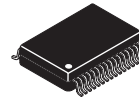

EK Suffix (Pb-free)
98ASA10556D/
98ASA00259D
32-PIN SOIC

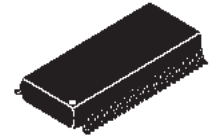

EK Suffix (Pb-free)
98ASA10506D
54-PIN SOIC

Applications

- Aircraft and marine systems
- Automotive and robotic systems
- Farm equipment
- Industrial actuator controls
- Lamp and inductive load controls
- DC motor control applications requiring diagnostics
- Applications where high-side switch control is required

Table of Contents

1. Simplified application diagrams	3
2. Orderable part	7
3. Internal block diagrams	9
4. Pin Connections	11
4.1. Pinout diagram	11
5. Electrical characteristics	16
5.1. Maximum ratings	16
5.2. Static electrical characteristics	18
5.3. Dynamic electrical characteristics	26
5.4. Timing diagrams	29
6. Functional description	32
6.1. Introduction	32
6.2. Functional pin description	32
7. Functional device operation	36
7.1. Mode and state description	36
7.2. LP modes	37
7.3. State diagram	39
7.4. Mode change	40
7.5. Watchdog operation	40
7.6. Functional block operation versus mode	43
7.7. Illustration of device mode transitions	44
7.8. Cyclic sense operation during LP modes	45
7.9. Cyclic INT operation during LP VDD on mode	47
7.10. Behavior at power up and power down	48
7.11. Fail-safe operation	51
8. CAN interface	55
8.1. CAN interface description	55
8.2. CAN bus fault diagnostic	58
9. LIN block	62
9.1. LIN interface description	62
9.2. LIN operational modes	63
10. Serial peripheral interface	64
10.1. High level overview	64
10.2. Detail operation	64
10.3. Detail of control bits and register mapping	68
10.4. Flags and device status	84
11. Typical applications	92
12. Packaging	100
12.1. SOIC 32 package dimensions	100
12.2. SOIC 54 package dimensions	106
13. Revision history	109

1 Simplified application diagrams

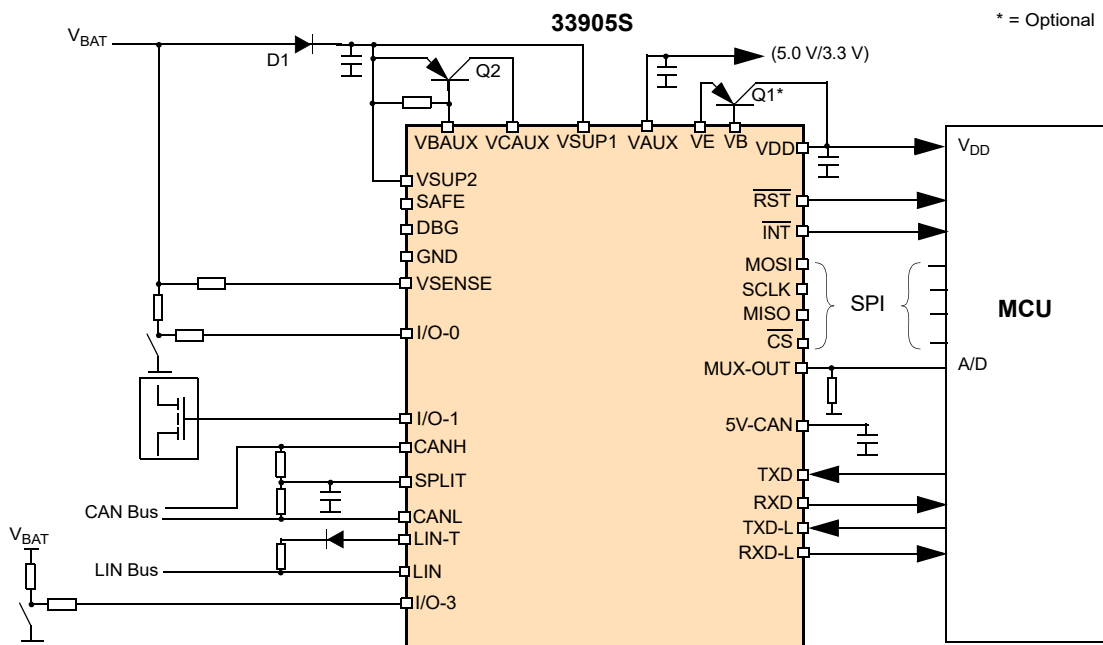
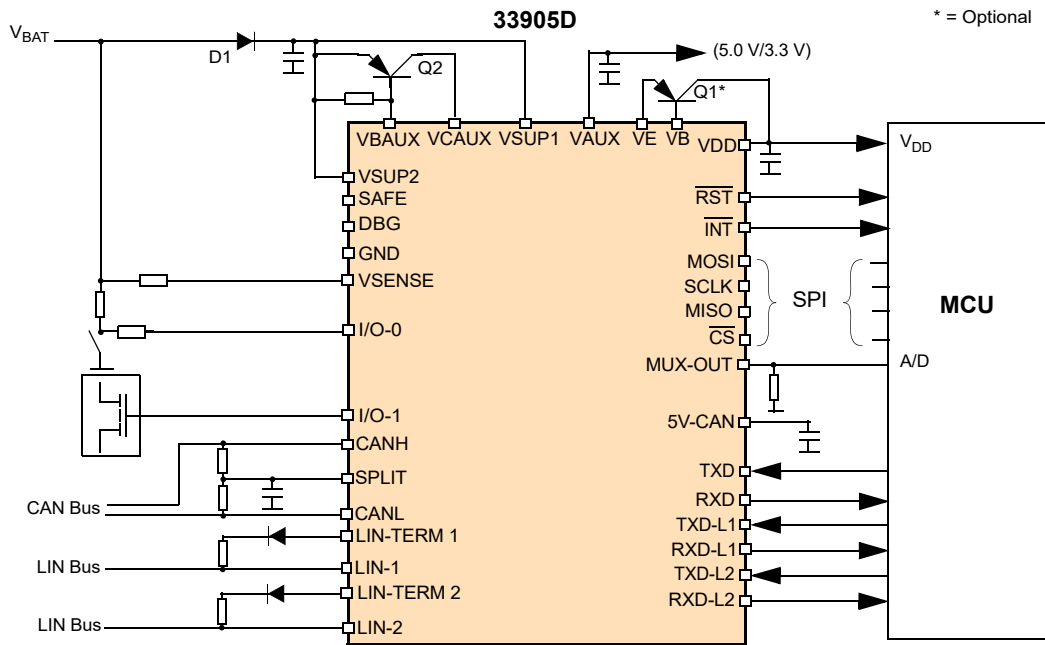

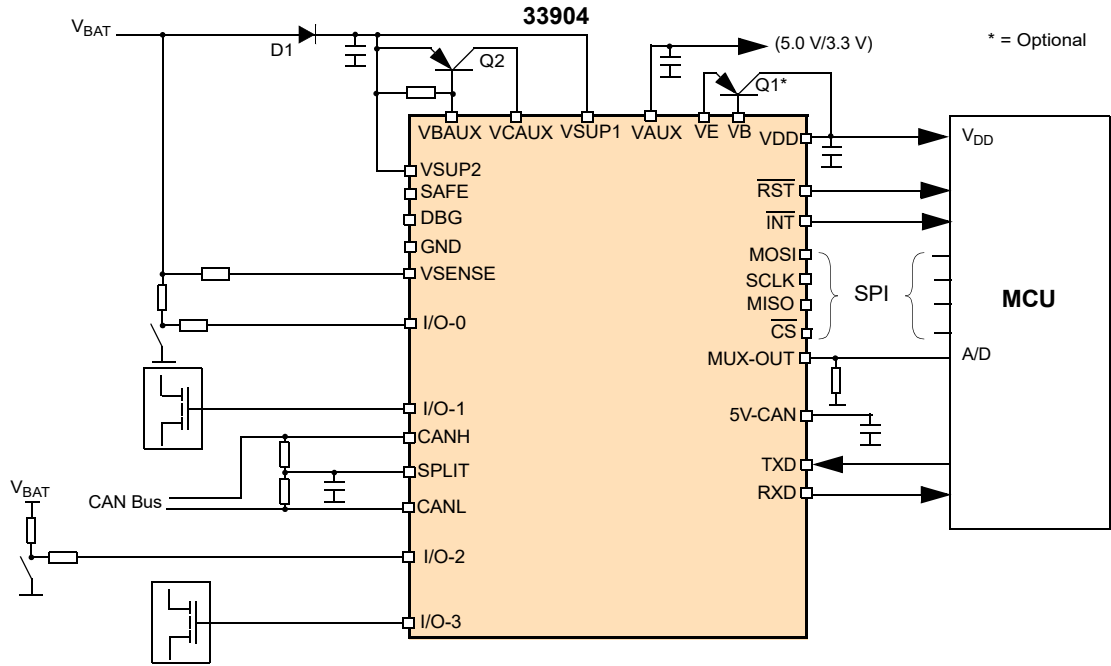

Figure 3. 33904 simplified application diagram

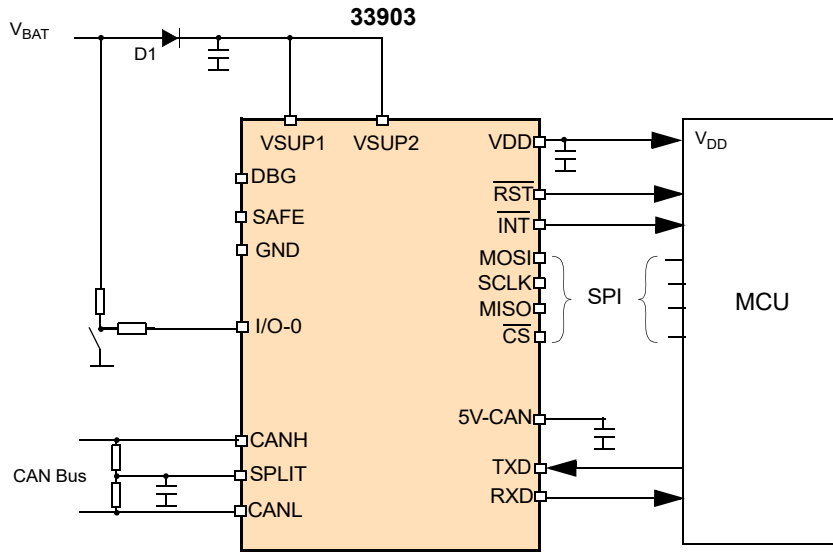

Figure 4. 33903 simplified application diagram

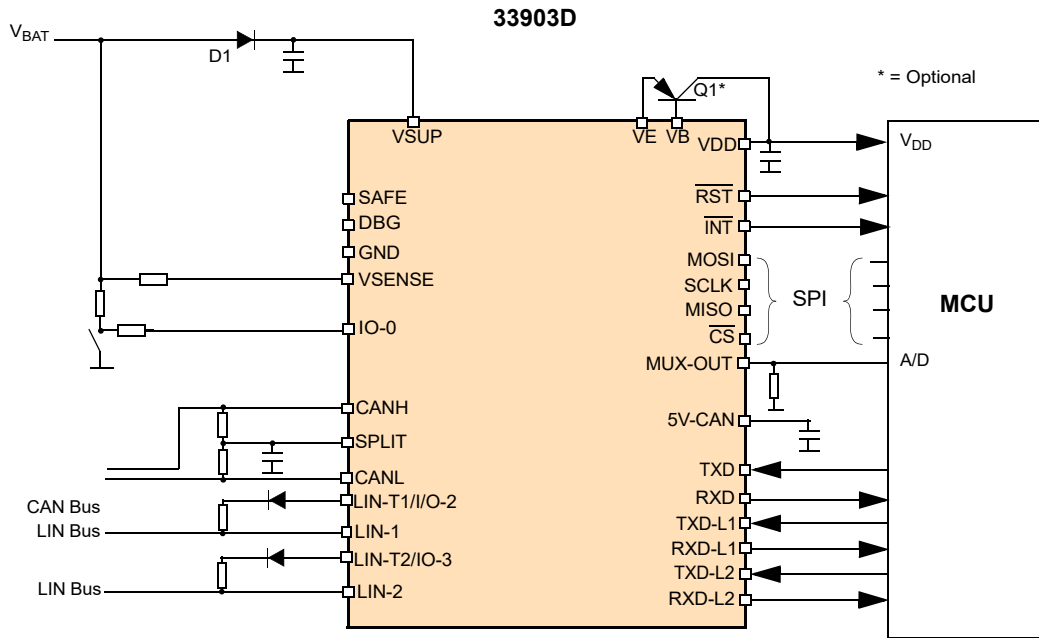

Figure 5. 33903D simplified application diagram

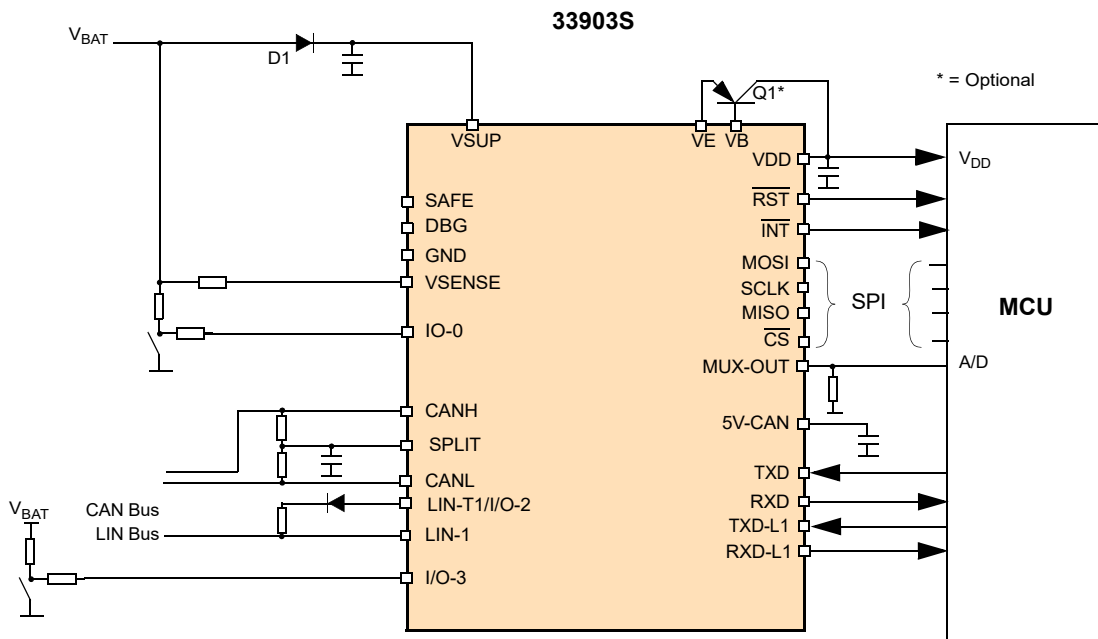

Figure 6. 33903S simplified application diagram

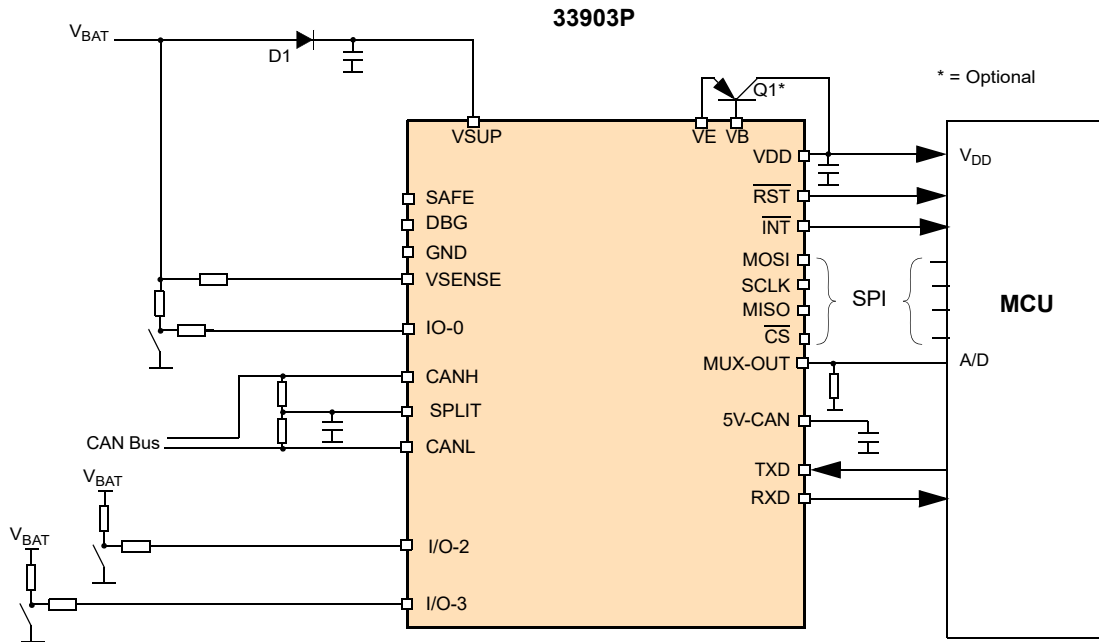

Figure 7. 33903P simplified application diagram

2 Orderable part

Table 1. MC33905 orderable part variations - (all devices rated at $T_A = -40\text{ °C TO }125\text{ °C}$)

NXP part number	Version	V _{DD} output voltage	LIN interface(s)	Wake-up input / LIN master termination	Package	V _{AUX}	V _{SENSE}	MUX
MC33905D (Dual LIN)								
MCZ33905DD3EK/R2	D	3.3 V	2	2 Wake-up + 2 LIN terms or 3 Wake-up + 1 LIN terms or 4 Wake-up + no LIN terms	SOIC 54-pin exposed pad SOT1747-3	Yes	Yes	Yes
MCZ33905DD5EK/R2	D	5.0V						
MC33905S (Single LIN)								
MCZ33905DS3EK/R2	D	3.3 V	1	3 Wake-up + 1 LIN terms or 4 Wake-up + no LIN terms	SOIC 32-pin exposed pad SOT1746-3	Yes	Yes	Yes
MCZ33905DS5EK/R2	D	5.0 V						

Table 2. MC33904 orderable part variations - (all devices rated at $T_A = -40\text{ °C TO }125\text{ °C}$)

NXP part number	Version	V _{DD} output voltage	LIN interface(s)	Wake-up input / LIN master termination	Package	V _{AUX}	V _{SENSE}	MUX
MC33904								
MCZ33904D3EK/R2	D	3.3 V	0	4 Wake-up	SOIC 32 pin exposed pad SOT1746-3	Yes	Yes	Yes
MCZ33904D5EK/R2	D	5.0 V						

Table 3. MC33903 orderable part variations - (all devices rated at $T_A = -40\text{ °C TO }125\text{ °C}$)

NXP part number	Version (1)	V _{DD} output voltage	LIN interface(s)	Wake-up input / LIN master termination	Package	V _{AUX}	V _{SENSE}	MUX
MC33903								
MCZ33903D3EK/R2	D	3.3 V ⁽²⁾	0	1 Wake-up	SOIC 32 pin exposed pad SOT1746-3	No	No	No
MCZ33903D5EK/R2	D	5.0 V ⁽²⁾						
MC33903D (Dual LIN)								
MCZ33903DD3EK/R2	D	3.3 V	2	1 Wake-up + 2 LIN terms or 2 Wake-up + 1 LIN terms or 3 Wake-up + no LIN terms	SOIC 32 pin exposed pad SOT1762-2	No	Yes	Yes
MCZ33903DD5EK/R2	D	5.0 V						
MC33903S (Single LIN)								
MCZ33903DS3EK/R2	D	3.3 V	1	2 Wake-up + 1 LIN terms or 3 Wake-up + no LIN terms	SOIC 32 pin exposed pad SOT1762-2	No	Yes	Yes
MCZ33903DS5EK/R2	D	5.0 V						
MC33903P								
MCZ33903DP5EK/R2	D	5.0 V	0	3 Wake-up	SOIC 32 pin exposed pad SOT1762-2	No	Yes	Yes
MCZ33903DP3EK/R2	D	3.3 V						

Notes

- Design changes in the 'B' version resolved V_{SUP} slow ramp up issues, enhanced device current consumption and improved oscillator stability. 'B' version has an errata linked to the SPI operation. Design changes in the 'C' version resolve the SPI deviation of all prior versions, and does not have the RxD short to ground detection feature. The 'C' versions are no longer recommended for new designs. The 'D' versions are recommended for new designs, and include quality improvements, and have no electrical parameters specification changes.
- V_{DD} does not allow usage of an external PNP on the 33903.

3 Internal block diagrams

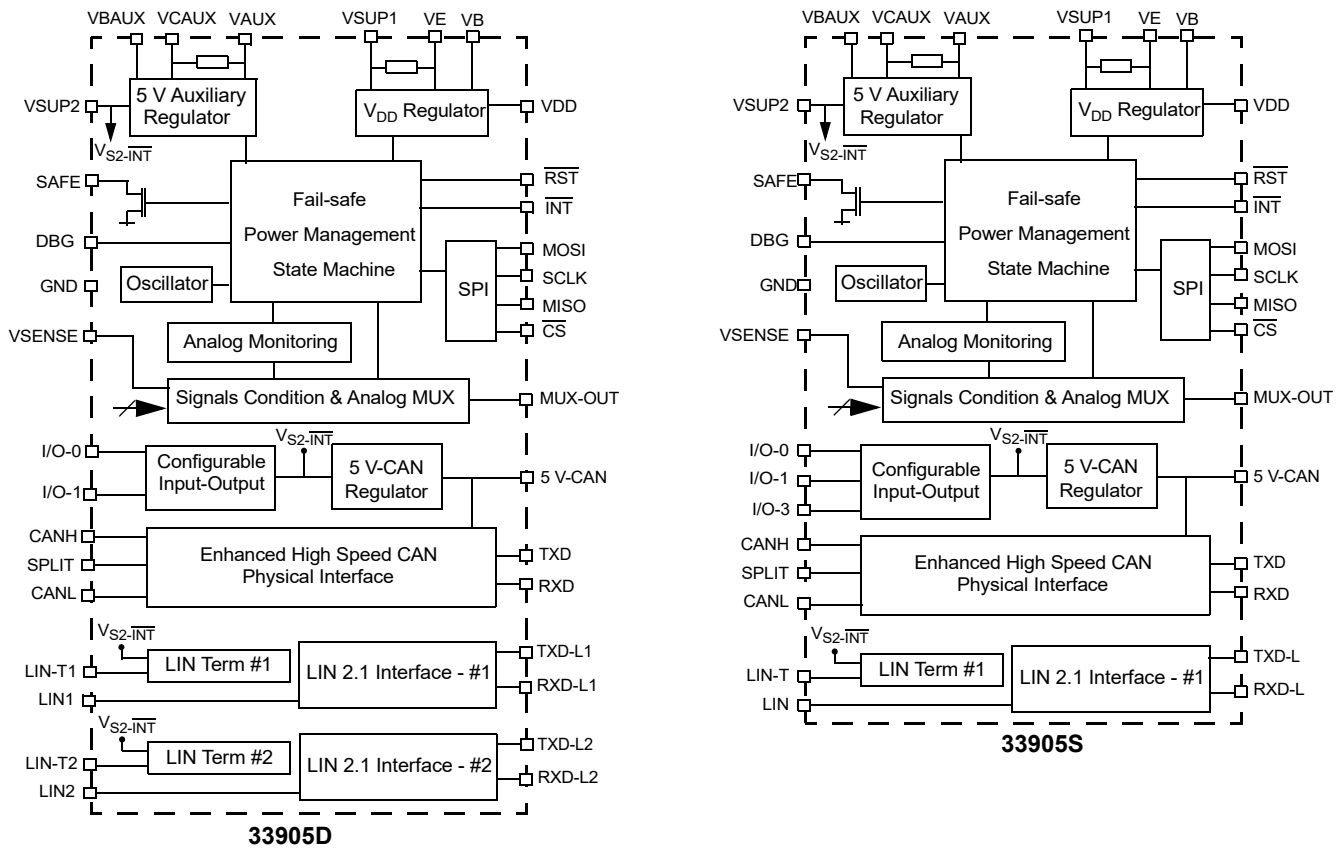

Figure 8. 33905 internal block diagram

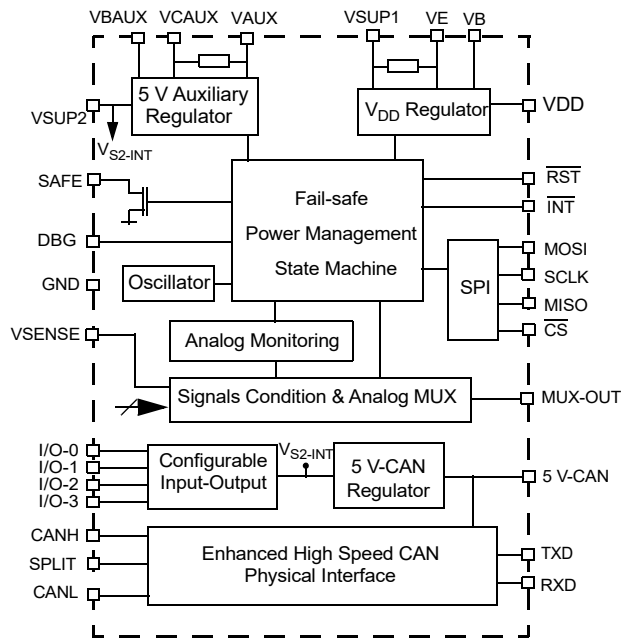

Figure 9. 33904 internal block diagram

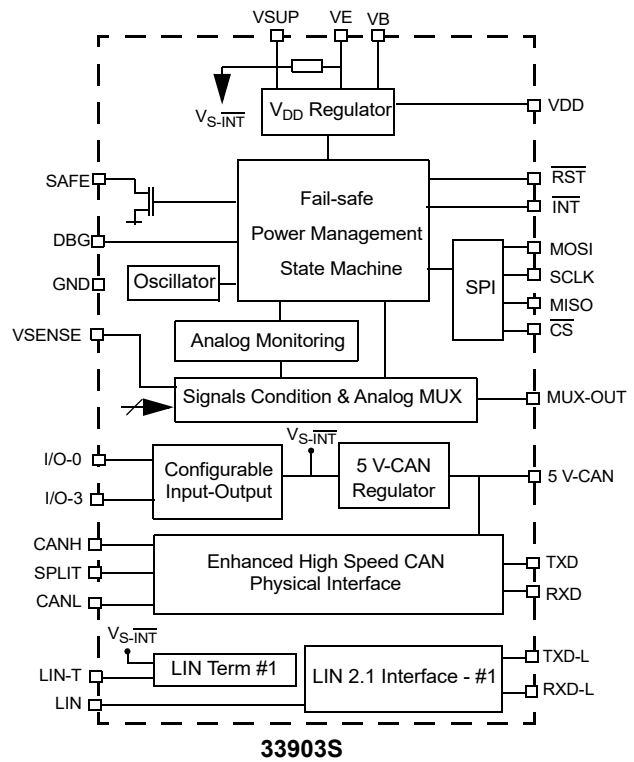
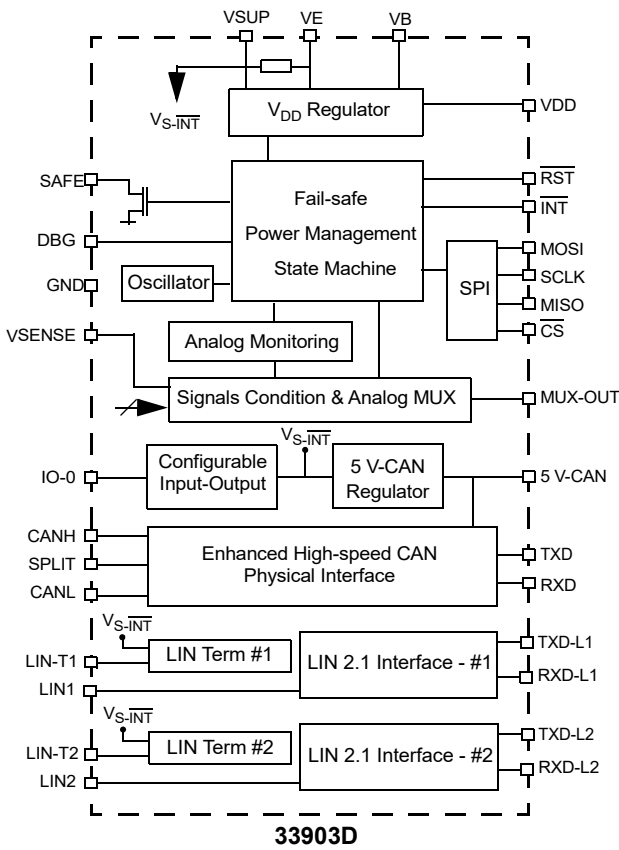
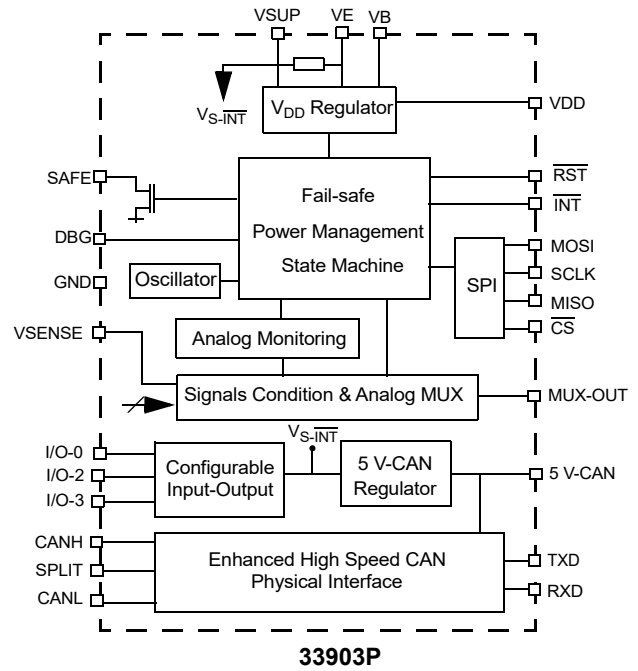
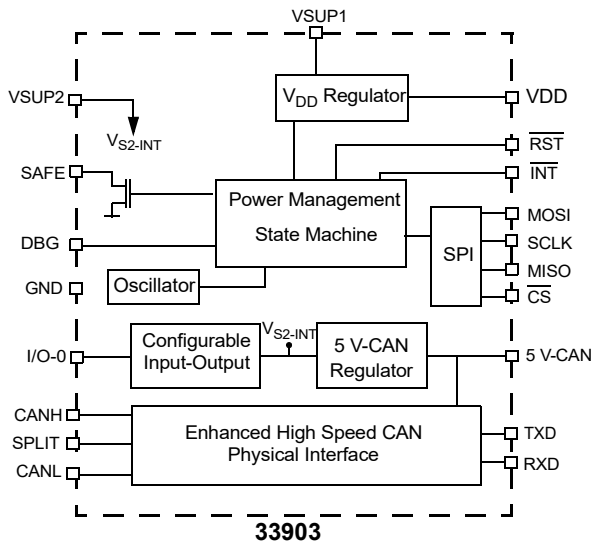
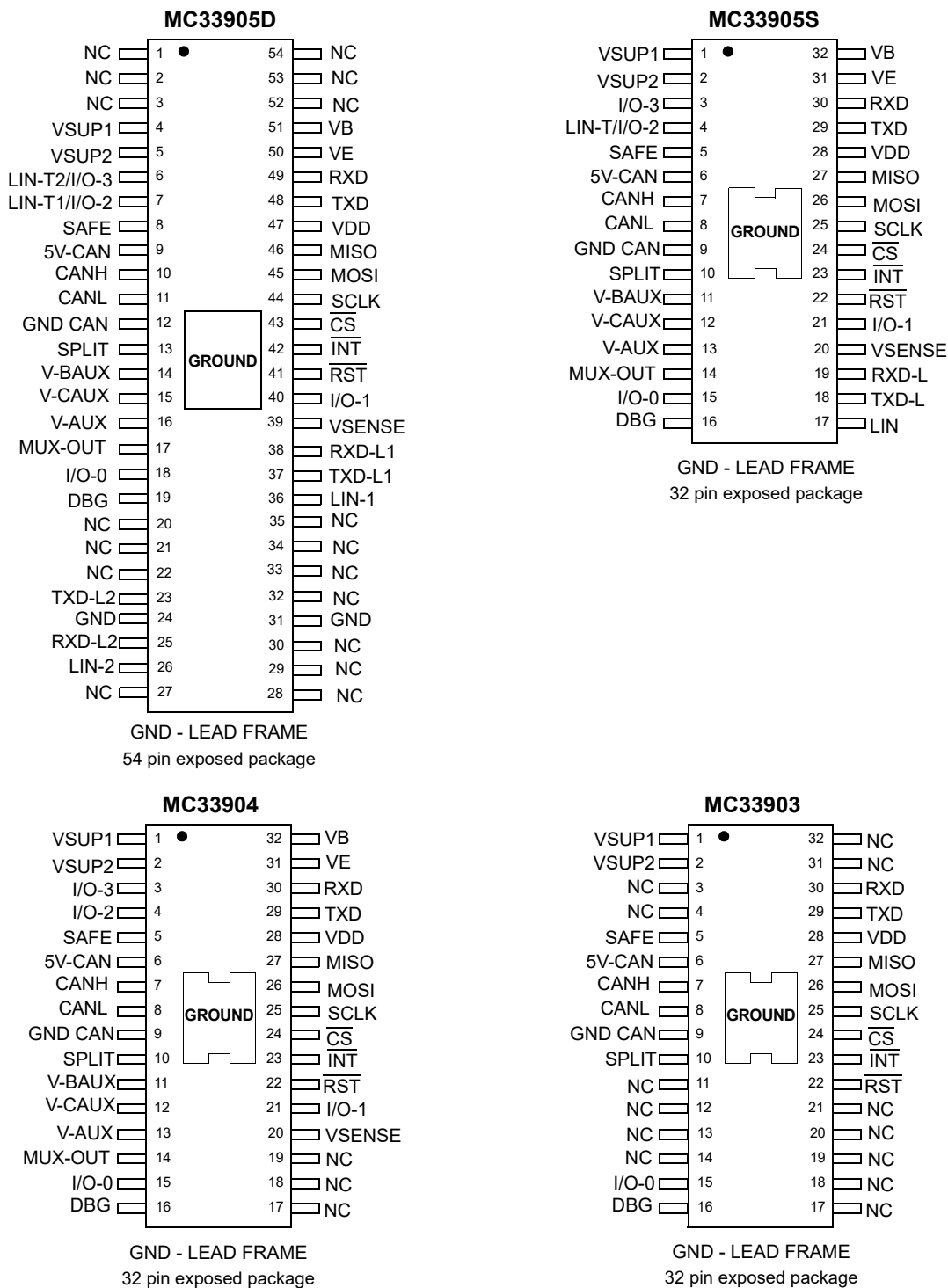

Figure 10. 33903 internal block diagram

4 Pin Connections

4.1 Pinout diagram



Note: MC33905D, MC33905S, MC33904 and MC33903 are footprint compatible,

Figure 11. 33905D, MC33905S, MC33904 and MC33903 pin connections

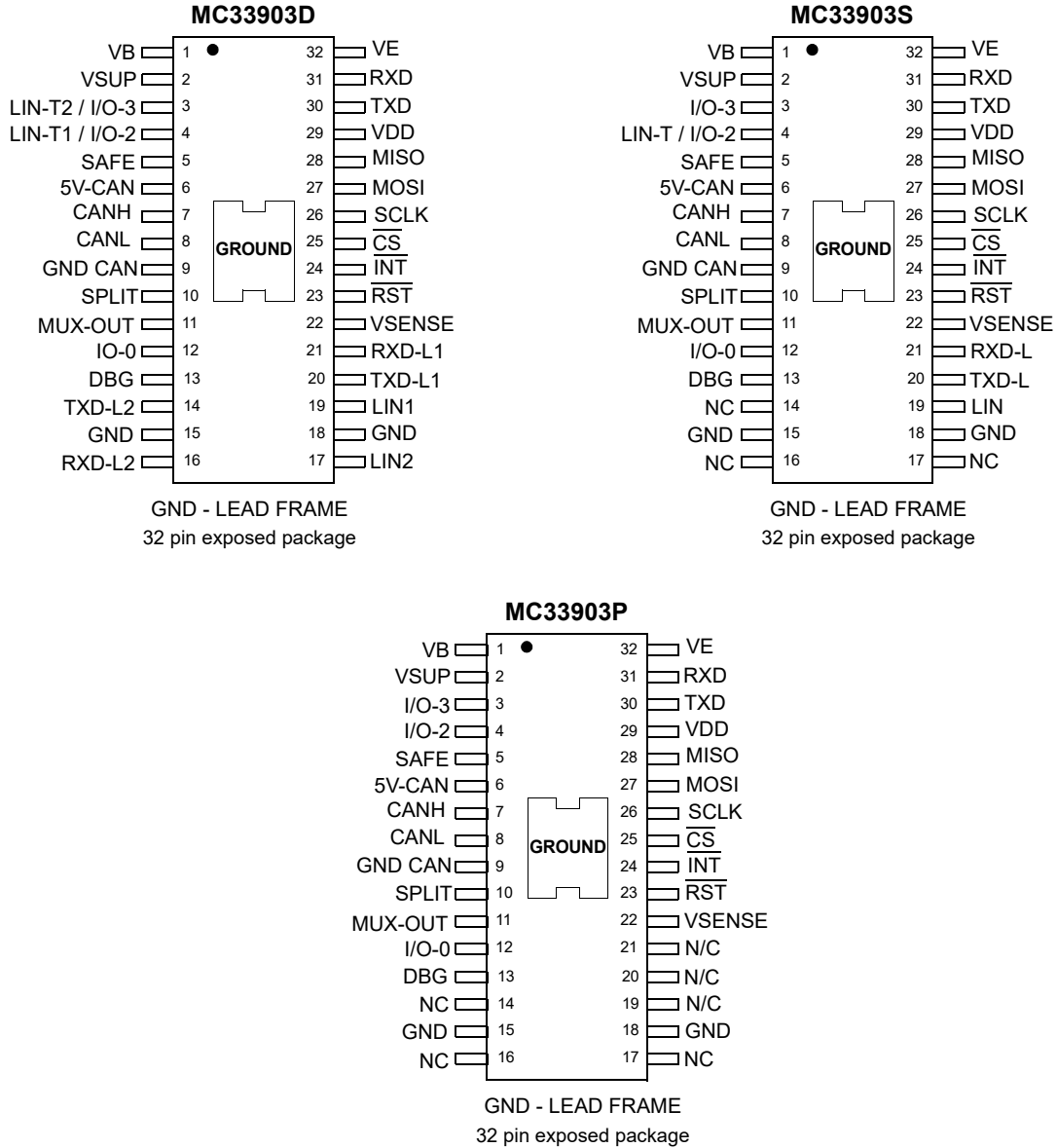

Note: MC33903D, MC33903S, and MC33903P are footprint compatible.

Figure 12. 33905D, MC33905S, MC33904 and MC33903 pin connections

4.2 Pin definitions

A functional description of each pin can be found in the [Functional pin description](#) section beginning on [page 32](#).

Table 4. 33903/4/5 pin definitions

54 Pin 33905D	32 Pin 33905S	32 Pin 33904	32 Pin 33903	32 Pin 33903D	32 Pin 33903S	32 Pin 33903P	Pin Name	Pin Function	Formal Name	Definition
1-3, 20-22, 27-30, 32-35, 52-54	N/A	17, 18, 19	3-4, 11-14, 17-21, 31, 32	N/A	N/A	N/A	N/C	No Connect	-	Connect to GND.
N/A	N/A	N/A	N/A	N/A	14, 16, 17	14, 16, 17, 19-21	N/C	No Connect		Do NOT connect the N/C pins to GND. Leave these pins Open.
4	1	1	1	2	2	2	VSUP/1	Power	Battery Voltage Supply 1	Supply input for the device internal supplies, power on reset circuitry and the V_{DD} regulator. VSUP and VSUP1 supplies are internally connected on part number 33903D, 33903S, and 33903P.
5	2	2	2	N/A	N/A	N/A	VSUP2	Power	Battery Voltage Supply 2	Supply input for 5 V-CAN regulator, V_{AUX} regulator, I/O and LIN pins. VSUP1 and VSUP2 supplies are internally connected on part number 33903D, 33903S, and 33903P.
6	3	3	N/A	3	3	3	LIN-T2 or I/O-3	Output or Input/Output	LIN Termination 2 or Input/Output 3	33903D and 33905D - Output pin for the LIN2 master node termination resistor. or 33903P, 33903S, 33903D, 33904, 33905S and 33905D - Configurable pin as an input or HS output, for connection to external circuitry (switched or small load). The input can be used as a programmable Wake-up input in (LP) mode. When used as a HS, no overtemperature protection is implemented. A basic short to GND protection function, based on switch drain-source overvoltage detection, is available.
7	4	4	N/A	4	4	4	LIN-T1 or LIN-T or I/O-2	Output or Input/Output	LIN Termination 1 or Input/Output 2	33905D - Output pin for the LIN1 master node termination resistor. or 33903P, 33903S, 33903D, 33904, 33905S and 33905D - Configurable pin as an input or HS output, for connection to external circuitry (switched or small load). The input can be used as a programmable Wake-up input in (LP) mode. When used as a HS, no overtemperature protection is implemented. A basic short to GND protection function, based on switch drain-source overvoltage detection, is available.
8	5	5	5	5	5	5	SAFE	Output	Safe Output (Active LOW)	Output of the safe circuitry. The pin is asserted LOW if a fault event occurs (e.g.: software watchdog is not triggered, V_{DD} low, issue on the RST pin, etc.). Open drain structure.
9	6	6	6	6	6	6	5 V-CAN	Output	5V-CAN	Output voltage for the embedded CAN interface. A capacitor must be connected to this pin.
10	7	7	7	7	7	7	CANH	Output	CAN High	CAN high output.
11	8	8	8	8	8	8	CANL	Output	CAN Low	CAN low output.
12	9	9	9	9	9	9	GND-CAN	Ground	GND-CAN	Power GND of the embedded CAN interface
13	10	10	10	10	10	10	SPLIT	Output	SPLIT Output	Output pin for connection to the middle point of the split CAN termination

Table 4. 33903/4/5 pin definitions (continued)

54 Pin 33905D	32 Pin 33905S	32 Pin 33904	32 Pin 33903	32 Pin 33903D	32 Pin 33903S	32 Pin 33903P	Pin Name	Pin Function	Formal Name	Definition
14	11	11	N/A	N/A	N/A	N/A	VBAUX	Output	VB Auxiliary	Output pin for external path PNP transistor base
15	12	12	N/A	N/A	N/A	N/A	VCAUX	Output	VCOLLECT OR Auxiliary	Output pin for external path PNP transistor collector
16	13	13	N/A	N/A	N/A	N/A	VAUX	Output	VOUT Auxiliary	Output pin for the auxiliary voltage.
17	14	14	N/A	11	11	11	MUX-OUT	Output	Multiplex Output	Multiplexed output to be connected to an MCU A/D input. Selection of the analog parameter available at MUX-OUT is done via the SPI. A switchable internal pull-down resistor is integrated for V _{DD} current sense measurements.
18	15	15	15	12	12	12	I/O-0	Input/ Output	Input/Output 0	Configurable pin as an input or output, for connection to external circuitry (switched or small load). The voltage level can be read by the SPI and via the MUX output pin. The input can be used as a programmable Wake-up input in LP mode. In LP, when used as an output, the High-side (HS) or Low-side (LS) can be activated for a cyclic sense function.
19	16	16	16	13	13	13	DBG	Input	Debug	Input to activate the Debug mode. In Debug mode, no watchdog refresh is necessary. Outside of Debug mode, connection of a resistor between DBG and GND allows the selection of Safe mode functionality.
23	N/A	N/A	N/A	14	N/A	N/A	TXD-L2	Input	LIN Transmit Data 2	LIN bus transmit data input. Includes an internal pull-up resistor to VDD.
24,31	N/A	N/A	N/A	15, 18	15, 18	15, 18	GND	Ground	Ground	Ground of the IC.
25	N/A	N/A	N/A	16	N/A	N/A	RXD-L2	Output	LIN Receive Data	LIN bus receive data output.
26	N/A	N/A	N/A	17	N/A	N/A	LIN2	Input/ Output	LIN bus	LIN bus input output connected to the LIN bus.
36	17	N/A	N/A	19	19	N/A	33903D/5D LIN-1 33903S/5S LIN	Input/ Output	LIN bus	LIN bus input output connected to the LIN bus.
37	18	N/A	N/A	20	20	N/A	33903D/5D TXD-L11 33903S/5S TXD-L	Input	LIN Transmit Data	LIN bus transmit data input. Includes an internal pull-up resistor to VDD.
38	19	N/A	N/A	21	21	N/A	33903D/5D RXD-L1 33903S/5S RXD-L	Output	LIN Receive Data	LIN bus receive data output.
39	20	20	N/A	22	22	22	VSENSE	Input	Sense input	Direct battery voltage input sense. A serial resistor is required to limit the input current during high voltage transients.
40	21	21	N/A	N/A	N/A	N/A	I/O-1	Input/ Output	Input Output 1	Configurable pin as an input or output, for connection to external circuitry (switched or small load). The voltage level can be read by the SPI and the MUX output pin. The input can be used as a programmable Wake-up input in (LP) mode. It can be used in association with I/O-0 for a cyclic sense function in (LP) mode.

Table 4. 33903/4/5 pin definitions (continued)

54 Pin 33905D	32 Pin 33905S	32 Pin 33904	32 Pin 33903	32 Pin 33903D	32 Pin 33903S	32 Pin 33903P	Pin Name	Pin Function	Formal Name	Definition
41	22	22	22	23	23	23	$\overline{\text{RST}}$	Output	Reset Output (Active LOW)	This is the device reset output whose main function is to reset the MCU. This pin has an internal pull-up to VDD. The reset input voltage is also monitored in order to detect external reset and safe conditions.
42	23	23	23	24	24	24	$\overline{\text{INT}}$	Output	Interrupt Output (Active LOW)	This output is asserted low when an enabled interrupt condition occurs. This pin is an open drain structure with an internal pull up resistor to VDD.
43	24	24	24	25	25	25	$\overline{\text{CS}}$	Input	Chip Select (Active LOW)	Chip select pin for the SPI. When the $\overline{\text{CS}}$ is low, the device is selected. In (LP) mode with V _{DD} ON, a transition on CS is a Wake-up condition
44	25	25	25	26	26	26	SCLK	Input	Serial Data Clock	Clock input for the Serial Peripheral Interface (SPI) of the device
45	26	26	26	27	27	27	MOSI	Input	Master Out/ Slave In	SPI data received by the device
46	27	27	27	28	28	28	MISO	Output	Master In/ Slave Out	SPI data sent to the MCU. When the $\overline{\text{CS}}$ is high, MISO is high-impedance
47	28	28	28	29	29	29	VDD	Output	Voltage Digital Drain	5.0 or 3.3 V output pin of the main regulator for the Microcontroller supply.
48	29	29	29	30	30	30	TXD	Input	Transmit Data	CAN bus transmit data input. Internal pull-up to VDD
49	30	30	30	31	31	31	RXD	Output	Receive Data	CAN bus receive data output
50	31	31	N/A	32	32	32	VE		Voltage Emitter	Connection to the external PNP path transistor. This is an intermediate current supply source for the V _{DD} regulator
51	32	32	N/A	1	1	1	VB	Output	Voltage Base	Base output pin for connection to the external PNP pass transistor
EX PAD	EX PAD	EX PAD	EX PAD	EX PAD	EX PAD	EX PAD	GND	Ground	Ground	Ground

5 Electrical characteristics

5.1 Maximum ratings

Table 5. Maximum ratings

All voltages are referenced to ground unless otherwise noted. Exceeding these ratings may cause a malfunction or permanent damage to the device.

Symbol	Ratings	Value	Unit	Notes
Electrical ratings⁽³⁾				
$V_{SUP1/2}$ $V_{SUP1/2TR}$	Supply Voltage at VSUP/1 and VSUP2 Normal Operation (DC) Transient Conditions (Load Dump)	-0.3 to 28 -0.3 to 40	V	
V_{BUSLIN} $V_{BUSLINTR}$	DC voltage on LIN/1 and LIN2 Normal Operation (DC) Transient Conditions (Load Dump)	-28 to 28 -28 to 40	V	
V_{BUS} V_{BUSTR}	DC voltage on CANL, CANH, SPLIT Normal Operation (DC) Transient Conditions (Load Dump)	-28 to 28 -32 to 40	V	
V_{SAFE} V_{SAFETR}	DC Voltage at SAFE Normal Operation (DC) Transient Conditions (Load Dump)	-0.3 to 28 -0.3 to 40	V	
$V_{I/O}$ $V_{I/OTR}$	DC Voltage at I/O-0, I/O-1, I/O-2, I/O-3 (LIN-T Pins) Normal Operation (DC) Transient Conditions (Load Dump)	-0.3 to 28 -0.3 to 40	V	
V_{DIGLIN}	DC voltage on TXD-L, TXD-L1 TXD-L2, RXD-L, RXD-L1, RXD-L2	-0.3 to $V_{DD} + 0.3$	V	
V_{DIG}	DC voltage on TXD, RXD	-0.3 to $V_{DD} + 0.3$	V	(5)
V_{INT}	DC Voltage at \overline{INT}	-0.3 to 10	V	
V_{RST}	DC Voltage at \overline{RST}	-0.3 to $V_{DD} + 0.3$	V	
V_{RST}	DC Voltage at MOSI, MSIO, SCLK and \overline{CS}	-0.3 to $V_{DD} + 0.3$	V	
V_{MUX}	DC Voltage at MUX-OUT	-0.3 to $V_{DD} + 0.3$	V	
V_{DBG}	DC Voltage at DBG	-0.3 to 10	V	
ILH	Continuous current on CANH and CANL	200	mA	
V_{REG}	DC voltage at VDD, 5V-CAN, VAUX, VCAUX	-0.3 to 5.5	V	
V_{REG}	DC voltage at VBASE and VBAUX	-0.3 to 40	V	(4)
VE	DC voltage at VE	-0.3 to 40	V	(5)
V_{SENSE}	DC voltage at VSENSE	-28 to 40	V	

Notes

- The voltage on non-VSUP pins should never exceed the V_{SUP} voltage at any time or permanent damage to the device may occur.
- If the voltage delta between VSUP/1/2 and VBASE is greater than 6.0 V, the external V_{DD} ballast current sharing functionality may be damaged.
- Potential Electrical Over Stress (EOS) damage may occur if RXD is in contact with VE while the device is ON.

Table 5. Maximum ratings (continued)

All voltages are referenced to ground unless otherwise noted. Exceeding these ratings may cause a malfunction or permanent damage to the device.

Symbol	Ratings	Value	Unit	Notes
V_{ESD1-1} V_{ESD1-2}	ESD Capability AECQ100 ⁽⁶⁾ Human Body Model - JESD22/A114 ($C_{ZAP} = 100 \text{ pF}$, $R_{ZAP} = 1500 \Omega$) CANH and CANL. LIN1 and LIN2, Pins versus all GND pins all other Pins including CANH and CANL	± 8000 ± 2000	V	
V_{ESD2-1} V_{ESD2-2}	Charge Device Model - JESD22/C101 ($C_{ZAP} = 4.0 \text{ pF}$) Corner Pins (Pins 1, 16, 17, and 32) All other Pins (Pins 2-15, 18-31)	± 750 ± 500		
V_{ESD3-1} V_{ESD3-2} V_{ESD3-3}	Tested per IEC 61000-4-2 ($C_{ZAP} = 150 \text{ pF}$, $R_{ZAP} = 330 \Omega$) Device unpowered, CANH and CANL pin without capacitor, versus GND Device unpowered, LIN, LIN1 and LIN2 pin, versus GND Device unpowered, VS1/VS2 (100 nF to GND), versus GND	± 15000 ± 15000 ± 15000		
V_{ESD4-1} V_{ESD4-2} V_{ESD4-3}	Tested per specific OEM EMC requirements for CAN and LIN with additional capacitor on VSUP/1/2 pins (See Typical applications on page 92) CANH, CANL without bus filter LIN, LIN1 and LIN2 with and without bus filter I/O with external components (22 k - 10 nF)	± 9000 ± 12000 ± 7000		

Thermal ratings

T_J	Junction temperature	150	$^{\circ}\text{C}$	
T_A	Ambient temperature	-40 to 125	$^{\circ}\text{C}$	
T_{ST}	Storage temperature	-50 to 150	$^{\circ}\text{C}$	

Thermal resistance

$R_{\theta JA}$	Thermal resistance junction to ambient	50	$^{\circ}\text{C}/\text{W}$	(9)
T_{PPRT}	Peak package reflow temperature during reflow	Note 8	$^{\circ}\text{C}$	(7), (8)

Notes

- ESD testing is performed in accordance with the Human Body Model (HBM) ($C_{ZAP} = 100 \text{ pF}$, $R_{ZAP} = 1500 \Omega$), the Charge Device Model (CDM), and Robotic ($C_{ZAP} = 4.0 \text{ pF}$).
- Pin soldering temperature limit is for 10 seconds maximum duration. Not designed for immersion soldering. Exceeding these limits may cause malfunction or permanent damage to the device.
- NXP's Package Reflow capability meets Pb-free requirements for JEDEC standard J-STD-020C. For Peak Package Reflow Temperature and Moisture Sensitivity Levels (MSL), go to www.nxp.com, search by part number (remove prefixes/suffixes) and enter the core ID to view all orderable parts, and review parametrics.
- This parameter was measured according to [Figure 13](#):

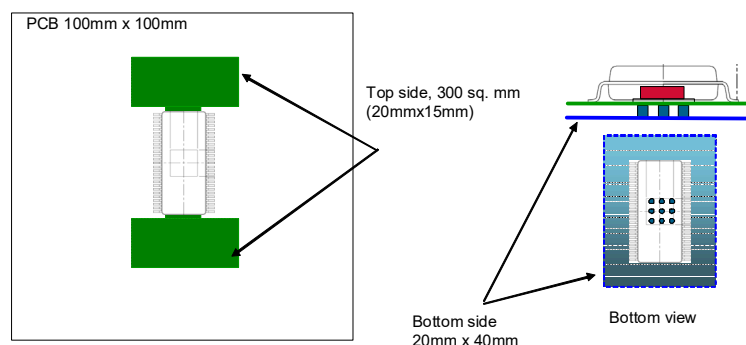
**Figure 13. PCB with top and bottom layer dissipation area (dual layer)**

5.2 Static electrical characteristics

Table 6. Static electrical characteristics

Characteristics noted under conditions $5.5\text{ V} \leq V_{\text{SUP}} \leq 28\text{ V}$, $-40\text{ }^\circ\text{C} \leq T_{\text{A}} \leq 125\text{ }^\circ\text{C}$, unless otherwise noted. Typical values noted reflect the approximate parameter means at $T_{\text{A}} = 25\text{ }^\circ\text{C}$ under nominal conditions, unless otherwise noted.

Symbol	Characteristic	Min.	Typ.	Max.	Unit	Notes
Power input						
$V_{\text{SUP1}}/V_{\text{SUP2}}$	Nominal DC Voltage Range	5.5	-	28	V	(10)
$V_{\text{SUP1}}/V_{\text{SUP2}}$	Extended DC Low Voltage Range	4.0	-	5.5	V	(11)
$V_{\text{S1_LOW}}$	Undervoltage Detector Thresholds, at the VSUP/1 pin, Low threshold (VSUP/1 ramp down) High threshold (VSUP/1 ramp up) Hysteresis Note: function not active in LP mode	5.5 - 0.22	6.0 - 0.35	6.5 6.6 0.5	V	
$V_{\text{S2_LOW}}$	Undervoltage Detector Thresholds, at the VSUP2 pin: Low threshold (VSUP2 ramp down) High threshold (VSUP2 ramp up) Hysteresis Note: function not active in LP modes	5.5 - 0.22	6.0 - 0.35	6.5 6.6 0.5	V	
$V_{\text{S_HIGH}}$	V_{SUP} Overvoltage Detector Thresholds, at the VSUP/1 pin: Not active in LP modes	16.5	17	18.5	V	
BATFAIL	Battery loss detection threshold, at the VSUP/1 pin.	2.0	2.8	4.0	V	
$V_{\text{SUP-TH1}}$	VSUP/1 to turn V_{DD} ON, VSUP/1 rising	-	4.1	4.5	V	
$V_{\text{SUP-TH1HYST}}$	VSUP/1 to turn V_{DD} ON, hysteresis (Guaranteed by design)	150	180		mV	
I_{SUP1}	Supply current - from VSUP/1 - from VSUP2, (5V-CAN V_{AUX} , I/O OFF)	- -	2.0 0.05	4.0 0.85	mA	(12), (13)
$I_{\text{SUP1+2}}$	Supply current, $I_{\text{SUP1}} + I_{\text{SUP2}}$, Normal mode, V_{DD} ON - 5 V-CAN OFF, V_{AUX} OFF - 5 V-CAN ON, CAN interface in Sleep mode, V_{AUX} OFF - 5 V-CAN OFF, V_{aux} ON - 5 V-CAN ON, CAN interface in TXD/RXD mode, V_{AUX} OFF, I/O-x disabled	- - - -	2.8 - - -	4.5 5.0 5.5 8.0	mA	
$I_{\text{LPM_OFF}}$	LP mode V_{DD} OFF. Wake-up from CAN, I/O-x inputs $V_{\text{SUP}} \leq 18\text{ V}$, -40 to $25\text{ }^\circ\text{C}$ $V_{\text{SUP}} \leq 18\text{ V}$, $125\text{ }^\circ\text{C}$	- -	15 -	35 50	μA	
$I_{\text{LPM_ON}}$	LP mode V_{DD} ON (5.0 V) with V_{DD} undervoltage and V_{DD} overcurrent monitoring, Wake-up from CAN, I/O-x inputs $V_{\text{SUP}} \leq 18\text{ V}$, -40 to $25\text{ }^\circ\text{C}$, $I_{\text{DD}} = 1.0\text{ }\mu\text{A}$ $V_{\text{SUP}} \leq 18\text{ V}$, -40 to $25\text{ }^\circ\text{C}$, $I_{\text{DD}} = 100\text{ }\mu\text{A}$ $V_{\text{SUP}} \leq 18\text{ V}$, $125\text{ }^\circ\text{C}$, $I_{\text{DD}} = 100\text{ }\mu\text{A}$	- - -	20 40 -	- 65 85	μA	
I_{OSC}	LP mode, additional current for oscillator (used for: cyclic sense, forced Wake-up, and in LP V_{DD} ON mode cyclic interruption and watchdog) $V_{\text{SUP}} \leq 18\text{ V}$, -40 to $125\text{ }^\circ\text{C}$	-	5.0	9.0	μA	
V_{DBG}	Debug mode DBG voltage range	8.0	-	10	V	

Notes

- All parameters in spec (ex: V_{DD} regulator tolerance).
- Device functional, some parameters could be out of spec. V_{DD} is active, device is not in Reset mode if the lowest V_{DD} undervoltage reset threshold is selected (approx. 3.4 V). CAN and I/Os are not operational.
- In Run mode, CAN interface in Sleep mode, 5 V-CAN and V_{AUX} turned OFF. I_{OUT} at $V_{\text{DD}} < 50\text{ mA}$. Ballast: turned OFF or not connected.
- VSUP1 and VSUP2 supplies are internally connected on part numbers 33903D, 33903S, and 33903P. Therefore, I_{SUP1} and I_{SUP2} cannot be measured individually.

Table 6. Static electrical characteristics (continued)

Characteristics noted under conditions $5.5\text{ V} \leq V_{\text{SUP}} \leq 28\text{ V}$, $-40\text{ }^{\circ}\text{C} \leq T_{\text{A}} \leq 125\text{ }^{\circ}\text{C}$, unless otherwise noted. Typical values noted reflect the approximate parameter means at $T_{\text{A}} = 25\text{ }^{\circ}\text{C}$ under nominal conditions, unless otherwise noted.

Symbol	Characteristic	Min.	Typ.	Max.	Unit	Notes
V_{DD} Voltage regulator, VDD pin						
V _{OUT-5.0} V _{OUT-5.0-EMC} V _{OUT-3.3}	Output Voltage V _{DD} = 5.0 V, V _{SUP} 5.5 to 28 V, I _{OUT} 0 to 150 mA V _{DD} = 5.0 V, under EMC immunity test condition V _{DD} = 3.3 V, V _{SUP} 5.5 to 28 V, I _{OUT} 0 to 150 mA	4.9 4.9 3.234	5.0 5.0 3.3	5.1 5.15 3.4	V	(14)
V _{DROP}	Drop voltage without external PNP pass transistor V _{DD} = 5.0 V, I _{OUT} = 100 mA V _{DD} = 5.0 V, I _{OUT} = 150 mA	- -	330 -	450 500	mV	(15)
V _{DROP-B}	Drop voltage with external transistor I _{OUT} = 200 mA (I _{BALLAST} + I _{INTERNAL})	-	350	500	mV	(15)
V _{SUP1-3.3}	V _{SUP} /1 to maintain V _{DD} within V _{OUT-3.3} specified voltage range V _{DD} = 3.3 V, I _{OUT} = 150 mA V _{DD} = 3.3 V, I _{OUT} = 200 mA, external transistor implemented	4.0 4.0	- -	- -	V	
K	External ballast versus internal current ratio (I _{BALLAST} = K x Internal current)	1.5	2.0	2.5		
I _{LIM}	Output Current limitation, without external transistor	150	350	550	mA	
T _{PW}	Temperature pre-warning (Guaranteed by design)	-	140	-	°C	
T _{SD}	Thermal shutdown (Guaranteed by design)	160	-	-	°C	
C _{EXT}	Range of decoupling capacitor (Guaranteed by design)	4.7	-	100	μF	(16)
V _{DDL P}	LP mode V _{DD} ON, I _{OUT} ≤ 50 mA (time limited) V _{DD} = 5.0 V, 5.6 V ≤ V _{SUP} ≤ 28 V V _{DD} = 3.3 V, 5.6 V ≤ V _{SUP} ≤ 28 V	4.75 3.135	5.0 3.3	5.25 3.465	V	
L _{P-IOUTDC}	LP mode V _{DD} ON, dynamic output current capability (Limited duration. Ref. to device description).	-	-	50	mA	
L _{P-ITH}	LP V _{DD} ON mode: Overcurrent Wake-up threshold. Hysteresis	1.0 0.1	3.0 1.0	- -	mA	
L _{P-VDROP}	LP mode V _{DD} ON, drop voltage, at I _{OUT} = 30 mA (Limited duration. Ref. to device description)	-	200	400	mV	(15)
L _{P-MINVS}	LP mode V _{DD} ON, min V _{SUP} operation (Below this value, a V _{DD} undervoltage reset may occur)	5.5	-	-	V	
V _{DD_OFF}	V _{DD} when V _{SUP} < V _{SUP-TH1} , at I _{VDD} ≤ 10 μA (Guaranteed by design)	-	-	0.3	V	
V _{DD_START UP}	V _{DD} when V _{SUP} ≥ V _{SUP-TH1} , at I _{VDD} ≤ 40 mA (Guaranteed with parameter V _{SUP-TH1})	3.0	-	-	V	

Notes

- Guaranteed by design. During immunity tests, according to IEC62132-4, with RF injection applied to CAN or LIN pins. No filter components on CAN or LIN pins. When immunity tests are performed with a CAN filter component (common mode choke) or LIN filter component (capacitor), the V_{DD} specification is 5.0 V ±2%.
- For 3.3 V V_{DD} devices, the drop-out voltage test condition leads to a V_{SUP} below the min V_{SUP} threshold (4.0 V). As a result, the dropout voltage parameter cannot be specified.
- The regulator is stable without an external capacitor. Usage of an external capacitor is recommended for AC performance.

Table 6. Static electrical characteristics (continued)

Characteristics noted under conditions $5.5\text{ V} \leq V_{\text{SUP}} \leq 28\text{ V}$, $-40\text{ }^\circ\text{C} \leq T_{\text{A}} \leq 125\text{ }^\circ\text{C}$, unless otherwise noted. Typical values noted reflect the approximate parameter means at $T_{\text{A}} = 25\text{ }^\circ\text{C}$ under nominal conditions, unless otherwise noted.

Symbol	Characteristic	Min.	Typ.	Max.	Unit	Notes
Voltage regulator for CAN interface supply, 5.0 V-CAN pin						
5V-C OUT	Output voltage, $V_{\text{SUP}2} = 5.5$ to 40 V $I_{\text{OUT}} 0$ to 160 mA	4.75	5.0	5.25	V	
5V-C ILIM	Output Current limitation	160	280	-	mA	(17)
5V-C UV	Undervoltage threshold	4.1	4.5	4.7	V	
5V-CTS	Thermal shutdown (Guaranteed by design)	160	-	-	$^\circ\text{C}$	
C _{EXT-CAN}	External capacitance (Guaranteed by design)	1.0	-	100	μF	
V auxiliary output, 5.0 and 3.3 V selectable pin VB-Aux, VC-Aux, Vaux						
V _{AUX}	VAUX output voltage $V_{\text{AUX}} = 5.0\text{ V}$, $V_{\text{SUP}} = V_{\text{SUP}2} 5.5$ to 40 V , $I_{\text{OUT}} 0$ to 150 mA $V_{\text{AUX}} = 3.3\text{ V}$, $V_{\text{SUP}} = V_{\text{SUP}2} 5.5$ to 40 V , $I_{\text{OUT}} 0$ to 150 mA	4.75 3.135	5.0 3.3	5.25 3.465	V	
V _{AUX-UVTH}	VAUX undervoltage detector (VAUX configured to 5.0 V) Low Threshold Hysteresis VAUX undervoltage detector (VAUX configured to 3.3 V, default value)	4.2 0.06 2.75	4.5 - 3.0	4.70 0.12 3.135	V	
V _{AUX-ILIM}	VAUX overcurrent threshold detector V_{AUX} set to 3.3 V V_{AUX} set to 5.0 V	250 230	360 330	450 430	mA	
V _{AUX CAP}	External capacitance (Guaranteed by design)	2.2	-	100	μF	
Undervoltage reset and reset function, $\overline{\text{RST}}$ pin						
V _{RST-TH1}	V_{DD} undervoltage threshold down - 90% V_{DD} ($V_{\text{DD}} 5.0\text{ V}$) V_{DD} undervoltage threshold up - 90% V_{DD} ($V_{\text{DD}} 5.0\text{ V}$) V_{DD} undervoltage threshold down - 90% V_{DD} ($V_{\text{DD}} 3.3\text{ V}$) V_{DD} undervoltage threshold up - 90% V_{DD} ($V_{\text{DD}} 3.3\text{ V}$)	4.5 - 2.75 -	4.65 - 3.0 -	4.85 4.90 3.135 3.135	V	(18), (20) (18), (20)
V _{RST-TH2-5}	V_{DD} undervoltage reset threshold down - 70% V_{DD} ($V_{\text{DD}} 5.0\text{ V}$)	2.95	3.2	3.45	V	(19), (20)
V _{RST-HYST}	Hysteresis for threshold 90% V_{DD} , 5.0 V device for threshold 70% V_{DD} , 5.0 V device Hysteresis 3.3 V V_{DD} for threshold 90% V_{DD} , 3.3 V device	20 10 10	- - -	150 150 150	mV	
V _{RST-LP}	V_{DD} undervoltage reset threshold down - LP V_{DD} ON mode (Note: device change to Normal Request mode). $V_{\text{DD}} 5.0\text{ V}$ (Note: device change to Normal Request mode). $V_{\text{DD}} 3.3\text{ V}$	4.0 2.75	4.5 3.0	4.85 3.135	V	
V _{OL}	Reset V_{OL} @ 1.5 mA, $V_{\text{SUP}} 5.5$ to 28 V	-	300	500	mV	
I _{RESET LOW}	Current limitation, Reset activated, $V_{\text{RESET}} = 0.9 \times V_{\text{DD}}$	2.5	7.0	10	mA	
R _{PULL-UP}	Pull-up resistor (to VDD pin)	8.0	11	15	k Ω	

Notes

17. Current limitation will be reported by setting a flag.
18. Generate a Reset or an $\overline{\text{INT}}$. SPI programmable
19. Generate a Reset
20. In Non-LP modes

Table 6. Static electrical characteristics (continued)

Characteristics noted under conditions $5.5\text{ V} \leq V_{\text{SUP}} \leq 28\text{ V}$, $-40\text{ }^{\circ}\text{C} \leq T_{\text{A}} \leq 125\text{ }^{\circ}\text{C}$, unless otherwise noted. Typical values noted reflect the approximate parameter means at $T_{\text{A}} = 25\text{ }^{\circ}\text{C}$ under nominal conditions, unless otherwise noted.

Symbol	Characteristic	Min.	Typ.	Max.	Unit	Notes
Undervoltage reset and reset function, RST PIN (continued)						
$V_{\text{SUP-RSTL}}$	V_{SUP} to guaranteed reset low level	2.5	-	-	V	(21)
$V_{\text{RST-VTH}}$	Reset input threshold					
	Low threshold, $V_{\text{DD}} = 5.0\text{ V}$	1.5	-	-		
	High threshold, $V_{\text{DD}} = 5.0\text{ V}$	-	-	3.5	V	
	Low threshold, $V_{\text{DD}} = 3.3\text{ V}$	0.99	-	-		
	High threshold, $V_{\text{DD}} = 3.3\text{ V}$	-	-	2.31		
V_{HYST}	Reset input hysteresis	0.5	1.0	1.5	V	
I/O pins when function selected is output						
$V_{\text{I/O-0 HSDRP}}$	I/O-0 HS switch drop @ $I = -12\text{ mA}$, $V_{\text{SUP}} = 10.5\text{ V}$	-	0.5	1.4	V	
$V_{\text{I/O-2-3 HSDRP}}$	I/O-2 and I/O-3 HS switch drop @ $I = -20\text{ mA}$, $V_{\text{SUP}} = 10.5\text{ V}$	-	0.5	1.4	V	
$V_{\text{I/O-1 HSDRP}}$	I/O-1, HS switch drop @ $I = -400\text{ }\mu\text{A}$, $V_{\text{SUP}} = 10.5\text{ V}$	-	0.4	1.4	V	
$V_{\text{I/O-01 LSDRP}}$	I/O-0, I/O-1 LS switch drop @ $I = 400\text{ }\mu\text{A}$, $V_{\text{SUP}} = 10.5\text{ V}$	-	0.4	1.4	V	
$I_{\text{I/O_LEAK}}$	Leakage current, $I/O-X \leq V_{\text{SUP}}$	-	0.1	3.0	μA	
I/O pins when function selected is input						
$V_{\text{I/O_NTH}}$	Negative threshold	1.4	2.0	2.9	V	
$V_{\text{I/O_PTH}}$	Positive threshold	2.1	3.0	3.8	V	
$V_{\text{I/O_HYST}}$	Hysteresis	0.2	1.0	1.4	V	
$I_{\text{I/O_IN}}$	Input current, $I/O \leq V_{\text{SUP}}/2$	-5.0	1.0	5.0	μA	
$R_{\text{I/O-X}}$	I/O-0 and I/O-1 input resistor. I/O-0 (or I/O-1) selected in register, $2.0\text{ V} < V_{\text{I/O-X}} < 16\text{ V}$ (Guaranteed by design).	-	100	-	$\text{k}\Omega$	
VSENSE input						
$V_{\text{SENSE_TH}}$	VSENSE undervoltage threshold (Not active in LP modes)					
	Low Threshold	8.1	8.6	9.0	V	
	High threshold	-	-	9.1		
	Hysteresis	0.1	0.25	0.5		
R_{VSENSE}	Input resistor to GND. In all modes except in LP modes. (Guaranteed by design).	-	125	-	$\text{k}\Omega$	

Notes

21. Reset must be kept low

Table 6. Static electrical characteristics (continued)

Characteristics noted under conditions $5.5\text{ V} \leq V_{\text{SUP}} \leq 28\text{ V}$, $-40\text{ }^{\circ}\text{C} \leq T_{\text{A}} \leq 125\text{ }^{\circ}\text{C}$, unless otherwise noted. Typical values noted reflect the approximate parameter means at $T_{\text{A}} = 25\text{ }^{\circ}\text{C}$ under nominal conditions, unless otherwise noted.

Symbol	Characteristic	Min.	Typ.	Max.	Unit	Notes
Analog MUX output						
$V_{\text{OUT_MAX}}$	Output Voltage Range, with external resistor to GND >2.0 k Ω	0.0	-	$V_{\text{DD}} - 0.5$	V	
R_{MI}	Internal pull-down resistor for regulator output current sense	0.8	1.9	2.8	k Ω	
C_{MUX}	External capacitor at MUX OUTPUT (Guaranteed by design)	-	-	1.0	nF	(22)
TEMP_COEFF	Chip temperature sensor coefficient (Guaranteed by design and device characterization) $V_{\text{DD}} = 5.0\text{ V}$ $V_{\text{DD}} = 3.3\text{ V}$	20 13.2	21 13.9	22 14.6	mv/ $^{\circ}\text{C}$	
V_{TEMP}	Chip temperature: MUX-OUT voltage $V_{\text{DD}} = 5.0\text{ V}$, $T_{\text{A}} = 125\text{ }^{\circ}\text{C}$ $V_{\text{DD}} = 3.3\text{ V}$, $T_{\text{A}} = 125\text{ }^{\circ}\text{C}$	3.6 2.45	3.75 2.58	3.9 2.65	V	
$V_{\text{TEMP(GD)}}$	Chip temperature: MUX-OUT voltage (guaranteed by design and characterization) $T_{\text{A}} = -40\text{ }^{\circ}\text{C}$, $V_{\text{DD}} = 5.0\text{ V}$ $T_{\text{A}} = 25\text{ }^{\circ}\text{C}$, $V_{\text{DD}} = 5.0\text{ V}$ $T_{\text{A}} = -40\text{ }^{\circ}\text{C}$, $V_{\text{DD}} = 3.3\text{ V}$ $T_{\text{A}} = 25\text{ }^{\circ}\text{C}$, $V_{\text{DD}} = 3.3\text{ V}$	0.12 1.5 0.07 1.08	0.30 1.65 0.19 1.14	0.48 1.8 0.3 1.2	V	
$V_{\text{SENSE GAIN}}$	Gain for V_{SENSE} , with external 1.0 k 1% resistor $V_{\text{DD}} = 5.0\text{ V}$ $V_{\text{DD}} = 3.3\text{ V}$	5.42 8.1	5.48 8.2	5.54 8.3		
$V_{\text{SENSE OFFSET}}$	Offset for V_{SENSE} , with external 1.0 k 1% resistor	-20	-	20	mV	
$V_{\text{SUP/1 RATIO}}$	Divider ratio for $V_{\text{SUP/1}}$ $V_{\text{DD}} = 5.0\text{ V}$ $V_{\text{DD}} = 3.3\text{ V}$	5.335 7.95	5.5 8.18	5.665 8.45		
$V_{\text{I/O RATIO}}$	Attenuation/Gain ratio for I/O-0 and I/O-1 actual voltage: $V_{\text{DD}} = 5.0\text{ V}$, I/O = 16 V (Attenuation, MUX-OUT register bit 3 set to 1) $V_{\text{DD}} = 5.0\text{ V}$, (Gain, MUX-OUT register bit 3 set to 0) $V_{\text{DD}} = 3.3\text{ V}$, I/O = 16 V (Attenuation, MUX-OUT register bit 3 set to 1) $V_{\text{DD}} = 3.3\text{ V}$, (Gain, MUX-OUT register bit 3 set to 0)	3.8 - 5.6 -	4.0 2.0 5.8 1.3	4.2 - 6.2 -		
V_{REF}	Internal reference voltage $V_{\text{DD}} = 5.0\text{ V}$ $V_{\text{DD}} = 3.3\text{ V}$	2.45 1.64	2.5 1.67	2.55 1.7	V	
$I_{\text{DD_RATIO}}$	Current ratio between VDD output & I_{OUT} at MUX-OUT (I_{OUT} at MUX-OUT = $I_{\text{DD out}} / I_{\text{DD_RATIO}}$) At $I_{\text{OUT}} = 50\text{ mA}$ I_{OUT} from 25 to 150 mA	80 62.5	97 97	115 117		
SAFE output						
V_{OL}	SAFE low level, at $I = 500\text{ }\mu\text{A}$	0.0	0.2	1.0	V	
$I_{\text{SAFE-IN}}$	Safe leakage current (V_{DD} low, or device unpowered). V_{SAFE} 0 to 28 V.	-	0.0	1.0	μA	

Notes

22. When C is higher than C_{MUX} , a serial resistor must be inserted

Table 6. Static electrical characteristics (continued)

Characteristics noted under conditions $5.5\text{ V} \leq V_{\text{SUP}} \leq 28\text{ V}$, $-40\text{ }^{\circ}\text{C} \leq T_{\text{A}} \leq 125\text{ }^{\circ}\text{C}$, unless otherwise noted. Typical values noted reflect the approximate parameter means at $T_{\text{A}} = 25\text{ }^{\circ}\text{C}$ under nominal conditions, unless otherwise noted.

Symbol	Characteristic	Min.	Typ.	Max.	Unit	Notes
Interrupt						
V_{OL}	Output low voltage, $I_{\text{OUT}} = 1.5\text{ mA}$	-	0.2	1.0	V	
R_{PU}	Pull-up resistor	6.5	10	14	k Ω	
$V_{\text{OH-LPVDDON}}$	Output high level in LP V_{DD} ON mode (Guaranteed by design)	3.9	4.3		V	
V_{MAX}	Leakage current INT voltage = 10 V (to allow high-voltage on MCU INT pin)	-	35	100	μA	
I_{SINK}	Sink current, $V_{\text{INT}} > 5.0\text{ V}$, INT low state	2.5	6.0	10	mA	
MISO, MOSI, SCLK, CS pins						
V_{OL}	Output low voltage, $I_{\text{OUT}} = 1.5\text{ mA}$ (MISO)	-	-	1.0	V	
V_{OH}	Output high voltage, $I_{\text{OUT}} = -0.25\text{ mA}$ (MISO)	$V_{\text{DD}} - 0.9$	-		V	
V_{IL}	Input low voltage (MOSI, SCLK, CS)	-	-	$0.3 \times V_{\text{DD}}$	V	
V_{IH}	Input high voltage (MOSI, SCLK, CS)	$0.7 \times V_{\text{DD}}$	-	-	V	
I_{HZ}	Tri-state leakage current (MISO)	-2.0	-	2.0	μA	
I_{PU}	Pull-up current (CS)	200	370	500	μA	
CAN logic input pins (TXD)						
V_{IH}	High Level Input Voltage	$0.7 \times V_{\text{DD}}$	-	$V_{\text{DD}} + 0.3$	V	
V_{IL}	Low Level Input Voltage	-0.3	-	$0.3 \times V_{\text{DD}}$	V	
I_{PDWN}	Pull-up Current, TXD, $V_{\text{IN}} = 0\text{ V}$ $V_{\text{DD}} = 5.0\text{ V}$ $V_{\text{DD}} = 3.3\text{ V}$	-850 -500	-650 -250	-200 -175	μA	
CAN data output pins (RXD)						
$V_{\text{OUT_LOW}}$	Low Level Output Voltage $I_{\text{RXD}} = 5.0\text{ mA}$	0.0	-	$0.3 \times V_{\text{DD}}$	V	
$V_{\text{OUT_HIGH}}$	High Level Output Voltage $I_{\text{RX}} = -3.0\text{ mA}$	$0.7 \times V_{\text{DD}}$	-	V_{DD}	V	
$I_{\text{OUT_HIGH}}$	High Level Output Current $V_{\text{RXD}} = V_{\text{DD}} - 0.4\text{ V}$	2.5	5.0	9.0	mA	
$I_{\text{OUT_LOW}}$	Low Level Input Current $V_{\text{RXD}} = 0.4\text{ V}$	2.5	5.0	9.0	mA	

Table 6. Static electrical characteristics (continued)

Characteristics noted under conditions $5.5\text{ V} \leq V_{\text{SUP}} \leq 28\text{ V}$, $-40\text{ }^{\circ}\text{C} \leq T_{\text{A}} \leq 125\text{ }^{\circ}\text{C}$, unless otherwise noted. Typical values noted reflect the approximate parameter means at $T_{\text{A}} = 25\text{ }^{\circ}\text{C}$ under nominal conditions, unless otherwise noted.

Symbol	Characteristic	Min.	Typ.	Max.	Unit	Notes
CAN output pins (CANH, CANL)						
V_{COM}	Bus pins common mode voltage for full functionality	-12	-	12	V	
$V_{\text{CANH-VCANL}}$	Differential input voltage threshold	500	-	900	mV	
$V_{\text{DIFF-HYST}}$	Differential input hysteresis	50	-	-	mV	
R_{IN}	Input resistance	5.0	-	50	k Ω	
$R_{\text{IN-DIFF}}$	Differential input resistance	10	-	100	k Ω	
$R_{\text{IN-MATCH}}$	Input resistance matching	-3.0	0.0	3.0	%	
V_{CANH}	CANH output voltage ($45\ \Omega < R_{\text{BUS}} < 65\ \Omega$) TXD dominant state TXD recessive state	2.75 2.0	3.5 2.5	4.5 3.0	V	
V_{CANL}	CANL output voltage ($45\ \Omega < R_{\text{BUS}} < 65\ \Omega$) TXD dominant state TXD recessive state	0.5 2.0	1.5 2.5	2.25 3.0	V	
$V_{\text{OH-VOL}}$	Differential output voltage ($45\ \Omega < R_{\text{BUS}} < 65\ \Omega$) TXD dominant state TXD recessive state	1.5 -0.5	2.0 0.0	3.0 0.05	V	
I_{CANH}	CAN H output current capability - Dominant state	-	-	-30	mA	
I_{CANL}	CAN L output current capability - Dominant state	30	-	-	mA	
$I_{\text{CANL-OC}}$	CANL overcurrent detection - Error reported in register	75	120	195	mA	
$I_{\text{CANH-OC}}$	CANH overcurrent detection - Error reported in register	-195	-120	-75	mA	
R_{INSLEEP}	CANH, CANL input resistance to GND, device supplied, CAN in Sleep mode, V_{CANH} , V_{CANL} from 0 to 5.0 V	5.0	-	50	k Ω	
V_{CANLP}	CANL, CANH output voltage in LP V_{DD} OFF and LP V_{DD} ON modes	-0.1	0.0	0.1	V	
$I_{\text{CAN-UN_SUP1}}$	CANH, CANL input current, V_{CANH} , $V_{\text{CANL}} = 0$ to 5.0 V, device unpowered (V_{SUP} , VDD, 5V-CAN: open).	-	3.0	10	μA	(23)
$I_{\text{CAN-UN_SUP2}}$	CANH, CANL input current, V_{CANH} , $V_{\text{CANL}} = -2.0$ to 7.0 V, device unpowered (V_{SUP} , VDD, 5V-CAN: open).	-	-	250	μA	(23)
$V_{\text{DIFF-R-LP}}$	Differential voltage for recessive bit detection in LP mode	-	-	0.4	V	(24)
$V_{\text{DIFF-D-LP}}$	Differential voltage for dominant bit detection in LP mode	1.15	-	-	V	(24)

CANH and CANL diagnostic information

V_{LG}	CANL to GND detection threshold	1.6	1.75	2.0	V	
V_{HG}	CANH to GND detection threshold	1.6	1.75	2.0	V	
V_{LVB}	CANL to VBAT detection threshold, V_{SUP1} and $V_{\text{SUP2}} > 8.0\text{ V}$	-	$V_{\text{SUP}} - 2.0$	-	V	
V_{HVB}	CANH to VBAT detection threshold, V_{SUP1} and $V_{\text{SUP2}} > 8.0\text{ V}$	-	$V_{\text{SUP}} - 2.0$	-	V	
V_{L5}	CANL to VDD detection threshold	4.0	$V_{\text{DD}} - 0.43$	-	V	
V_{H5}	CANH to VDD detection threshold	4.0	$V_{\text{DD}} - 0.43$	-	V	

Notes

23. V_{SUP} , VDD, 5V-CAN: shorted to GND, or connected to GND via a 47 k resistor instances are guaranteed by design and device characterization.
 24. Guaranteed by design and device characterization.

Table 6. Static electrical characteristics (continued)

Characteristics noted under conditions $5.5\text{ V} \leq V_{\text{SUP}} \leq 28\text{ V}$, $-40\text{ }^{\circ}\text{C} \leq T_{\text{A}} \leq 125\text{ }^{\circ}\text{C}$, unless otherwise noted. Typical values noted reflect the approximate parameter means at $T_{\text{A}} = 25\text{ }^{\circ}\text{C}$ under nominal conditions, unless otherwise noted.

Symbol	Characteristic	Min.	Typ.	Max.	Unit	Notes
SPLIT						
V_{SPLIT}	Output voltage Loaded condition $I_{\text{SPLIT}} = \pm 500\text{ }\mu\text{A}$ Unloaded condition $R_{\text{measure}} > 1.0\text{ M}\Omega$	$0.3 \times V_{\text{DD}}$ $0.45 \times V_{\text{DD}}$	$0.5 \times V_{\text{DD}}$ $0.5 \times V_{\text{DD}}$	$0.7 \times V_{\text{DD}}$ $0.55 \times V_{\text{DD}}$	V	
I_{LSPLIT}	Leakage current $-12\text{ V} < V_{\text{SPLIT}} < +12\text{ V}$ $-22\text{ to }-12\text{ V} < V_{\text{SPLIT}} < +12\text{ to }+35\text{ V}$	- -	0.0 -	5.0 200	μA	
LIN terminals (LIN-T1, LIN-T2)						
$V_{\text{LT_HS DRP}}$	LIN-T1, LIN-T2, HS switch drop @ $I = -20\text{ mA}$, $V_{\text{SUP}} > 10.5\text{ V}$	-	1.0	1.4	V	
LIN1 & LIN2 33903D/5D pin - LIN 33903S/5S pin (parameters guaranteed for $V_{\text{SUP}1}$, $V_{\text{SUP}2} 7.0\text{ V} \leq V_{\text{SUP}} \leq 18\text{ V}$)						
V_{BAT}	Operating Voltage Range	8.0	-	18	V	
V_{SUP}	Supply Voltage Range	7.0	-	18	V	
$I_{\text{BUS_LIM}}$	Current Limitation for Driver Dominant State Driver ON, $V_{\text{BUS}} = 18\text{ V}$	40	90	200	mA	
$I_{\text{BUS_PAS_DOM}}$	Input Leakage Current at the receiver Driver off; $V_{\text{BUS}} = 0\text{ V}$; $V_{\text{BAT}} = 12\text{ V}$	-1.0	-	-	mA	
$I_{\text{BUS_PAS_REC}}$	Leakage Output Current to GND Driver Off; $8.0\text{ V} < V_{\text{BAT}} < 18\text{ V}$; $8.0\text{ V} < V_{\text{BUS}} < 18\text{ V}$; $V_{\text{BUS}} \geq V_{\text{BAT}}$	-	-	20	μA	
$I_{\text{BUS_NO_GND}}$	Control unit disconnected from ground (Loss of local ground must not affect communication in the residual network) $G_{\text{NDDEVICE}} = V_{\text{SUP}}$; $V_{\text{BAT}} = 12\text{ V}$; $0 < V_{\text{BUS}} < 18\text{ V}$ (Guaranteed by design)	-1.0	-	1.0	mA	
$I_{\text{BUSNO_BAT}}$	V_{BAT} Disconnected; $V_{\text{SUP_DEVICE}} = G_{\text{ND}}$; $0 < V_{\text{BUS}} < 18\text{ V}$ (Node has to sustain the current that can flow under this condition. Bus must remain operational under this condition). (Guaranteed by design)	-	-	100	μA	
V_{BUSDOM}	Receiver Dominant State	-	-	0.4	V_{SUP}	
V_{BUSREC}	Receiver Recessive State	0.6	-	-	V_{SUP}	
$V_{\text{BUS_CNT}}$	Receiver Threshold Center $(V_{\text{TH_DOM}} + V_{\text{TH_REC}})/2$	0.475	0.5	0.525	V_{SUP}	
V_{HYS}	Receiver Threshold Hysteresis $(V_{\text{TH_REC}} - V_{\text{TH_DOM}})$	-	-	0.175	V_{SUP}	
V_{BUSWU}	LIN Wake-up threshold from LP V_{DD} ON or LP V_{DD} OFF mode	-	5.3	5.8	V	
R_{SLAVE}	LIN Pull-up Resistor to V_{SUP}	20	30	60	$\text{k}\Omega$	
$T_{\text{LINS D}}$	Overtemperature Shutdown (Guaranteed by design)	140	160	180	$^{\circ}\text{C}$	
$T_{\text{LINS D_HYS}}$	Overtemperature Shutdown Hysteresis (Guaranteed by design)	-	10	-	$^{\circ}\text{C}$	

5.3 Dynamic electrical characteristics

Table 7. Dynamic electrical characteristics

Characteristics noted under conditions $5.5\text{ V} \leq V_{\text{SUP}} \leq 28\text{ V}$, $-40\text{ }^{\circ}\text{C} \leq T_{\text{A}} \leq 125\text{ }^{\circ}\text{C}$, $\text{GND} = 0\text{ V}$, unless otherwise noted. Typical values noted reflect the approximate parameter means at $T_{\text{A}} = 25\text{ }^{\circ}\text{C}$ under nominal conditions, unless otherwise noted.

Symbol	Characteristic	Min.	Typ.	Max.	Unit	Notes
SPI timing						
FREQ	SPI Operation Frequency (MISO cap = 50 pF)	0.25	-	4.0	MHz	
t_{PCLK}	SCLK Clock Period	250	-	N/A	ns	
t_{WSCLKH}	SCLK Clock High Time	125	-	N/A	ns	
t_{WSCLKL}	SCLK Clock Low Time	125	-	N/A	ns	
t_{LEAD}	Falling Edge of $\overline{\text{CS}}$ to Rising Edge of SCLK 'C' and 'D' versions All others	30 550	- -	N/A N/A	ns	
t_{LEAD}	Falling Edge of $\overline{\text{CS}}$ to Rising Edge of SCLK when $\overline{\text{CS}}_{\text{low}}$ flag is set to '1' 'C' and 'D' versions All others	0.030 0.55	- -	2.5 2.5	μs	
t_{LAG}	Falling Edge of SCLK to Rising Edge of $\overline{\text{CS}}$	30	-	N/A	ns	
t_{SISU}	MOSI to Falling Edge of SCLK	30	-	N/A	ns	
t_{SIH}	Falling Edge of SCLK to MOSI	30	-	N/A	ns	
t_{RSO}	MISO Rise Time (CL = 50 pF)	-	-	30	ns	
t_{FSO}	MISO Fall Time (CL = 50 pF)	-	-	30	ns	
t_{SOEN}	Time from Falling to MISO Low-impedance	-	-	30	ns	
t_{SODIS}	Time from Rising to MISO High-impedance	-	-	30	ns	
t_{VALID}	Time from Rising Edge of SCLK to MISO Data Valid	-	-	30	ns	
$t_{\overline{\text{CS}}\text{LOW}}$	Delay between falling and rising edge on $\overline{\text{CS}}$ 'C' and 'D' versions All others	1.0 5.5	- -	N/A N/A	μs	
$t_{\overline{\text{CS}}\text{-TO}}$	$\overline{\text{CS}}$ Chip Select Low Timeout Detection	2.0	-	-	ms	
Supply, voltage regulator, reset						
$t_{\text{VS_LOW1/2_DGLT}}$	V_{SUP} undervoltage detector threshold deglitcher	30	50	100	μs	
$t_{\text{RISE-ON}}$	Rise time at turn ON. V_{DD} from 1.0 to 4.5 V. 2.2 μF at the VDD pin.	50	250	800	μs	
$t_{\text{RST-DGLT}}$	Deglitcher time to set $\overline{\text{RST}}$ pin low	20	30	40	μs	
Reset pulse duration						
$t_{\text{RST-PULSE}}$	V_{DD} undervoltage (SPI selectable) short, default at power on when BATFAIL bit set medium medium long long	0.9 4.0 8.5 17	1.0 5.0 10 20	1.4 6.0 12 24	ms	
$t_{\text{RST-WD}}$	Watchdog reset	0.9	1.0	1.4	ms	
I/O input						
t_{IODT}	Deglitcher time (Guaranteed by design)	19	30	41	μs	
VSENSE input						
t_{BFT}	Undervoltage deglitcher time	30	-	100	μs	

Table 7. Dynamic electrical characteristics (continued)

Characteristics noted under conditions $5.5\text{ V} \leq V_{\text{SUP}} \leq 28\text{ V}$, $-40\text{ }^{\circ}\text{C} \leq T_{\text{A}} \leq 125\text{ }^{\circ}\text{C}$, $\text{GND} = 0\text{ V}$, unless otherwise noted. Typical values noted reflect the approximate parameter means at $T_{\text{A}} = 25\text{ }^{\circ}\text{C}$ under nominal conditions, unless otherwise noted.

Symbol	Characteristic	Min.	Typ.	Max.	Unit	Notes
Interrupt						
$t_{\text{INT-PULSE}}$	$\overline{\text{INT}}$ pulse duration (refer to SPI for selection. Guaranteed by design)					
	short (25 to 125 °C)	20	25	35	μs	
	short (-40 °C)	20	25	40		
	long (25 to 125 °C)	90	100	130		
long (-40 °C)	90	100	140			

State diagram timings

$t_{\text{D_NM}}$	Delay for SPI Timer A, Timer B or Timer C write command after entering Normal mode (No command should occur within $t_{\text{D_NM}}$. $t_{\text{D_NM}}$ delay definition: from $\overline{\text{CS}}$ rising edge of "Go to Normal mode (i.e. 0x5A00)" command to $\overline{\text{CS}}$ falling edge of "Timer write" command)	60	-	-	μs	
$t_{\text{TIMING-ACC}}$	Tolerance for: watchdog period in all modes, FWU delay, Cyclic sense period and active time, Cyclic Interrupt period, LP mode overcurrent (unless otherwise noted)	-10	-	10	%	(28)

CAN dynamic characteristics

t_{DOUT}	TXD Dominant State Timeout	300	600	1000	μs	
t_{DOM}	Bus dominant clamping detection	300	600	1000	μs	
t_{LRD}	Propagation loop delay TXD to RXD, recessive to dominant (Fast slew rate)	60	120	210	ns	
t_{TRD}	Propagation delay TXD to CAN, recessive to dominant	-	70	110	ns	
t_{RRD}	Propagation delay CAN to RXD, recessive to dominant	-	45	140	ns	
t_{LDR}	Propagation loop delay TXD to RXD, dominant to recessive (Fast slew rate)	100	120	200	ns	
t_{TDR}	Propagation delay TXD to CAN, dominant to recessive	-	75	150	ns	
t_{RDR}	Propagation delay CAN to RXD, dominant to recessive	-	50	140	ns	
$t_{\text{LOOP-MSL}}$	Loop time TXD to RXD, Medium Slew Rate (Selected by SPI) Recessive to Dominant Dominant to Recessive	-	200	-	ns	
		-	200	-		
$t_{\text{LOOP-SSL}}$	Loop time TXD to RXD, Slow Slew Rate (Selected by SPI) Recessive to Dominant Dominant to Recessive	-	300	-	ns	
		-	300	-		
$t_{\text{CAN-WU1-F}}$	CAN Wake-up filter time, single dominant pulse detection (See Figure 35)	0.5	2.0	5.0	μs	(25)
$t_{\text{CAN-WU3-F}}$	CAN Wake-up filter time, 3 dominant pulses detection	300	-	-	ns	(26)
$t_{\text{CAN-WU3-TO}}$	CAN Wake-up filter time, 3 dominant pulses detection timeout (See Figure 36)	-	-	120	μs	(27)

Notes

25. No Wake-up for single pulse shorter than $t_{\text{CAN-WU1}}$ min. Wake-up for single pulse longer than $t_{\text{CAN-WU1}}$ max.
26. Each pulse should be greater than $t_{\text{CAN-WU3-F}}$ min. Guaranteed by design, and device characterization.
27. The 3 pulses should occur within $t_{\text{CAN-WU3-TO}}$. Guaranteed by design, and device characterization.
28. Guaranteed by design.

Table 7. Dynamic electrical characteristics (continued)

Characteristics noted under conditions $5.5\text{ V} \leq V_{\text{SUP}} \leq 28\text{ V}$, $-40\text{ }^{\circ}\text{C} \leq T_{\text{A}} \leq 125\text{ }^{\circ}\text{C}$, $\text{GND} = 0\text{ V}$, unless otherwise noted. Typical values noted reflect the approximate parameter means at $T_{\text{A}} = 25\text{ }^{\circ}\text{C}$ under nominal conditions, unless otherwise noted.

Symbol	Characteristic	Min.	Typ.	Max.	Unit	Notes
--------	----------------	------	------	------	------	-------

LIN physical layer: driver characteristics for normal slew rate - 20.0 kBit/sec according to lin physical layer specification

Bus load R_{BUS} and C_{BUS} 1.0 nF / 1.0 k Ω , 6.8 nF / 660 Ω , 10 nF / 500 Ω . See [Figure 18](#), page 30.

D1	Duty Cycle 1: $TH_{\text{REC}(\text{MAX})} = 0.744 * V_{\text{SUP}}$ $TH_{\text{DOM}(\text{MAX})} = 0.581 * V_{\text{SUP}}$ $D1 = t_{\text{BUS_REC}(\text{MIN})} / (2 * t_{\text{BIT}})$, $t_{\text{BIT}} = 50\text{ }\mu\text{s}$, $7.0\text{ V} \leq V_{\text{SUP}} \leq 18\text{ V}$	0.396	-	-		
D2	Duty Cycle 2: $TH_{\text{REC}(\text{MIN})} = 0.422 * V_{\text{SUP}}$ $TH_{\text{DOM}(\text{MIN})} = 0.284 * V_{\text{SUP}}$ $D2 = t_{\text{BUS_REC}(\text{MAX})} / (2 * t_{\text{BIT}})$, $t_{\text{BIT}} = 50\text{ }\mu\text{s}$, $7.6\text{ V} \leq V_{\text{SUP}} \leq 18\text{ V}$	-	-	0.581		

LIN physical layer: driver characteristics for slow slew rate - 10.4 kBit/sec according to lin physical layer specification

Bus load R_{BUS} and C_{BUS} 1.0 nF / 1.0 k Ω , 6.8 nF / 660 Ω , 10 nF / 500 Ω . Measurement thresholds. See [Figure 19](#), page 31.

D3	Duty Cycle 3: $TH_{\text{REC}(\text{MAX})} = 0.778 * V_{\text{SUP}}$ $TH_{\text{DOM}(\text{MAX})} = 0.616 * V_{\text{SUP}}$ $D3 = t_{\text{BUS_REC}(\text{MIN})} / (2 * t_{\text{BIT}})$, $t_{\text{BIT}} = 96\text{ }\mu\text{s}$, $7.0\text{ V} \leq V_{\text{SUP}} \leq 18\text{ V}$	0.417	-	-		
D4	Duty Cycle 4: $TH_{\text{REC}(\text{MIN})} = 0.389 * V_{\text{SUP}}$ $TH_{\text{DOM}(\text{MIN})} = 0.251 * V_{\text{SUP}}$ $D4 = t_{\text{BUS_REC}(\text{MAX})} / (2 * t_{\text{BIT}})$, $t_{\text{BIT}} = 96\text{ }\mu\text{s}$, $7.6\text{ V} \leq V_{\text{SUP}} \leq 18\text{ V}$	-	-	0.590		

LIN physical layer: driver characteristics for fast slew rate

SR _{FAST}	LIN Fast Slew Rate (Programming Mode)	-	20	-	V/ μs	
--------------------	---------------------------------------	---	----	---	------------------	--

LIN physical layer: characteristics and wake-up timings. V_{SUP} from 7.0 to 18 V, bus load R_{BUS} and C_{BUS} 1.0 nF / 1.0 k Ω , 6.8 nF / 660 Ω , 10 nF / 500 Ω . See [Figure 18](#), page 30.

$t_{\text{REC_PD}}$ $t_{\text{REC_SYM}}$	Propagation Delay and Symmetry (See Figure 18 , page 30 and Figure 19 , page 31) Propagation Delay of Receiver, $t_{\text{REC_PD}} = \text{MAX}(t_{\text{REC_PDR}}, t_{\text{REC_PDF}})$ Symmetry of Receiver Propagation Delay, $t_{\text{REC_PDF}} - t_{\text{REC_PDR}}$	- -2.0	4.2 -	6.0 2.0	μs	
t_{PROPWL}	Bus Wake-up Deglitcher (LP V_{DD} OFF and LP V_{DD} ON modes) (See Figure 20 , page 30 for LP V_{DD} OFF mode and Figure 21 , page 31 for LP mode)	42	70	95	μs	
$t_{\text{WAKE_LPVDDOFF}}$ $t_{\text{WAKE_LPVDDON}}$	Bus Wake-up Event Reported From LP V_{DD} OFF mode From LP V_{DD} ON mode	- 1.0	- -	1500 12	μs	
t_{TXDDOM}	TXD Permanent Dominant State Delay (Guaranteed by design)	0.65	1.0	1.35	s	

5.4 Timing diagrams

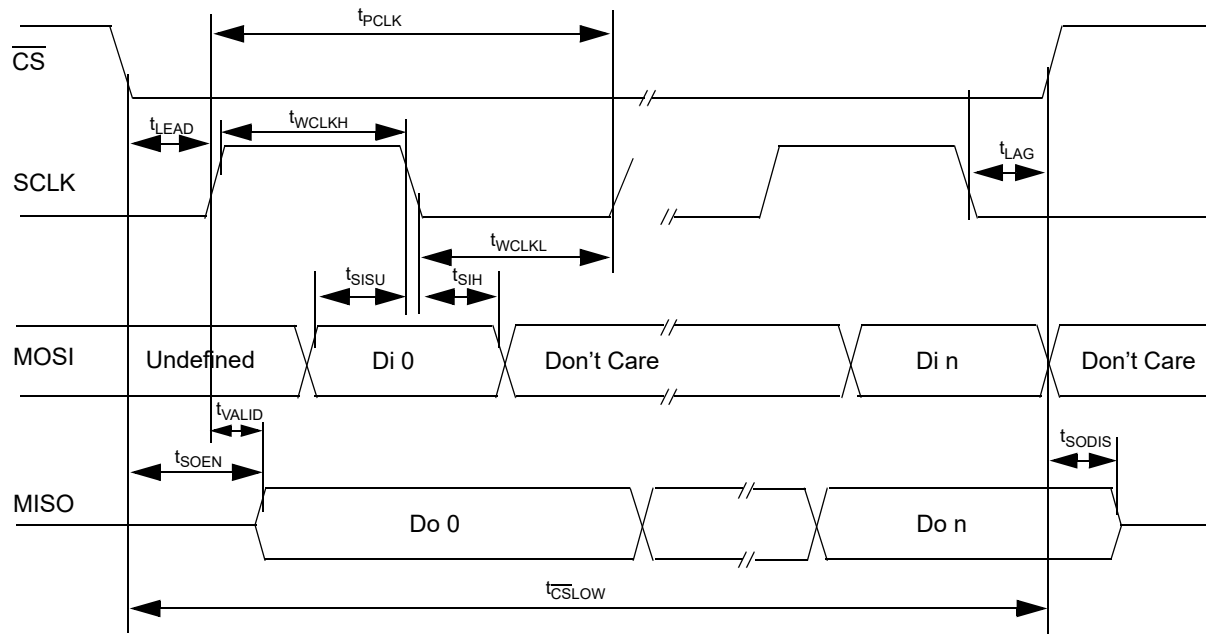

Figure 14. SPI timing

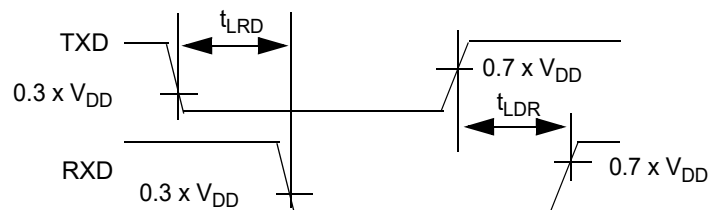

Figure 15. CAN signal propagation loop delay TXD to RXD

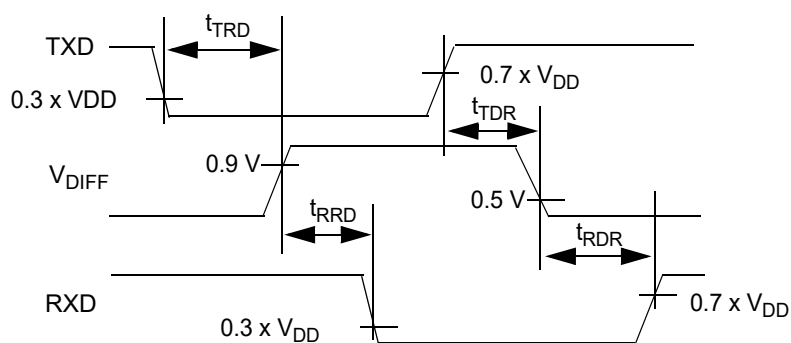

Figure 16. CAN signal propagation delays TXD to CAN and CAN to RXD

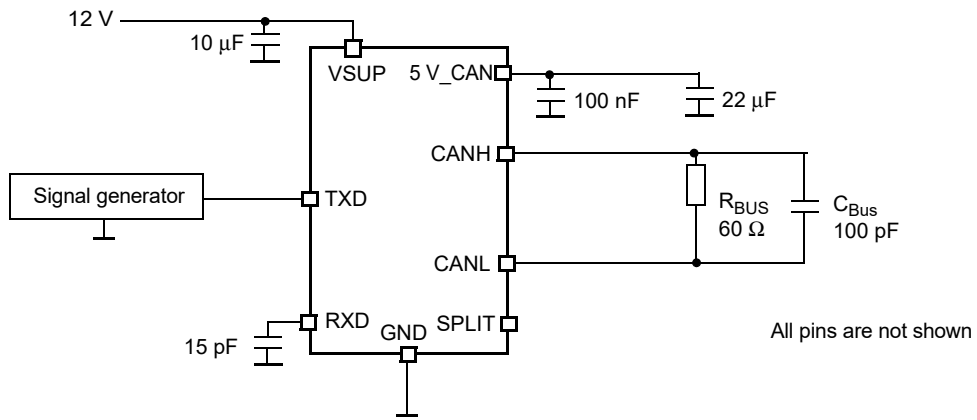

Figure 17. Test circuit for CAN timing characteristics

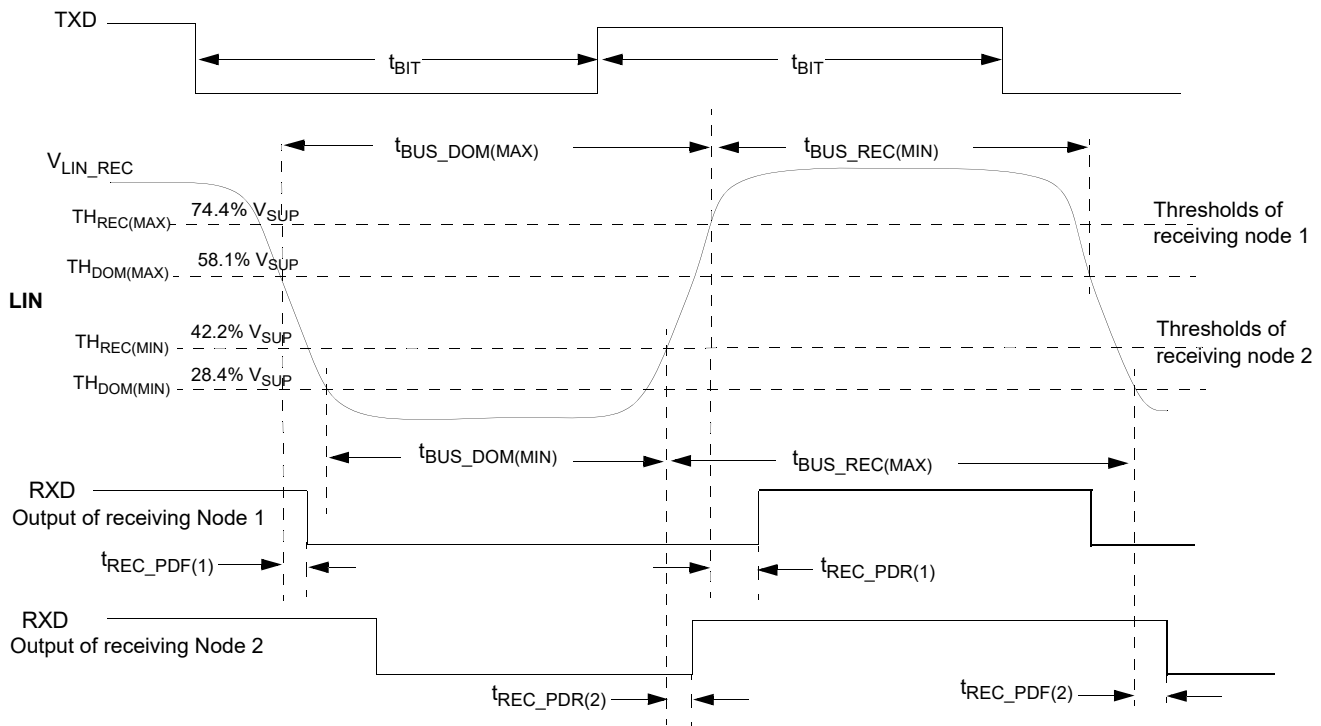

Figure 18. LIN timing measurements for normal slew rate

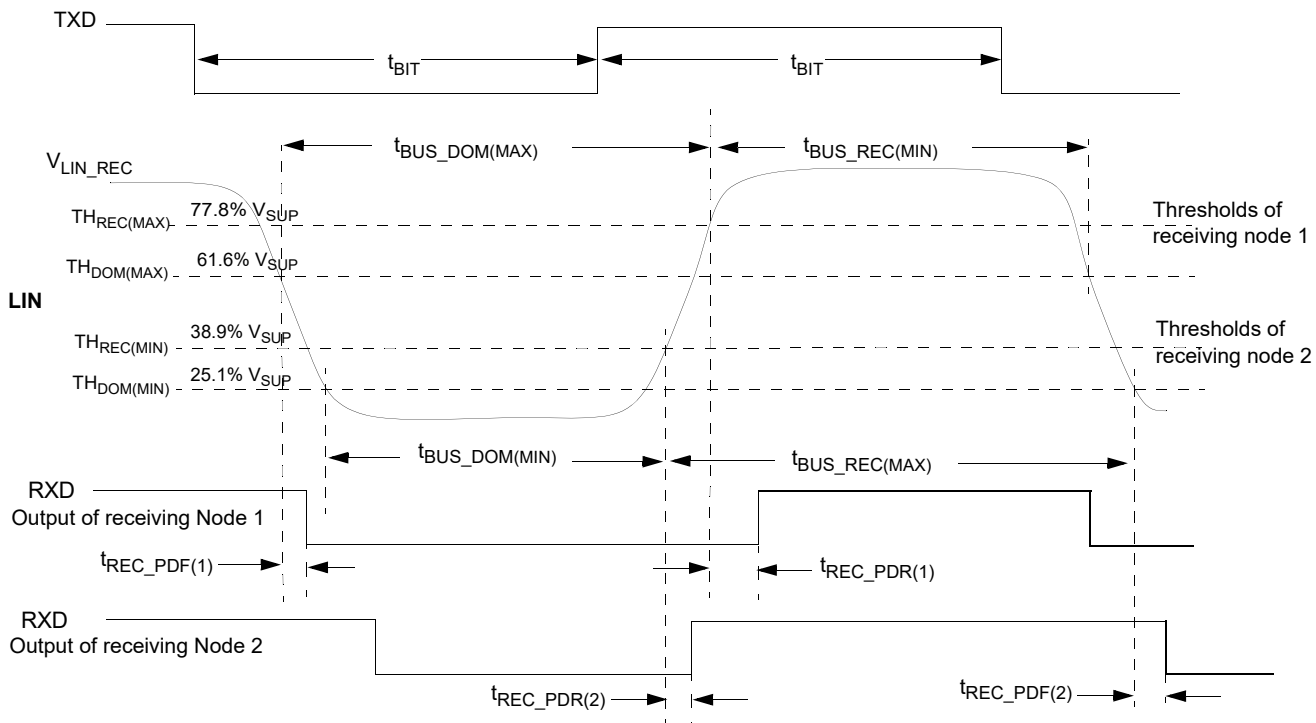

Figure 19. LIN timing measurements for slow slew rate

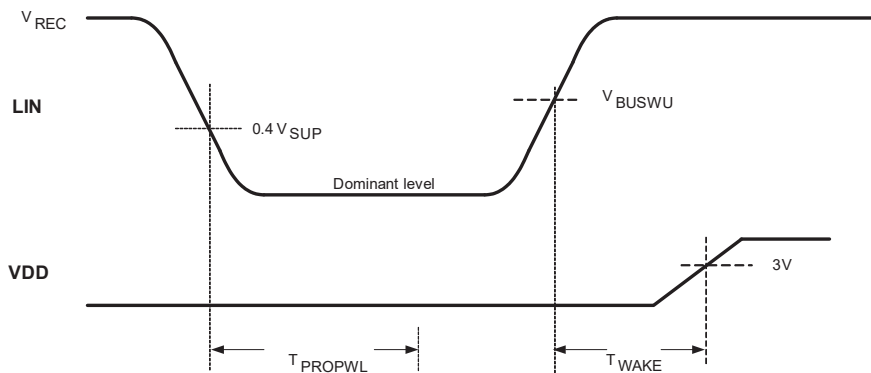

Figure 20. LIN wake-up LP V_{DD} off mode timing

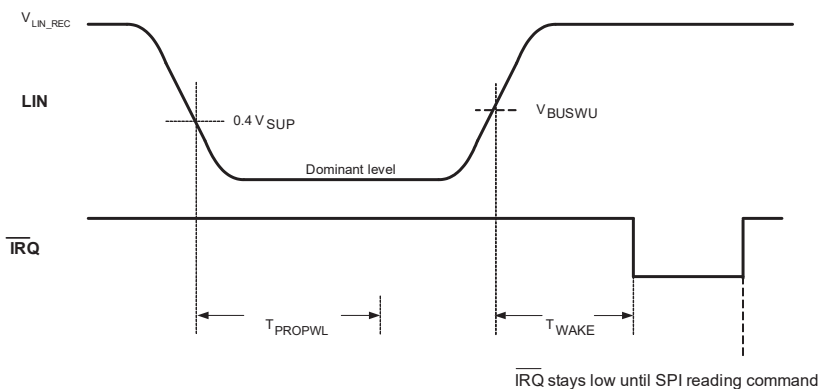

Figure 21. LIN Wake-up LP V_{DD} ON Mode Timing

\overline{IRQ} stays low until SPI reading command

6 Functional description

6.1 Introduction

The MC33903_4_5 is the second generation of System Basis Chip, combining:

- Advanced power management unit for the MCU, the integrated CAN interface and for the additional ICs such as sensors, CAN transceiver.
- Built in enhanced high speed CAN interface (ISO11898-2 and -5), with local and bus failure diagnostic, protection, and fail-safe operation mode.
- Built in LIN interface, compliant to LIN 2.1 and J2602-2 specification, with local and bus failure diagnostic and protection.
- Innovative hardware configurable fail-safe state machine solution.
- Multiple LP modes, with low current consumption.
- Family concept with pin compatibility; with and without LIN interface devices.

6.2 Functional pin description

6.2.1 Power supply (VSUP/1 and VSUP2)

Note: VSUP1 and VSUP2 supplies are externally available on all devices except the 33903D, 33903S, and 33903P, where these are connected internally.

VSUP1 is the input pin for the internal supply and the VDD regulator. VSUP2 is the input pin for the 5 V-CAN regulator, LIN's interfaces and I/O functions. The VSUP block includes over and undervoltage detections which can generate interrupt. The device includes a loss of battery detector connected to VSUP/1.

Loss of battery is reported through a bit (called BATFAIL). This generates a POR (Power On Reset).

6.2.2 VDD voltage regulator (VDD)

The regulator has two main modes of operation (Normal mode and LP mode). It can operate with or without an external PNP transistor. In Normal mode, without external PNP, the max DC capability is 150 mA. Current limitation, temperature pre-warning flag and overtemperature shutdown features are included. When V_{DD} is turned ON, rise time from 0 to 5.0 V is controlled. Output voltage is 5.0 V. A 3.3 V option is available via dedicated part number.

If current higher than 150 mA is required, an external PNP transistor must be connected to VE (PNP emitter) and VB (PNP base) pins, in order to increase total current capability and share the power dissipation between internal VDD transistor and the external transistor. See [External transistor Q1 \(VE and VB\)](#). The PNP can be used even if current is less than 150 mA, depending upon ambient temperature, maximum supply and thermal resistance. Typically, above 100-200 mA, an external ballast transistor is recommended.

6.2.3 VDD regulator in LP mode

When the device is set in LP V_{DD} ON mode, the V_{DD} regulator is able to supply the MCU with a DC current below typically 1.5 mA (I_{P-ITH}). Transient current can also be supplied up to a tenth of a mA. Current in excess of 1.5 mA is detected, and this event is managed by the device logic (Wake-up detection, timer start for overcurrent duration monitoring or watchdog refresh).

6.2.4 External transistor Q1 (VE and VB)

The device has a dedicated circuit to allow usage of an external "P" type transistor, with the objective to share the power dissipation between the internal transistor of the V_{DD} regulator and the external transistor. The recommended bipolar PNP transistor is MJD42C or BCP52-16.

When the external PNP is connected, the current is shared between the internal path transistor and the external PNP, with the following typical ratio: 1/3 in the internal transistor and 2/3 in the external PNP. The PNP activation and control is done by SPI.

The device is able to operate without an external transistor. In this case, the VE and VB pins must remain open.

6.2.5 5 V-CAN voltage regulator for CAN and analog MUX

This regulator is supplied from the VSUP/2 pin. A capacitor is required at 5 V-CAN pin. Analog MUX and part of the LIN interfaces are supplied from 5 V-CAN. Consequently, the 5 V-CAN must be ON in order to have Analog MUX operating and to have the LIN interface operating in TXD/RXD mode.

The 5 V-CAN regulator is OFF by default and must be turned ON by SPI. In Debug mode, the 5 V-CAN is ON by default.

6.2.6 V auxiliary output, 5.0 and 3.3 V selectable (VB-Aux, VC-Aux, and VCaux) - Q2

The VAUX block is used to provide an auxiliary voltage output, 5.0 or 3.3 V, selectable by the SPI. It uses an external PNP pass transistor for flexibility and power dissipation constraints. The external recommended bipolar transistors are MJD42C or BCP52-16.

An overcurrent and undervoltage detectors are provided.

V_{AUX} is controlled via the SPI, and can be turned ON or OFF. V_{AUX} low threshold detection and overcurrent information will disable V_{AUX} , and are reported in the SPI and can generate \overline{INT} . V_{AUX} is OFF by default and must be turned ON by the SPI.

6.2.7 Undervoltage reset and reset function (\overline{RST})

The \overline{RST} pin is an open drain structure with an internal pull-up resistor. The LS driver has limited current capability when asserted low, in order to tolerate a short to 5.0 V. The \overline{RST} pin voltage is monitored in order to detect failure (e.g. \overline{RST} pin shorted to 5.0 V or GND).

The \overline{RST} pin reports an undervoltage condition to the MCU at the VDD pin, as a \overline{RST} failure in the watchdog refresh operation. V_{DD} undervoltage reset also operates in LP V_{DD} ON mode.

Two V_{DD} undervoltage thresholds are included. The upper (typically 4.65 V, $R_{ST-TH1-5}$) can lead to a Reset or an Interrupt. This is selected by the SPI. When " $R_{ST-TH2-5}$ " is selected, in Normal mode, an \overline{INT} is asserted when VDD falls below " $R_{ST-TH1-5}$ "; then, when V_{DD} falls below " $R_{ST-TH2-5}$ " a Reset will occur. This will allow the MCU to operate in a degraded mode (i.e., with 4.0 V V_{DD}).

6.2.8 I/O pins (I/O-0: I/O-3)

I/Os are configurable input/output pins. They can be used for small loads or to drive external transistors. When used as output drivers, the I/Os are either a HS or LS type. They can also be set to high-impedance. I/Os are controlled by the SPI and at power on, the I/Os are set as inputs. They include overload protection by temperature or excess of a voltage drop.

When I/O-0/-1/-2/-3 voltage is greater than VSUP/2 voltage, the leakage current (I_{I/O_LEAK}) parameter is not applicable

- I/O-0 and I/O-1 will have current flowing into the device through three diodes limited by an 80 kOhm resistor (in series).
- I/O-2 and I/O-3 will have unlimited current flowing into the device through one diode.

In LP mode, the state of the I/O can be turned ON or OFF, with extremely low power consumption (except when there is a load). Protection is disabled in LP mode. When cyclic sense is used, I/O-0 is the HS/LS switch, I/O-1, -2 and -3 are the wake inputs. I/O-2 and I/O-3 pins share the LIN Master pin function.

6.2.9 VSENSE input (VSENSE)

This pin can be connected to the battery line (before the reverse battery protection diode), via a serial resistor and a capacitor to GND. It incorporates a threshold detector to sense the battery voltage and provide a battery early warning. It also includes a resistor divider to measure the V_{SENSE} voltage via the MUX-OUT pin.

6.2.10 MUX-output (MUXOUT)

The MUX-OUT pin ([Figure 22](#)) delivers an analog voltage to the MCU A/D input. The voltage to be delivered to MUX-OUT is selected via the SPI, from one of the following functions: $V_{SUP/1}$, V_{SENSE} , I/O-0, I/O-1, Internal 2.5 V reference, die temperature sensor, V_{DD} current copy.

Voltage divider or amplifier is inserted in the chain, as shown in [Figure 22](#).

For the V_{DD} current copy, a resistor must be added to the MUX-OUT pin, to convert current into voltage. Device includes an internal 2.0 k resistor selectable by the SPI.

Voltage range at MUX-OUT is from GND to VDD. It is automatically limited to V_{DD} (max 3.3 V for 3.3 V part numbers).

The MUX-OUT buffer is supplied from 5 V-CAN regulator, so the 5 V-CAN regulator must be ON in order to have:

- 1) MUX-OUT functionality and
- 2) SPI selection of the analog function.

If the 5 V-CAN is OFF, the MUX-OUT voltage is near GND and the SPI command that selects one of the analog inputs is ignored.

Delay must be respected between SPI commands for 5 V-CAN turned ON and SPI to select MUX-OUT function. The delay depends mainly upon the 5 V-CAN capacitor and load on 5 V-CAN.

The delay can be estimated using the following formula: $\text{delay} = C(5 \text{ V-CAN}) \times U(5.0 \text{ V}) / I_{\text{lim}} 5 \text{ V-CAN}$.

C = cap at 5 V-CAN regulator, U = 5.0 V,

$I_{\text{LIM}} 5 \text{ V-CAN}$ = min current limit of 5 V-CAN regulator (parameter 5 V-C ILIM).

Note:

As there is no link between 5VCAN and VDD, the 5VCAN can starts after both the VDD and RSTB are released. To ensure the MCU can use MUXOUT output information, it must verify the presence of the 5VCAN. This can be done for instance by checking the 5VCAN undervoltage flag (bit4 of the 0xDF00 SPI command).

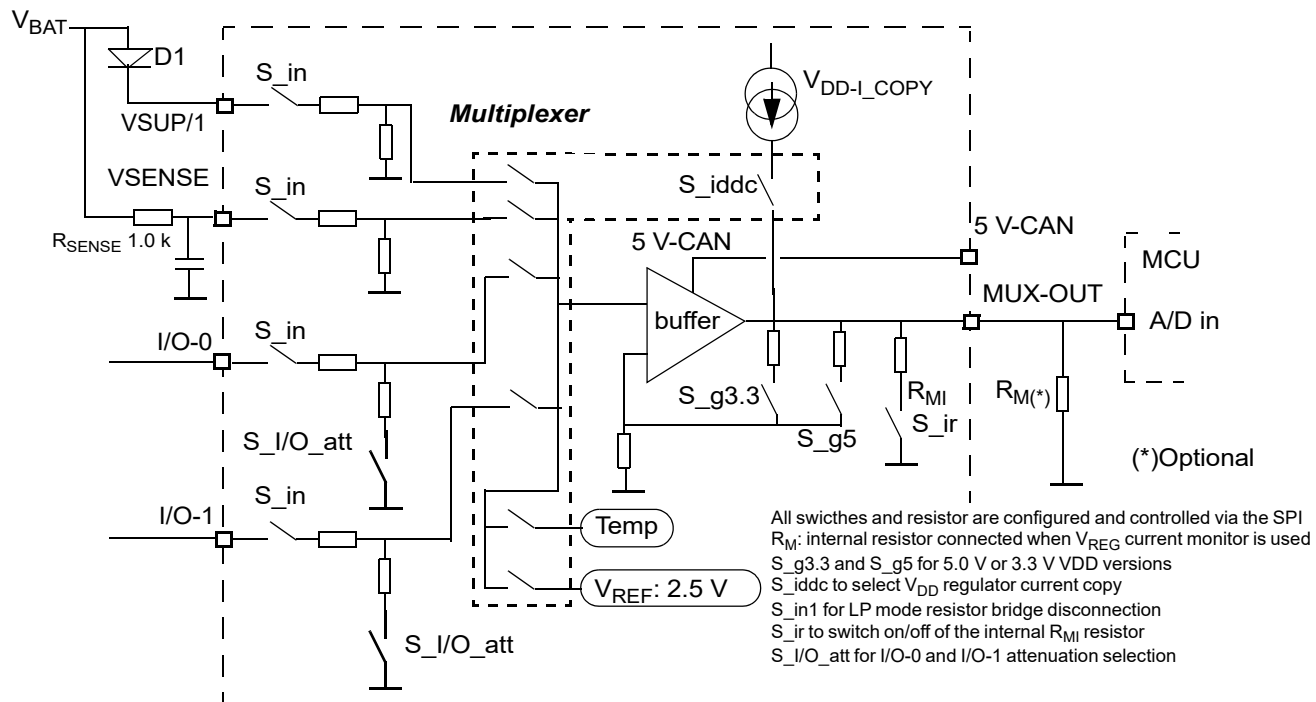

Figure 22. Analog multiplexer block diagram

6.2.11 DGB (DGB) and debug mode

6.2.11.1 Primary function

It is an input used to set the device in Debug mode. This is achieved by applying a voltage between 8.0 and 10 V at the DEBUG pin and then, powering up the device (See [State diagram](#)). When the device leaves the INIT Reset mode and enters into INIT mode, it detects the voltage at the DEBUG pin to be between a range of 8.0 to 10 V, and activates the Debug mode.

When Debug mode is detected, no Watchdog SPI refresh commands are necessary. This allows an easy debug of the hardware and software routines (i.e. SPI commands).

When the device is in Debug mode it is reported by the SPI flag. While in Debug mode, and the voltage at DBG pin falls below the 8.0 to 10 V range, the Debug mode is left, and the device starts the watchdog operation, and expects the proper watchdog refresh. The Debug mode can be left by SPI. This is recommended to avoid staying in Debug mode when an unwanted Debug mode selection (FMEA pin) is present. The SPI command has a higher priority than providing 8.0 to 10 V at the DEBUG pin.

6.2.11.2 Secondary function

The resistor connected between the DBG pin and the GND selects the Fail-Safe mode operation. DBG pin can also be connected directly to GND (this prevents the usage of Debug mode).

Flexibility is provided to select SAFE output operation via a resistor at the DBG pin or via a SPI command. The SPI command has higher priority than the hardware selection via Debug resistor. When the Debug mode is selected, the SAFE modes cannot be configured via the resistor connected at DBG pin.

6.2.12 SAFE

6.2.12.1 Safe output pin

This pin is an output and is asserted low when a fault event occurs. The objective is to drive electrical safe circuitry and set the ECU in a known state, independent of the MCU and SBC, once a failure has been detected. The SAFE output structure is an open drain, without a pull-up.

6.2.13 Interrupt ($\overline{\text{INT}}$)

The $\overline{\text{INT}}$ output pin is asserted low or generates a low pulse when an interrupt condition occurs. The $\overline{\text{INT}}$ condition is enabled in the $\overline{\text{INT}}$ register. The selection of low level or pulse and pulse duration are selected by SPI.

No current will flow inside the $\overline{\text{INT}}$ structure when V_{DD} is low, and the device is in LP V_{DD} OFF mode. This allows the connection of an external pull-up resistor and connection of an $\overline{\text{INT}}$ pin from other ICs without extra consumption in unpowered mode.

$\overline{\text{INT}}$ has an internal pull-up structure to V_{DD} . In LP V_{DD} ON mode, a diode is inserted in series with the pull-up, so the high level is slightly lower than in other modes.

6.2.14 CANH, CANL, SPLIT, RXD, TXD

These are the pins of the high speed CAN physical interface, between the CAN bus and the micro controller. A detail description is provided in the document.

6.2.15 LIN, LIN-T, TXDL and RXDL

These are the pins of the LIN physical interface. Device contains zero, one or two LIN interfaces.

The MC33903, MC33903P, and MC33904 do not have a LIN interface. However, the MC33903S/5S (S = Single) and MC33903D/5D (D=Dual) contain 1 and 2 LIN interfaces, respectively.

LIN, LIN1 and LIN2 pins are the connection to the LIN sub buses. LIN interfaces are connected to the MCU via the TXD, TXD-L1 and TXD-L2 and RXD, RXD-L1 and RXD-L2 pins.

The device also includes one or two HS switches to VSUP/2 pin which can be used as a LIN master termination switch. Pins LINT, LINT-1 and LINT-2 pins are the same as I/O-2 and I/O-3.

7 Functional device operation

7.1 Mode and state description

The device has several operation modes. The transitions and conditions to enter or leave each mode are illustrated in the state diagram.

7.1.1 INIT reset

This mode is automatically entered after the device is “powered on”. In this mode, the $\overline{\text{RST}}$ pin is asserted low, for a duration of typically 1.0 ms. Control bits and flags are ‘set’ to their default reset condition. The BATFAIL is set to indicate the device is coming from an unpowered condition, and all previous device configurations are lost and “reset” the default value. The duration of the INIT reset is typically 1.0 ms.

INIT reset mode is also entered from INIT mode if the expected SPI command does not occur in due time (Ref. INIT mode), and if the device is not in the debug mode.

7.1.2 INIT

This mode is automatically entered from the INIT Reset mode. In this mode, the device must be configured via SPI within a time of 256 ms max. Four registers called INIT Wdog, INIT REG, INIT LIN I/O and INIT MISC must be, and can only be configured during INIT mode. Other registers can be written in this and other modes.

Once the INIT register configuration is done, a SPI Watchdog Refresh command must be sent in order to set the device into Normal mode. If the SPI watchdog refresh does not occur within the 256 ms period, the device will return into INIT Reset mode for typically 1.0 ms, and then re enter into INIT mode.

Register read operation is allowed in INIT mode to collect device status or to read back the INIT register configuration.

When INIT mode is left by a SPI watchdog refresh command, it is only possible to re-enter the INIT mode using a secured SPI command. In INIT mode, the CAN, LIN1, LIN2, VAUX, I/O_x and Analog MUX functions are not operating. The 5 V-CAN is also not operating, except if the Debug mode is detected.

7.1.3 Reset

In this mode, the $\overline{\text{RST}}$ pin is asserted low. Reset mode is entered from Normal mode, Normal Request mode, LP V_{DD} ON mode and from the Flash mode when the watchdog is not triggered, or if a V_{DD} low condition is detected.

The duration of reset is typically 1.0 ms by default. You can define a longer Reset pulse activation only when the Reset mode is entered following a V_{DD} low condition. Reset pulse is always 1.0 ms, when reset mode is entered due to wrong watchdog refresh command.

Reset mode can be entered via the secured SPI command.

7.1.4 Normal request

This mode is automatically entered after RESET mode, or after a Wake-up from LP V_{DD} ON mode.

A watchdog refresh SPI command is necessary to transition to NORMAL mode. The duration of the Normal request mode is 256 ms when Normal Request mode is entered after RESET mode. Different durations can be selected by SPI when normal request is entered from LP V_{DD} ON mode.

If the watchdog refresh SPI command does not occur within the 256 ms (or the shorter user defined time out), then the device will enter into RESET mode for a duration of typically 1.0 ms.

Note: in init reset, init, reset and normal request modes as well as in LP modes, the V_{DD} external PNP is disabled.

7.1.5 Normal

In this mode, all device functions are available. This mode is entered by a SPI watchdog refresh command from Normal Request mode, or from INIT mode.

During Normal mode, the device watchdog function is operating, and a periodic watchdog refresh must occur. When an incorrect or missing watchdog refresh command is initiated, the device will enter into Reset mode.

While in Normal mode, the device can be set to LP modes (LP V_{DD} ON or LP V_{DD} OFF) using the SPI command. Dedicated, secured SPI commands must be used to enter from Normal mode to Reset mode, INIT mode or Flash mode.

7.1.6 Flash

In this mode, the software watchdog period is extended up to typically 32 seconds. This allow programming of the MCU flash memory while minimizing the software over head to refresh the watchdog. The flash mode is entered by Secured SPI command and is left by SPI command. Device will enter into Reset mode. When an incorrect or missing watchdog refresh command device will enter into Reset mode. An interrupt can be generated at 50% of the watchdog period.

CAN interface operates in Flash mode to allow flash via CAN bus, inside the vehicle.

7.1.7 Debug

Debug is a special operation mode of the device which allows for easy software and hardware debugging. The debug operation is detected after power up if the DBG pin is set to 8.0 to 10 V range.

When debug is detected, all the software watchdog operations are disabled: 256 ms of INIT mode, watchdog refresh of Normal mode and Flash mode, Normal Request time out (256 ms or user defined value) are not operating and will not lead to transition into INIT reset or Reset mode.

When the device is in Debug mode, the SPI command can be sent without any time constraints with respect to the watchdog operation and the MCU program can be "halted" or "paused" to verify proper operation.

Debug can be left by removing 8 to 10 V from the DEBUG pin, or by the SPI command (Ref. to MODE register).

The 5 V-CAN regulator is ON by default in Debug mode.

7.2 LP modes

The device has two main LP modes: LP mode with V_{DD} OFF, and LP mode with V_{DD} ON.

Prior to entering into LP mode, I/O and CAN Wake-up flags must be cleared (Ref. to mode register). If the Wake-up flags are not cleared, the device will not enter into LP mode. In addition, the CAN failure flags (i.e. CAN_F and CAN_UF) must be cleared, in order to meet the LP current consumption specification.

7.2.1 LP - V_{DD} off

In this mode, V_{DD} is turned OFF and the MCU connected to VDD is unsupplied. This mode is entered using SPI. It can also be entered by an automatic transition due to fail-safe management. 5 V-CAN and V_{AUX} regulators are also turned OFF.

When the device is in LP V_{DD} OFF mode, it monitors external events to Wake-up and leave the LP mode. The Wake-up events can occur from:

- CAN
- LIN interface, depending upon device part number
- Expiration of an internal timer
- I/O-0, and I/O-1 inputs, and depending upon device part number and configuration, I/O-2 and/or -3 input
- Cyclic sense of I/O-1 input, associated by I/O-0 activation, and depending upon device part number and configuration, cyclic sense of I/O-2 and -3 input, associated by I/O-0 activation

When a Wake-up event is detected, the device enters into Reset mode and then into Normal Request mode. The Wake-up sources are reported to the device SPI registers. In summary, a Wake-up event from LP V_{DD} OFF leads to the V_{DD} regulator turned ON, and the MCU operation restart.

7.2.2 LP - V_{DD} ON

In this mode, the voltage at the VDD pin remains at 5.0 V (or 3.3 V, depending upon device part number). The objective is to maintain the MCU powered, with reduced consumption. In such mode, the DC output current is expected to be limited to 100 μ A or a few mA, as the ECU is in reduced power operation mode.

During this mode, the 5 V-CAN and V_{AUX} regulators are OFF. The optional external PNP at VDD will also be automatically disabled when entering this mode.

The same Wake-up events as in LP V_{DD} OFF mode (CAN, LIN, I/O, timer, cyclic sense) are available in LP V_{DD} on mode. In addition, two additional Wake-up conditions are available.

- Dedicated SPI command. When device is in LP V_{DD} ON mode, the Wake-up by SPI command uses a write to "Normal Request mode", 0x5C10.
- Output current from VDD exceeding L_{P-ITH} threshold.

In LP V_{DD} ON mode, the device is able to source several tenths of mA DC. The current source capability can be time limited, by a selectable internal timer. Timer duration is up to 32 ms, and is triggered when the output current exceed the output current threshold typically 1.5 mA.

This allows for instance, a periodic activation of the MCU, while the device remains in LP V_{DD} on mode. If the duration exceed the selected time (ex 32 ms), the device will detect a Wake-up.

Wake-up events are reported to the MCU via a low level pulse at \overline{INT} pulse. The MCU will detect the \overline{INT} pulse and resume operation.

7.2.2.1 Watchdog function in LP V_{DD} on mode

It is possible to enable the watchdog function in LP V_{DD} ON mode. In this case, the principle is timeout.

Refresh of the watchdog is done either by:

- a dedicated SPI command (different from any other SPI command or simple \overline{CS} activation which would Wake-up - Ref. to the previous paragraph)
- or by a temporary (less than 32 ms max) V_{DD} over current Wake-up ($I_{DD} > 1.5$ mA typically).

As long as the watchdog refresh occurs, the device remains in LP V_{DD} on mode.

7.2.2.2 Mode transitions

Mode transitions are either done automatically (i.e. after a timeout expired or voltage conditions), or via a SPI command, or by an external event such as a Wake-up. Some mode changes are performed using the Secured SPI commands.

7.4 Mode change

7.4.1 'Secured SPI' description

A request is done by a SPI command, the device provide on MISO an unpredictable 'random code'. Software must perform a logical change on the code and return it to the device with the new SPI command to perform the desired action.

The 'random code' is different at every exercise of the secured procedure and can be read back at any time.

The secured SPI uses the Special MODE register for the following transitions:

- from Normal mode to $\overline{\text{INT}}$ mode
- from Normal mode to Flash mode
- from Normal mode to Reset mode (reset request).

"Random code" is also used when the 'advance watchdog' is selected.

7.4.2 Changing of device critical parameters

Some critical parameters are configured one time at device power on only, while the batfail flag is set in the INIT mode. If a change is required while device is no longer in INIT mode, device must be set back in INIT mode using the "SPI secure" procedure.

7.5 Watchdog operation

7.5.1 In normal request mode

In Normal Request mode, the device expects to receive a watchdog configuration before the end of the normal request time out period. This period is reset to a long (256 ms) after power on and when BATFAIL is set.

The device can be configured to a different (shorter) time out period which can be used after Wake-up from LP V_{DD} ON mode.

After a software watchdog reset, the value is restored to 256 ms, in order to allow for a complete software initialization, similar to a device power up. In Normal Request mode the watchdog operation is "timeout" only and can be triggered/observed any time within the period.

7.5.2 Watchdog type selection

Three types of watchdog operation can be used:

- Window watchdog (default)
- Timeout operation
- Advanced

The selection of watchdog is performed in INIT mode. This is done after device power up and when the BATFAIL flag is set. The Watchdog configuration is done via the SPI, then the Watchdog mode selection content is locked and can be changed only via a secured SPI procedure.

7.5.2.1 Window watchdog operation

The window watchdog is available in Normal mode only. The watchdog period selection can be kept (SPI is selectable in INIT mode), while the device enters into LP V_{DD} ON mode. The watchdog period is reset to the default long period after BATFAIL.

The period and the refresh of watchdog are done by the SPI. A refresh must be done in the open window of the period, which starts at 50% of the selected period and ends at the end of the period.

If the watchdog is triggered before 50%, or not triggered before end of period, a reset has occurred. The device enters into Reset mode.

7.5.2.2 Watchdog in debug mode

When the device is in Debug mode (entered via the DBG pin), the watchdog continues to operate but does not affect the device operation by asserting a reset. For the user, operation appears without the watchdog.

When Debug mode is left by software (SPI mode reg), the watchdog period starts at the end of the SPI command.

When Debug mode is left by hardware (DBG pin below 8-10 V), the device enters into Reset mode.

7.5.2.3 Watchdog in flash mode

During Flash mode, watchdog can be set to a long timeout period. Watchdog is timeout only and an $\overline{\text{INT}}$ pulse can be generated at 50% of the time window.

7.5.2.4 Advance watchdog operation

When the Advance watchdog is selected (at INIT mode), the refresh of the watchdog must be done using a random number and with 1, 2, or 4 SPI commands. The number for the SPI command is selected in INIT mode.

The software must read a random byte from the device, and then must return the random byte inverted to clear the watchdog. The random byte write can be performed in 1, 2, or 4 different SPI commands.

If one command is selected, all eight bits are written at once.

If two commands are selected, the first write command must include four of the eight bits of the inverted random byte. The second command must include the next four bits. This completes the watchdog refresh.

If four commands are selected, the first write command must include two of the eight bits of the inverted random byte. The second command must include the next two bits, the 3rd command must include the next two, and the last command, must include the last two. This completes the watchdog refresh. When multiple writes are used, the most significant bits are sent first. The latest SPI command needs to be done inside the open window time frame, if window watchdog is selected.

7.5.3 Detail SPI operation and SPI commands for all watchdog types.

All SPI commands and examples do not use parity functions.

In INIT mode, the watchdog type (window, timeout, advance and number of SPI commands) is selected using the register Init watchdog, bits 1, 2 and 3. The watchdog period is selected using the TIM_A register. The watchdog period selection can also be done in Normal mode or in Normal Request mode.

Transition from INIT mode to Normal mode or from Normal Request mode to Normal mode is done using a single watchdog refresh command (SPI 0x 5A00).

While in Normal mode, the Watchdog Refresh Command depends upon the watchdog type selected in INIT mode. They are detailed in the paragraph below:

7.5.3.1 Simple watchdog

The Refresh command is 0x5A00. It can be send any time within the watchdog period, if the timeout watchdog operation is selected (INIT-watchdog register, bit 1 WD N/Win = 0). It must be send in the open window (second half of the period) if the Window Watchdog operation was selected (INIT-watchdog register, bit 1 WD N/Win = 1).

7.5.3.2 Advance watchdog

The first time the device enters into Normal mode (entry on Normal mode using the 0x5A00 command), Random (RNDM) code must be read using the SPI command, 0x1B00. The device returns on MISO second byte the RNDM code. The full 16 bits MISO is called 0x XXRD. RD is the complement of the RD byte.

7.5.3.3 Advance watchdog, refresh by 1 SPI command

The refresh command is 0x5ARD. During each refresh command, the device will return on MISO, a new Random Code. This new Random Code must be inverted and send along with the next refresh command. It must be done in an open window, if the Window operation was selected.

7.5.3.4 Advance watchdog, refresh by two SPI commands

The refresh command is split in two SPI commands.

The first partial refresh command is 0x5Aw1, and the second is 0x5Aw2. Byte w1 contains the first four inverted bits of the RD byte plus the last four bits equal to zero. Byte w2 contains four bits equal to zero plus the last four inverted bits of the RD byte.

During this second refresh command the device returns on MISO a new Random Code. This new random code must be inverted and send along with the next two refresh commands and so on. The second command must be done in an open window if the Window operation was selected.

7.5.3.5 Advance watchdog, refresh by four SPI commands

The refresh command is split into four SPI commands.

The first partial refresh command is 0x5Aw1, the second is 0x5Aw2, the third is 0x5Aw3, and the last is 0x5Aw4.

Byte w1 contains the first two inverted bits of the RD byte, plus the last six bits equal to zero.

Byte w2 contains two bits equal to zero, plus the next two inverted bits of the RD byte, plus four bits equal to zero.

Byte w3 contains four bits equal to zero, plus the next two inverted bits of the RD byte, plus two bits equal to zero.

Byte w4 contains six bits equal to zero, plus the next two inverted bits of the RD byte.

During this fourth refresh command, the device will return, on MISO, a new Random Code. This new Random Code must be inverted and send along with the next four refresh commands.

The fourth command must be done in an open window if the Window operation was selected.

7.5.4 Proper response to $\overline{\text{INT}}$

During a device detect upon an $\overline{\text{INT}}$, the software handles the $\overline{\text{INT}}$ in a timely manner: Access of the $\overline{\text{INT}}$ register is done within two watchdog periods. This feature must be enabled by SPI using the INIT watchdog register bit 7.

7.6 Functional block operation versus mode

Table 8. Device block operation for each state

State	V _{DD}	5 V-CAN	I/O-X	V _{AUX}	CAN	LIN1/2
Power down	OFF	OFF	OFF	OFF	High-impedance	High-impedance
Init Reset	ON	OFF	HS/LS off Wake-up disable	OFF	OFF: CAN termination 25 k to GND Transmitter / receiver /Wake-up OFF	OFF: internal 30 k pull-up active. Transmitter: receiver / Wake-up OFF. LIN term OFF
INIT	ON	OFF ⁽³⁰⁾	WU disable ⁽³¹⁾⁽³²⁾⁽³³⁾	OFF	OFF	OFF
Reset	ON	Keep SPI config	WU disable ⁽³¹⁾⁽³²⁾⁽³³⁾	OFF	OFF	OFF
Normal Request	ON	Keep SPI config	WU disable ⁽³¹⁾⁽³²⁾⁽³³⁾	OFF	OFF	OFF
Normal	ON	SPI config	SPI config WU SPI config	SPI config	SPI config	SPI config
LP V _{DD} OFF	OFF	OFF	user defined WU SPI config	OFF	OFF + Wake-up en/dis	OFF + Wake-up en/dis
LP V _{DD} ON	ON ⁽²⁹⁾	OFF	user defined WU SPI config	OFF	OFF + Wake-up en/dis	OFF + Wake-up en/dis
SAFE output low: Safe case A	safe case A:ON safe case B: OFF	A: Keep SPI config, B: OFF	HS/LS off Wake-up by change state	OFF	OFF + Wake-up enable	OFF + Wake-up enable
FLASH	ON	SPI config	SPI config	OFF	SPI config	OFF

Notes

29. With limited current capability
30. 5 V-CAN is ON in Debug mode.
31. I/O-0 and I/O-1, configured as an output high-side switch and ON in Normal mode will remain ON in RESET, INIT or Normal Request.
32. I/O-0, configured as an output low-side switch and ON in Normal mode will turn OFF when entering Reset mode, resume operation in Normal mode.
33. I/O-1, configured as an output low-side switch and ON in Normal mode will remain ON in RESET, INIT or Normal Request.

The 5 V-CAN default is ON when the device is powered-up and set in Debug mode. It is fully controllable via the SPI command.

7.7 Illustration of device mode transitions

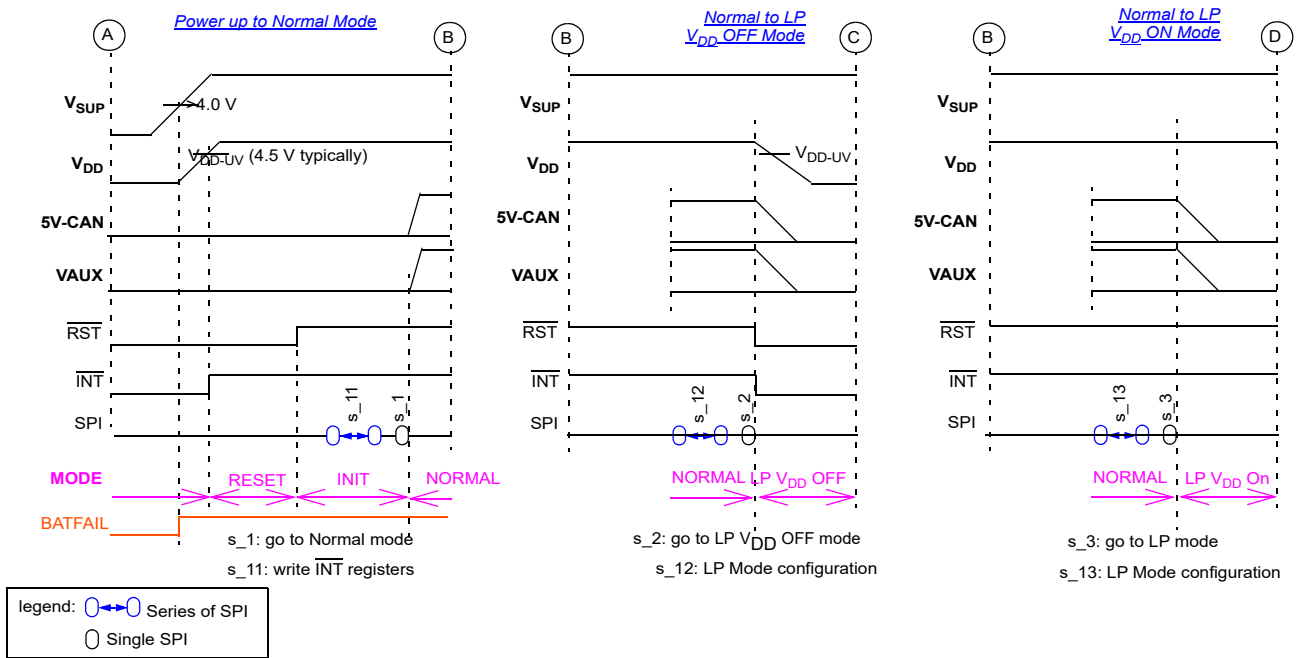

Figure 24. Power up normal and LP modes

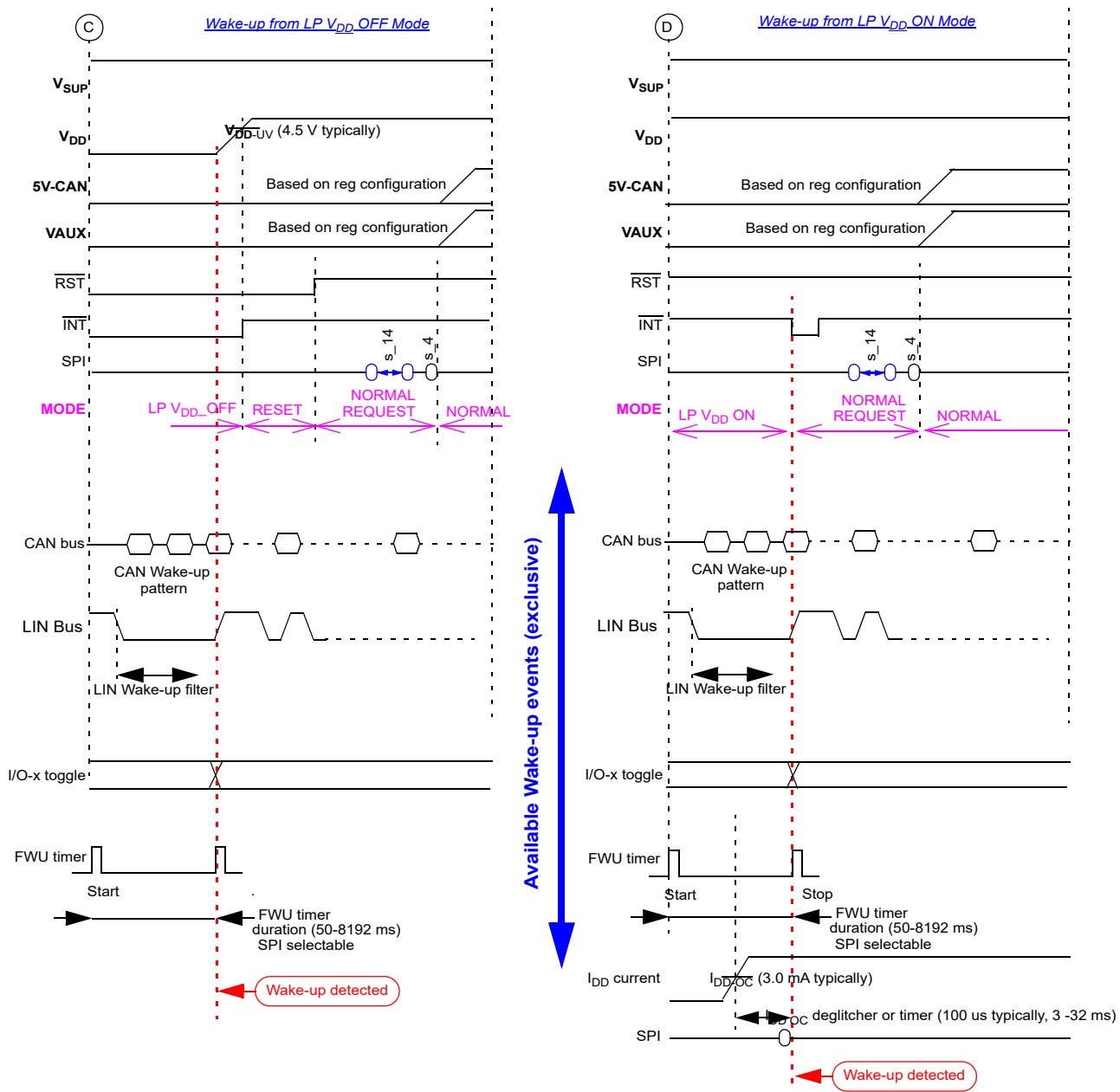

Figure 25. Wake-up from LP modes

7.8 Cyclic sense operation during LP modes

This function can be used in both LP modes: V_{DD} OFF and V_{DD} ON.

Cyclic sense is the periodic activation of I/O-0 to allow biasing of external contact switches. The contact switch state can be detected via I/O-1, -2, and -3, and the device can Wake-up from either LP mode. Cyclic sense is optimized and designed primarily for closed contact switch in order to minimize consumption via the contact pull-up resistor.

7.8.1 Principle

A dedicated timer provides an opportunity to select a cyclic sense period from 3.0 to 512 ms (selection in timer B). At the end of the period, the I/O-0 will be activated for a duration of T_{CSON} (SPI selectable in INIT register, to 200 μ s, 400 μ s, 800 μ s, or 1.6 ms). The I/O-0 HS transistor or LS transistor can be activated. The selection is done by the state of I/O-0 prior to entering in LP mode. During the T_{CSON} duration, the I/O-x's are monitored. If one of them is high, the device will detect a Wake-up. (Figure 26). Cyclic sense period is selected by the SPI configuration prior to entering LP mode. Upon entering LP mode, the I/O-0 should be activated. The level of I/O-1 is sense during the I/O-0 active time, and is deglitched for a duration of typically 30 μ s. This means that I/O-1 should be in the expected state for a duration longer than the deglitch time. The diagram below (Figure 26) illustrates the cyclic sense operation, with I/O-0 HS active and I/O-1 Wake-up at high level.

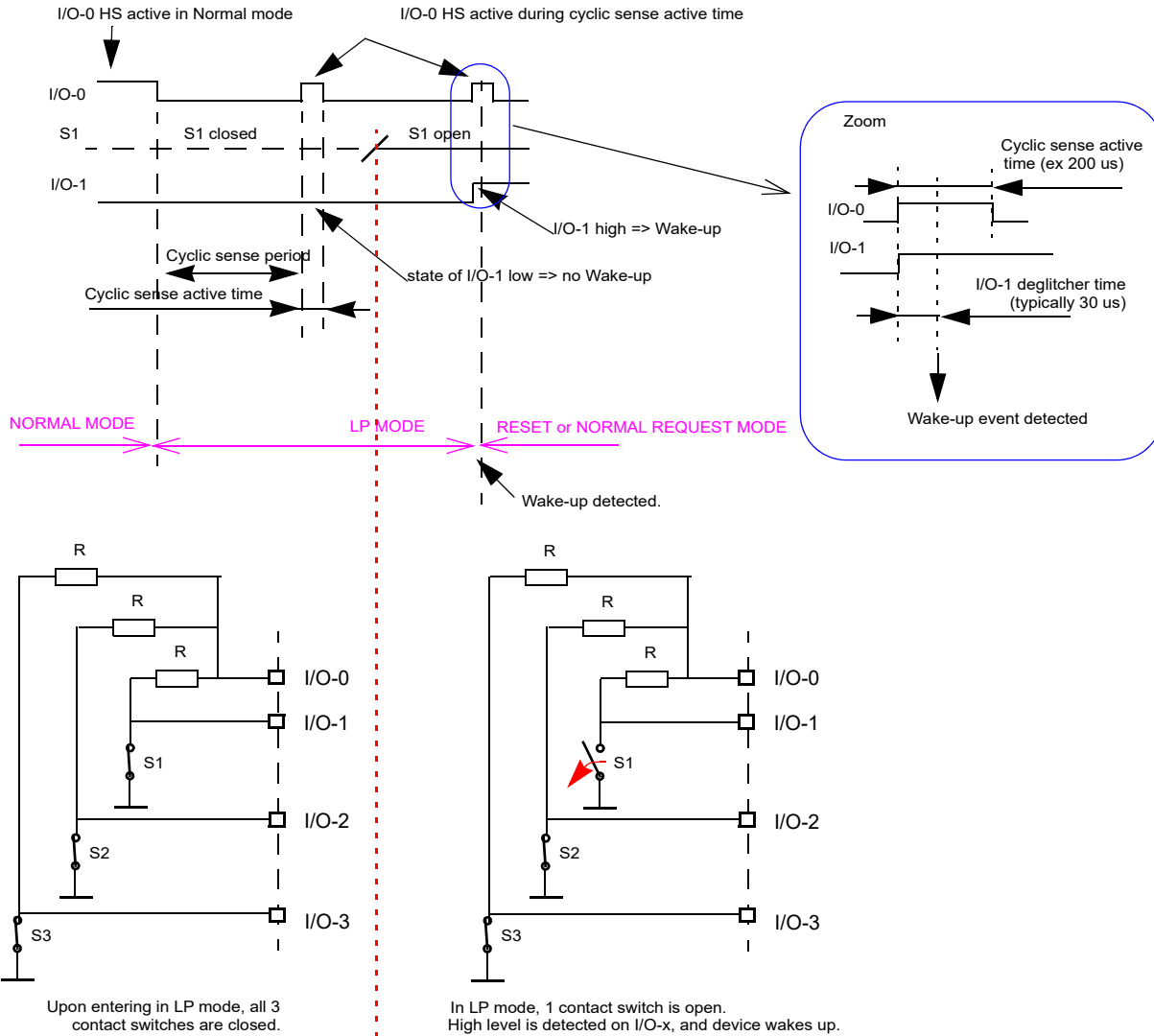

Figure 26. Cyclic sense operation - switch to GND, wake-up by open switch

7.9 Cyclic INT operation during LP VDD on mode

7.9.1 Principle

This function can be used only in LP V_{DD} ON mode (LP V_{DD} ON). When Cyclic INT is selected and device is in LP V_{DD} ON mode, the device will generate a periodic INT pulse.

Upon reception of the INT pulse, the MCU must acknowledge the INT by sending SPI commands before the end of the next INT period in order to keep the process going.

When Cyclic INT is selected and operating, the device remains in LP V_{DD} ON mode, assuming the SPI commands are issued properly. When no/improper SPI commands are sent, the device will cease Cyclic INT operation and leave LP V_{DD} ON mode by issuing a reset. The device will then enter into Normal Request mode. VDD current capability and VDD regulator behavior is similar as in LP V_{DD} ON mode.

7.9.1.1 Operation

Cyclic INT period selection: register timer B

SPI command in hex 0x56xx [example; 0x560E for 512ms cyclic Interrupt period (SPI command without parity bit)].

This command must be send while the device is in Normal mode.

SPI commands to acknowledge INT: (2 commands)

- read the Random code via the watchdog register address using the following command: MOSI 0x1B00 device report on MISO second byte the RNDM code (MISO bit 0-7).

- write watchdog refresh command using the random code inverted: 0x5A RNDb.

These commands can occur at any time within the period.

Initial entry in LP mode with Cyclic INT: after the device is set in LP V_{DD} ON mode, with cyclic INT enable, no SPI command is necessary until the first INT pulse occurs. The acknowledge process must start only after the 1st INT pulse.

Leave LP mode with Cyclic INT:

This is done by a SPI Wake-up command, similar to SPI Wake-up from LP V_{DD} ON mode: 0x5C10. The device will enter into Normal Request mode.

Improper SPI command while Cyclic INT operates:

When no/improper SPI commands are sent, while the device is in LP V_{DD} ON mode with Cyclic INT enable, the device will cease Cyclic INT operation and leave LP V_{DD} ON mode by issuing a reset. The device will then enter into Normal Request mode.

[Figure 27](#) describes the complete Cyclic Interrupt operation.

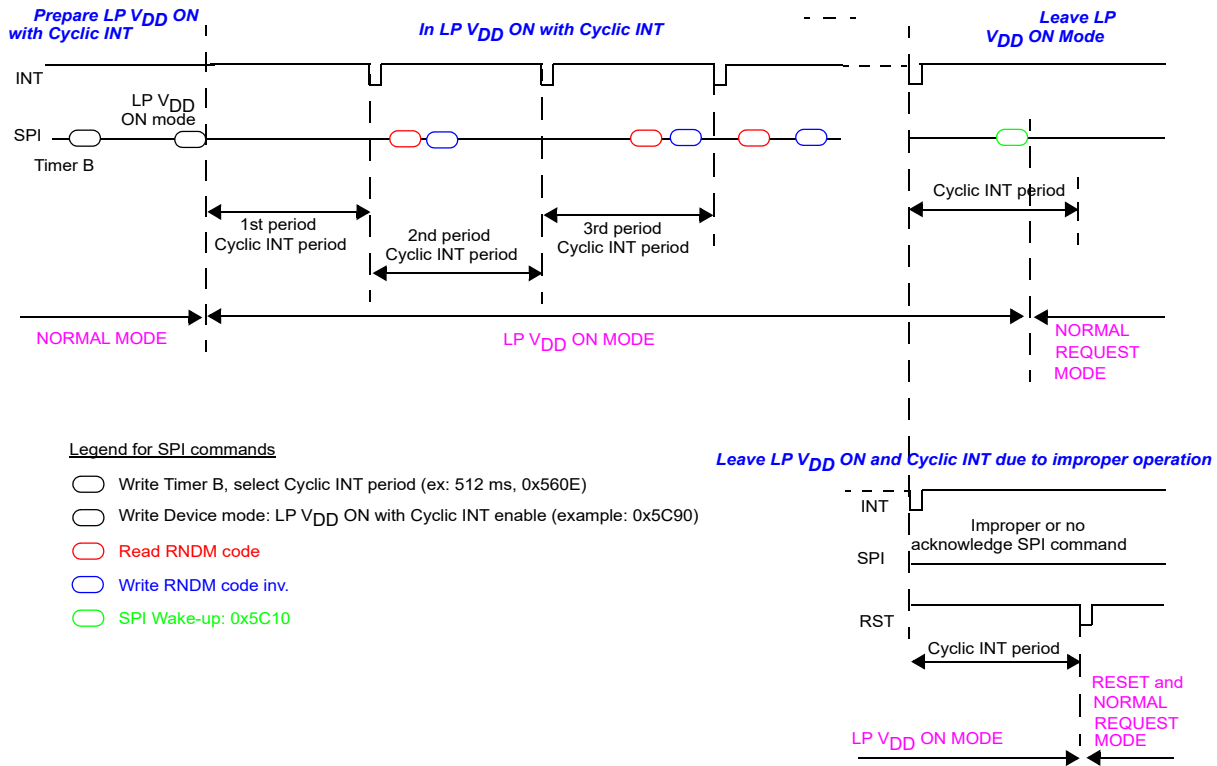

Figure 27. Cyclic interrupt operation

7.10 Behavior at power up and power down

7.10.1 Device power up

This section describe the device behavior during ramp up, and ramp down of V_{SUP/1}, and the flexibility offered mainly by the Crank bit and the two V_{DD} undervoltage reset thresholds.

The figures below illustrate the device behavior during V_{SUP/1} ramp up. As the Crank bit is by default set to 0, V_{DD} is enabled when V_{SUP/1} is above V_{SUP TH 1} parameters.

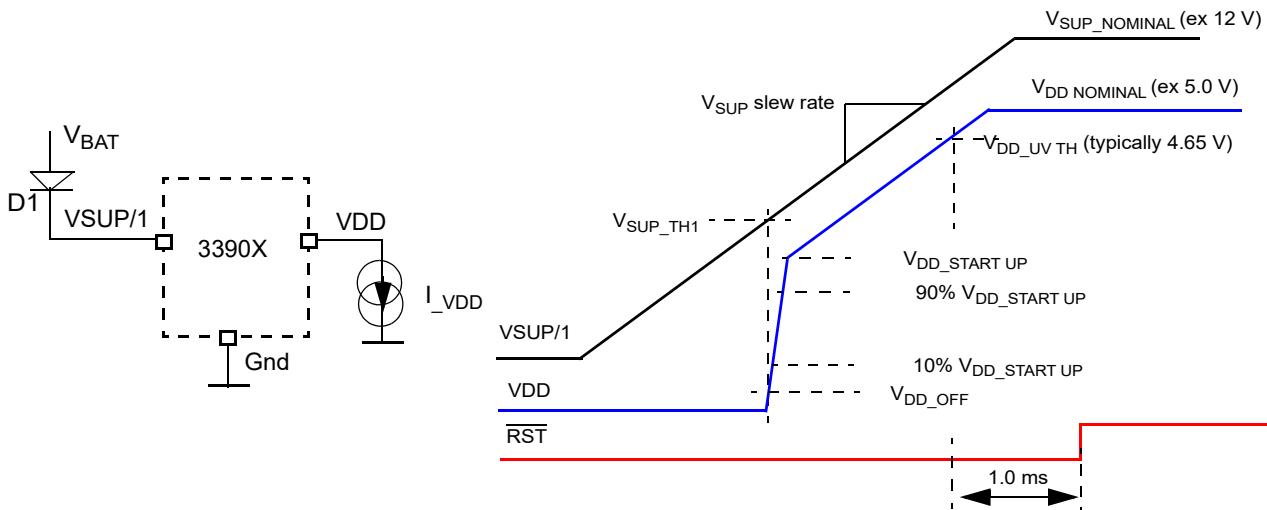

Figure 28. V_{DD} start-up versus $V_{SUP/1}$ tramp

7.10.2 Device power down

The figures below illustrate the device behavior during $V_{SUP/1}$ ramp down, based on Crank bit configuration, and V_{DD} undervoltage reset selection.

7.10.2.1 Crank bit reset (INIT watchdog register, Bit 0 =0)

Bit 0 = 0 is the default state for this bit.

During $V_{SUP/1}$ ramp down, V_{DD} remain ON until device enters in Reset mode due to a V_{DD} undervoltage condition ($V_{DD} < 4.6$ V or $V_{DD} < 3.2$ V typically, threshold selected by the SPI). When device is in Reset, if $V_{SUP/1}$ is below " V_{SUP_TH1} ", V_{DD} is turned OFF.

7.10.2.2 Crank bit set (INIT watchdog register, Bit 0 =1)

The bit 0 is set by SPI write. During $V_{SUP/1}$ ramp down, V_{DD} remains ON until device detects a POR and set BATFAIL. This occurs for a $V_{SUP/1}$ approx 3.0 V.

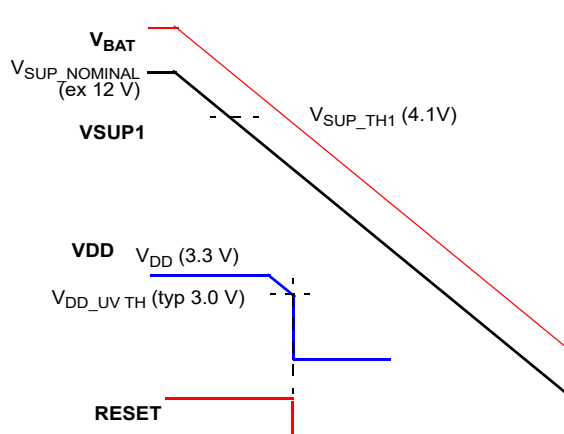

Case 1: V_{DD} 3.3V, " $V_{DD_UV_TH}$ 3.0 V", with bit Crank =0 (default value)

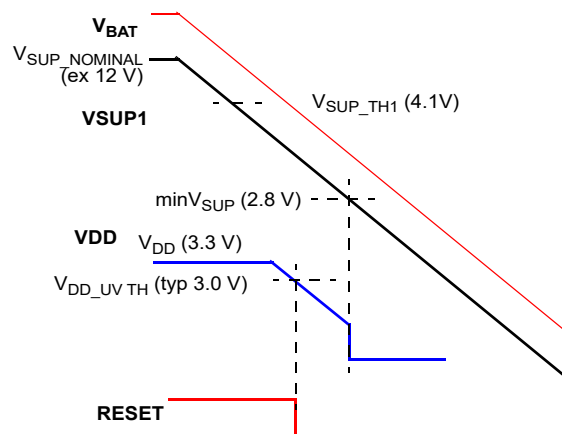

Case 2: V_{DD} 3.3V, " $V_{DD_UV_TH}$ 3.0 V", with bit Crank =1

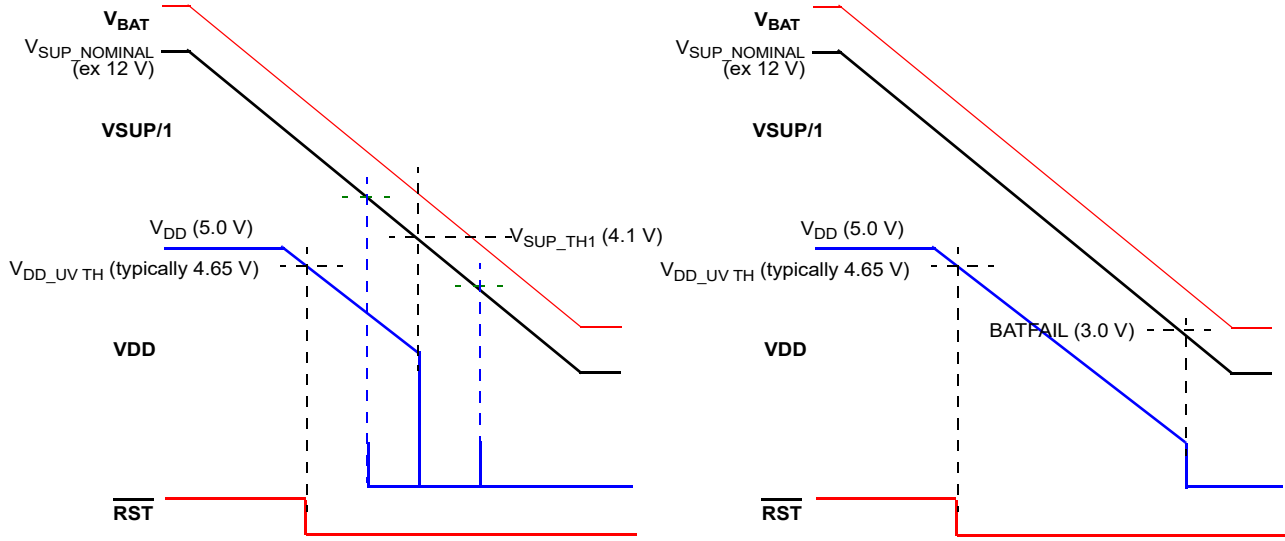

Case 3: “ $V_{DD_UV_TH}$ 4.6V”, with bit Crank = 0 (default value)

Case 4: “ V_{DD_UV} 4.6V”, with bit Crank = 1

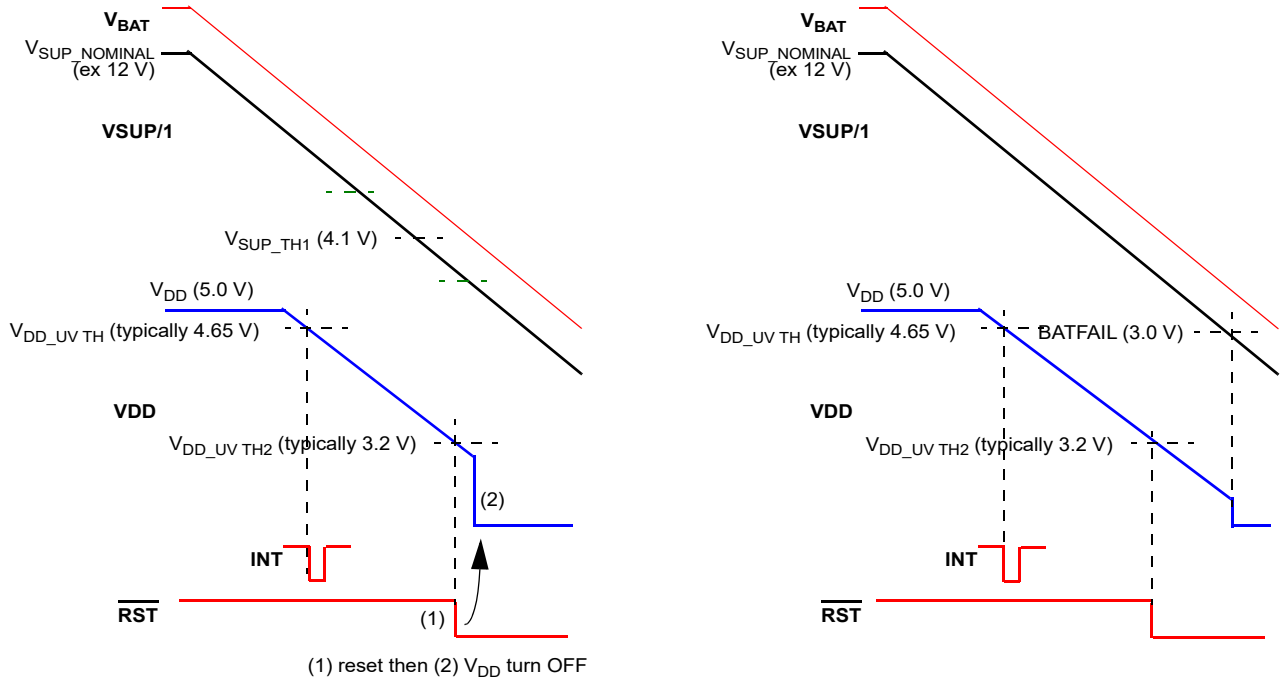

Case 5: “ $V_{DD_UV_TH}$ 3.2V”, with bit Crank = 0 (default value)

Case 6: “ V_{DD_UV} 3.2V”, with bit Crank = 1

Figure 29. V_{DD} behavior during $V_{SUP/1}$ ramp down

7.11 Fail-safe operation

7.11.1 Overview

Fail-safe mode is entered when specific fail conditions occur. The 'Safe state' condition is defined by the resistor connected at the DGB pin. Safe mode is entered after additional event or conditions are met: time out for CAN communication and state at I/O-1 pin.

Exiting the safe state is always possible by a Wake-up event: in the safe state, the device can automatically be awakened by CAN and I/O (if configured as inputs). Upon Wake-up, the device operation is resumed: enter in Reset mode.

7.11.2 Fail-safe functionality

Upon dedicated event or issue detected at a device pin (i.e. $\overline{\text{RST}}$ short to VDD), the Safe mode can be entered. In this mode, the SAFE pin is active low.

7.11.2.1 Description

Upon activation of the SAFE pin, and if the failure condition that make the SAFE pin activated have not recovered, the device can help to reduce ECU consumption, assuming that the MCU is not able to set the whole ECU in LP mode. Two main cases are available:

7.11.2.2 Mode A

Upon SAFE activation, the MCU remains powered (V_{DD} stays ON), until the failure condition recovers (i.e. S/W is able to properly control the device and properly refresh the watchdog).

7.11.2.3 Modes B1, B2 and B3

Upon SAFE activation, the system continues to monitor external event, and disable the MCU supply (turn V_{DD} OFF). The external events monitored are: CAN traffic, I/O-1 low level or both of them. 3 sub cases exist, B1, B2 and B3.

Note: no CAN traffic indicates that the ECU of the vehicle are no longer active, thus that the car is being parked and stopped. The I/O low level detection can also indicate that the vehicle is being shutdown, if the I/O-1 pin is connected for instance to a switched battery signal (ignition key on/off signal).

The selection of the monitored events is done by hardware, via the resistor connected at DBG pin, but can be over written by software, via a specific SPI command.

By default, after power up the device detect the resistor value at DBG pin (upon transition from INIT to Normal mode), and, if no specific SPI command related to Debug resistor change is send, operates according to the detected resistor.

The INIT MISC register allow you to verify and change the device behavior, to either confirm or change the hardware selected behavior. Device will then operate according to the SAFE mode configured by the SPI.

[Table 9](#) illustrates the complete options available:

Table 9. Fail-safe options

Resistor at DBG pin	SPI coding - register INIT MISC bits [2,1,0] (higher priority that Resistor coding)	Safe mode code	V_{DD} status
<6.0 k	bits [2,1,0] = [111]: verification enable: resistor at DBG pin is typically 0 kohm (RA) - Selection of SAFE mode A	A	remains ON
typically 15 k	bits [2,1,0] = [110]: verification enable: resistor at DBG pin is typically 15 kohm (RB1) - Selection of SAFE mode B1	B1	Turn OFF 8.0 s after CAN traffic bus idle detection.
typically 33 k	bits [2,1,0] = [101]: verification enable: resistor at DBG pin is typically 33 kohm (RB2) - Selection of SAFE mode B2	B2	Turn OFF when I/O-1 low level detected.
typically 68 k	bits [2,1,0] = [100]: verification enable: resistor at DBG pin is typically 68 kohm (RB3) - Selection of SAFE mode B3	B3	Turn OFF 8.0 s after CAN traffic bus idle detection AND when I/O-1 low level detected.

7.11.2.4 Exit of safe mode

Exit of the safe state with V_{DD} OFF is always possible by a Wake-up event: in this safe state the device can automatically awakened by CAN and I/O (if I/O Wake-up was enable by the SPI prior to enter into SAFE mode). Upon Wake-up, the device operation is resumed, and device enters in Reset mode. The SAFE pin remains active, until there is a proper read and clear of the SPI flags reporting the SAFE conditions.

SAFE Operation Flow Chart

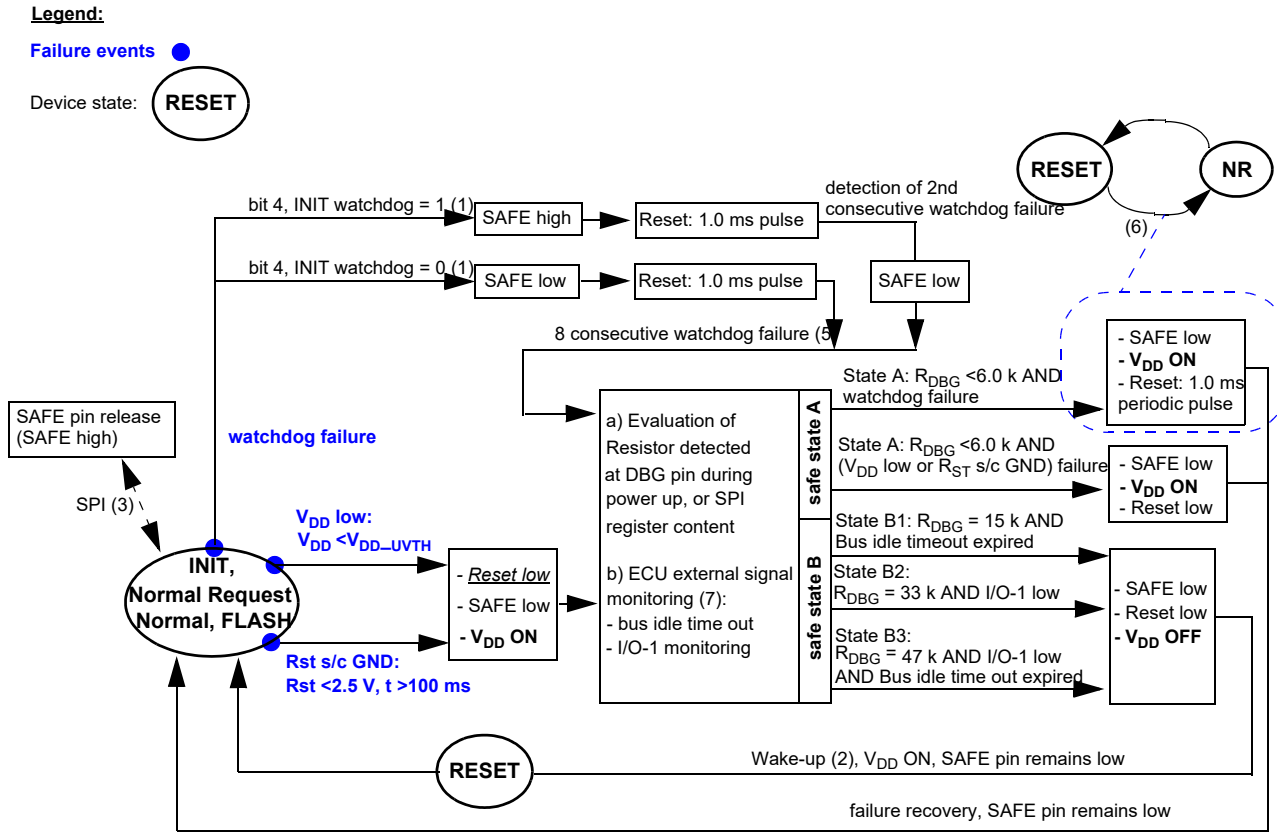

- 1) bit 4 of INIT Watchdog register
- 2) Wake-up event: CAN, LIN or I/O-1 high level (if I/O-1 Wake-up previously enabled)
- 3) SPI commands: 0x1D80 or 0xDD80 to release SAFE pin
- 4) Recovery: reset low condition released, V_{DD} low condition released, correct SPI watchdog refresh
- 5) detection of 8 consecutive watchdog failures: no correct SPI watchdog refresh command occurred for duration of $8 \times 256\text{ ms}$.
- 6) Dynamic behavior: 1.0 ms reset pulse every 256 ms, due to no watchdog refresh SPI command, and device state transition between RESET and NORMAL REQUEST mode, or INIT RESET and INIT modes.
- 7) 8 second timer for bus idle timeout. I/O-1 high to low transition.

Figure 30. Safe operation flow chart

7.11.2.5 Conditions to set SAFE pin active low

Watchdog refresh issue: SAFE activated at 1st reset pulse or at the second consecutive reset pulse (selected by bit 4, INIT watchdog register).

V_{DD} low: $V_{DD} < R_{ST-TH}$. SAFE pin is set low at the same time as the \overline{RST} pin is set low. The \overline{RST} pin is monitored to verify that reset is not clamped to a low level preventing the MCU to operate. If this is the case, the Safe mode is entered.

7.11.2.6 SAFE mode A illustration

Figure 31 illustrates the event and consequences when SAFE mode A is selected via the appropriate debug resistor or SPI configuration.

Behavior Illustration for Safe State A ($R_{DG} < 6.0\text{ kohm}$), or Selection by the SPI

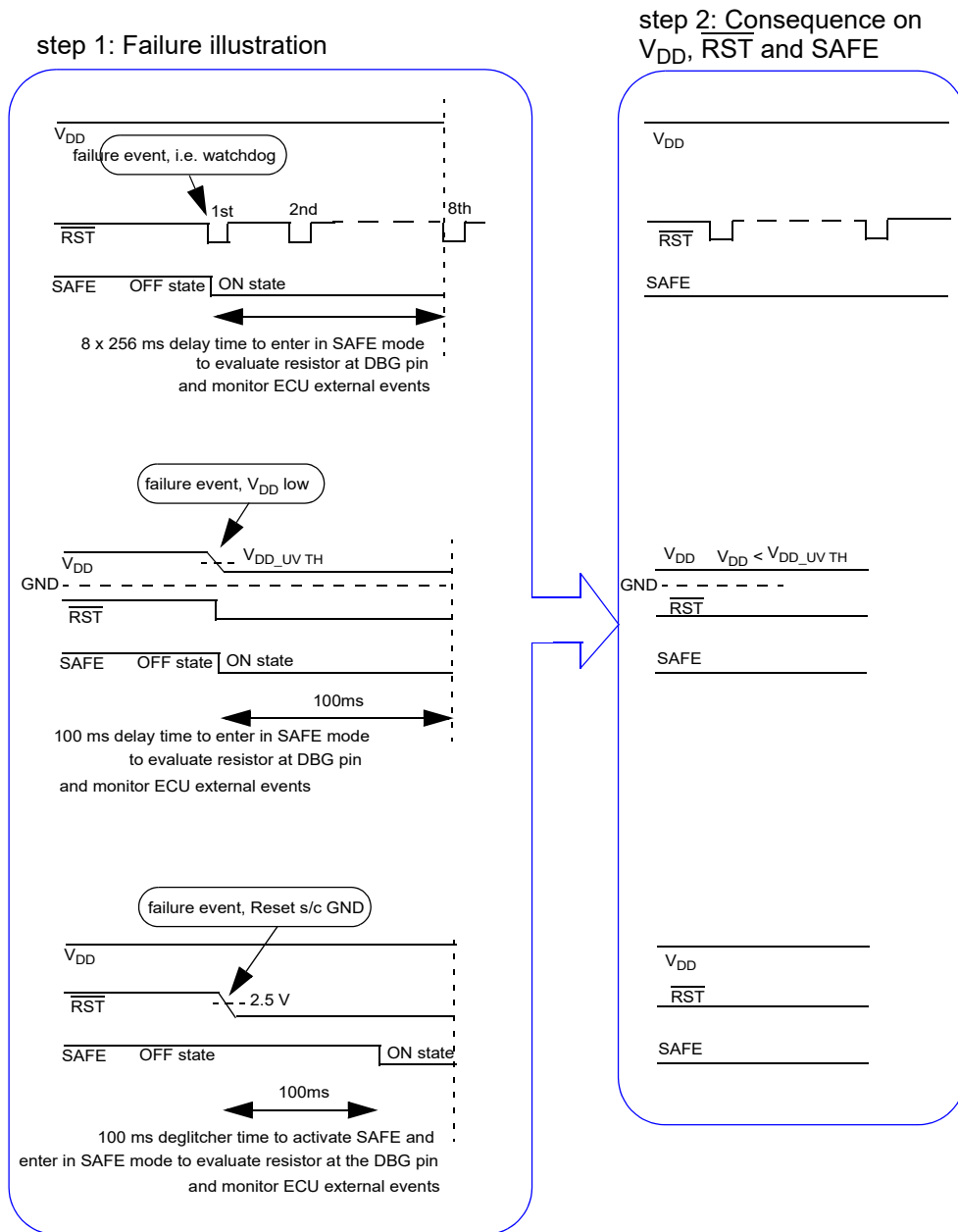

Figure 31. SAFE mode A behavior illustration

7.11.2.7 SAFE mode B1, B2 and B3 illustration

Figure 32 illustrates the event, and consequences when SAFE mode B1, B2, or B3 is selected via the appropriate debug resistor or SPI configuration.

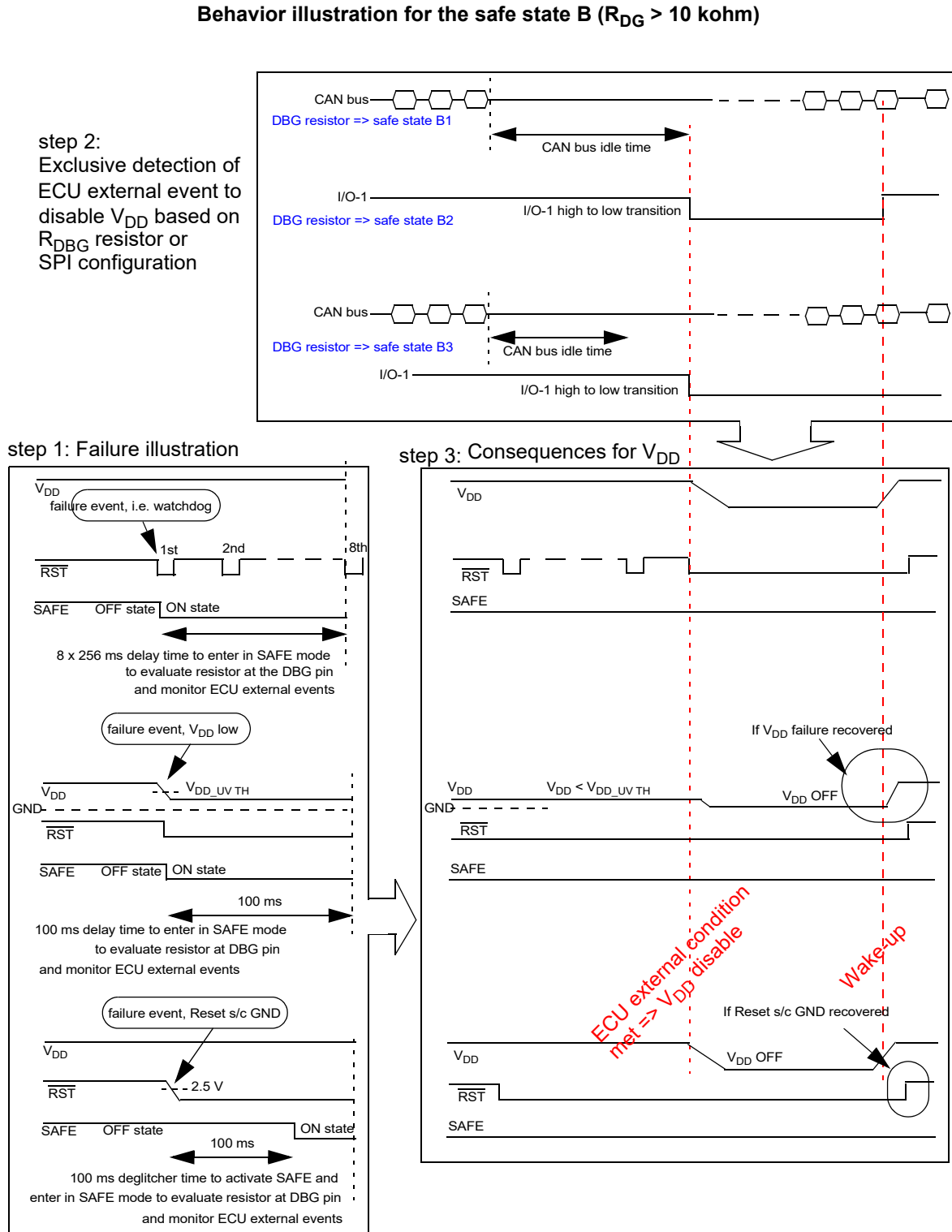

Figure 32. SAFE modes B1, B2, or B3 behavior illustration

8 CAN interface

8.1 CAN interface description

The figure below is a high level schematic of the CAN interface. It exist in a LS driver between CANL and GND, and a HS driver from CANH to 5 V-CAN. Two differential receivers are connected between CANH and CANL to detect a bus state and to Wake-up from CAN Sleep mode. An internal 2.5 V reference provides the 2.5 V recessive levels via the matched R_{IN} resistors. The resistors can be switched to GND in CAN Sleep mode. A dedicated split buffer provides a low-impedance 2.5 V to the SPLIT pin, for recessive level stabilization.

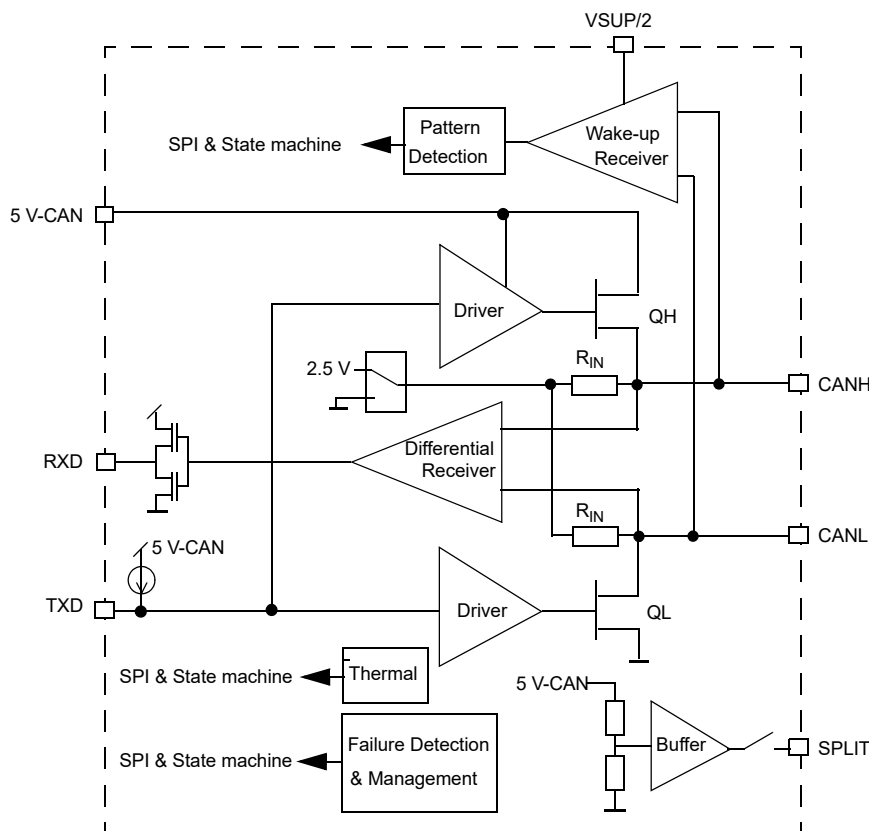

Figure 33. CAN interface block diagram

8.1.1 Can interface supply

The supply voltage for the CAN driver is the 5 V-CAN pin. The CAN interface also has a supply pass from the battery line through the VSUP/2 pin. This pass is used in CAN Sleep mode to allow Wake-up detection.

During CAN communication (transmission and reception), the CAN interface current is sourced from the 5 V-CAN pin. During CAN LP mode, the current is sourced from the VSUP/2 pin.

8.1.2 TXD/RXD mode

In TXD/RXD mode, both the CAN driver and the receiver are ON. In this mode, the CAN lines are controlled by the TXD pin level and the CAN bus state is reported on the RXD pin.

The 5 V-CAN regulator must be ON. It supplies the CAN driver and receiver. The SPLIT pin is active and a 2.5 V biasing is provided on the SPLIT output pin.

8.1.2.1 Receive only mode

This mode is used to disable the CAN driver, but leave the CAN receiver active. In this mode, the device is only able to report the CAN state on the RXD pin. The TXD pin has no effect on CAN bus lines. The 5 V-CAN regulator must be ON. The SPLIT pin is active and a 2.5 V biasing is provided on the SPLIT output pin.

8.1.2.2 Operation in TXD/RXD mode

The CAN driver will be enabled as soon as the device is in Normal mode and the TXD pin is recessive.

When the CAN interface is in Normal mode, the driver has two states: recessive or dominant. The driver state is controlled by the TXD pin. The bus state is reported through the RXD pin.

When TXD is high, the driver is set in the recessive state, and CANH and CANL lines are biased to the voltage set with 5 V-CAN divided by 2, or approx. 2.5 V.

When TXD is low, the bus is set into the dominant state, and CANL and CANH drivers are active. CANL is pulled low and CANH is pulled high.

The RXD pin reports the bus state: CANH minus the CANL voltage is compared versus an internal threshold (a few hundred mV).

If "CANH minus CANL" is below the threshold, the bus is recessive and RXD is set high.

If "CANH minus CANL" is above the threshold, the bus is dominant and RXD is set low.

The SPLIT pin is active and provides a 2.5 V biasing to the SPLIT output.

8.1.2.3 TXD/RXD mode and slew rate selection

The CAN signal slew rate selection is done via the SPI. By default and if no SPI is used, the device is in the fastest slew rate. Three slew rates are available. The slew rate controls the recessive to dominant, and dominant to recessive transitions. This also affects the delay time from the TXD pin to the bus and from the bus to the RXD. The loop time is thus affected by the slew rate selection.

8.1.2.4 Minimum baud rate

The minimum baud rate is determined by the shortest TXD permanent dominant timing detection. The maximum number of consecutive dominant bits in a frame is 12 (6 bits of active error flag and its echo error flag).

The shortest TXD dominant detection time of 300 μ s lead to a single bit time of: $300 \mu\text{s} / 12 = 25 \mu\text{s}$.

So the minimum Baud rate is $1 / 25 \mu\text{s} = 40 \text{ kBaud}$.

8.1.2.5 Sleep mode

Sleep mode is a reduced current consumption mode. CANH and CANL drivers are disabled and CANH and CANL lines are terminated to GND via the R_{IN} resistor, the SPLIT pin is high-impedance. In order to monitor bus activities, the CAN Wake-up receiver can be enabled. It is supplied internally from $V_{SUP/2}$.

Wake-up events occurring on the CAN bus pin are reporting by dedicated flags in SPI and by \overline{INT} pulse, and results in a device Wake-up if the device was in LP mode. When the device is set back into Normal mode, CANH and CANL are set back into the recessive level. This is illustrated in [Figure 34](#).

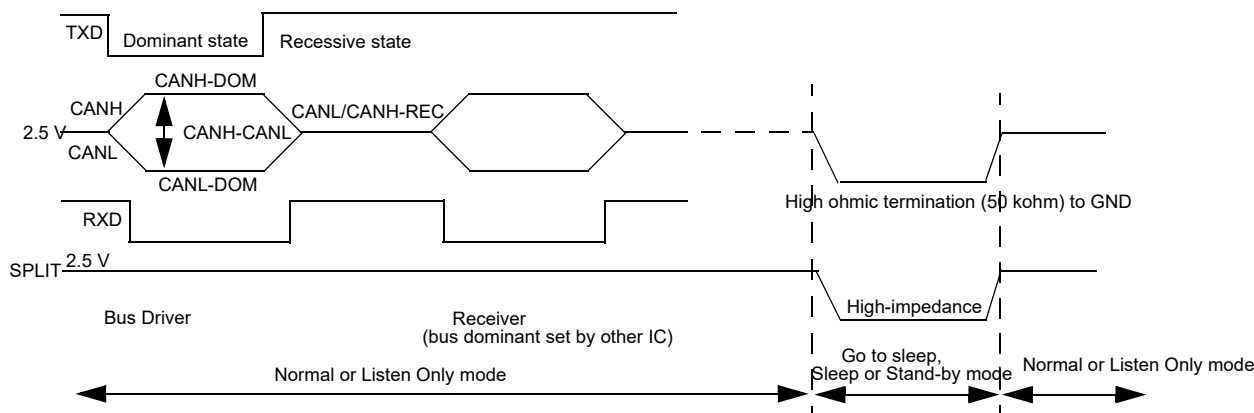

Figure 34. Bus signal in TXD/RXD and LP mode

8.1.2.6 Wake-up

When the CAN interface is in Sleep mode with Wake-up enabled, the CAN bus traffic is detected. The CAN bus Wake-up is a pattern Wake-up. The Wake-up by the CAN is enabled or disabled via the SPI.

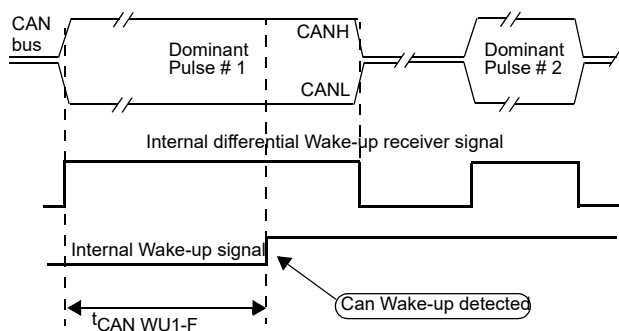

Figure 35. Single dominant pulse wake-up

8.1.2.7 Pattern wake-up

In order to Wake-up the CAN interface, the Wake-up receiver must receive a series of three consecutive valid dominant pulses, by default when the CANWU bit is low. CANWU bit can be set high by SPI and the Wake-up will occur after a single pulse duration of 2.0 μs (typically). A valid dominant pulse should be longer than 500 ns. The three pulses should occur in a time frame of 120 μs , to be considered valid. When three pulses meet these conditions, the wake signal is detected. This is illustrated by the following figure.

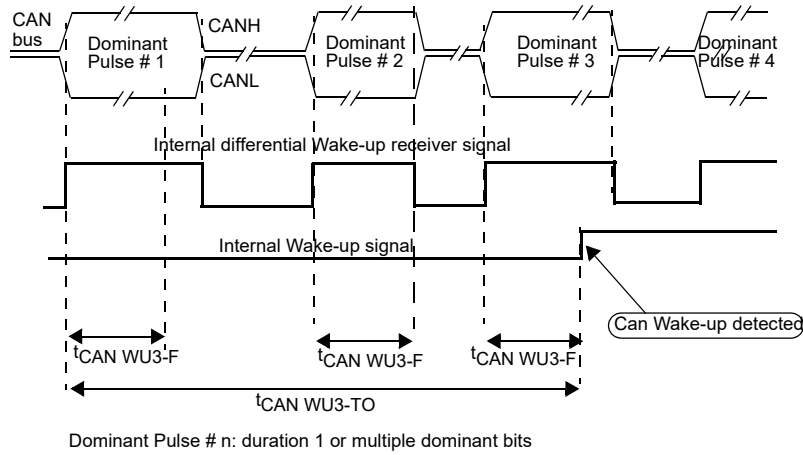

Figure 36. Pattern wake-up - multiple dominant detection

8.1.3 BUS termination

The device supports the two main types of bus terminations:

- Differential termination resistors between CANH and CANL lines.
- SPLIT termination concept, with the mid point of the differential termination connected to GND through a capacitor and to the SPLIT pin.
- In application, the device can also be used without termination.
- [Figure 37](#) illustrates some of the most common terminations.

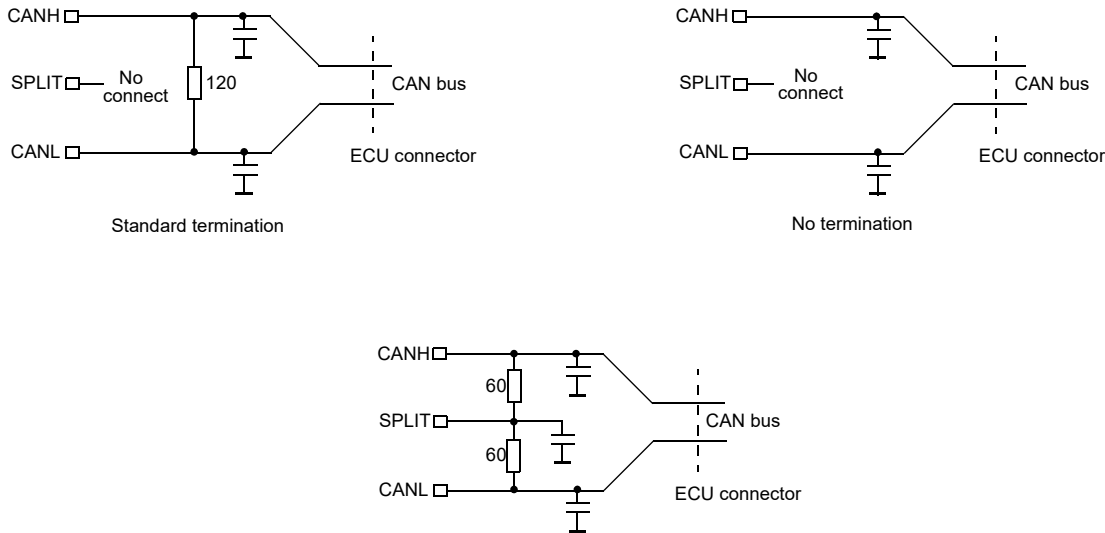

Figure 37. Bus termination options

8.2 CAN bus fault diagnostic

The device includes diagnostic of bus short-circuit to GND, VBAT, and internal ECU 5.0 V. Several comparators are implemented on CANH and CANL lines. These comparators monitor the bus level in the recessive and dominant states. The information is then managed by a logic circuitry to properly determine the failure and report it.

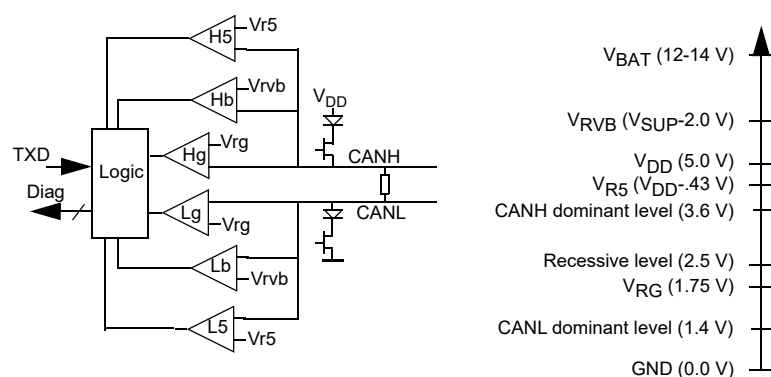

Figure 38. CAN bus simplified structure truth table for failure detection

The following table indicates the state of the comparators when there is a bus failure, and depending upon the driver state.

Table 10. Failure detection truth table

Failure description	Driver recessive state		Driver dominant state	
	Lg (threshold 1.75 V)	Hg (threshold 1.75 V)	Lg (threshold 1.75 V)	Hg (threshold 1.75 V)
No failure	1	1	0	1
CANL to GND	0	0	0	1
CANH to GND	0	0	0	0
	Lb (threshold $V_{SUP} - 2.0$ V)	Hb (threshold $V_{SUP} - 2.0$ V)	Lb (threshold $V_{SUP} - 2.0$ V)	Hb (threshold $V_{SUP} - 2.0$ V)
No failure	0	0	0	0
CANL to VBAT	1	1	1	1
CANH to VBAT	1	1	0	1
	L5 (threshold $V_{DD} - 0.43$ V)	H5 (threshold $V_{DD} - 0.43$ V)	L5 (threshold $V_{DD} - 0.43$ V)	H5 (threshold $V_{DD} - 0.43$ V)
No failure	0	0	0	0
CANL to 5.0 V	1	1	1	1
CANH to 5.0 V	1	1	0	1

8.2.1 Detection principle

In the recessive state, if one of the two bus lines are shorted to GND, VDD (5.0 V), or VBAT, the voltage at the other line follows the shorted line, due to the bus termination resistance. For example: if CANL is shorted to GND, the CANL voltage is zero, the CANH voltage measured by the Hg comparator is also close to zero.

In the recessive state, the failure detection to GND or VBAT is possible. However, it is not possible with the above implementation to distinguish which of the CANL or CANH lines are shorted to GND or VBAT. A complete diagnostic is possible once the driver is turned on, and in the dominant state.

8.2.1.1 Number of samples for proper failure detection

The failure detector requires at least one cycle of the recessive and dominant states to properly recognize the bus failure. The error will be fully detected after five cycles of the recessive-dominant states. As long as the failure detection circuitry has not detected the same error for five recessive-dominant cycles, the error is not reported.

8.2.2 Bus clamping detection

If the bus is detected to be in dominant for a time longer than (T_{DOM}), the bus failure flag is set and the error is reported in the SPI.

This condition could occur when the CANH line is shorted to a high-voltage. In this case, current will flow from the high-voltage short-circuit, through the bus termination resistors (60 Ω), into the SPLIT pin (if used), and into the device CANH and CANL input resistors, which are terminated to internal 2.5 V biasing or to GND (Sleep mode).

Depending upon the high-voltage short-circuit, the number of nodes, usage of the SPLIT pin, R_{IN} actual resistor and mode state (Sleep or Active) the voltage across the bus termination can be sufficient to create a positive dominant voltage between CANH and CANL, and the RXD pin will be low. This would prevent start of any CAN communication and thus, proper failure identification requires five pulses on TXD. The bus dominant clamp circuit will help to determine such failure situation.

8.2.3 RXD permanent recessive failure (does not apply to ‘C’ and ‘D’ versions)

The aim of this detection is to diagnose an external hardware failure at the RXD output pin and ensure that a permanent failure at RXD does not disturb the network communication. If RXD is shorted to a logic high signal, the CAN protocol module within the MCU will not recognize any incoming message. In addition, it will not be able to easily distinguish the bus idle state and can start communication at any time. In order to prevent this, RXD failure detection is necessary. When a failure is detected, the RXD high flag is set and CAN switches to receive only mode.

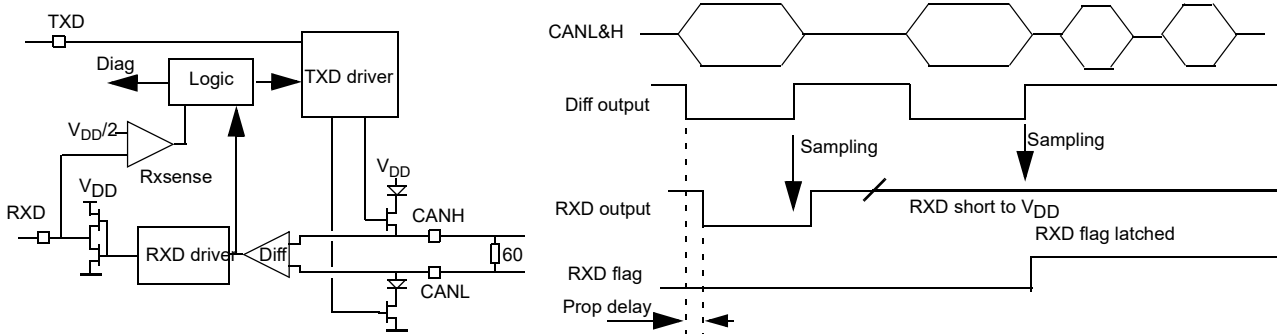

The RXD flag is not the RXPR bit in the LPC register, and neither is the CANF in the INTR register.

Figure 39. RXD path simplified schematic, RXD short to V_{DD} detection

8.2.3.1 Implementation for detection

The implementation senses the RXD output voltage at each low to high transition of the differential receiver. Excluding the internal propagation delay, the RXD output should be low when the differential receiver is low. When an external short to V_{DD} at the RXD output, RXD will be tied to a high level and can be detected at the next low to high transition of the differential receiver.

As soon as the RXD permanent recessive is detected, the RXD driver is deactivated.

Once the error is detected the driver is disabled and the error is reported via SPI in CAN register.

8.2.3.2 Recovery condition

The internal recovery is done by sampling a correct low level at TXD as shown in the following illustration.

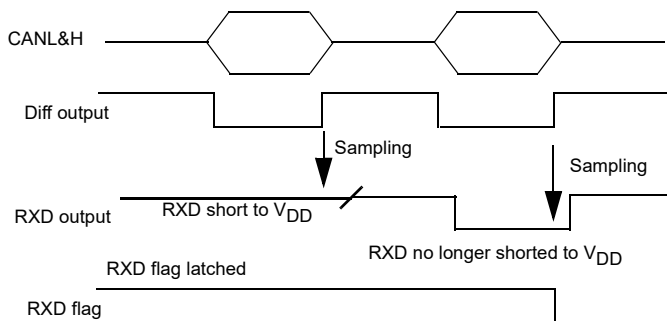

The RXD flag is not the RXPR bit in the LPC register, and neither is the CANF in the INTR register.

Figure 40. RXD path simplified schematic, RXD short to V_{DD} detection

8.2.4 TXD permanent dominant

8.2.4.1 Principle

If the TXD is set to a permanent low level, the CAN bus is set into dominant level, and no communication is possible. The device has a TXD permanent timeout detector. After the timeout (T_{DOUT}), the bus driver is disabled and the bus is released into a recessive state. The TXD permanent flag is set.

8.2.4.2 Recovery

The TXD permanent dominant is used and activated when there is a TXD short to RXD. The recovery condition for a TXD permanent dominant (recovery means the re-activation of the CAN drivers) is done by entering into a Normal mode controlled by the MCU or when TXD is recessive while RXD change from recessive to dominant.

8.2.5 TXD to RXD short-circuit

8.2.5.1 Principle

When TXD is shorted to RXD during incoming dominant information, RXD is set to low. Consequently, the TXD pin is low and drives CANH and CANL into a dominant state. Thus the bus is stuck in dominant. No further communication is possible.

8.2.5.2 Detection and recovery

The TXD permanent dominant timeout will be activated and release the CANL and CANH drivers. However, at the next incoming dominant bit, the bus will then be stuck in dominant again. The recovery condition is same as the TXD dominant failure

8.2.6 Important information for bus driver reactivation

The driver stays disabled until the failure is/are removed (TXD and/or RXD is no longer permanent dominant or recessive state or shorted) and the failure flags cleared (read). The CAN driver must be set by SPI in TXD/RXD mode in order to re enable the CAN bus driver.

9 LIN block

9.1 LIN interface description

The physical interface is dedicated to automotive LIN sub-bus applications.

The interface has 20 kbps and 10 kbps baud rates, and includes as well as a fast baud rate for test and programming modes. It has excellent ESD robustness and immunity against disturbance, and radiated emission performance. It has safe behavior when a LIN bus short-to-ground, or a LIN bus leakage during LP mode. Digital inputs are related to the device VDD pin.

9.1.1 Power supply pin (VSUP/2)

The VSUP/2 pin is the supply pin for the LIN interface. To avoid a false bus message, an undervoltage on VSUP/2 disables the transmission path (from TXD to LIN) when

$V_{SUP/2}$ falls below 6.1 V.

9.1.2 Ground pin (GND)

When there is a ground disconnection at the module level, the LIN interface do not have significant current consumption on the LIN bus pin when in the recessive state.

9.1.3 LIN bus pin (LIN, lin1, lin2)

The LIN pin represents the single-wire bus transmitter and receiver. It is suited for automotive bus systems, and is compliant to the LIN bus specification 2.1 and SAEJ2602-2. The LIN interface is only active during Normal mode.

9.1.3.1 Driver characteristics

The LIN driver is a LS MOSFET with internal overcurrent thermal shutdown. An internal pull-up resistor with a serial diode structure is integrated so no external pull-up components are required for the application in a slave node. An additional pull-up resistor of 1.0 k Ω must be added when the device is used in the master node. The 1.0 k Ω pull-up resistor can be connected to the LIN pin or to the ECU battery supply.

The LIN pin exhibits no reverse current from the LIN bus line to VSUP/2, even in the event of a GND shift or VSUP/2 disconnection. The transmitter has a 20 kbps, 10 kbps and fast baud rate, which are selected by SPI.

9.1.3.2 Receiver characteristics

The receiver thresholds are ratiometric with the device $V_{SUP/2}$ voltage.

If the $V_{SUP/2}$ voltage goes below typically 6.1 V, the LIN bus enters into a recessive state even if communication is sent on TXD.

If LIN driver temperature reaches the overtemperature threshold, the transceiver and receiver are disabled. When the temperature falls below the overtemperature threshold, LIN driver and receiver will be automatically enabled.

9.1.4 Data input pin (TXD-L, TXD-L1, TXD-L2)

The TXD-L, TXD-L1 and TXD-L2 input pin is the MCU interface to control the state of the LIN output. When TXD-L is LOW (dominant), LIN output is LOW. When TXD-L is HIGH (recessive), the LIN output transistor is turned OFF.

This pin has an internal pull-up current source to V_{DD} to force the recessive state if the input pin is left floating.

If the pin stays low (dominant state) more than t_{TXDDOM} , the LIN transmitter goes automatically in recessive state. This is reported by flag in LIN register.

9.1.5 Data output pin (RXD-L, RXD-L1, RXD-L2)

This output pin is the MCU interface, which reports the state of the LIN bus voltage. LIN HIGH (recessive) is reported by a high voltage on RXD, LIN LOW (dominant) is reported by a low voltage on RXD.

9.2 LIN operational modes

The LIN interface have two operational modes, Transmit receiver and LIN disable modes.

9.2.1 Transmit receive

In the TXD/RXD mode, the LIN bus can transmit and receive information.

When the 20 kbps baud rate is selected, the slew rate and timing are compatible with LIN protocol specification 2.1.

When the 10 kbps baud rate is selected, the slew rate and timing are compatible with J2602-2.

When the fast baud rate is selected, the slew rate and timing are much faster than the above specification and allow fast data transition. The LIN interface can be set by the SPI command in TXD/RXD mode, only when TXD-L is at a high level. When the SPI command is send while TXD-L is low, the command is ignored.

9.2.2 Sleep mode

This mode is selected by SPI, and the transmission path is disabled. Supply current for LIN block from $V_{SUP/2}$ is very low (typically 3.0 μ A). LIN bus is monitor to detect Wake-up event. In the Sleep mode, the internal 725 kOhm pull-up resistor is connected and the 30 kOhm disconnected. The LIN block can be awakened from Sleep mode by detection of LIN bus activity.

9.2.2.1 LIN bus activity detection

The LIN bus Wake-up is recognized by a recessive to dominant transition, followed by a dominant level with a duration greater than 70 μ s, followed by a dominant to recessive transition. This is illustrated in [Figures 20](#) and [21](#). Once the Wake-up is detected, the event is reported to the device state machine. An INT is generated if the device is in LP V_{DD} ON mode, or V_{DD} will restart if the device was in LP V_{DD} OFF mode. The Wake-up can be enable or disable by the SPI.

Fail-safe Features

[Table 11](#) describes the LIN block behavior when there is a failure.

Table 11. LIN block failure

Fault	Functionnal mode	Condition	Consequence	Recovery
LIN supply Undervoltage	TXD RXD	LIN supply voltage < 6.0 V (typically)	LIN transmitter in recessive State	Condition gone
TXD Pin Permanent Dominant		TXD pin low for more than t_{TXDDOM}	LIN transmitter in recessive State	Condition gone
LIN Thermal Shutdown	TXD RXD	LIN driver temperature > 160 °C (typically)	LIN transmitter and receiver disabled HS turned off	Condition gone

10 Serial peripheral interface

10.1 High level overview

The device uses a 16 bits SPI, with the following arrangements:

MOSI, Master Out Slave In bits:

- bits 15 and 14 (called C1 and C0) are control bits to select the SPI operation mode (write control bit to device register, read back of the control bits, read of device flag).
- bit 13 to 9 (A4 to A0) to select the register address.
- bit 8 (P/N) has two functions: parity bit in write mode (optional, = 0 if not used), Next bit (= 1) in read mode.
- bit 7 to 0 (D7 to D0): control bits

MISO, Master In Slave Out bits:

- bits 15 to 8 (S15 to S8) are device status bits
- bits 7 to 0 (Do7 to Do0) are either extended device status bits, device internal control register content or device flags.

The SPI implementation does not support daisy chain capability.

[Figure 41](#) is an overview of the SPI implementation.

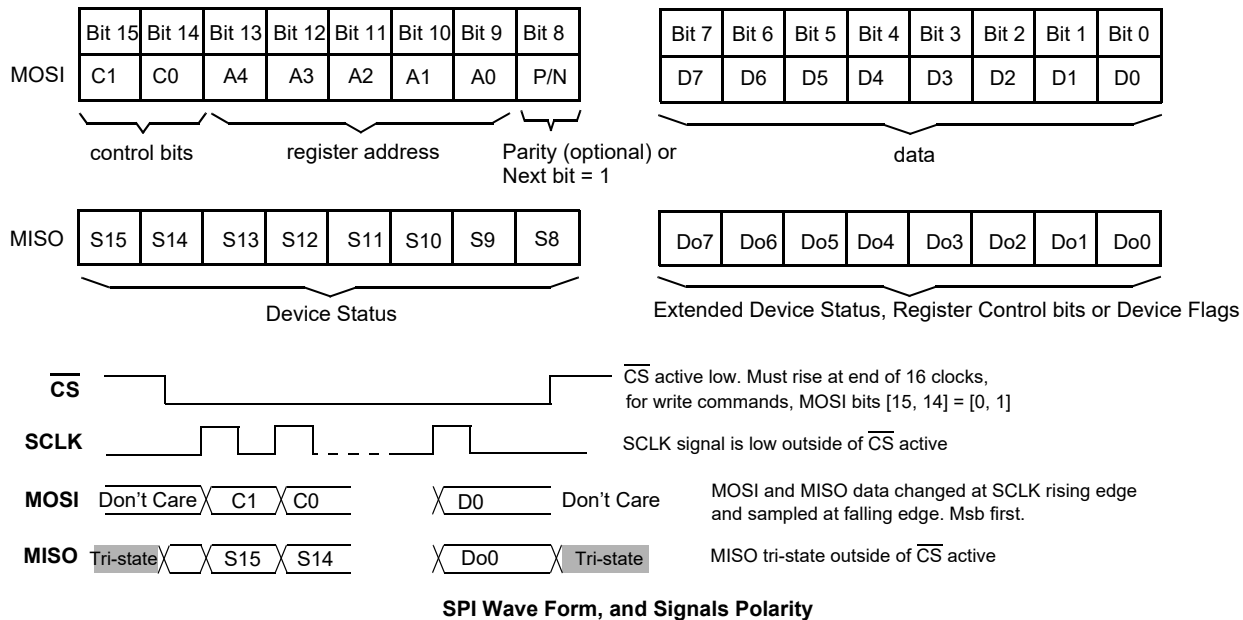

Figure 41. SPI overview

10.2 Detail operation

The SPI operation deviation (does not apply to 'C' and 'D' versions).

In some cases, the SPI write command is not properly interpreted by the device. This results in either a 'non received SPI command' or a 'corrupted SPI command'. **Important:** Due to this, the t_{LEAD} and t_{CSLOW} parameters must be carefully acknowledged.

Only SPI **write** commands (starting with bits 15,14 = 01) are affected. The SPI **read** commands (starting with bits 15,14 = 00 or 11) are not affected.

The occurrence of this issue is extremely low and is caused by the synchronization between internal and external signals. In order to guarantee proper operation, the following steps must be taken.

1. Ensure the duration of the **Chip Select Low (t_{CSLOW}) state is >5.5 μ s.**

Note: In data sheet revisions prior to 7.0, this parameter is not specified and is indirectly defined by the sum of 3 parameters, $t_{LEAD} + 16 \times t_{PCLK} + t_{LAG}$ (sum = 4.06 μ s).

2. Ensure SPI timing parameter t_{LEAD} is a min. of 550 ns.

Note: In data sheet revisions prior to 7.0, the t_{LEAD} parameter is a min of 30 ns.

3. Make sure to **include a SPI read command after a SPI write command.**

In case a series of SPI write commands is used, only one additional SPI read is necessary. The recommended SPI read command is “device ID read: 0x2580” so device operation is not affected (ex: clear flag). Other SPI **read** commands may also be used.

When the previous steps are implemented, the device will operate as follows:

For a given SPI write command (named SPI write ‘n’):

- In case the SPI write command ‘n’ is not accepted, the following SPI command (named SPI ‘n+1’) will finish the write process of the SPI write ‘n’, thanks to step 2 ($t_{LAG} > 550$ ns) and step 3 (which is the additional SPI command ‘n+1’).
- By applying steps 1, 2, and 3, no SPI command is ignored. Worst case, the SPI write ‘n’ is executed at the time the SPI ‘n+1’ is sent. This will lead to a delay in device operation (delay between SPI command ‘n’ and ‘n+1’).

Note: Occurrence of an incorrect command is reduced, thanks to step 1 (extension of t_{CSLOW} duration to >5.5 μ s).

Sequence examples:

Example 1:

- 0x60C0 (CAN interface control) – in case this command is missed, next write command will complete it
- 0x66C0 (LIN interface control) – in case this command is missed, next read command will complete it
- 0x2580 (read device ID) – Additional command to complete previous LIN command, in case it was missed

Example 2:

- 0x60C0 (CAN interface control) - in case this command is missed, next write command will complete it
- 0x66C0 (LIN interface control) - in case this command is missed, next read command will complete it
- 0x2100 (read CAN register content) – this command will complete previous one, in case it was missed
- 0x2700 (read LIN register content)

SPI Operation if the CSB low flag is set to '1' (All product versions)

When the ‘CSB low’ flag is set (Bit 4 = ‘1’ using the 0xE300 SPI command), the next SPI write commands are executed by the device only if the SPI t_{LEAD} time is between 30 ns and 2.5 μ s maximum for the ‘C’ and ‘D’ versions, and 550 ns and 2.5 μ s maximum for others versions.

The occurrence of the CSB flag set to ‘1’ is extremely low and is directly linked to an intermittent short to ground on the board trace or a CSB driven low by the MCU. In both cases, the CSB pin must be asserted low for more than 2.0 ms to set the flag.

The t_{LEAD} time is represented in the SPI timing diagram ([Figure 14](#)) and corresponds to the time between CSB high to low transition and first SCLK signal.

Note:

If the flag is cleared by a read command and the fault is no longer present, the 2.5 μ s maximum of t_{LEAD} time does not apply, but can also be respected. This means if all the SPI write commands use a maximum t_{LEAD} time of 2.5 μ s, they are all interpreted by the device, whatever the indication of the ‘CSB low’ flag.

10.2.1 Bits 15, 14, and 8 functions

[Table 12](#) summarizes the various SPI operation, depending upon bit 15, 14, and 8.

Table 12. SPI operations (bits 8, 14, & 15)

Control Bits MOSI[15-14], C1-C0	Type of Command	Parity/Next MOSI[8] P/N	Note for Bit 8 P/N
00	Read back of register content and block (CAN, I/O, INT, LINS) real time state. See Table 39 .	1	Bit 8 must be set to 1, independently of the parity function selected or not selected.
01	Write to register address, to control the device operation	0	If bit 8 is set to "0": means parity not selected OR parity is selected AND parity = 0
		1	if bit 8 is set to "1": means parity is selected AND parity = 1
10	Reserved		
11	Read of device flags form a register address	1	Bit 8 must be set to 1, independently of the parity function selected or not selected.

10.2.2 Bits 13-9 functions

The device contains several registers coded on five bits (bits 13 to 9).

Each register controls or reports part of the device's function. Data can be written to the register to control the device operation or to set the default value or behavior. Every register can also be read back in order to ensure that it's content (default setting or value previously written) is correct. In addition, some of the registers are used to report device flags.

10.2.2.1 Device status on MISO

When a write operation is performed to store data or control bits into the device, the MISO pin reports a 16 bit fixed device status composed of 2 bytes: Device Fixed Status (bits 15 to 8) + extended Device Status (bits 7 to 0). In a read operation, MISO will report the Fixed device status (bits 15 to 8) and the next eight bits will be the content of the selected register.

10.2.3 Register address table

[Table 13](#) is a list of device registers and addresses, coded with bits 13 to 9.

Table 13. Device registers with corresponding address

Address MOSI[13-9] A4...A0	Description	Quick Ref. Name	Functionality
0_0000	Analog Multiplexer	MUX	1) Write 'device control bits' to register address. 2) Read back register 'control bits'
0_0001	Memory byte A	RAM_A	1) Write 'data byte' to register address. 2) Read back 'data byte' from register address
0_0010	Memory byte B	RAM_B	
0_0011	Memory byte C	RAM_C	
0_0100	Memory byte D	RAM_D	
0_0101	Initialization Regulators	Init REG	1) Write 'device initialization control bits' to register address. 2) Read back 'initialization control bits' from register address
0_0110	Initialization Watchdog	Init watchdog	
0_0111	Initialization LIN and I/O	Init LIN I/O	
0_1000	Initialization Miscellaneous functions	Init MISC	1) Write to register to select device Specific mode, using 'Inverted Random Code' 2) Read 'Random Code'
0_1001	Specific modes	SPE_MODE	

Table 13. Device registers with corresponding address (continued)

0_1010	Timer_A: watchdog & LP MCU consumption	TIM_A	1) Write 'timing values' to register address 2) Read back register 'timing values'
0_1011	Timer_B: Cyclic Sense & Cyclic Interrupt	TIM_B	
0_1100	Timer_C: watchdog LP & Forced Wake-up	TIM_C	
0_1101	Watchdog Refresh	watchdog	Watchdog Refresh Commands
0_1110	Mode register	MODE	1) Write to register to select LP mode, with optional "Inverted Random code" and select Wake-up functionality 2) Read operations: Read back device 'Current mode' Read 'Random Code', Leave 'Debug mode'
0_1111	Regulator Control	REG	1) Write 'device control bits' to register address, to select device operation. 2) Read back register 'control bits'. 3) Read device flags from each of the register addresses.
1_0000	CAN interface control	CAN	
1_0001	Input Output control	I/O	
1_0010	Interrupt Control	Interrupt	
1_0011	LIN1 interface control	LIN1	
1_0100	LIN2 interface control	LIN2	

10.2.4 Complete SPI operation

[Table 14](#) is a compiled view of all the SPI capabilities and options. Both MOSI and MISO information are described.

Table 14. SPI capabilities with options

Type of Command	MOSI/ MISO	Control bits [15-14]	Address [13-9]	Parity/Next bits [8]	Bit 7	Bits [6-0]
Read back of "device control bits" (MOSI bit 7 = 0) OR Read specific device information (MOSI bit 7 = 1)	MOSI	00	address	1	0	000 0000
	MISO	Device Fixed Status (8 bits)			Register control bits content	
Write device control bit to address selected by bits (13-9). MISO return 16 bits device status	MOSI	00	address	1	1	000 0000
	MISO	Device Fixed Status (8 bits)			Device ID and I/Os state	
Reserved	MOSI	10	Reserved			
	MISO	Reserved				
Read device flags and Wake-up flags, from register address (bit 13-9), and sub address (bit 7). MISO return fixed device status (bit 15-8) + flags from the selected address and sub-address.	MISO	11	address	Reserved	0	Read of device flags form a register address, and sub address LOW (bit 7)
	MOSI	Device Fixed Status (8 bits)			Flags	
	MISO	11	address	1	1	Read of device flags form a register address, and sub address HIGH (bit 7)
	MOSI	Device Fixed Status (8 bits)			Flags	

Note: P = 0 if parity bit is not selected or parity = 0. P = 1 if parity is selected and parity = 1.

10.2.5 Parity bit 8

10.2.5.1 Calculation

The parity is used for the write-to-register command (bit 15,14 = 01). It is calculated based on the number of logic one contained in bits 15-9,7-0 sequence (this is the entire 16 bits of the write command except bit 8).

Bit 8 must be set to 0 if the number of 1 is odd. Bit 8 must be set to 1 if the number of 1 is even.

10.2.5.2 Examples 1:

MOSI [bit 15-0] = 01 00 011 P 01101001, P should be 0, because the command contains 7 bits with logic 1. Thus the Exact command will then be: MOSI [bit 15-0] = 01 00 011 **0** 01101001

10.2.5.3 Examples 2:

MOSI [bit 15-0] = 01 00 011 P 0100 0000, P should be 1, because the command contains 4 bits with logic 1. Thus the Exact command will then be: MOSI [bit 15-0] = 01 00 011 **1** 0100 0000

10.2.5.4 Parity function selection

All SPI commands and examples do not use parity functions. The parity function is optional. It is selected by bit 6 in INIT MISC register. If parity function is not selected (bit 6 of INIT MISC = 0), then Parity bits in all SPI commands (bit 8) must be '0'.

10.3 Detail of control bits and register mapping

The following tables contain register bit meaning arranged by register address, from address 0_000 to address 1_0100

10.3.1 MUX and RAM registers

Table 15. MUX Register⁽³⁴⁾

MOSI First Byte [15-8] [b_15 b_14] 0_0000 [P/N]	MOSI Second Byte, bits 7-0							
	bit 7	bit 6	bit 5	bit 4	bit 3	bit 2	bit 1	bit 0
01 00 _ 000 P	MUX_2	MUX_1	MUX_0	Int 2K	I/O-att	0	0	0
Default state	0	0	0	0	0	0	0	0
Condition for default	POR, 5 V-CAN off, any mode different from Normal							

Bits	Description
b7 b6 b5	MUX_2, MUX_1, MUX_0 - Selection of external input signal or internal signal to be measured at MUX-OUT pin
000	All functions disable. No output voltage at MUX-OUT pin
001	V _{DD} regulator current recopy. Ratio is approx 1/97. Requires an external resistor or selection of Internal 2.0 K (bit 3)
010	Device internal voltage reference (approx 2.5 V)
011	Device internal temperature sensor voltage
100	Voltage at I/O-0. Attenuation or gain is selected by bit 3.
101	Voltage at I/O-1. Attenuation or gain is selected by bit 3.
110	Voltage at VSUP/1 pin. Refer to electrical table for attenuation ratio (approx 5)
111	Voltage at VSENSE pin. Refer to electrical table for attenuation ratio (approx 5)
b4	INT 2k - Select device internal 2.0 kohm resistor between AMUX and GND. This resistor allows the measurement of a voltage proportional to the V _{DD} output current.
0	Internal 2.0 kohm resistor disable. An external resistor must be connected between AMUX and GND.
1	Internal 2.0 kohm resistor enable.
b3	I/O-att - When I/O-0 (or I/O-1) is selected with b7,b6,b5 = 100 (or 101), b3 selects attenuation or gain between I/O-0 (or I/O-1) and MUX-OUT pin
0	Gain is approx 2 for device with V _{DD} = 5.0 V (Ref. to electrical table for exact gain value) Gain is approx 1.3 for device with V _{DD} = 3.3 V (Ref. to electrical table for exact gain value)
1	Attenuation is approx 4 for device with V _{DD} = 5.0 V (Ref. to electrical table for exact attenuation value) Attenuation is approx 6 for device with V _{DD} = 3.3 V (Ref. to electrical table for exact attenuation value)

Notes

34. The MUX register can be written and read only when the 5V-CAN regulator is ON. If the MUX register is written or read while 5V-CAN is OFF, the command is ignored, and the MXU register content is reset to default state (all control bits = 0).

Table 16. Internal memory registers A, B, C, and D, RAM_A, RAM_B, RAM_C, and RAM_D

MOSI First Byte [15-8] [b_15 b_14] 0_0xxx [P/N]	MOSI Second Byte, bits 7-0							
	Bit 7	Bit 6	Bit 5	Bit 4	Bit 3	Bit 2	Bit 1	Bit 0
01 00 _ 001 P	Ram a7	Ram a6	Ram a5	Ram a4	Ram a3	Ram a2	Ram a1	Ram a0
Default state	0	0	0	0	0	0	0	0
Condition for default	POR							
01 00 _ 010 P	Ram b7	Ram b6	Ram b5	Ram b4	Ram b3	Ram b2	Ram b1	Ram b0
Default state	0	0	0	0	0	0	0	0
Condition for default	POR							
01 00 _ 011 P	Ram c7	Ram c6	Ram c5	Ram c4	Ram c3	Ram c2	Ram c1	Ram c0
Default state	0	0	0	0	0	0	0	0
Condition for default	POR							
01 00 _ 100 P	Ram d7	Ram d6	Ram d5	Ram d4	Ram d3	Ram d2	Ram d1	Ram d0
Default state	0	0	0	0	0	0	0	0
Condition for default	POR							

10.3.2 INIT registers

Note: these registers can be written only in INIT mode

Table 17. Initialization regulator registers, INIT REG (note: register can be written only in INIT mode)

MOSI First Byte [15-8] [b_15 b_14] 0_0101 [P/N]	MOSI Second Byte, bits 7-0							
	bit 7	bit 6	bit 5	bit 4	bit 3	bit 2	bit 1	bit 0
01 00 _ 101 P	I/O-x sync	V _{DDL} rst[1]	V _{DDL} rst[0]	V _{DD} rstD[1]	V _{DD} rstD[0]	V _{AUX5/3}	Cyclic on[1]	Cyclic on[0]
Default state	1	0	0	0	0	0	0	0
Condition for default	POR							

Bit	Description
b7	I/O-x sync - Determine if I/O-1 is sensed during I/O-0 activation, when cyclic sense function is selected
0	I/O-1 sense anytime
1	I/O-1 sense during I/O-0 activation
b6, b5	V_{DDL} RST[1] V_{DDL} RST[0] - Select the V _{DD} undervoltage threshold, to activate $\overline{\text{RST}}$ pin and/or INT
00	Reset at approx 0.9 V _{DD} .
01	INT at approx 0.9 V _{DD} , Reset at approx 0.7 V _{DD}
10	Reset at approx 0.7 V _{DD}
11	Reset at approx 0.9 V _{DD} .
b4, b3	V_{DD} RSTD[1] V_{DD} RSTD[0] - Select the $\overline{\text{RST}}$ pin low lev duration, after V _{DD} rises above the V _{DD} undervoltage threshold
00	1.0 ms
01	5.0 ms
10	10 ms
11	20 ms
b2	[V_{AUX} 5/3] - Select Vauxiliary output voltage
0	V _{AUX} = 3.3 V
1	V _{AUX} = 5.0 V
b1, b0	Cyclic on[1] Cyclic on[0] - Determine I/O-0 activation time, when cyclic sense function is selected

Bit	Description
00	200 μ s (typical value. Ref. to dynamic parameters for exact value)
01	400 μ s (typical value. Ref. to dynamic parameters for exact value)
10	800 μ s (typical value. Ref. to dynamic parameters for exact value)
11	1600 μ s (typical value. Ref. to dynamic parameters for exact value)

Table 18. Initialization watchdog registers, INIT watchdog (note: register can be written only in INIT mode)

MOSI First Byte [15-8] [b_15 b_14] 0_0110 [P/N]	MOSI Second Byte, bits 7-0							
	bit 7	bit 6	bit 5	bit 4	bit 3	bit 2	bit 1	bit 0
01 00 _ 110 P	WD2INT	MCU_OC	OC-TIM	WD Safe	WD_spi[1]	WD_spi[0]	WD N/Win	Crank
Default state	0	1	0		0	0	1	0
Condition for default	POR							

Bit	Description
b7	WD2INT - Select the maximum time delay between INT occurrence and INT source read SPI command
0	Function disable. No constraint between INT occurrence and INT source read.
1	INT source read must occur before the remaining of the current watchdog period plus 2 complete watchdog periods.
b6, b5	MCU_OC, OC-TIM - In LP V_{DD} ON, select watchdog refresh and V_{DD} current monitoring functionality. $V_{DD_OC_LP}$ threshold is defined in device electrical parameters (approx 1.5 mA)
	In LP mode, when watchdog is not selected
no watchdog + 00	In LP V_{DD} ON mode, V_{DD} overcurrent has no effect
no watchdog + 01	In LP V_{DD} ON mode, V_{DD} overcurrent has no effect
no watchdog + 10	In LP V_{DD} ON mode, V_{DD} current > $V_{DD_OC_LP}$ threshold for a time > 100 μ s (typically) is a wake-up event
no watchdog + 11	In LP V_{DD} ON mode, V_{DD} current > $V_{DD_OC_LP}$ threshold for a time > I_mcu_OC is a wake-up event. I_mcu_OC time is selected in Timer register (selection range from 3.0 to 32 ms)
	In LP mode when watchdog is selected
watchdog + 00	In LP V_{DD} ON mode, V_{DD} current > $V_{DD_OC_LP}$ threshold has no effect. watchdog refresh must occur by SPI command.
watchdog + 01	In LP V_{DD} ON mode, V_{DD} current > $V_{DD_OC_LP}$ threshold has no effect. watchdog refresh must occur by SPI command.
watchdog + 10	In LP V_{DD} ON mode, V_{DD} overcurrent for a time > 100 μ s (typically) is a wake-up event.
watchdog + 11	In LP V_{DD} ON mode, V_{DD} current > $V_{DD_OC_LP}$ threshold for a time < I_mcu_OC is a watchdog refresh condition. V_{DD} current > $V_{DD_OC_LP}$ threshold for a time > I_mcu_OC is a wake-up event. I_mcu_OC time is selected in Timer register (selection range from 3.0 to 32 ms)
b4	WD Safe - Select the activation of the SAFE pin low, at first or second consecutive RESET pulse
0	SAFE pin is set low at the time of the \overline{RST} pin low activation
1	SAFE pin is set low at the second consecutive time \overline{RST} pulse
b3, b2	WD_spi[1] WD_spi[0] - Select the Watchdog (watchdog) Operation
00	Simple Watchdog selection: watchdog refresh done by a 8 bits or 16 bits SPI
01	Enhanced 1: Refresh is done using the Random Code, and by a single 16 bits.
10	Enhanced 2: Refresh is done using the Random Code, and by two 16 bits command.

Bit	Description
11	Enhanced 4: Refresh is done using the Random Code, and by four 16 bits command.
b1	WD N/Win - Select the Watchdog (watchdog) Window or Timeout operation
0	Watchdog operation is TIMEOUT, watchdog refresh can occur anytime in the period
1	Watchdog operation is WINDOW, watchdog refresh must occur in the open window (second half of period)
b0	Crank - Select the $V_{SUP/1}$ threshold to disable V_{DD} , while $V_{SUP/1}$ is falling toward GND
0	V_{DD} disable when $V_{SUP/1}$ is below typically 4.0 V (parameter V_{SUP_TH1}), and device in Reset mode
1	V_{DD} kept ON when $V_{SUP/1}$ is below typically 4.0 V (parameter V_{SUP_TH1})

Table 19. Initialization LIN and I/O registers, INIT LIN I/O (note: register can be written only in INIT mode)

MOSI First Byte [15-8] [b ₁₅ b ₁₄] 0_0111 [P/N]	MOSI Second Byte, bits 7-0							
	bit 7	bit 6	bit 5	bit 4	bit 3	bit 2	bit 1	bit 0
01 00 _ 111 P	I/O-1 ovoff	LIN_T2[1]	LIN_T2[0]	LIN_T/1[1]	LIN_T/1[0]	I/O-1 out-en	I/O-0 out-en	Cyc_Inv
Default state	0	0	0		0	0	0	0
Condition for default	POR							

Bit	Description
b7	I/O-1 ovoff - Select the deactivation of I/O-1 when V_{DD} or V_{AUX} overvoltage condition is detected
0	Disable I/O-1 turn off.
1	Enable I/O-1 turn off, when V_{DD} or V_{AUX} overvoltage condition is detected.
b6, b5	LIN_T2[1], LIN_T2[0] - Select pin operation as LIN Master pin switch or I/O
00	pin is OFF
01	pin operation as LIN Master pin switch
10	pin operation as I/O: HS switch and Wake-up input
11	N/A
b4, b3	LIN_T/1[1], LIN_T/1[0] - Select pin operation as LIN Master pin switch or I/O
00	pin is OFF
01	pin operation as LIN Master pin switch
10	pin operation as I/O: HS switch and Wake-up input
11	N/A
b2	I/O-1 out-en - Select the operation of the I/O-1 as output driver (HS, LS)
0	Disable HS and LS drivers of pin I/O-1. I/O-1 can only be used as input.
1	Enable HS and LS drivers of pin I/O-1. Pin can be used as input and output driver.
b1	I/O-0 out-en - Select the operation of the I/O-0 as output driver (HS, LS)
0	Disable HS and LS drivers of I/O-0 can only be used as input.
1	Enable HS and LS drivers of the I/O-0 pin. Pin can be used as input and output drivers.
b0	Cyc_Inv - Select I/O-0 operation in device LP mode, when cyclic sense is selected

Bit	Description
0	During cyclic sense active time, I/O is set to the same state prior to entering in to LP mode. During cyclic sense off time, I/O-0 is disable (HS and LS drivers OFF).
1	During cyclic sense active time, I/O is set to the same state prior to entering in to LP mode. During cyclic sense off time, the opposite driver of I/O_0 is actively set. Example: If I/O_0 HS is ON during active time, then I/O_0 LS is turned ON at expiration of the active time, for the duration of the cyclic sense period.

Table 20. Initialization Miscellaneous Functions, INIT MISC (Note: Register can be written only in INIT mode)

MOSI First Byte [15-8] [b_15 b_14] 0_1000 [P/N]	MOSI Second Byte, bits 7-0							
	bit 7	bit 6	bit 5	bit 4	bit 3	bit 2	bit 1	bit 0
01 01_000 P	LPM w RNDM	SPI parity	INT pulse	INT width	INT flash	Dbg Res[2]	Dbg Res[1]	Dbg Res[0]
Default state	0	0	0		0	0	0	0
Condition for default	POR							

Bit	Description
b7	LPM w RNDM - This enables the usage of random bits 2, 1 and 0 of the MODE register to enter into LP VDD OFF or LP VDD ON.
0	Function disable: the LP mode can be entered without usage of Random Code
1	Function enabled: the LP mode is entered using the Random Code
b6	SPI parity - Select usage of the parity bit in SPI write operation
0	Function disable: the parity is not used. The parity bit must always set to logic 0.
1	Function enable: the parity is used, and parity must be calculated.
b5	INT pulse -Select INT pin operation: low level pulse or low level
0	INT pin will assert a low level pulse, duration selected by bit [b4]
1	INT pin assert a permanent low level (no pulse)
b4	INT width - Select the INT pulse duration
0	INT pulse duration is typically 100 μ s. Ref. to dynamic parameter table for exact value.
1	INT pulse duration is typically 25 μ s. Ref. to dynamic parameter table for exact value.
b3	INT flash - Select INT pulse generation at 50% of the Watchdog Period in Flash mode
	Function disable
	Function enable: an INT pulse will occur at 50% of the Watchdog Period when device in Flash mode.
b2, b1, b0	Dbg Res[2], Dbg Res[1], Dbg Res[0] - Allow verification of the external resistor connected at DBG pin. Ref. to parametric table for resistor range value. ⁽³⁵⁾
0xx	Function disable
100	100 verification enable: resistor at DBG pin is typically 68 kohm (RB3) - Selection of SAFE mode B3
101	101 verification enable: resistor at DBG pin is typically 33 kohm (RB2) - Selection of SAFE mode B2
110	110 verification enable: resistor at DBG pin is typically 15 kohm (RB1) - Selection of SAFE mode B1
111	111 verification enable: resistor at DBG pin is typically 0 kohm (RA) - Selection of SAFE mode A

Notes

35. Bits b2,1 and 0 allow the following operation:

First, check the resistor device has detected at the DEBUG pin. If the resistor is different, bit 5 (Debug resistor) is set in INTERRUPT register (Ref. to device flag table).

Second, over write the resistor decoded by device, to set the SAFE mode operation by SPI. Once this function is selected by bit 2 = 1, this selection has higher priority than 'hardware', and device will behave according to b2,b1 and b0 setting

10.3.3 Specific mode register

Table 21. Specific mode register, SPE_MODE

MOSI First Byte [15-8] [b_15 b_14] 01_001 [P/N]	MOSI Second Byte, bits 7-0							
	bit 7	bit 6	bit 5	bit 4	bit 3	bit 2	bit 1	bit 0
01 01_ 001 P	Sel_Mod[1]	Sel_Mod[0]	Rnd_C5b	Rnd_C4b	Rnd_C3b	Rnd_C2b	Rnd_C1b	Rnd_C0b
Default state	0	0	0		0	0	0	0
Condition for default	POR							

Bit	Description
b7, b6	Sel_Mod[1], Sel_Mod[0] - Mode selection: these 2 bits are used to select which mode the device will enter upon a SPI command.
00	RESET mode
01	INIT mode
10	FLASH mode
11	N/A
b5...b0	[Rnd_C4b... Rnd_C0b] - Random Code inverted, these six bits are the inverted bits obtained from the SPE MODE Register read command.

10.3.3.1 The SPE mode register is used for the following operation

- Set the device in RESET mode, to exercise or test the RESET functions.
- Go to INIT mode, using the Secure SPi command.
- Go to FLASH mode (in this mode the watchdog timer can be extended up to 32 s).
- Activate the SAFE pin by S/W.

This mode (called Special mode) is accessible from the secured SPI command, which consist of 2 commands:

1) reading a random code and

2) then write the inverted random code plus mode selection or SAFE pin activation:

Return to INIT mode is done as follow (this is done from Normal mode only):

1) Read random code:

MOSI : 0001 0011 0000 0000 [Hex:0x 13 00]

MISO report 16 bits, random code are bits (5-0)

miso = xxxx xxxx xxR5 R4 R3 R2 R1 R0 (RXD = 6 bits random code)

2) Write INIT mode + random code inverted

MOSI : 0101 0010 01 Ri5 Ri4 Ri3 Ri2 Ri1 Ri0 [Hex 0x 52 HH] (R_{iX} = random code inverted)

MISO : xxxx xxxx xxxx xxxx (don't care)

SAFE pin activation: SAFE pin can be set low, only in INIT mode, with following commands:

1) Read random code:

MOSI : 0001 0011 0000 0000 [Hex:0x 13 00]

MISO report 16 bits, random code are bits (5-0)

miso = xxxx xxxx xxR5 R4 R3 R2 R1 R0 (RXD = 6 bits random code)

2) Write INIT mode + random code bits 5:4 not inverted and random code bits 3:0 inverted

MOSI : 0101 0010 01 R5 R4 Ri3 Ri2 Ri1 Ri0 [Hex 0x 52 HH] (R_{iX} = random code inverted)

MISO : xxxx xxxx xxxx xxxx (don't care)

Return to Reset or Flash mode is done similarly to the go to INIT mode, except that the b7 and b6 are set according to the table above (b7, b6 = 00 - go to reset, b7, b6 = 10 - go to Flash).

10.3.4 Timer registers

Table 22. Timer register A, LP V_{DD} overcurrent & watchdog period normal mode, TIM_A

MOSI First Byte [15-8] [b_15 b_14] 01_010 [P/N]	MOSI Second Byte, bits 7-0							
	bit 7	bit 6	bit 5	bit 4	bit 3	bit 2	bit 1	bit 0
01 01_ 010 P	I_mcu[2]	I_mcu[1]	I_mcu[1]	watchdog Nor[4]	W/D_N[4]	W/D_Nor[3]	W/D_N[2]	W/D_Nor[0]
Default state	0	0	0	1	1	1	1	0
Condition for default	POR							

LP V _{DD} overcurrent (ms)				
b7	b6, b5			
	00	01	10	11
0	3 (def)	6	12	24
1	4	8	16	32

Watchdog period in device normal mode (ms)								
b4, b3	b2, b1, b0							
	000	001	010	011	100	101	110	111
00	2.5	5	10	20	40	80	160	320
01	3	6	12	24	48	96	192	384
10	3.5	7	14	28	56	112	224	448
11	4	8	16	32	64	128	256 (def)	512

Table 23. Timer register B, cyclic sense and cyclic INT, in device LP mode, TIM_B

MOSI First Byte [15-8] [b_15 b_14] 01_011 [P/N]	MOSI Second Byte, bits 7-0							
	bit 7	bit 6	bit 5	bit 4	bit 3	bit 2	bit 1	bit 0
01 01_ 011 P	Cyc-sen[3]	Cyc-sen[2]	Cyc-sen[1]	Cyc-sen[0]	Cyc-int[3]	Cyc-int[2]	Cyc-int[1]	Cyc-int[0]
Default state	0	0	0	0	0	0	0	0
Condition for default	POR							

Cyclic sense (ms)								
b7	b6, b5, b4							
	000	001	010	011	100	101	110	111
0	3	6	12	24	48	96	192	384
1	4	8	16	32	64	128	256	512

Cyclic interrupt (ms)								
b3	b2, b1, b0							
	000	001	010	011	100	101	110	111
0	6 (def)	12	24	48	96	192	384	768
1	8	16	32	64	128	258	512	1024

Table 24. Timer register C, watchdog LP mode or flash mode and forced wake-up timer, TIM_C

MOSI First Byte [15-8] [b_15 b_14] 01_100 [P/N]	MOSI Second Byte, bits 7-0							
	bit 7	bit 6	bit 5	bit 4	bit 3	bit 2	bit 1	bit 0
01 01_ 100 P	WD-LP-F[3]	WD-LP-F[2]	WD-LP-F[1]	WD-LP-F[0]	FWU[3]	FWU[2]	FWU[1]	FWU[0]
Default state	0	0	0	0	0	0	0	0
Condition for default	POR							

Table 25. Typical timing values

Watchdog in LP V _{DD} ON mode (ms)								
b7	b6, b5, b4							
	000	001	010	011	100	101	110	111
0	12	24	48	96	192	384	768	1536
1	16	32	64	128	256	512	1024	2048

Watchdog in flash mode (ms)								
b7	b6, b5, b4							
	000	001	010	011	100	101	110	111
0	48 (def)	96	192	384	768	1536	3072	6144
1	256	512	1024	2048	4096	8192	16384	32768

Forced wake-up (ms)								
b3	b2, b1, b0							
	000	001	010	011	100	101	110	111
0	48 (def)	96	192	384	768	1536	3072	6144
1	64	128	258	512	1024	2048	4096	8192

10.3.5 Watchdog and mode registers

Table 26. Watchdog refresh register, watchdog⁽³⁶⁾

MOSI First Byte [15-8] [b_15 b_14] 01_101 [P/N]	MOSI Second Byte, bits 7-0							
	bit 7	bit 6	bit 5	bit 4	bit 3	bit 2	bit 1	bit 0
01 01_ 101 P	0	0	0	0	0	0	0	0
Default state	0	0	0	0	0	0	0	0
Condition for default	POR							

Notes

36. The Simple Watchdog Refresh command is in hexadecimal: 5A00. This command is used to refresh the watchdog and also to transition from INIT mode to Normal mode, and from Normal Request mode to Normal mode (after a wake-up of a reset)

Table 27. MODE register, mode

MOSI First Byte [15-8] [b ₁₅ b ₁₄] 01 ₁₁₀ [P/N]	MOSI Second Byte, bits 7-0							
	bit 7	bit 6	bit 5	bit 4	bit 3	bit 2	bit 1	bit 0
01 01 ₁₁₀ P	mode[4]	mode[3]	mode[2]	mode[1]	mode[0]	Rnd_b[2]	Rnd_b[1]	Rnd_b[0]
Default state	N/A	N/A	N/A	N/A	N/A	N/A	N/A	N/A

Table 28. LP V_{DD} off selection and FWU / cyclic sense selection

b7, b6, b5, b4, b3	FWU	Cyclic Sense
0 1100	OFF	OFF
0 1101	OFF	ON
0 1110	ON	OFF
0 1111	ON	ON

Table 29. LP V_{DD} on selection and operation mode

b7, b6, b5, b4, b3	FWU	Cyclic Sense	Cyclic INT	Watchdog
1 0000	OFF	OFF	OFF	OFF
1 0001	OFF	OFF	OFF	ON
1 0010	OFF	OFF	ON	OFF
1 0011	OFF	OFF	ON	ON
1 0100	OFF	ON	OFF	OFF
1 0101	OFF	ON	OFF	ON
1 0110	OFF	ON	ON	OFF
1 0111	OFF	ON	ON	ON
1 1000	ON	OFF	OFF	OFF
1 1001	ON	OFF	OFF	ON
1 1010	ON	OFF	ON	OFF
1 1011	ON	OFF	ON	ON
1 1100	ON	ON	OFF	OFF
1 1101	ON	ON	OFF	ON
1 1110	ON	ON	ON	OFF
1 1111	ON	ON	ON	ON
b2, b1, b0	Random Code inverted, these 3bits are the inverted bits obtained from the previous SPI command. The usage of these bits are optional and must be previously selected in the INIT MISC register [See bit 7 (LPM w RNDM) in Table 20]			

Prior to enter in LP V_{DD} ON or LP V_{DD} OFF, the Wake-up flags must be cleared or read.

This is done by the following SPI commands (See [Table 39, Device flag, I/O real time and device identification](#)):

0xE100 for CAN Wake-up clear

0xE380 for I/O Wake-up clear

0xE700 for LIN1 Wake-up clear

0xE900 for LIN2 Wake-up clear

If Wake-up flags are not cleared, the device will enter into the selected LP mode and immediately Wake-up. In addition, the CAN failure flags (i.e. CAN_F and CAN_UF) must be cleared in order to meet the low power current consumption specification. This is done by the following SPI command:

0xE180 (read CAN failure flags)

When the device is in LP V_{DD} ON mode, the Wake-up by a SPI command uses a write to 'Normal Request mode', 0x5C10.

10.3.5.1 Mode register features

The mode register includes specific functions and a 'global SPI command' that allow the following:

- read device current mode
- read device Debug status
- read state of SAFE pin
- leave Debug state
- release or turn off SAFE pin
- read a 3 bit Random Code to enter in LP mode

These global commands are built using the MODE register address bit [13-9], along with several combinations of bit [15-14] and bit [7]. Note, bit [8] is always set to 1.

10.3.5.2 Entering into LP mode using random code

- LP mode using Random Code must be selected in INIT mode via bit 7 of the INIT MISC register.
- In Normal mode, read the Random Code using 0x1D00 or 0x1D80 command. The 3 Random Code bits are available on MISO bits 2,1 and 0.
- Write LP mode by inverting the 3 random bits.

Example - Select LP VDD OFF without cyclic sense and FWU:

1. in hex: 0x5C60 to enter in LP VDD OFF mode without using the 3 random code bits.
2. if Random Code is selected, the commands are:

- Read Random Code: 0x1D00 or 0x1D80,

MISO report in binary: bits 15-8, bits 7-3, Rnd_[2], Rnd_[1], Rnd_[0].

- Write LP VDD OFF mode, using Random Code inverted:

in binary: 0101 1100 0110 0 Rnd_b[2], Rnd_b[1], Rnd_b[0].

[Table 30](#) summarizes these commands

Table 30. Device modes

Global commands and effects								
Read device current mode, Leave debug mode. Keep SAFE pin as is. MOSI in hexadecimal: 1D 00	MOSI	bits 15-14	bits 13-9	bit 8	bit 7	bits 6-0		
		00	01 110	1	0	000 0000		
	MISO	bit 15-8		bit 7-3		bit 2-0		
		Fix Status		device current mode		Random code		
Read device current mode Release SAFE pin (turn OFF). MOSI in hexadecimal: 1D 80	MOSI	bits 15-14	bits 13-9	bit 8	bit 7	bits 6-0		
		00	01 110	1	1	000 0000		
	MISO	bit 15-8		bit 7-3		bit 2-0		
		Fix Status		device current mode		Random code		
Read device current mode, Leave debug mode. Keep SAFE pin as is. MOSI in hexadecimal: DD 00 MISO reports Debug and SAFE state (bits 1,0)	MOSI	bits 15-14	bits 13-9	bit 8	bit 7	bits 6-0		
		11	01 110	1	0	000 0000		
	MISO	bit 15-8		bit 7-3		bit 2	bit 1	bit 0
		Fix Status		device current mode		X	SAFE	DEBUG
Read device current mode, Keep DEBUG mode Release SAFE pin (turn OFF). MOSI in hexadecimal: DD 80 MISO reports Debug and SAFE state (bits 1,0)	MOSI	bits 15-14	bits 13-9	bit 8	bit 7	bits 6-0		
		11	01 110	1	1	000 0000		
	MISO	bit 15-8		bit 7-3		bit 2	bit 1	bit 0
		Fix Status		device current mode		X	SAFE	DEBUG

[Table 31](#) describes MISO bits 7-0, used to decode the device's current mode.

Table 31. MISO bits 7-3

Device current mode, any of the above commands	
b7, b6, b5, b4, b3	MODE
0 0000	INIT
0 0001	FLASH
0 0010	Normal Request
0 0011	Normal mode
1 XXXX	Low Power mode (Table 29)

[Table 32](#) describes the SAFE and DEBUG bit decoding.

Table 32. SAFE and DEBUG status

SAFE and DEBUG bits	
b1	description
0	SAFE pin ON, driver activated
1	SAFE pin OFF, not activated
b0	description
0	Debug mode OFF
1	Debug mode Active

10.3.6 Regulator, CAN, I/O, INT and Iin registers

Table 33. Regulator register

MOSI First Byte [15-8] [b_15 b_14] 01_111 [P/N]	MOSI Second Byte, bits 7-0							
	bit 7	bit 6	bit 5	bit 4	bit 3	bit 2	bit 1	bit 0
01 01_ 111 P	V _{AUX} [1]	V _{AUX} [0]	-	5V-can[1]	5V-can[0]	V _{DD} bal en	V _{DD} bal auto	V _{DD} OFF en
Default state	0	0	N/A	0	0	N/A	N/A	N/A
Condition for default	POR			POR				

Bits	Description
b7 b6	V_{AUX}[1], V_{AUX}[0] - Vauxiliary regulator control
00	Regulator OFF
01	Regulator ON. undervoltage (UV) and Overcurrent (OC) monitoring flags not reported. V _{AUX} is disabled when UV or OC detected after 1.0 ms blanking time.
10	Regulator ON. undervoltage (UV) and overcurrent (OC) monitoring flags active. V _{AUX} is disabled when UV or OC detected after 1.0 ms blanking time.
11	Regulator ON. undervoltage (UV) and overcurrent (OC) monitoring flags active. V _{AUX} is disabled when UV or OC detected after 25 μs blanking time.
b4 b3	5 V-can[1], 5 V-can[0] - 5V-CAN regulator control
00	Regulator OFF
01	Regulator ON. Thermal protection active. undervoltage (UV) and overcurrent (OC) monitoring flags not reported. 1.0 ms blanking time for UV and OC detection. Note: by default when in Debug mode
10	Regulator ON. Thermal protection active. undervoltage (UV) and overcurrent (OC) monitoring flags active. 1.0 ms blanking time for UV and OC detection.
11	Regulator ON. Thermal protection active. undervoltage (UV) and overcurrent (OC) monitoring flags active after 25 μs blanking time.
b2	V_{DD} bal en - Control bit to Enable the V _{DD} external ballast transistor
0	External V _{DD} ballast disable
1	External V _{DD} ballast Enable
b1	V_{DD} bal auto - Control bit to automatically Enable the V _{DD} external ballast transistor, if V _{DD} is > typically 60 mA
0	Disable the automatic activation of the external ballast
1	Enable the automatic activation of the external ballast, if V _{DD} > typically 60 mA
b0	V_{DD} OFF en - Control bit to allow transition into LP V _{DD} OFF mode (to prevent V _{DD} turn OFF)
0	Disable Usage of LP V _{DD} OFF mode
1	Enable Usage of LP V _{DD} OFF mode

Table 34. CAN register⁽³⁷⁾

MOSI First byte [15-8] [b_15 b_14] 10_000 [P/N]	MOSI Second Byte, bits 7-0							
	bit 7	bit 6	bit 5	bit 4	bit 3	bit 2	bit 1	bit 0
01 10_000P	CAN mod[1]	CAN mod[0]	Slew[1]	Slew[0]	Wake-up 1/3	-	-	CAN int
Default state	1	0	0	0	0	-	-	0
Condition for default	note		POR		POR			POR

Bits	Description
b7 b6	CAN mod[1], CAN mod[0] - CAN interface mode control, Wake-up enable / disable
00	CAN interface in Sleep mode, CAN Wake-up disable.
01	CAN interface in receive only mode, CAN driver disable.
10	CAN interface is in Sleep mode, CAN Wake-up enable. In device LP mode, CAN Wake-up is reported by device Wake-up. In device Normal mode, CAN Wake-up reported by INT.
11	CAN interface in transmit and receive mode.
b5 b4	Slew[1] Slew[0] - CAN driver slew rate selection
00/11	FAST
01	MEDIUM
10	SLOW
b3	Wake-up 1/3 - Selection of CAN Wake-up mechanism
0	3 dominant pulses Wake-up mechanism
1	Single dominant pulse Wake-up mechanism
b0	CAN INT - Select the CAN failure detection reporting
0	Select INT generation when a bus failure is fully identified and decoded (i.e. after 5 dominant pulses on TxCAN)
1	Select INT generation as soon as a bus failure is detected, event if not fully identified

Notes

37. The first time the device is set to Normal mode, the CAN is in Sleep Wake-up enabled (bit7 = 1, bit 6 =0). The next time the device is set in Normal mode, the CAN state is controlled by bits 7 and 6.

Table 35. I/O register

MOSI First byte [15-8] [b_15 b_14] 10_001 [P/N]	MOSI Second Byte, bits 7-0							
	bit 7	bit 6	bit 5	bit 4	bit 3	bit 2	bit 1	bit 0
01 10_001P	I/O-3 [1]	I/O-3 [0]	I/O-2 [1]	I/O-2 [0]	I/O-1 [1]	I/O-1 [0]	I/O-0 [1]	I/O-0 [0]
Default state	0	0	0	0	0	0	0	0
Condition for default	POR							

Bits	Description
b7 b6	I/O-3 [1], I/O-3 [0] - I/O-3 pin operation
00	I/O-3 driver disable, Wake-up capability disable
01	I/O-3 driver disable, Wake-up capability enable.
10	I/O-3 HS driver enable.
11	I/O-3 HS driver enable.
b5 b4	I/O-2 [1], I/O-2 [0] - I/O-2 pin operation
00	I/O-2 driver disable, Wake-up capability disable
01	I/O-2 driver disable, Wake-up capability enable.
10	I/O-2 HS driver enable.
11	I/O-2 HS driver enable.
b3 b2	I/O-1 [1], I/O-1 [0] - I/O-1 pin operation
00	I/O-1 driver disable, Wake-up capability disable
01	I/O-1 driver disable, Wake-up capability enable.
10	I/O-1 LS driver enable.
11	I/O-1 HS driver enable.
b1 b0	I/O-0 [1], I/O-0 [0] - I/O-0 pin operation
00	I/O-0 driver disable, Wake-up capability disable
01	I/O-0 driver disable, Wake-up capability enable.
10	I/O-0 LS driver enable.
11	I/O-0 HS driver enable.

Table 36. INT register

MOSI First byte [15-8] [b_15 b_14] 10_010 [P/N]	MOSI Second Byte, bits 7-0							
	bit 7	bit 6	bit 5	bit 4	bit 3	bit 2	bit 1	bit 0
01 10_010P	CAN failure	MCU req	LIN2 fail	LIN1fail	I/O	SAFE	-	Vmon
Default state	0	0	0	0	0	0	0	0
Condition for default	POR							

Bits	Description
b7	CAN failure - control bit for CAN failure INT (CANH/L to GND, VDD or VSUP, CAN overcurrent, Driver Overtemp, TXD-PD, RXD-PR, RX2HIGH, and CANBUS Dominate clamp)
0	INT disable
1	INT enable.
b6	MCU req - Control bit to request an INT. INT will occur once when the bit is enable
0	INT disable
1	INT enable.
b5	LIN2 fail - Control bit to enable INT when of failure on LIN2 interface
0	INT disable
1	INT enable.
b4	LIN/1 fail - Control bit to enable INT when of failure on LIN1 interface
0	INT disable
1	INT enable.
b3	I/O - Bit to control I/O interruption: I/O failure
0	INT disable
1	INT enable.
b2	SAFE - Bit to enable INT when of: Vaux overvoltage, VDD overvoltage, VDD Temp pre-warning, VDD undervoltage ⁽³⁸⁾ , SAFE resistor mismatch, RST terminal short to VDD, MCU request INT. ⁽³⁹⁾
0	INT disable
1	INT enable.
b0	V_{MON} - enable interruption by voltage monitoring of one of the voltage regulator: V _{AUX} , 5 V-CAN, V _{DD} (I _{DD} Overcurrent, V _{SUV} , V _{SOV} , V _{SENSELOW} , 5V-CAN low or thermal shutdown, V _{AUX} low or V _{AUX} overcurrent
0	INT disable
1	INT enable.

Notes

38. If VDD undervoltage is set to 70% of VDD, see bits b6 and b5 in Table 15 on page 69.
39. Bit 2 is used in conjunction with bit 6. Both bit 6 and bit 2 must be set to 1 to activate the MCU INT request.

Table 37. LIN/1 Register⁽⁴¹⁾

MOSI First byte [15-8] [b_15 b_14] 10_010 [P/N]	MOSI Second Byte, bits 7-0							
	bit 7	bit 6	bit 5	bit 4	bit 3	bit 2	bit 1	bit 0
01 10_011P	LIN mode[1]	LIN mode[0]	Slew rate[1]	Slew rate[0]	-	LIN T/1 on	-	V _{SUP} ext
Default state	0	0	0	0	0	0	0	0
Condition for default	POR							

Bits	Description
b7 b6	LIN mode [1], LIN mode [0] - LIN/1 interface mode control, Wake-up enable / disable
00	LIN/1 disable, Wake-up capability disable
01	not used
10	LIN/1 disable, Wake-up capability enable
11	LIN/1 Transmit Receive mode ⁽⁴⁰⁾
b5 b4	Slew rate[1], Slew rate[0] LIN/1 slew rate selection
00	Slew rate for 20 kbit/s baud rate
01	Slew rate for 10 kbit/s baud rate
10	Slew rate for fast baud rate
11	Slew rate for fast baud rate
b2	LIN T/1 on
0	LIN/1 termination OFF
1	LIN/1 termination ON
b0	V _{SUP} ext
0	LIN goes recessive when device V _{SUP/2} is below typically 6.0 V. This is to meet J2602 specification
1	LIN continues operation below V _{SUP/2} 6.0 V, until 5 V-CAN is disabled.

Notes

40. The LIN interface can be set in TXD/RXD mode only when the TXD-L input signal is in recessive state. An attempt to set TXD/RXD mode, while TXD-L is low, will be ignored and the LIN interface remains disabled.
41. In order to use the LIN interface, the 5V-CAN regulator must be set to ON.

Table 38. LIN2 register⁽⁴³⁾

MOSI First byte [15-8] [b_15 b_14] 10_010 [P/N]	MOSI Second Byte, bits 7-0							
	bit 7	bit 6	bit 5	bit 4	bit 3	bit 2	bit 1	bit 0
01 10_ 100P	LIN mode[1]	LIN mode[0]	Slew rate[1]	Slew rate[0]	-	LIN T2 on	-	V _{SUP} ext
Default state	0	0	0	0	0	0	0	0
Condition for default	POR							

Bits	Description
b7 b6	LIN mode [1], LIN mode [0] - LIN 2 interface mode control, Wake-up enable / disable
00	LIN2 disable, Wake-up capability disable
01	not used
10	LIN2 disable, Wake-up capability enable
11	LIN2 Transmit Receive mode ⁽⁴²⁾
b5 b4	Slew rate[1], Slew rate[0] LIN 2slew rate selection
00	Slew rate for 20 kbit/s baud rate
01	Slew rate for 10 kbit/s baud rate
10	Slew rate for fast baud rate
11	Slew rate for fast baud rate
b2	LIN T2 on
0	LIN 2 termination OFF
1	LIN 2 termination ON
b0	V _{SUP} ext
0	LIN goes recessive when device V _{SUP/2} is below typically 6.0 V. This is to meet J2602 specification
1	LIN continues operation below V _{SUP/2} 6.0 V, until 5 V-CAN is disabled.

Notes

42. The LIN interface can be set in TXD/RXD mode only when the TXD-L input signal is in a recessive state. An attempt to set TXD/RXD mode while TXD-L is low, will be ignored and the LIN interface will remain disabled.
43. In order to use the LIN interface, the 5V-CAN regulator must be set to ON.

10.4 Flags and device status

10.4.1 Description

The table below is a summary of the device flags, I/O real time level, device Identification, and includes examples of SPI commands (SPI commands do not use parity functions). They are obtained using the following commands.

This command is composed of the following:

bits 15 and 14:

- [1 1] for failure flags
- - [0 0] for I/O real time status, device identification and CAN LIN driver receiver real time state.
- bit 13 to 9 are the register address from which the flags is to be read.
- bit 8 = 1 (this is not parity bit function, as this is a read command).

When a failure event occurs, the respective flag is set and remains latched until it is cleared by a read command (provided the failure event has recovered).

Table 39. Device flag, I/O real time and device identification

Bits	15-14	13-9	8	7	6	5	4	3	2	1	0	
MOSI	MOSI bits 15-7				Next 7 MOSI bits (bits 6.0) should be "000_0000"							
	bits [15, 14]	Address [13-9]	bit 8	bit 7								
MISO	8 Bits Device Fixed Status (bits 15...8)				MISO bits [7-0], device response on MISO pin							
					bit 7	bit 6	bit 5	bit 4	bit 3	bit 2	bit 1	bit 0
REG	11	0_1111 REG	1	0	V _{AUX_LOW}	V _{AUX_overCURRENT}	5V _{-CAN_THERMAL SHUTDOWN}	5V _{-CAN_UV}	5V _{-CAN_overCURRENT}	V _{SENSE_LOW}	V _{SUP_underVOLTAGE}	I _{DD-OC-NORMAL MODE}
	11			1	-	-	-	V _{DD_THERMAL SHUTDOWN}		R _{ST_LOW} (<100 ms)	V _{SUP_BATFAIL}	I _{DD-OC-LP V_{DDON} MODE}
Hexa SPI commands to get Vreg Flags: MOSI 0x DF 00, and MOSI 0x DF 80												
CAN	11	1_0000 CAN	1	0	CAN Wake-up	-	CAN Overtemp	RXD low ⁽⁴⁴⁾	Rxd high	TXD dom	Bus Dom clamp	CAN Overcurrent
				1	CAN_UF	CAN_F	CANL to V _{BAT}	CANL to V _{DD}	CANL to GND	CANH to V _{BAT}	CANH to V _{DD}	CANH to GND
Hexa SPI commands to get CAN Flags: MOSI 0x E1 00, and MOSI 0x E1 80												
	00	1_0000 CAN	1	1	CAN Driver State	CAN Receiver State	CAN WU en/dis	-	-	-	-	-
Hexa SPI commands to get CAN real time status: MOSI 0x 21 80												
I/O	11	1_0001 I/O	1	0	HS3 short to GND	HS2 short to GND	SPI parity error	CSB low >2.0 ms	V _{SUP/2-UV}	V _{SUP/1-OV}	I/O_0 thermal	watchdog flash mode 50%
				1	I/O_1-3 Wake-up	I/O_0-2 Wake-up	SPI Wake-up	FWU	INT service Timeout	LP V _{DD} OFF	Reset request	Hardware Leave Debug
Hexa SPI commands to get I/O Flags and I/O Wake-up: MOSI 0x E3 00, and MOSI 0x E3 80												
	00	1_0001 I/O	1	1		I/O_3 state		I/O_2 state		I/O_1 state		I/O_0 state
Hexa SPI commands to get I/O real time level: MOSI 0x 23 80												
SAFE	11	1_0010 SAFE	1	0	INT request	RST high	DBG resistor	V _{DD} temp Pre-warning	V _{DD} UV	V _{DD} Overvoltage	V _{AUX_overVOLTAGE}	-
				1	-	-	-	V _{DD} low >100 ms	V _{DD} low RST	RST low >100 ms	multiple Resets	watchdog refresh failure
Hexa SPI commands to get INT and RST Flags: MOSI 0x E5 00, and MOSI 0x E5 80												
	00	1_0010 SAFE	1	1	V _{DD} (5.0 V or 3.3 V)	device p/n 1	device p/n 0	id4	id3	id2	id1	id0
Hexa SPI commands to get device Identification: MOSI 0x 2580 example: MISO bit [7-0] = 1011 0100: MC33904, 5.0 V version, silicon Rev. C and D												
LIN/1	11	1_0011 LIN 1	1	0	-	LIN1 Wake-up	LIN1 Term short to GND	LIN 1 Overtemp	RXD1 low	RXD1 high	TXD1 dom	LIN1 bus dom clamp
					Hexa SPI commands to get LIN 2 Flags: MOSI 0x E7 00							
	00	1_0011 LIN 1	1	1	LIN1 State	LIN1 WU en/dis	-	-	-	-	-	-

Table 39. Device flag, I/O real time and device identification

Hexa SPI commands to get LIN1 real time status: MOSI 0x 27 80												
LIN2	11	1_0100 LIN 2	1	0	-	LIN2 Wake-up	LIN2 Term short to GND	LIN 2 Overtemp	RXD2 low	RXD2 high	TXD2 dom	LIN2 bus dom clamp
Hexa SPI commands to get LIN 2 Flags: MOSI 0x E9 00												
	00	1_0100 LIN 2	1	1	LIN2 State	LIN2 WU en/dis	-	-	-	-	-	-
Hexa SPI commands to get LIN2 real time status: MOSI 0x 29 80												

Notes

44. Not available on 'C' and 'D' versions

Table 40. Flag descriptions

Flag	Description	
REG		
V _{AUX_LOW}	Description	Reports that V _{AUX} regulator output voltage is lower than the V _{AUX_UV} threshold.
	Set / Reset condition	Set: V _{AUX} below threshold for t > 100 μs typically. Reset: V _{AUX} above threshold and flag read (SPI)
V _{AUX_OverCURRENT}	Description	Report that current out of V _{AUX} regulator is above V _{AUX_OC} threshold.
	Set / Reset condition	Set: Current above threshold for t > 100 μs. Reset: Current below threshold and flag read by SPI.
5 V _{CAN_THERMAL SHUTDOWN}	Description	Report that the 5 V-CAN regulator has reached overtemperature threshold.
	Set / Reset condition	Set: 5 V-CAN thermal sensor above threshold. Reset: thermal sensor below threshold and flag read (SPI)
5V _{CAN_UV}	Description	Reports that 5 V _{CAN} regulator output voltage is lower than the 5 V _{CAN_UV} threshold.
	Set / Reset condition	Set: 5V-CAN below 5V _{CAN_UV} for t > 100 μs typically. Reset: 5V-CAN > threshold and flag read (SPI)
5V-can _{overcurrent}	Description	Report that the CAN driver output current is above threshold.
	Set / Reset condition	Set: 5V-CAN current above threshold for t > 100 μs. Reset: 5V-CAN current below threshold and flag read (SPI)
V _{SENSE_LOW}	Description	Reports that VSENSE pin is lower than the V _{SENSE_LOW} threshold.
	Set / Reset condition	Set: VSENSE below threshold for t > 100 μs typically. Reset: V _{SENSE} above threshold and flag read (SPI)
V _{SUP_UNDERVOLTAGE}	Description	Reports that VSUP/1 pin is lower than the V _{S1_LOW} threshold.
	Set / Reset condition	Set: V _{SUP/1} below threshold for t > 100 μs typically. Reset: V _{SUP/1} above threshold and flag read (SPI)
I _{DD-OC-NORMAL MODE}	Description	Report that current out of VDD pin is higher that I _{DD-OC} threshold, while device is in Normal mode.
	Set / Reset condition	Set: current above threshold for t > 100 μs typically. Reset; current below threshold and flag read (SPI)
V _{DD_THERMAL SHUTDOWN}	Description	Report that the V _{DD} has reached overtemperature threshold, and was turned off.
	Set / Reset condition	Set: V _{DD} OFF due to thermal condition. Reset: V _{DD} recover and flag read (SPI)
R _{ST_LOW} (<100 ms)	Description	Report that the RST pin has detected a low level, shorter than 100 ms
	Set / Reset condition	Set: after detection of reset low pulse. Reset: Reset pulse terminated and flag read (SPI)
V _{SUP_BATFAIL}	Description	Report that the device voltage at VSUP/1 pin was below BATFAIL threshold.
	Set / Reset condition	Set: V _{SUP/1} below BATFAIL. Reset: V _{SUP/1} above threshold, and flag read (SPI)
I _{DD-OC-LP V_{DD}ON mode}	Description	Report that current out of VDD pin is higher that I _{DD-OC} threshold LP, while device is in LP V _{DD} ON mode.
	Set / Reset condition	Set: current above threshold for t > 100 μs typically. Reset; current below threshold and flag read (SPI)

Table 40. Flag descriptions

Flag	Description	
CAN		
CAN driver state	Description	Report real time CAN bus driver state: 1 if Driver is enable, 0 if driver disable
	Set / Reset condition	Set: CAN driver is enable. Reset: CAN driver is disable. Driver can be disable by SPI command (ex CAN set in RXD only mode) or following a failure event (ex: TXD Dominant). Flag read SPI command (0x2180) do not clear the flag, as it is "real time" information.
CAN receiver state	Description	Report real time CAN bus receiver state: 1 if Enable, 0 if disable
	Set / Reset condition	Set: CAN bus receiver is enable. Reset: CAN bus receiver is disable. Receiver disable by SPI command (ex: CAN set in sleep mode). Flag read SPI command (0x2180) do not clear the flag, as it is "real time" information.
CAN WU enable	Description	Report real time CAN bus Wake-up receiver state: 1 if WU receiver is enable, 0 if disable
	Set / Reset condition	Set: CAN Wake-up receiver is enable. Reset: CAN Wake-up receiver is disable. Wake-up receiver is controlled by SPI, and is active by default after device Power ON. SPI command (0x2180) do not change flag state.
CAN Wake-up	Description	Report that Wake-up source is CAN
	Set / Reset condition	Set: after CAN wake detected. Reset: Flag read (SPI)
CAN Overtemp	Description	Report that the CAN interface has reach overtemperature threshold.
	Set / Reset condition	Set: CAN thermal sensor above threshold. Reset: thermal sensor below threshold and flag read (SPI)
RXD low ⁽⁴⁵⁾	Description	Report that RXD pin is shorted to GND.
	Set / Reset condition	Set: RXD low failure detected. Reset: failure recovered and flag read (SPI)
Rxd high	Description	Report that RXD pin is shorted to recessive voltage.
	Set / Reset condition	Set: RXD high failure detected. Reset: failure recovered and flag read (SPI)
TXD dom	Description	Report that TXD pin is shorted to GND.
	Set / Reset condition	Set: TXD low failure detected. Reset: failure recovered and flag read (SPI)
Bus Dom clamp	Description	Report that the CAN bus is dominant for a time longer than t_{DOM}
	Set / Reset condition	Set: Bus dominant clamp failure detected. Reset: failure recovered and flag read (SPI)
CAN Overcurrent	Description	Report that the CAN current is above CAN overcurrent threshold.
	Set / Reset condition	Set: CAN current above threshold. Reset: current below threshold and flag read (SPI)
CAN_UF	Description	Report that the CAN failure detection has not yet identified the bus failure
	Set / Reset condition	Set: bus failure pre detection. Reset: CAN bus failure recovered and flag read
CAN_F	Description	Report that the CAN failure detection has identified the bus failure
	Set / Reset condition	Set: bus failure complete detetction. Reset: CAN bus failure recovered and flag read
CANL to V_{BAT}	Description	Report CAN L short to V_{BAT} failure
	Set / Reset condition	Set: failure detected. Reset failure recovered and flag read (SPI)
CANL to VDD	Description	Report CANL short to VDD
	Set / Reset condition	Set: failure detected. Reset failure recovered and flag read (SPI)
CANL to GND	Description	Report CAN L short to GND failure
	Set / Reset condition	Set: failure detected. Reset failure recovered and flag read (SPI)
CANH to V_{BAT}	Description	Report CAN H short to V_{BAT} failure
	Set / Reset condition	Set: failure detected. Reset failure recovered and flag read (SPI)
CANH to VDD	Description	Report CANH short to VDD
	Set / Reset condition	Set: failure detected. Reset failure recovered and flag read (SPI)
CANH to GND	Description	Report CAN H short to GND failure
	Set / Reset condition	Set: failure detected. Reset failure recovered and flag read (SPI)

Notes

45. Not available on 'C' and 'D' versions

Table 40. Flag descriptions

Flag	Description	
I/O		
HS3 short to GND	Description	Report I/O-3 HS switch short to GND failure
	Set / Reset condition	Set: failure detected. Reset failure recovered and flag read (SPI)
HS2 short to GND	Description	Report I/O-2 HS switch short to GND failure
	Set / Reset condition	Set: failure detected. Reset failure recovered and flag read (SPI)
SPI parity error	Description	Report SPI parity error was detected.
	Set / Reset condition	Set: failure detected. Reset: flag read (SPI)
CSB low >2.0 ms	Description	Report SPI CSB was low for a time longer than typically 2.0 ms
	Set / Reset condition	Set: failure detected. Reset: flag read (SPI)
V _{SUP/2} -UV	Description	Report that V _{SUP/2} is below V _{S2_LOW} threshold.
	Set / Reset condition	Set V _{SUP/2} below V _{S2_LOW} thresh. Reset V _{SUP/2} > V _{S2_LOW} thresh and flag read (SPI)
V _{SUP/1} -OV	Description	Report that V _{SUP/1} is above V _{S_HIGH} threshold.
	Set / Reset condition	Set V _{SUP/1} above V _{S_HIGH} threshold. Reset V _{SUP/1} < V _{S_HIGH} thresh and flag read (SPI)
I/O-0 thermal	Description	Report that the I/O-0 HS switch has reach overtemperature threshold.
	Set / Reset condition	Set: I/O-0 HS switch thermal sensor above threshold. Reset: thermal sensor below threshold and flag read (SPI)
watchdog flash mode 50%	Description	Report that the watchdog period has reach 50% of its value, while device is in Flash mode.
	Set / Reset condition	Set: watchdog period > 50%. Reset: flag read
I/O-1-3 Wake-up	Description	Report that Wake-up source is I/O-1 or I/O-3
	Set / Reset condition	Set: after I/O-1 or I/O-3 wake detected. Reset: Flag read (SPI)
I/O-0-2 Wake-up	Description	Report that Wake-up source is I/O-0 or I/O-2
	Set / Reset condition	Set: after I/O-0 or I/O-2 wake detected. Reset: Flag read (SPI)
SPI Wake-up	Description	Report that Wake-up source is SPI command, in LP V _{DD} ON mode.
	Set / Reset condition	Set: after SPI Wake-up detected. Reset: Flag read (SPI)
FWU	Description	Report that Wake-up source is forced Wake-up
	Set / Reset condition	Set: after Forced Wake-up detected. Reset: Flag read (SPI)
INT service Timeout	Description	Report that INT timeout error detected.
	Set / Reset condition	Set: INT service timeout expired. Reset: flag read.
LP V _{DD} OFF	Description	Report that LP V _{DD} OFF mode was selected, prior Wake-up occurred.
	Set / Reset condition	Set: LP V _{DD} OFF selected. Reset: Flag read (SPI)
Reset request	Description	Report that RST source is an request from a SPI command (go to RST mode).
	Set / Reset condition	Set: After reset occurred due to SPI request. Reset: flag read (SPI)
Hardware Leave Debug	Description	Report that the device left the Debug mode due to hardware cause (voltage at DBG pin lower than typically 8.0 V).
	Set / Reset condition	Set: device leave debug mode due to hardware cause. Reset: flag read.

Table 40. Flag descriptions

Flag	Description	
INT		
INT request	Description	Report that INT source is an INT request from a SPI command.
	Set / Reset condition	Set: INT occurred. Reset: flag read (SPI)
RST high	Description	Report that RST pin is shorted to high voltage.
	Set / Reset condition	Set: RST failure detection. Reset: flag read.
DBG resistor	Description	Report that the resistor at DBG pin is different from expected (different from SPI register content).
	Set / Reset condition	Set: failure detected. Reset: correct resistor and flag read (SPI).
V _{DD} TEMP PRE-WARNING	Description	Report that the V _{DD} has reached overtemperature pre-warning threshold.
	Set / Reset condition	Set: V _{DD} thermal sensor above threshold. Reset: V _{DD} thermal sensor below threshold and flag read (SPI)
V _{DD} UV	Description	Reports that VDD pin is lower than the V _{DDUV} threshold.
	Set / Reset condition	Set: VDD below threshold for t >100 μs typically. Reset: V _{DD} above threshold and flag read (SPI)
V _{DD} overVOLTAGE	Description	Reports that VDD pin is higher than the typically V _{DD} + 0.6 V threshold. I/O-1 can be turned OFF if this function is selected in INIT register.
	Set / Reset condition	Set: VDD above threshold for t >100 μs typically. Reset: V _{DD} below threshold and flag read (SPI)
V _{AUX} _overVOLTAGE	Description	Reports that VAUX pin is higher than the typically V _{AUX} + 0.6 V threshold. I/O-1 can be turned OFF if this function is selected in INIT register.
	Set / Reset condition	Set: V _{AUX} above threshold for t >100 μs typically. Reset: V _{AUX} below threshold and flag read (SPI)
V _{DD} LOW >100 ms	Description	Reports that VDD pin is lower than the V _{DDUV} threshold for a time longer than 100 ms
	Set / Reset condition	Set: VDD below threshold for t >100 ms typically. Reset: V _{DD} above threshold and flag read (SPI)
V _{DD} LOW	Description	Report that V _{DD} is below V _{DD} undervoltage threshold.
	Set / Reset condition	Set: V _{DD} below threshold. Reset: flag read (SPI)
V _{DD} (5.0 V or 3.3 V)	Description	0: mean 3.3 V V _{DD} version 1: mean 5.0 V V _{DD} version
	Set / Reset condition	N/A
Device P/N1 and 0	Description	Describe the device part number: 00: MC33903 01: MC33904 10: MC33905S 11: MC33905D
	Set / Reset condition	N/A
Device id 4 to 0	Description	Describe the silicon revision number 10010: silicon revision A (Pass 3.1) 10011: silicon revision B (Pass 3.2) 10100: silicon revision C and D
	Set / Reset condition	N/A
RST low >100 ms	Description	Report that the RST pin has detected a low level, longer than 100 ms (Reset permanent low)
	Set / Reset condition	Set: after detection of reset low pulse. Reset: Reset pulse terminated and flag read (SPI)
Multiple Resets	Description	Report that the more than 8 consecutive reset pulses occurred, due to missing or wrong watchdog refresh.
	Set / Reset condition	Set: after detection of multiple reset pulses. Reset: flag read (SPI)
watchdog refresh failure	Description	Report that a wrong or missing watchdog failure occurred.
	Set / Reset condition	Set: failure detected. reset: flag read (SPI)

Table 40. Flag descriptions

Flag		Description
LIN/1/2		
LIN/1/2 bus dom clamp	Description	Report that the LIN/1/2 bus is dominant for a time longer than t_{DOM}
	Set / Reset condition	Set: Bus dominant clamp failure detected. Reset: failure recovered and flag read (SPI)
LIN/1/2 State	Description	Report real time LIN interface TXD/RXD mode. 1 if LIN is in TXD/RXD mode. 0 is LIN is not in TXD/RXD mode.
	Set / Reset condition	Set: LIN in TXD RXD mode. Reset: LIN not in TXD/RXD mode. LIN not in TXD/RXD mode by SPI command (ex LIN set in Sleep mode) or following a failure event (ex: TxL Dominant). Flag read SPI command (0x2780 or 0x2980) do not clear it, as it is 'real time' flag.
LIN/1/2 WU	Description	Report real time LIN Wake-up receiver state. 1 if LIN Wake-up is enable, 0 if LIN Wake-up is disable (means LIN signal will not be detected and will not Wake-up the device).
	Set / Reset condition	Set: LIN WU enable (LIN interface set in Sleep mode Wake-up enable). Reset: LIN Wake-up disable (LIN interface set in Sleep mode Wake-up disable). Flag read SPI command (0x2780 or 0x2980) do not clear the flag, as it is 'real time' information.
LIN/1/2 Wake-up	Description	Report that Wake-up source is LIN/1/2
	Set / Reset condition	Set: after LIN/1/2 wake detected. Reset: Flag read (SPI)
LIN/1/2 Term short to GND	Description	Report LIN/1/2 short to GND failure
	Set / Reset condition	Set: failure detected. Reset failure recovered and flag read (SPI)
LIN/1/2 overtemp	Description	Report that the LIN/1/2 interface has reach overtemperature threshold.
	Set / Reset condition	Set: LIN/1/2 thermal sensor above threshold. Reset: sensor below threshold and flag read (SPI)
RXD-L/1/2 low	Description	Report that RXD/1/2 pin is shorted to GND.
	Set / Reset condition	Set: RXD low failure detected. Reset: failure recovered and flag read (SPI)
RXD-L/1/2 high	Description	Report that RXD/1/2pin is shorted to recessive voltage.
	Set / Reset condition	Set: RXD high failure detected. Reset: failure recovered and flag read (SPI)
TXD-L/1/2 dom	Description	Report that TXD/1/2 pin is shorted to GND.
	Set / Reset condition	Set: TXD low failure detected. Reset: failure recovered and flag read (SPI)

10.4.2 Fix and extended device status

For every SPI command, the device response on MISO is fixed status information. This information is either:

Two Bytes

Fix Status + Extended Status: when a device write command is used (MOSI bits 15-14, bits C1 C0 = 01)

One Byte

Fix Status: when a device read operation is performed (MOSI bits 15-14, bits C1 C0 = 00 or 11).

Table 41. Status bits description

Bits	15	14	13	12	11	10	9	8	7	6	5	4	3	2	1	0
MISO	INT	WU	RST	CAN-G	LIN-G	I/O-G	SAFE-G	VREG-G	CAN-BUS	CAN-LOC	LIN2	LIN1	I/O-1	I/O-0	VREG-1	VREG-0

Bits	Description
INT	Indicates that an INT has occurred and that INT flags are pending to be read.
WU	Indicates that a Wake-up has occurred and that Wake-up flags are pending to be read.
RST	Indicates that a reset has occurred and that the flags that report the reset source are pending to be read.
CAN-G	The INT, WU, or RST source is CAN interface. CAN local or CAN bus source.
LIN-G	The INT, WU, or RST source is LIN2 or LIN1 interface
I/O-G	The INT, WU, or RST source is I/O interfaces.
SAFE-G	The INT, WU, or RST source is from a SAFE condition
VREG-G	The INT, WU, or RST source is from a Regulator event, or voltage monitoring event
CAN-LOC	The INT, WU, or RST source is CAN interface. CAN local source.
CAN-BUS	The INT, WU, or RST source is CAN interface. CAN bus source.

Bits	Description
LIN2	The INT, WU, or RST source is LIN2 interface
LIN/LIN1	The INT, WU, or RST source is LIN1 interface
I/O-0	The INT, WU, or RST source is I/O interface, flag from I/O sub address Low (bit 7 = 0)
I/O-1	The INT, WU, or RST source is I/O interface, flag from I/O sub address High (bit 7 = 1)
VREG-1	The INT, WU, or RST source is from a Regulator event, flag from REG register sub address high (bit 7 = 1)
VREG-0	The INT, WU, or RST source is from a Regulator event, flag from REG register sub address low (bit 7 = 0)

11 Typical applications

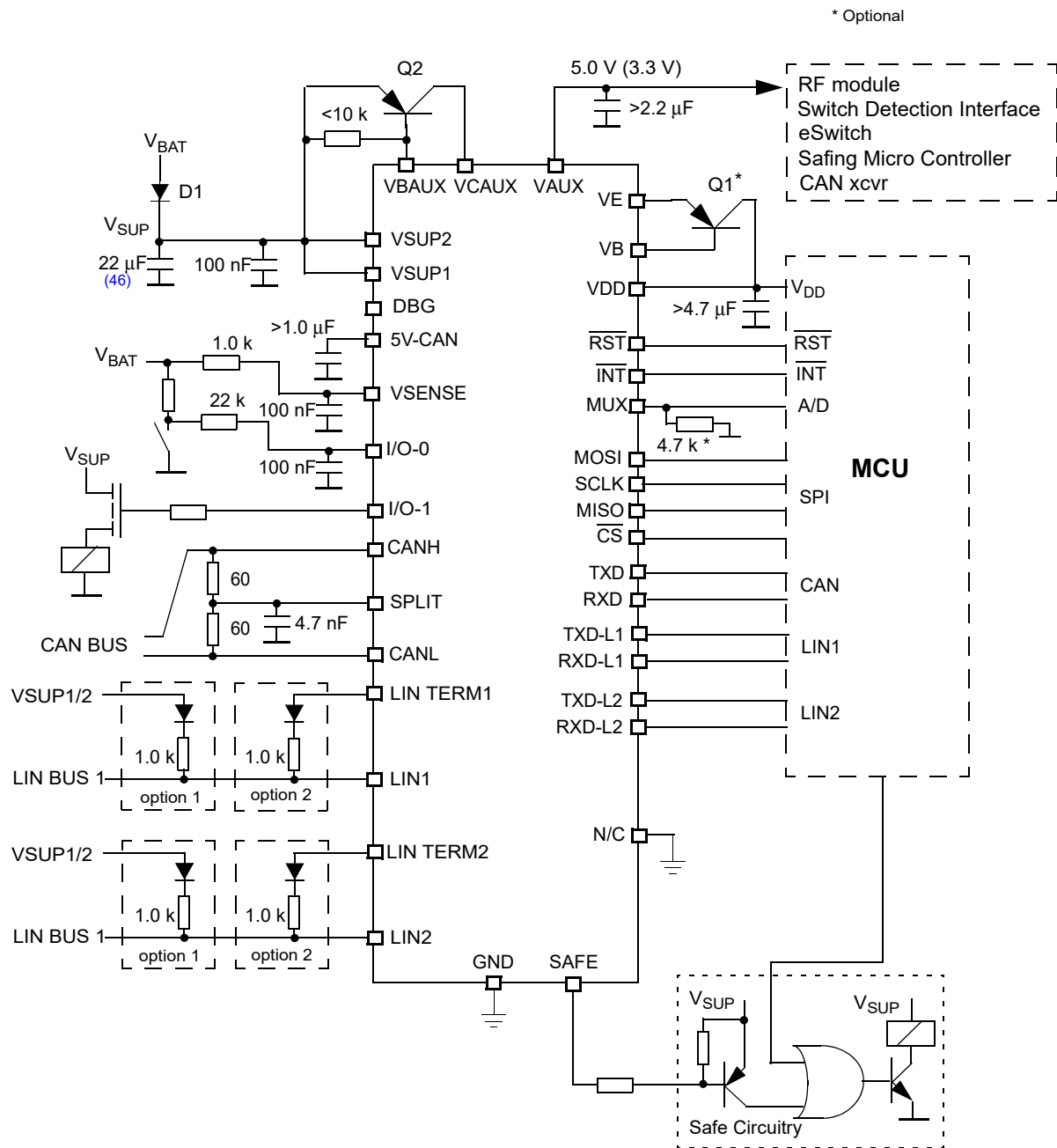

Notes

- 46. Tested per specific OEM EMC requirements for CAN and LIN with additional capacitor > 10 µF on V_SUP1/V_SUP2 pins

Figure 42. 33905D typical application schematic

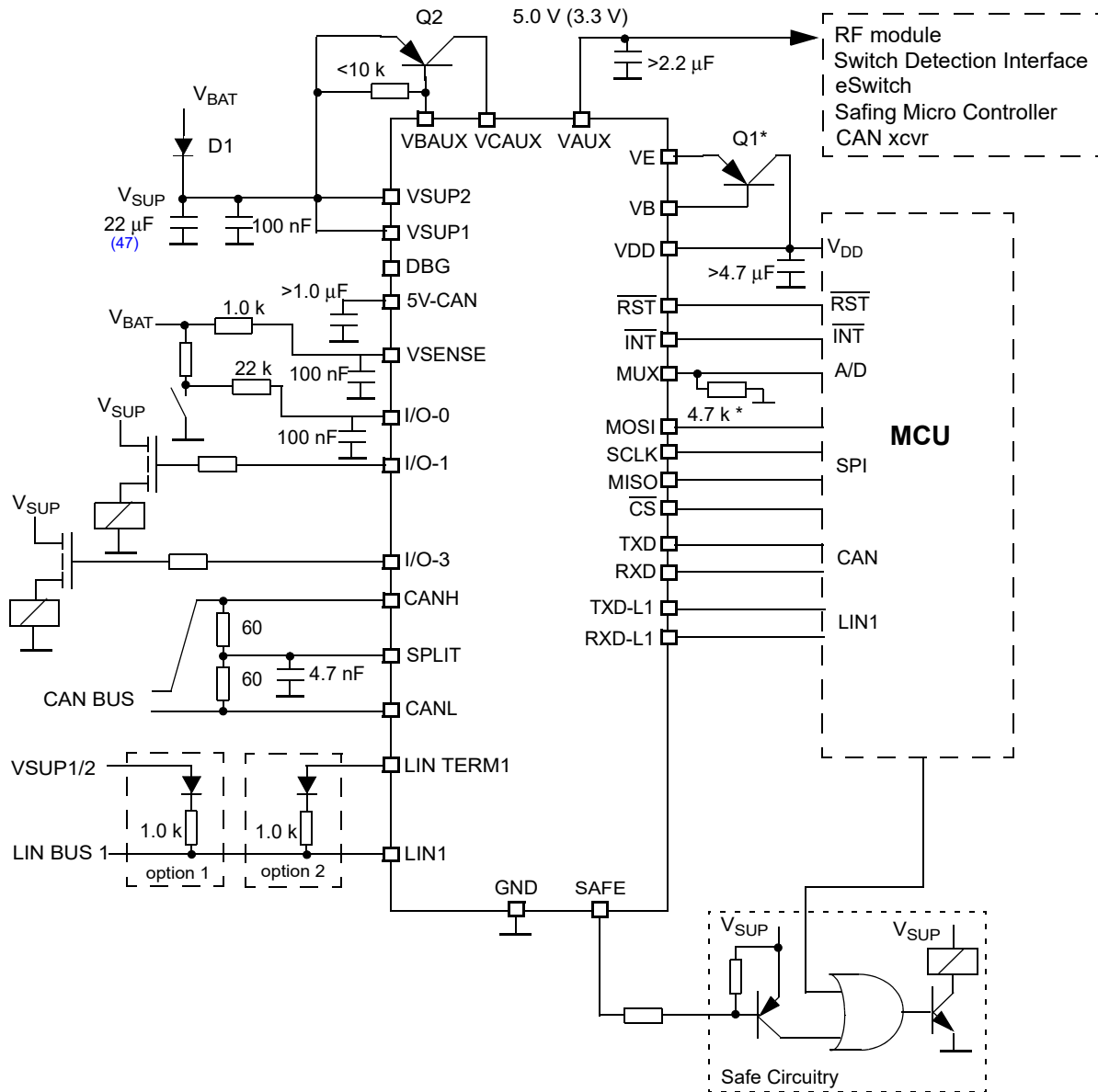

Notes

- 47. Tested per specific OEM EMC requirements for CAN and LIN with additional capacitor > 10 μF on VSUP1/VSUP2 pins

Figure 43. 33905S typical application schematic

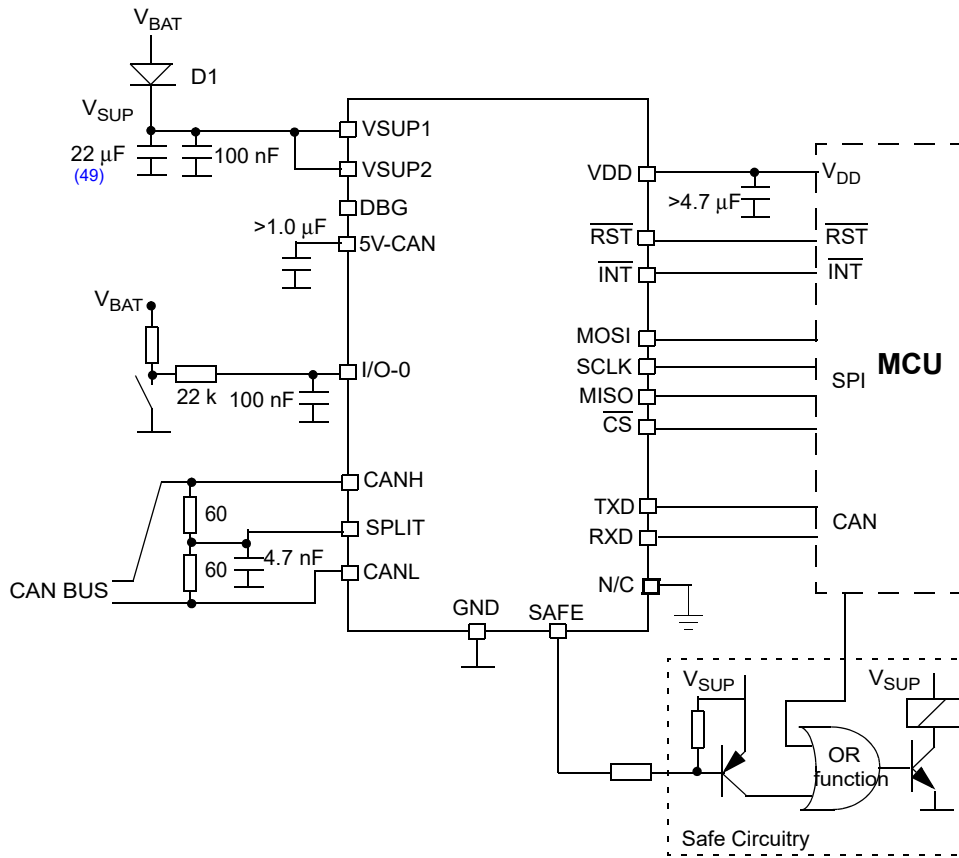

Notes

- 49. Tested per specific OEM EMC requirements for CAN and LIN with additional capacitor > 10 μF on VSUP1/VSUP2 pins

Figure 45. 33903 typical application schematic

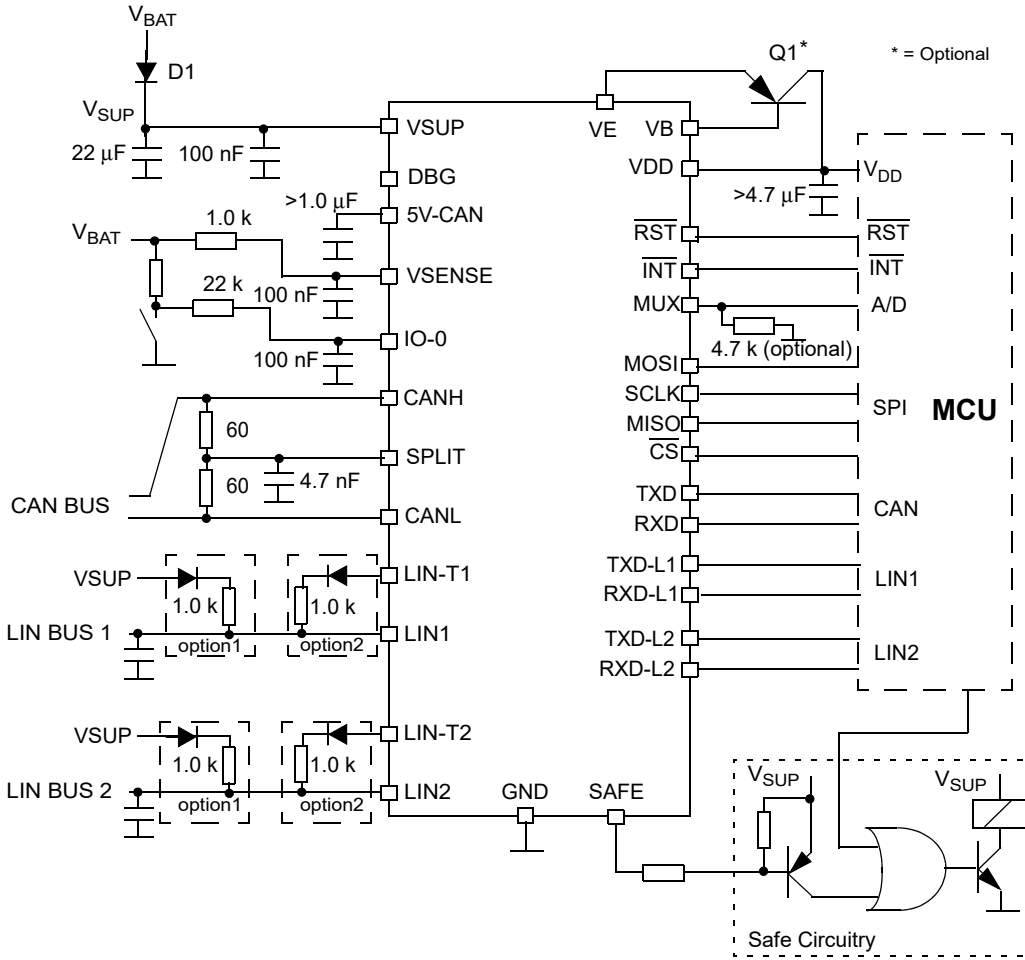

Notes

- 50. Tested per specific OEM EMC requirements for CAN and LIN with additional capacitor > 10 µF on VSUP pin

Figure 46. 33903D typical application schematic

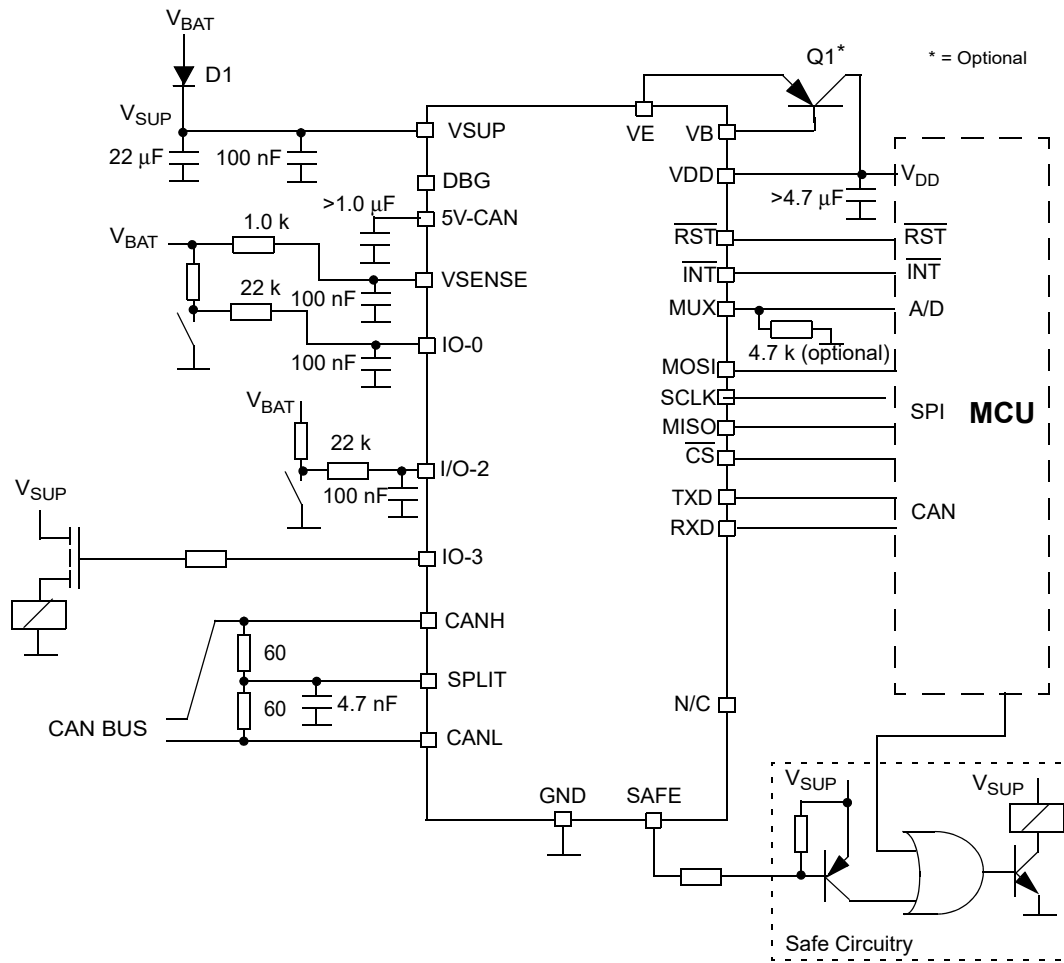

Notes

- 53. Tested per specific OEM EMC requirements for CAN and LIN with additional capacitor > 10 μ F on VSUP pin
- 54. Leave N/C pins open.

Figure 48. 33903P typical application schematic

The following figure illustrates the application case where two reverse battery diodes can be used for optimization of the filtering and buffering capacitor at the VDD pin. This allows using a minimum value capacitor at the VDD pin to guarantee reset-free operation of the MCU during the cranking pulse and temporary (50 ms) loss of the V_{BAT} supply.

Applications without an external ballast on V_{DD} and without using the VAUX regulator are illustrated as well.

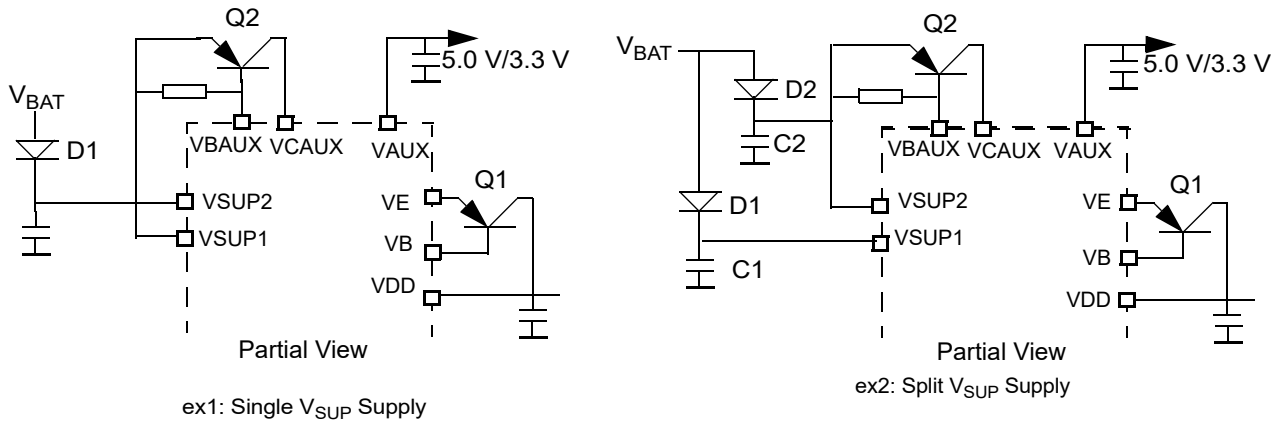

Optimized solution for cranking pulses.
C1 is sized for MCU power supply buffer only.

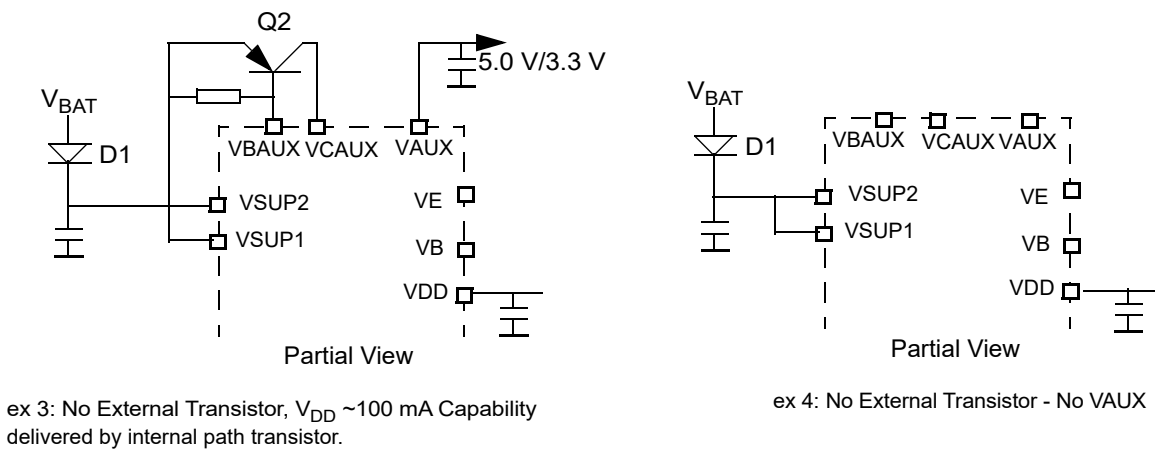
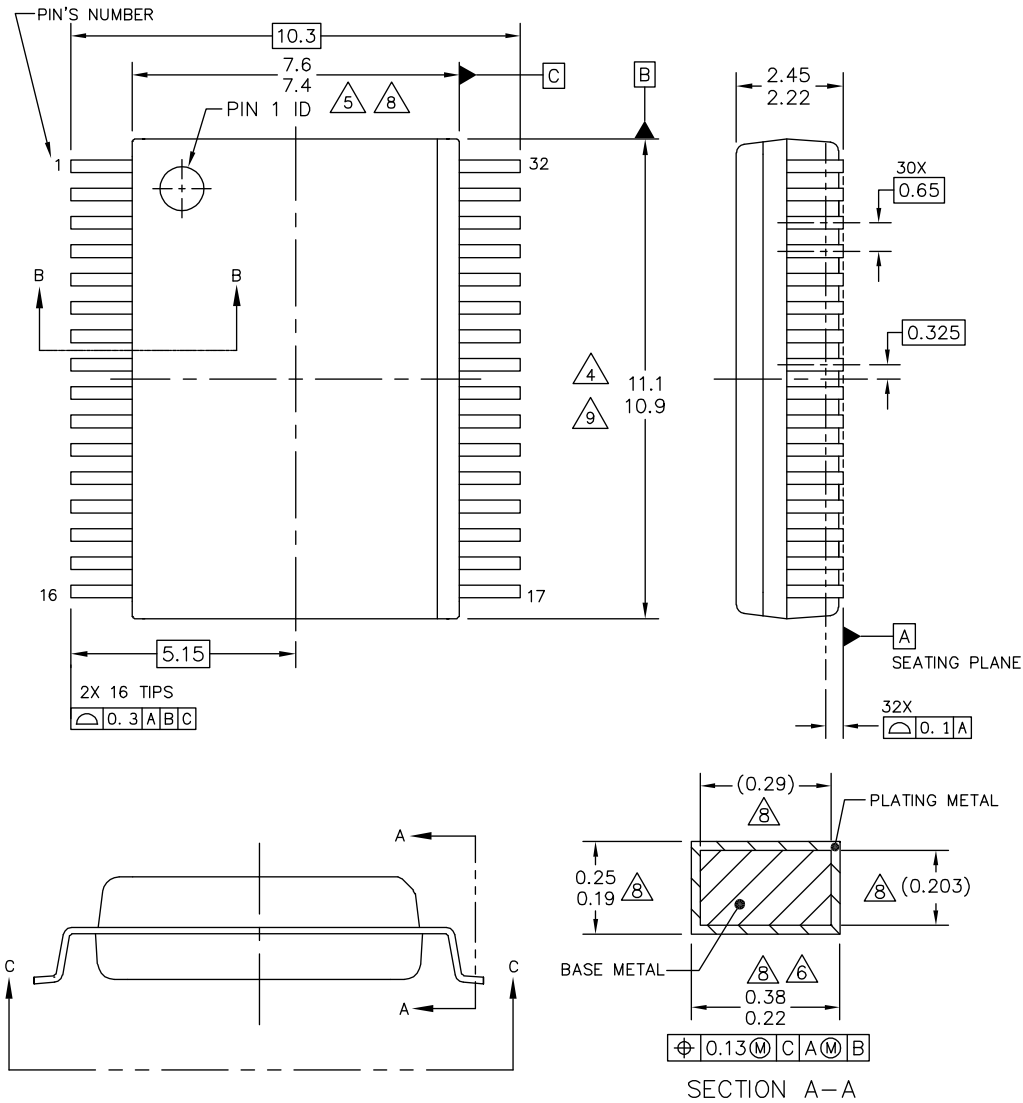

Figure 49. Application options

12 Packaging

12.1 SOIC 32 package dimensions

For the most current package revision, visit www.NXP.com and perform a keyword search using the "98A" listed below.



© NXP SEMICONDUCTORS N. V. ALL RIGHTS RESERVED	MECHANICAL OUTLINE	PRINT VERSION NOT TO SCALE
TITLE: 32LD SOIC W/B, 0.65 PITCH 4.7 X 4.7 EXPOSED PAD	DOCUMENT NO: 98ASA10556D	REV: F
	STANDARD: NON-JEDEC	
	SOT1746-3	15 JAN 2016

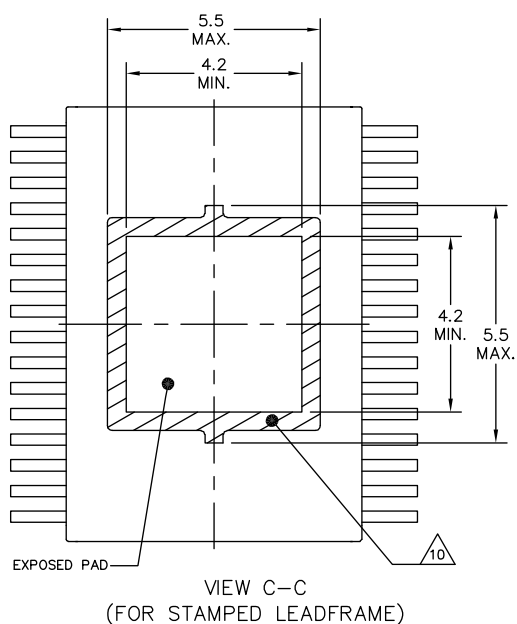
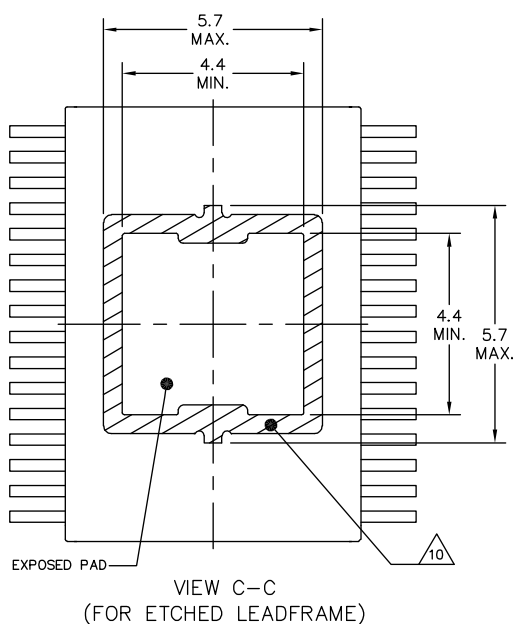
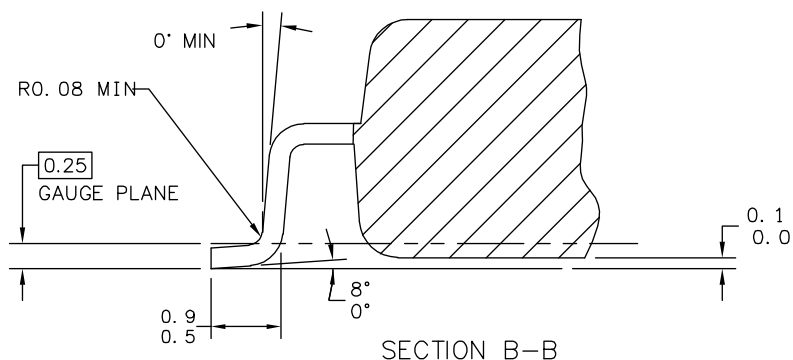

© NXP SEMICONDUCTORS N. V. ALL RIGHTS RESERVED	MECHANICAL OUTLINE	PRINT VERSION NOT TO SCALE
TITLE: 32LD SOIC W/B, 0.65 PITCH 4.7 X 4.7 EXPOSED PAD	DOCUMENT NO: 98ASA10556D	REV: F
	STANDARD: NON-JEDEC	
	SOT1746-3	15 JAN 2016



NOTES:

1. DIMENSIONS ARE IN MILLIMETERS.
2. DIMENSIONING AND TOLERANCING PER ASME Y14.5M-1994.
3. DATUMS B AND C TO BE DETERMINED AT THE PLANE WHERE THE BOTTOM OF THE LEADS EXIT THE PLASTIC BODY.
4. THIS DIMENSION DOES NOT INCLUDE MOLD FLASH, PROTRUSION OR GATE BURRS. MOLD FLASH, PROTRUSION OR GATE BURRS SHALL NOT EXCEED 0.15 MM PER SIDE. THIS DIMENSION IS DETERMINED AT THE PLANE WHERE THE BOTTOM OF THE LEADS EXIT THE PLASTIC BODY.
5. THIS DIMENSION DOES NOT INCLUDE INTER-LEAD FLASH OR PROTRUSIONS. INTER-LEAD FLASH AND PROTRUSIONS SHALL NOT EXCEED 0.25 MM PER SIDE. THIS DIMENSION IS DETERMINED AT THE PLANE WHERE THE BOTTOM OF THE LEADS EXIT THE PLASTIC BODY.
6. THIS DIMENSION DOES NOT INCLUDE DAMBAR PROTRUSION. ALLOWABLE DAMBAR PROTRUSION SHALL NOT CAUSE THE LEAD WIDTH TO EXCEED 0.4 mm. DAMBAR CANNOT BE LOCATED ON THE LOWER RADIUS OR THE FOOT. MINIMUM SPACE BETWEEN PROTRUSION AND ADJACENT LEAD SHALL NOT LESS THAN 0.07 mm.
7. EXACT SHAPE OF EACH CORNER IS OPTIONAL.
8. THESE DIMENSIONS APPLY TO THE FLAT SECTION OF THE LEAD BETWEEN 0.10 mm AND 0.3 mm FROM THE LEAD TIP.
9. THE PACKAGE TOP MAY BE SMALLER THAN THE PACKAGE BOTTOM. THIS DIMENSION IS DETERMINED AT THE OUTERMOST EXTREMES OF THE PLASTIC BODY EXCLUSIVE OF MOLD FLASH, TIE BAR BURRS, GATE BURRS AND INTER-LEAD FLASH, BUT INCLUDING ANY MISMATCH BETWEEN THE TOP AND BOTTOM OF THE PLASTIC BODY.
10. HATCHED AREA TO BE KEEP-OUT ZONE FOR PCB ROUTING.

© NXP SEMICONDUCTORS N. V. ALL RIGHTS RESERVED	MECHANICAL OUTLINE	PRINT VERSION NOT TO SCALE
TITLE: 32LD SOIC W/B, 0.65 PITCH 4.7 X 4.7 EXPOSED PAD	DOCUMENT NO: 98ASA10556D	REV: F
	STANDARD: NON-JEDEC	
	SOT1746-3	15 JAN 2016

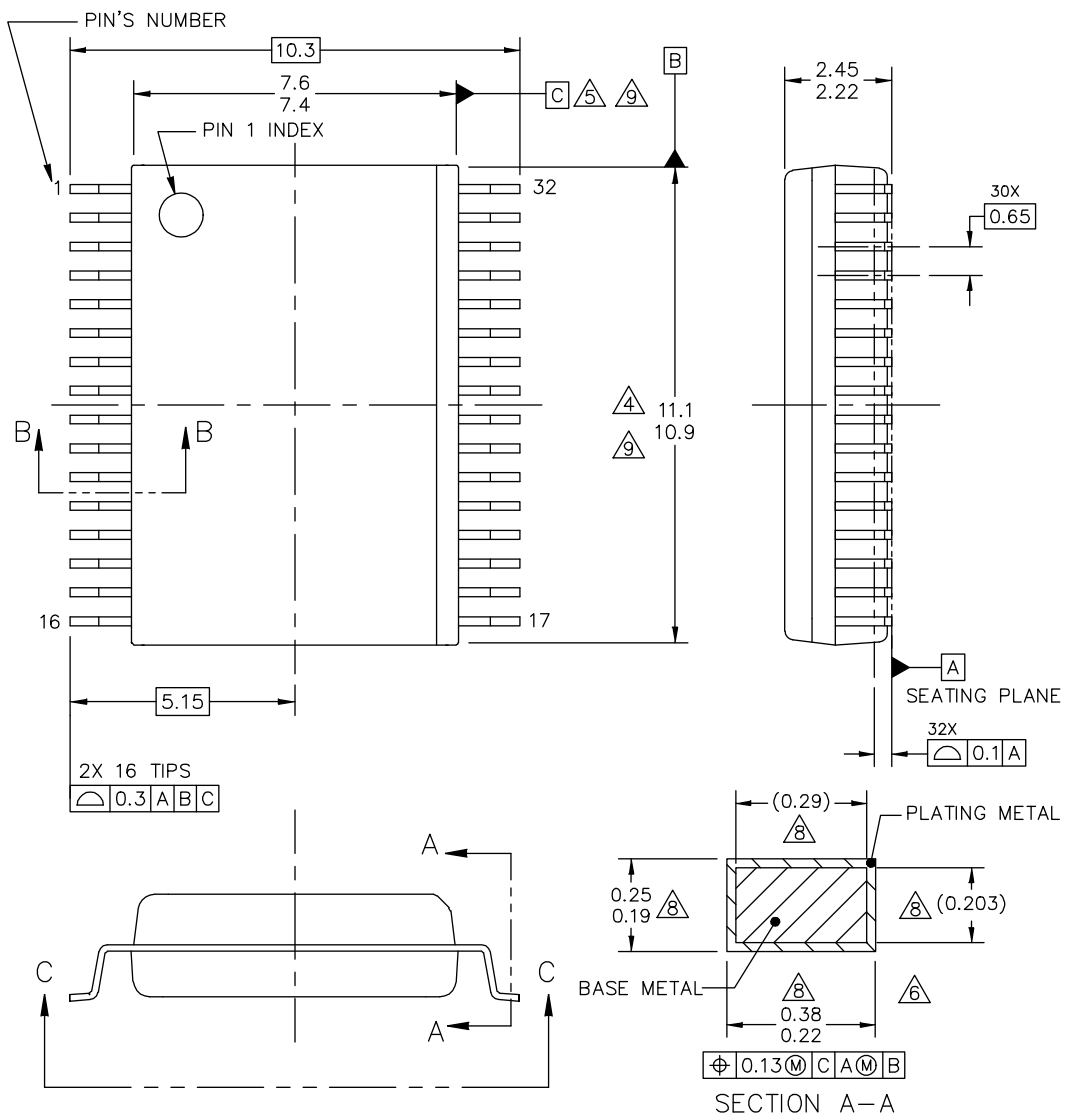

TITLE: 32LD SOIC W/B, 0.65 PITCH 4.6 X 4.6 EXPOSED PAD	DOCUMENT NO: 98ASA00259D	REV: B
	STANDARD: NON-JEDEC	
	SOT1762-2	

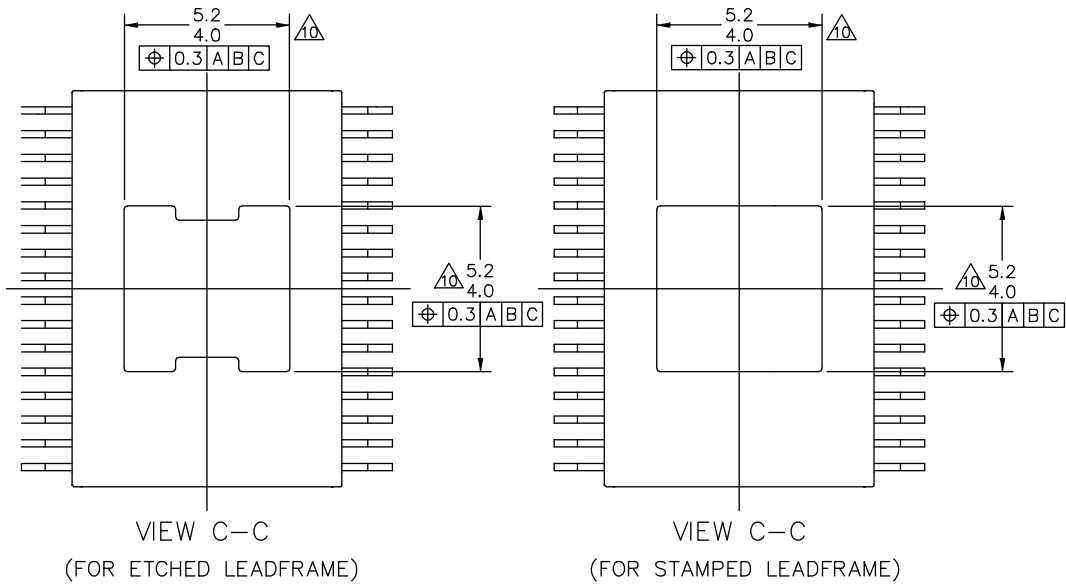
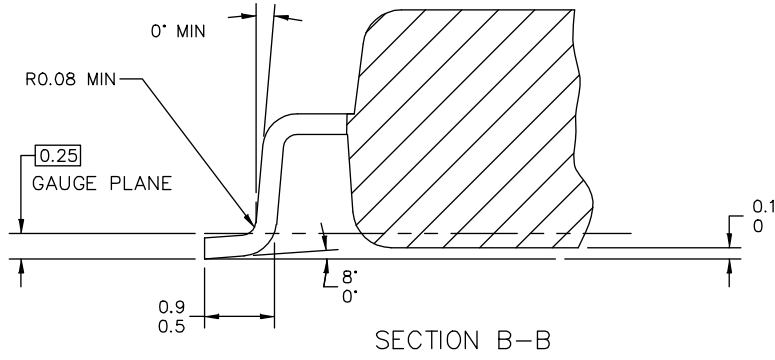

TITLE: 32LD SOIC W/B, 0.65 PITCH 4.6 X 4.6 EXPOSED PAD	DOCUMENT NO: 98ASA00259D	REV: B
	STANDARD: NON-JEDEC	
	SOT1762-2	

NOTES:

1. DIMENSIONS ARE IN MILLIMETERS.
2. DIMENSIONING AND TOLERANCING PER ASME Y14.5M-1994.
3. DATUMS B AND C TO BE DETERMINED AT THE PLANE WHERE THE BOTTOM OF THE LEADS EXIT THE PLASTIC BODY.
4. THIS DIMENSION DOES NOT INCLUDE MOLD FLASH, PROTRUSION OR GATE BURRS. MOLD FLASH, PROTRUSION OR GATE BURRS SHALL NOT EXCEED 0.15 MM PER SIDE. THIS DIMENSION IS DETERMINED AT THE PLANE WHERE THE BOTTOM OF THE LEADS EXIT THE PLASTIC BODY.
5. THIS DIMENSION DOES NOT INCLUDE INTER-LEAD FLASH OR PROTRUSIONS. INTER-LEAD FLASH AND PROTRUSIONS SHALL NOT EXCEED 0.25 MM PER SIDE. THIS DIMENSION IS DETERMINED AT THE PLANE WHERE THE BOTTOM OF THE LEADS EXIT THE PLASTIC BODY.
6. THIS DIMENSION DOES NOT INCLUDE DAMBAR PROTRUSION. ALLOWABLE DAMBAR PROTRUSION SHALL NOT CAUSE THE LEAD WIDTH TO EXCEED 0.4 mm. DAMBAR CANNOT BE LOCATED ON THE LOWER RADIUS OR THE FOOT. MINIMUM SPACE BETWEEN PROTRUSION AND ADJACENT LEAD SHALL NOT LESS THAN 0.07 mm.
7. EXACT SHAPE OF EACH CORNER IS OPTIONAL.
8. THESE DIMENSIONS APPLY TO THE FLAT SECTION OF THE LEAD BETWEEN 0.10 mm AND 0.3 mm FROM THE LEAD TIP.
9. THE PACKAGE TOP MAY BE SMALLER THAN THE PACKAGE BOTTOM. THIS DIMENSION IS DETERMINED AT THE OUTERMOST EXTREMES OF THE PLASTIC BODY EXCLUSIVE OF MOLD FLASH, TIE BAR BURRS, GATE BURRS AND INTER-LEAD FLASH, BUT INCLUDING ANY MISMATCH BETWEEN THE TOP AND BOTTOM OF THE PLASTIC BODY.
10. THESE DIMENSION RANGES DEFINE THE PRIMARY PCB KEEP-OUT AREA. MOLD LOCKING FEATURES MAY BE EXTENDED 0.7MM FROM MAXIMUM EXPOSED PAD SIZE.

TITLE: 32LD SOIC W/B, 0.65 PITCH 4.6 X 4.6 EXPOSED PAD	DOCUMENT NO: 98ASA00259D REV: B
	STANDARD: NON-JEDEC
	SOT1762-2

12.2 SOIC 54 package dimensions

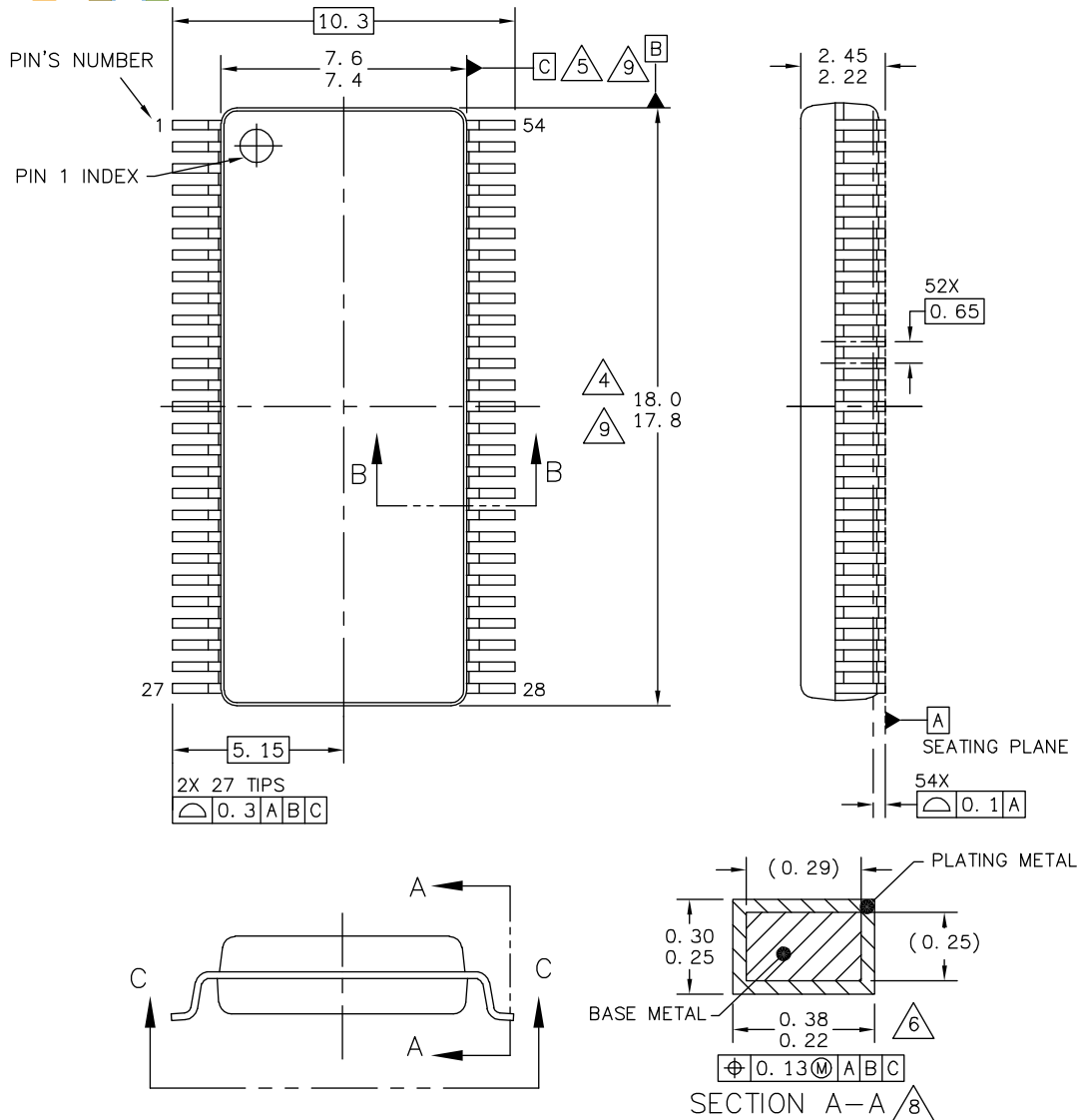

© NXP SEMICONDUCTORS N. V. ALL RIGHTS RESERVED	MECHANICAL OUTLINE	PRINT VERSION NOT TO SCALE
TITLE: 54LD SOIC W/B, 0.65 PITCH 4.6 X 4.6 EXPOSED PAD, CASE-OUTLINE	DOCUMENT NO: 98ASA10506D	REV: E
	STANDARD: NON-JEDEC	
	SOT1747-3	10 MAR 2016

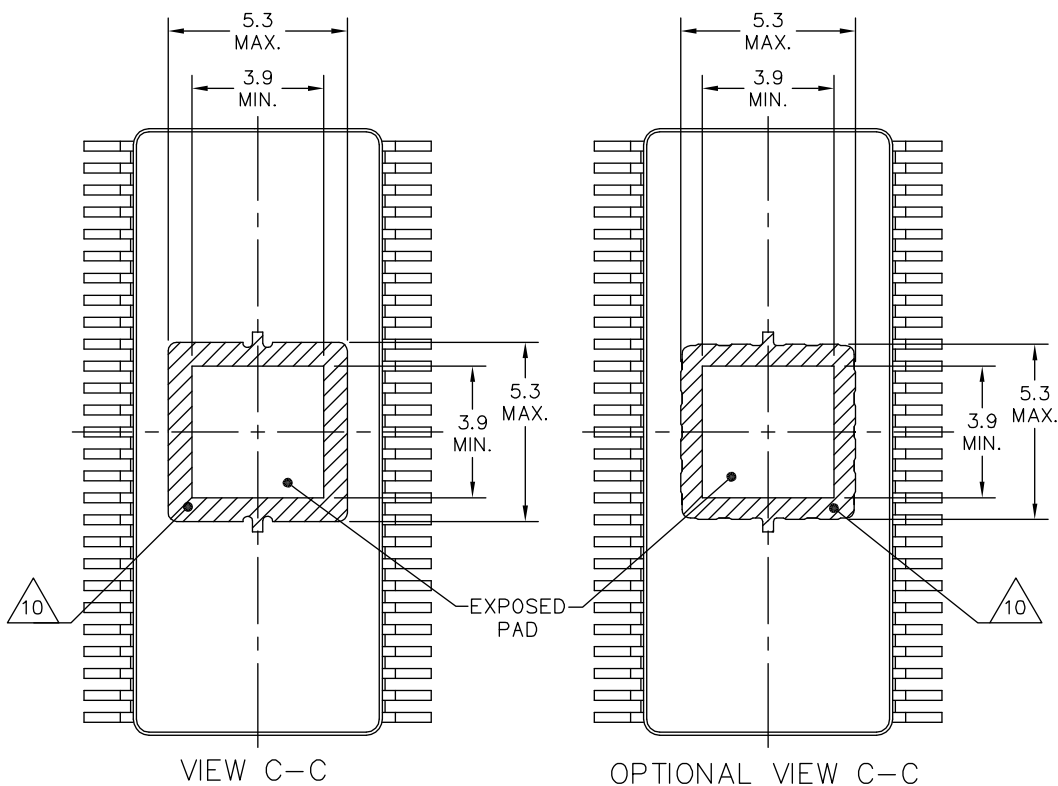
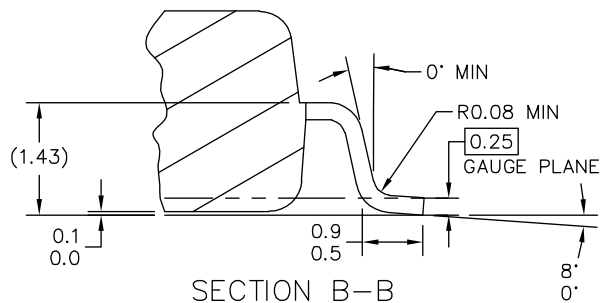

© NXP SEMICONDUCTORS N. V. ALL RIGHTS RESERVED	MECHANICAL OUTLINE	PRINT VERSION NOT TO SCALE
TITLE: 54LD SOIC W/B, 0.65 PITCH 4.6 X 4.6 EXPOSED PAD, CASE-OUTLINE	DOCUMENT NO: 98ASA10506D	REV: E
	STANDARD: NON-JEDEC	
	SOT1747-3	10 MAR 2016



NOTES:

1. DIMENSIONS ARE IN MILLIMETERS.
2. DIMENSIONING AND TOLERANCING PER ASME Y14.5M-1994.
3. DATUMS B AND C TO BE DETERMINED AT THE PLANE WHERE THE BOTTOM OF THE LEADS EXIT THE PLASTIC BODY.
4. THIS DIMENSION DOES NOT INCLUDE MOLD FLASH, PROTRUSION OR GATE BURRS. MOLD FLASH, PROTRUSION OR GATE BURRS SHALL NOT EXCEED 0.15 mm PER SIDE. THIS DIMENSION IS DETERMINED AT THE PLANE WHERE THE BOTTOM OF THE LEADS EXIT THE PLASTIC BODY.
5. THIS DIMENSION DOES NOT INCLUDE INTER-LEAD FLASH OR PROTRUSIONS. INTER-LEAD FLASH AND PROTRUSIONS SHALL NOT EXCEED 0.25 mm PER SIDE. THIS DIMENSION IS DETERMINED AT THE PLANE WHERE THE BOTTOM OF THE LEADS EXIT THE PLASTIC BODY.
6. THIS DIMENSION DOES NOT INCLUDE DAMBAR PROTRUSION. ALLOWABLE DAMBAR PROTRUSION SHALL NOT CAUSE THE LEAD WIDTH TO EXCEED 0.46 mm. DAMBAR CANNOT BE LOCATED ON THE LOWER RADIUS OR THE FOOT. MINIMUM SPACE BETWEEN PROTRUSION AND ADJACENT LEAD SHALL NOT BE LESS THAN 0.07 mm.
7. EXACT SHAPE OF EACH CORNER IS OPTIONAL.
8. THESE DIMENSIONS APPLY TO THE FLAT SECTION OF THE LEAD BETWEEN 0.1 mm AND 0.3 mm FROM THE LEAD TIP.
9. THE PACKAGE TOP MAY BE SMALLER THAN THE PACKAGE BOTTOM. THIS DIMENSION IS DETERMINED AT THE OUTERMOST EXTREMES OF THE PLASTIC BODY EXCLUSIVE OF MOLD FLASH, TIE BAR BURRS, GATE BURRS AND INTER-LEAD FLASH, BUT INCLUDING ANY MISMATCH BETWEEN THE TOP AND BOTTOM OF THE PLASTIC BODY.
10. HATCHED AREA TO BE KEEP-OUT ZONE FOR PCB ROUTING.

© NXP SEMICONDUCTORS N. V. ALL RIGHTS RESERVED	MECHANICAL OUTLINE	PRINT VERSION NOT TO SCALE	
TITLE: 54LD SOIC W/B, 0.65 PITCH 4.6 X 4.6 EXPOSED PAD, CASE-OUTLINE		DOCUMENT NO: 98ASA10506D	REV: E
		STANDARD: NON-JEDEC	
		SOT1747-3	10 MAR 2016

13 Revision history

Revision	Date	Description of changes
4.0	9/2010	<ul style="list-style-type: none"> Initial Release - This document supersedes document MC33904_5. Initial release of document includes the MC33903 part number, the VDD 3.3 V version description, and the silicon revision rev. 3.2. Change details available upon request.
5.0	12/2010	<ul style="list-style-type: none"> Added 7.9. Cyclic INT operation during LP VDD on mode 47 Changed VSUP pin to VSUP1 and pin 2 (NC) to VSUP2 for the 33903 device Removed . Drop voltage without external PNP pass transistor 19 for $V_{DD}=3.3$ V devices Added $V_{SUP1-3.3}$ to . VDD Voltage regulator, VDD pin 19. Added . Pull-up Current, TXD, VIN = 0 V 23 for $V_{DD}=3.3$ V devices Revised 10.3.1. MUX and RAM registers 68 Revised 41. Status bits description 90 Added 10.3.5.2. Entering into LP mode using random code 77.
6.0	4/2011	<ul style="list-style-type: none"> Removed part numbers MCZ33905S3EK/R2, MCZ33904A3EK/R2 and MCZ33905D3EK/R2, and added part numbers MCZ33903BD3EK/R2, MCZ33903BD5EK/R2, MCZ33903BS3EK/R2 and MCZ33903BS5EK/R2. Voltage Supply was improved from 27V to 28V. Changed Classification from Advance Information to Technical Data. Updated Notes in Table 8. Revised Table 8; Attenuation/Gain ratio for I/O-0 and I/O-1 actual voltage: to reflect a Typical value. Corrected typographical errors throughout. Added Chip temperature: MUX-OUT voltage (guaranteed by design and characterization) parameter to Table 8. Updated I/O pins (I/O-0: I/O-3) on page 33.
7.0	9/2011	<ul style="list-style-type: none"> Updated vOUT-5.0-EMC maximum Updated t_{LEAD} parameter Added t_{CSLOW} parameter Updated the Detail operation section to reflect the importance of acknowledging t_{LEAD} and t_{CSLOW}. Corrected typographical error in Table 34 CAN REGISTER for Slew Rate bits b5,b4
8.0	1/2011	<ul style="list-style-type: none"> Added 12 PCZ devices to the ordering information Bit label change on Table 39 from INT to SAFE Revised notes on Table 1 to include "C" version Split Falling Edge of CS to Rising Edge of SCLK to differentiate the "C" version Added "C" version note to Table 39 and Table 40 Added device ID 10100 Rev C, Pass 3.3 to Device id 4 to 0 Added Debug mode DBG voltage range parameter. Already detailed in text. Added the MC33903P device, making additions throughout the document, where applicable.
9.0	2/2012	<ul style="list-style-type: none"> Changed all PC devices to MC devices.
	4/2013	<ul style="list-style-type: none"> No technical changes. Revised back page. Updated document properties. Added SMARTMOS sentence to first paragraph.
10.0	2/2014	<ul style="list-style-type: none"> Added package type in Table 1. Added new parameter to Output Voltage on page 19 for VDD Added ⁽¹⁴⁾ Updated section 7.5.2.2. Watchdog in debug mode 40. Replaced "set" by "left".
11.0	8/2014	<ul style="list-style-type: none"> Changed t_{CS_TO} in the Dynamic electrical characteristics from 2.5 to 2.0 Note added to MUX-output (MUXOUT) on page 33 of Functional pin description Added a paragraph in the SPI Detail operation section for the maximum t_{LEAD} time in case the 'CSB low' flag is set Added maximum t_{LEAD} time in case the 'CSB low' flag is set to 1 in the Dynamic electrical characteristics table
12.0	8/2016	<ul style="list-style-type: none"> Updated as per CIN 201608012I Added 'D' version orderable part numbers to Table 1, Table 2, and Table 3 Updated note ⁽²⁾, ⁽⁵⁾, ⁽⁹⁾ Added note ⁽²⁾, ⁽⁶⁾, ⁽¹⁰⁾ ('C' versions are no longer recommended for new design) to Table 1, Table 2, and Table 3 Added reference to 'D' version in the document where applicable Updated flag description for device id 4 to 0 in Table 40 Updated to NXP document format and style
13.0	5/2017	<ul style="list-style-type: none"> Updated Figure 29 to include 3.3 V information Updated workflow step 3 in Figure 30 (SPI commands: changed 0xDD00 to 0x1D80) Updated bit 1 description in Table 32

REVISION HISTORY

Revision	Date	Description of changes
14.0	2/2018	<ul style="list-style-type: none"> Updated note ⁽⁷⁾ (deleted "Output current limited to 100 mA") Updated values for $V_{RST-VTH}$ in Table 6 as per CIN 201712019I <ul style="list-style-type: none"> Removed typ. and max. values for $V_{RST-VTH}$ (Low threshold, $V_{DD} = 5.0$ V) Removed min. and typ. values for $V_{RST-VTH}$ (High threshold, $V_{DD} = 5.0$ V) Removed typ. and max. values for $V_{RST-VTH}$ (Low threshold, $V_{DD} = 3.3$ V) Removed min. and typ. values for $V_{RST-VTH}$ (High threshold, $V_{DD} = 3.3$ V)
15.0	6/2023	<ul style="list-style-type: none"> Revised "98ASA10556D" to "98ASA10556D/98ASA00259D" for the 32-PIN SOIC Table 1: revised as follows: <ul style="list-style-type: none"> Removed footnote references 1, 2, and 3 from the Version column and removed the footnotes from the last row of the table. Removed the following part numbers from the table: MCZ33905BD3EK/R2, MCZ33905CD3EK/R2, MCZ33905D5EK/R2, MCZ33905BD5EK/R2, MCZ33905CD5EK/R2, MCZ33905BS3EK/R2, MCZ33905CS3EK/R2, MCZ33905S5EK/R2, MCZ33905BS5EK/R2, MCZ33905CS5EK/R2. Inserted "SOT1747-3" and "SOT1746-3" the to the package column. Table 2: revised as follows: <ul style="list-style-type: none"> Removed footnote references 4, 5, and 6 from the Version column and removed the footnotes from the last row of the table. Removed the following part numbers from the table: MCZ33904B3EK/R2, MCZ33904C3EK/R2, MCZ33904A5EK/R2, MCZ33904B5EK/R2, and MCZ33904C5EK/R2. Inserted "SOT1747-3" and "SOT1746-3" the to the package column. Table 3: revised as follows: <ul style="list-style-type: none"> Removed footnote references 8, 9, and 10 from the Version column and removed the footnotes from the last row of the table. Removed the following part numbers from the table: MCZ33903B3EK/R2, MCZ33903C3EK/R2, MCZ33903B5EK/R2, MCZ33903C5EK/R2, MCZ33903BD3EK/R2, MCZ33903CD3EK/R2, MCZ33903BD5EK/R2, MCZ33903CD5EK/R2, MCZ33903BS3EK/R2, MCZ33903CS3EK/R2, MCZ33903BS5EK/R2, MCZ33903CS5EK/R2, MCZ33903CP5EK/R2, and MCZ33903CP3EK/R2. Inserted "SOT1746-3" and "SOT1762-2" the to the package column. Inserted new footnote in Version column. Inserted new footnote in the V_{DD} output voltage column. Footnote 1: Added "The 'C' versions are no longer recommended for new designs. The 'D' versions are recommended for new designs, and include quality improvements, and have no electrical parameters specification changes." to the end of the footnote. Table 4: revised "MC33903BDEK and MC33903BSEK" to "33903D, 33903S, and 33903P" in pin rows 4 and 5. Table 5: updated the footnote number applied to this table. Table 6: revised "MC33903BDEK and MC33903BSEK" to "33903D, 33903S, and 33903P" in the last footnote. Section 12.1: inserted package drawing for 98ASA00259D.

How to Reach Us:**Home Page:**[NXP.com](http://www.nxp.com)**Web Support:**<http://www.nxp.com/support>

Information in this document is provided solely to enable system and software implementers to use NXP products.

There are no expressed or implied copyright licenses granted hereunder to design or fabricate any integrated circuits based on the information in this document. NXP reserves the right to make changes without further notice to any products herein.

NXP makes no warranty, representation, or guarantee regarding the suitability of its products for any particular purpose, nor does NXP assume any liability arising out of the application or use of any product or circuit, and specifically disclaims any and all liability, including without limitation, consequential or incidental damages. "Typical" parameters that may be provided in NXP data sheets and/or specifications can and do vary in different applications, and actual performance may vary over time. All operating parameters, including "typicals," must be validated for each customer application by the customer's technical experts. NXP does not convey any license under its patent rights nor the rights of others. NXP sells products pursuant to standard terms and conditions of sale, which can be found at the following address:

<http://www.nxp.com/terms-of-use.html>.

NXP, the NXP logo, Freescale, the Freescale logo and SMARTMOS are trademarks of NXP B.V. All other product or service names are the property of their respective owners. All rights reserved.

© NXP B.V. 2010-2023.

Document Number: MC33903_4_5

Rev. 15.0

6/2023



Looking for pricing, stock, or lifecycle information?

Click below to explore more details on WIN SOURCE:

 [View MCZ33903DP5EKR2 on WIN SOURCE](#)

 [NXP / Nexperia Information](#)

Optimize Your Supply Chain with WIN SOURCE Solutions

-  Global Sourcing Solution
-  Obsolete Management
-  Cost Control Management
-  Shortage Management
-  Alternative Solution
-  Excess Inventory Management