



**THE DATASHEET OF  
BGA416E6327HTSA1**



# BGA416

RF Cascode Amplifier

Small Signal Discretes



Never stop thinking

**Edition 2008-04-21**

**Published by Infineon Technologies AG,  
81726 München, Germany**

**© Infineon Technologies AG 2008.  
All Rights Reserved.**

**Attention please!**

The information herein is given to describe certain components and shall not be considered as a guarantee of characteristics.

Terms of delivery and rights to technical change reserved.

We hereby disclaim any and all warranties, including but not limited to warranties of non-infringement, regarding circuits, descriptions and charts stated herein.

**Information**

For further information on technology, delivery terms and conditions and prices please contact your nearest Infineon Technologies Office ([www.infineon.com](http://www.infineon.com)).

**Warnings**

Due to technical requirements components may contain dangerous substances. For information on the types in question please contact your nearest Infineon Technologies Office.

Infineon Technologies Components may only be used in life-support devices or systems with the express written approval of Infineon Technologies, if a failure of such components can reasonably be expected to cause the failure of that life-support device or system, or to affect the safety or effectiveness of that device or system. Life support devices or systems are intended to be implanted in the human body, or to support and/or maintain and sustain and/or protect human life. If they fail, it is reasonable to assume that the health of the user or other persons may be endangered.

---

**BGA416, RF Cascode Amplifier****Revision History: 2008-04-21, Rev. 2.1****Previous Version: 2005-07-26**

<b>Page</b>	<b>Subjects (major changes since last revision)</b>
All	Document layout change
4-5	Electrical Characteristics slightly changed
7-8	Figures updated

**Trademarks**SIEGET<sup>®</sup> is a registered trademark of Infineon Technologies AG.

# 1 RF Cascode Amplifier

## Feature

- $G_{MA} = 23$  dB at 900 MHz
- Ultra high reverse isolation, 60 dB at 900 MHz
- Low noise figure,  $F_{50\Omega} = 1.2$  dB at 900 MHz
- On chip bias circuitry, 5.5 mA bias current at  $V_{CC} = 3$  V
- Typical supply voltage: 2.5 to 5.0 V
- SIEGET<sup>®</sup>-25 technology
- Pb-free (RoHS compliant) package

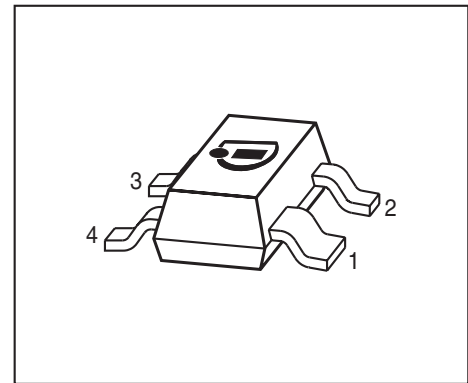

SOT143

## Applications

- Buffer amplifier
- LNAs
- Oscillator active devices

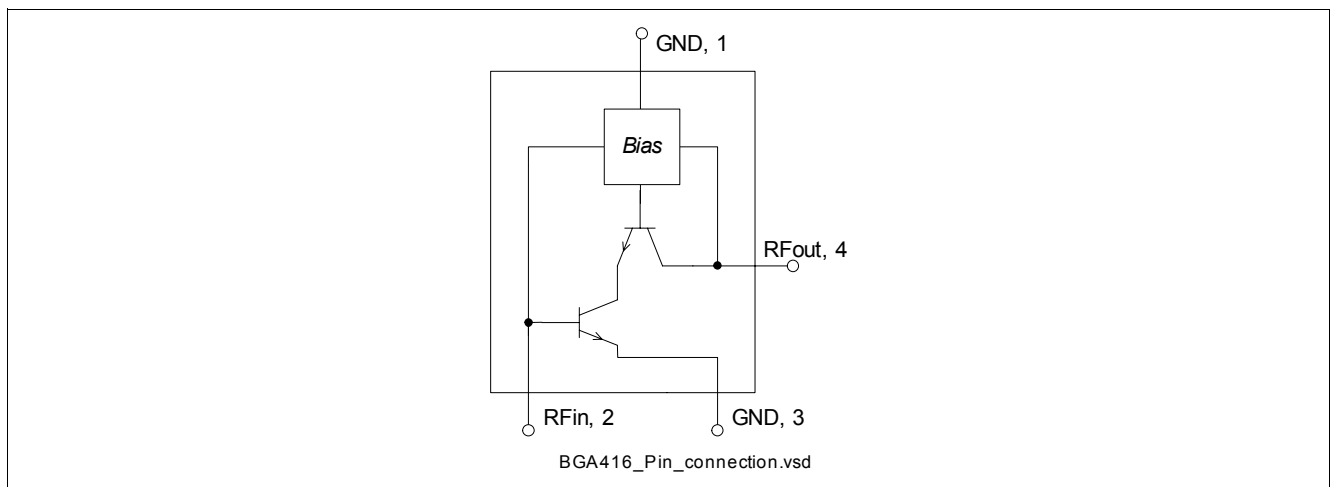

Figure 1 Pin connection

## Description

BGA416 is a monolithic silicon cascode amplifier with high reverse isolation. A bias network is integrated for simplified biasing.

Type	Package	Marking
BGA416	SOT143	C1s

Note: **ESD**: Electrostatic discharge sensitive device, observe handling precaution

## Maximum Ratings

**Table 1 Maximum ratings**

Parameter	Symbol	Limit Value	Unit
Voltage at pin RFout	$V_{OUT}$	6	V
Device current <sup>1)</sup>	$I_D$	20	mA
Current into pin RFin	$I_{in}$	0.5	mA
Input power	$P_{in}$	8	dBm
Total power dissipation, $T_S < 123^\circ\text{C}^{2)}$	$P_{tot}$	100	mW
Junction temperature	$T_J$	150	$^\circ\text{C}$
Ambient temperature range	$T_A$	-65... 150	$^\circ\text{C}$
Storage temperature range	$T_{STG}$	-65... 150	$^\circ\text{C}$

1) Device current is equal to current into pin RFout

2)  $T_S$  is measured on the ground lead at the soldering point

Note: All Voltages refer to GND-Node

## Thermal resistance

**Table 2 Thermal resistance**

Parameter	Symbol	Value	Unit
Junction - soldering point <sup>1)</sup>	$R_{thJS}$	270	K/W

1) For calculation of  $R_{thJA}$  please refer to Application Note Thermal Resistance

## 2 Electrical Characteristics

Electrical characteristics at  $T_A = 25^\circ\text{C}$  (measured in test circuit specified in [Figure 2](#))

$V_{CC} = 3\text{ V}$ , unless otherwise specified

**Table 3 Electrical Characteristics**

Parameter	Symbol	Values			Unit	Note / Test Condition
		Min.	Typ.	Max.		
Maximum available power gain	$G_{MA}$		23		dB	$f = 0.9\text{ GHz}$
			14		dB	$f = 1.8\text{ GHz}$
Insertion power gain	$ S_{21} ^2$		17		dB	$f = 0.9\text{ GHz}$
			11		dB	$f = 1.8\text{ GHz}$
Reverse isolation	$ S_{12} $		60		dB	$f = 0.9\text{ GHz}$
			40		dB	$f = 1.8\text{ GHz}$
Noise figure ( $Z_S = 50\ \Omega$ )	$F_{50\Omega}$		1.2		dB	$f = 0.9\text{ GHz}$
			1.6		dB	$f = 1.8\text{ GHz}$
Output power at 1 dB gain compression ( $Z_S = Z_L = 50\ \Omega$ )	$P_{-1dB}$		-3		dBm	$f = 0.9\text{ GHz}$
			-3		dBm	$f = 1.8\text{ GHz}$
Output third order intercept point ( $Z_S = Z_L = 50\ \Omega$ )	$OIP_3$		14		dBm	$f = 0.9\text{ GHz}$
			14		dBm	$f = 1.8\text{ GHz}$
Device current	$I_D$		5.5		mA	

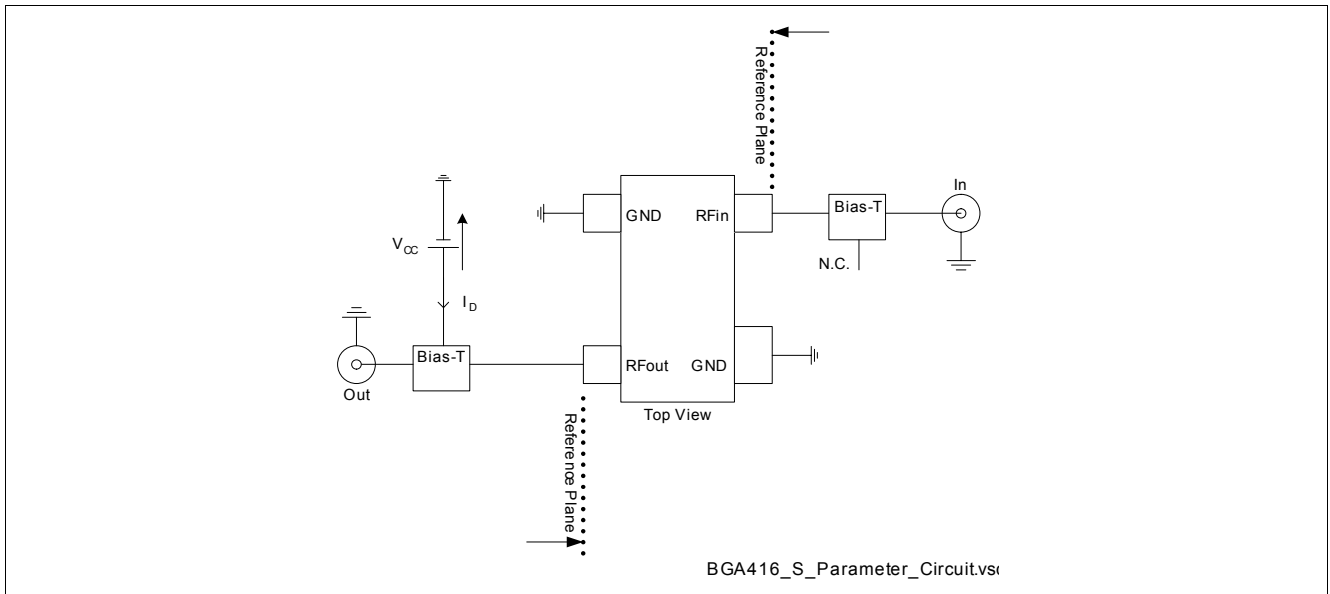

**Figure 2 Test Circuit for Electrical Characteristics**

### 3 Measured Parameters

**Power Gain**  $|S_{21}|^2, G_{ma} = f(f)$   
 $V_{CC} = 3V, I_D = 5.5mA$

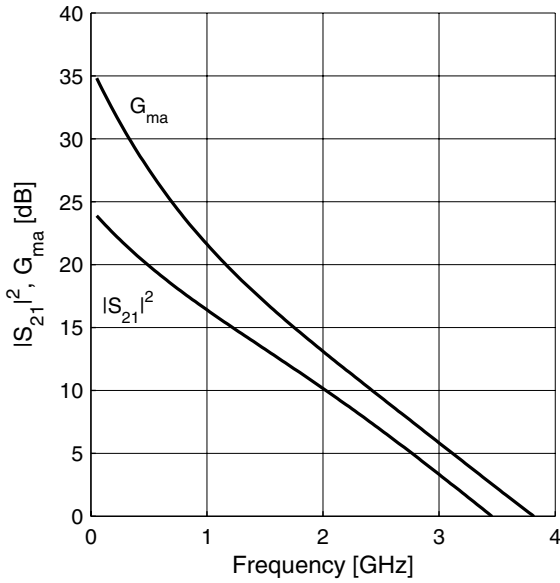

**Matching**  $|S_{11}|, |S_{22}| = f(f)$   
 $V_{CC} = 3V, I_D = 5.5mA$

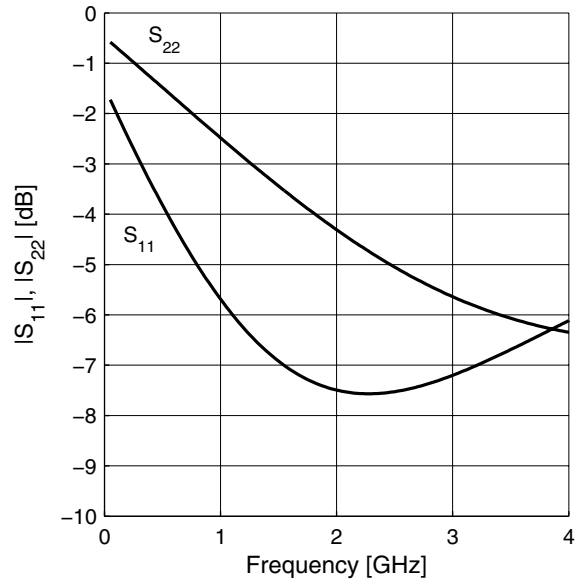

**Reverse Isolation**  $|S_{12}| = f(f)$   
 $V_{CC} = 3V, I_D = 5.5mA$

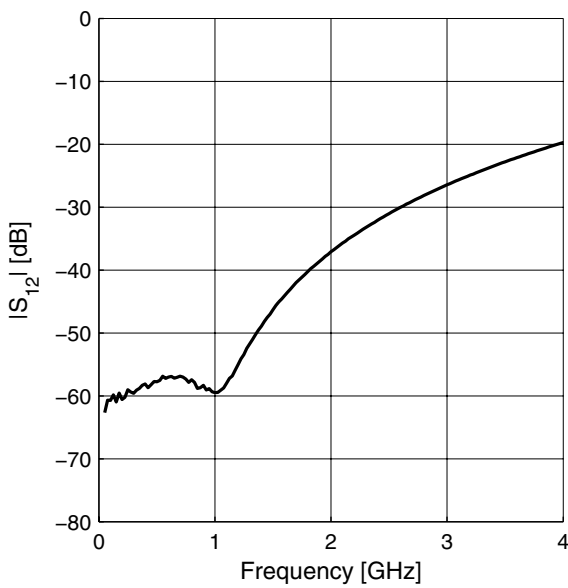

**Noise figure**  $F = f(f)$   
 $V_{CC} = 3V, I_D = 5.5mA$

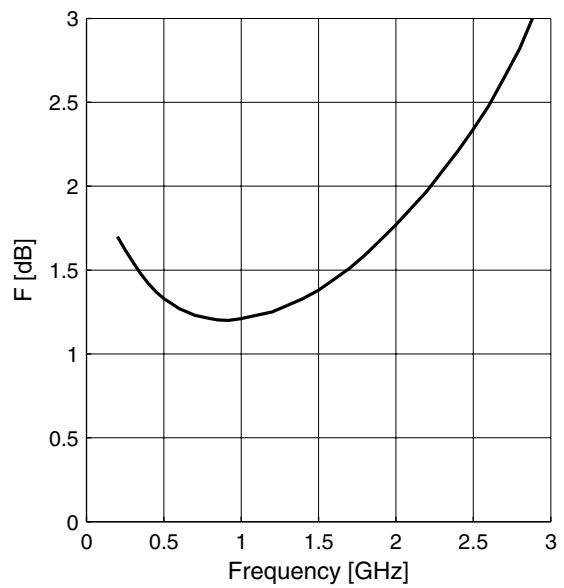

Device Current  $I_D = f(V_{CC})$

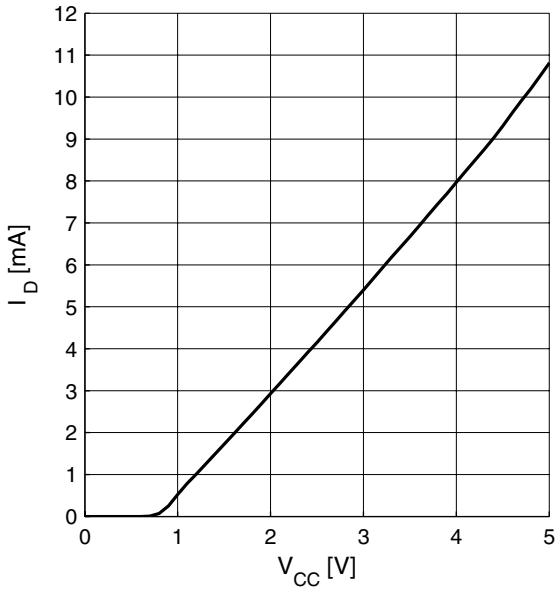

#### 4 Package Information

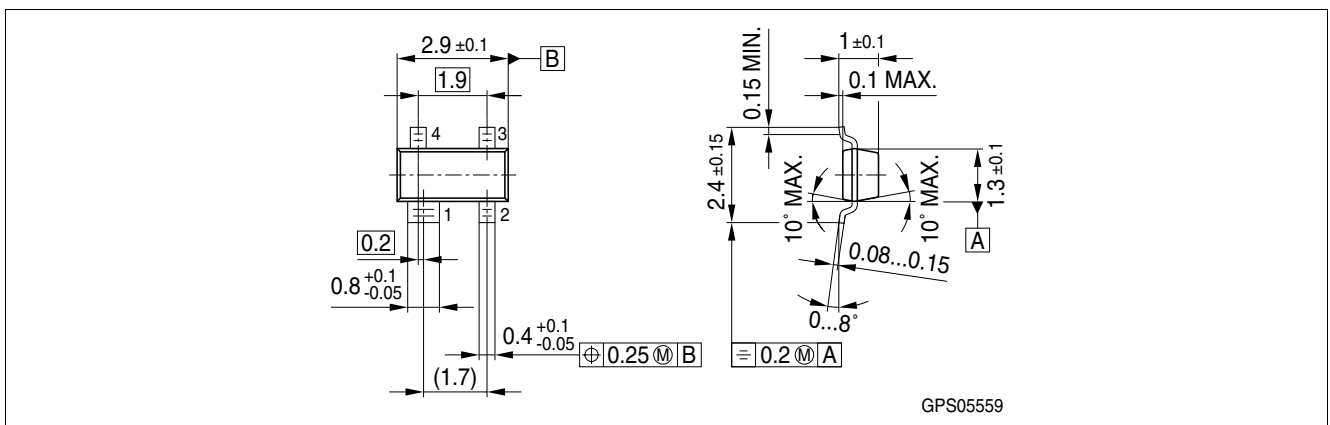

Figure 3 Package Outline SOT143

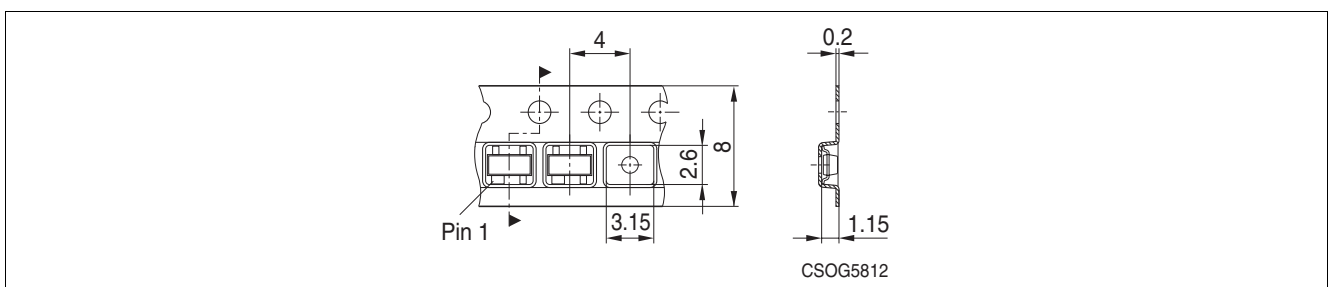



Figure 4 Tape for SOT143

## Looking for pricing, stock, or lifecycle information?

Click below to explore more details on WIN SOURCE:

-  [View BGA416E6327HTSA1 on WIN SOURCE](#)
-  [Infineon Technologies Information](#)

## Optimize Your Supply Chain with WIN SOURCE Solutions

-  Global Sourcing Solution
-  Obsolete Management
-  Cost Control Management
-  Shortage Management
-  Alternative Solution
-  Excess Inventory Management