



**THE DATASHEET OF  
BM64070MUV-E2**



DC Brushless Motor Driver Series

# Built-in Speed Control, Sensor-less Three-phase Brushless Motor Pre-driver

## BM64070MUV

### General Description

BM64070MUV is the pre-driver IC of sine wave drive for three-phase brushless motor driver that supports 48 V power supply controlling the motor driver constructed in external FETs. The sensor-less drive that the hall devices for the position sensing are unnecessary is adopted. It has a speed feedback control function, and controls output PWM Duty by adjusting the rotational frequency characteristics for the input PWM signal and the rotational frequency affected from motor.

### Features

- Speed Control on PWM Duty Input
- External Output FET Nch+Nch
- Built-in Boost Voltage Circuit
- Sensor-less Sine Wave Drive
- Automatic Lead Angle Control
- Dead Time Setting
- Current Limit Function
- Power Save Function
- Direction of Rotation Setting
- Short Brake Control
- Speed Feedback Control
- Able to Set Motor Rotation Speed Table and Various Parameters with the built-in OTP
- Built-in Several Protection (Motor Lock Protection [MLP], High Speed Rotation Protection, Over Voltage Lock Out [OVLO], Under Voltage Lock Out [UVLO], Thermal Shutdown [TSD], Over Current Protection [OCP])

### Key Specifications

- Operating Supply Voltage Range: 28 V to 77 V
- Circuit Current(I<sub>CC</sub>): 6.4 mA (Typ)
- Operating Temperature Range: -40 °C to +105 °C

### Package

VQFN040V6060

W (Typ) x D (Typ) x H (Max)

6.0 mm x 6.0 mm x 1.0 mm

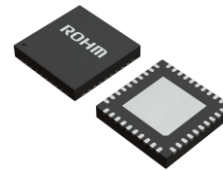

### Application

- Fan Motor
- Other General Consumer Equipment

### Typical Application Circuit

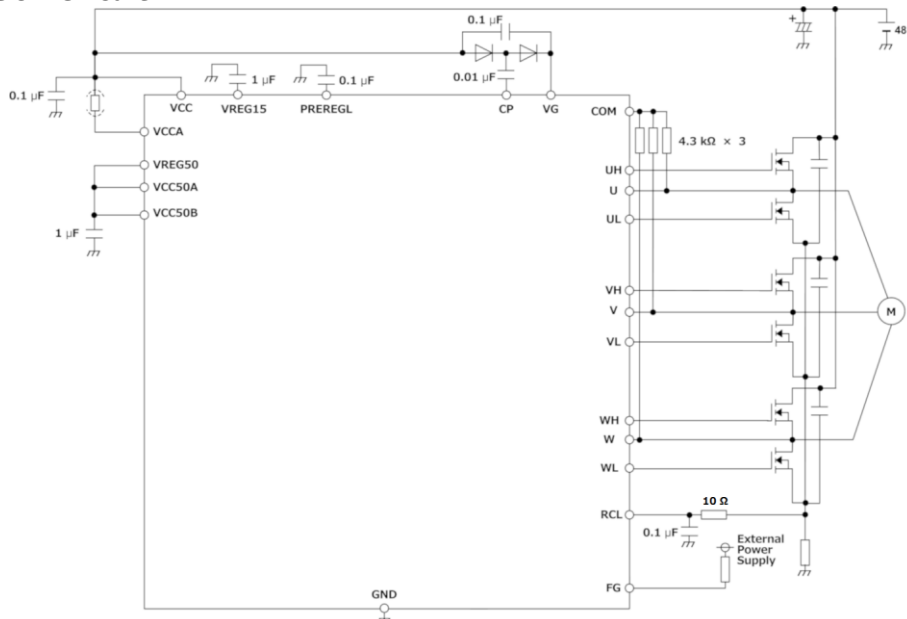

○Product structure : Silicon integrated circuit ○This product has no designed protection against radioactive rays

## Contents

General Description .....	1
Features.....	1
Key Specifications.....	1
Package .....	1
Application .....	1
Typical Application Circuit.....	1
Pin Configurations .....	3
Pin Descriptions .....	3
Block Diagram .....	4
Absolute Maximum Ratings.....	5
Thermal Resistance .....	5
Recommended Operating Conditions .....	6
Electrical Characteristics .....	6
Application Example.....	8
Board Design Note .....	8
Description of Pin Functions.....	9
Description of Operations .....	11
Thermal Resistance Model .....	20
I/O Equivalence Circuits .....	21
Operational Notes.....	23
Ordering Information .....	25
Marking Diagram.....	25
Physical Dimension and Packing Information .....	26
Packing Form .....	26
Quantity.....	26
Direction of feed.....	26
Revision History .....	27

## Pin Configurations(TOP VIEW)

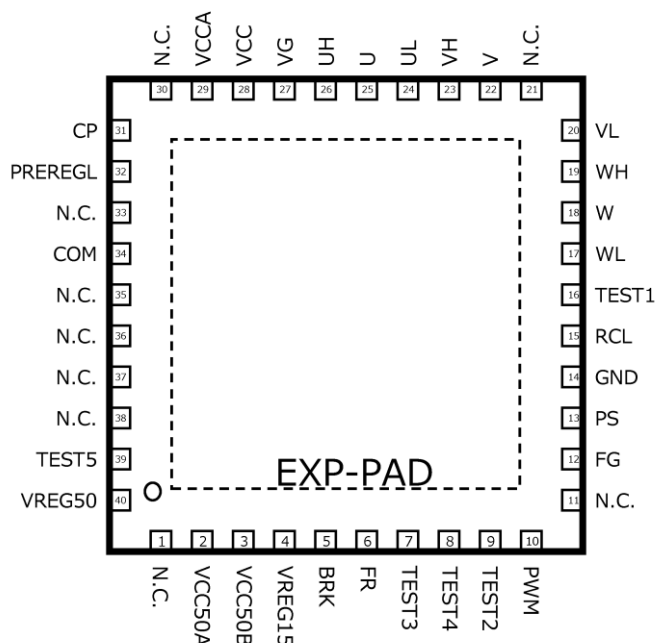

## Pin Descriptions

Pin No.	Pin Name	Function	Pin No.	Pin Name	Function
1	N.C.	N.C. (Open)	21	N.C.	N.C. (Open)
2	VCC50A	5V Regulator input for analog circuit	22	V	V phase external FET output feedback input
3	VCC50B	5V Regulator input for logic circuit	23	VH	V phase High side pre-driver output
4	VREG15	1.5V Regulator output for logic circuit	24	UL	U phase Low side pre-driver output
5	BRK	Brake control / SPI communication 1 data input-output	25	U	U phase external FET output feedback input
6	FR	Rotation direction setting / SPI communication 1 clock input	26	UH	U phase High side pre-driver output
7	TEST3	Test pin (Open or Connect to GND)	27	VG	Boost output
8	TEST4	Test pin (Open or Connect to GND)	28	VCC	Power supply
9	TEST2	Test pin (Open or Connect to GND)	29	VCCA	Power supply for 5V Regulator
10	PWM	PWM input (positive logic) / SPI communication 2 clock input	30	N.C.	N.C. (Open)
11	N.C.	N.C. (Open)	31	CP	Capacitor connection for boost
12	FG	Rotating speed pulse signal output / SPI communication 2 data input-output	32	PREREGL	Regulator output for Low side Pre-Driver
13	PS	Power Save input	33	N.C.	N.C. (Open)
14	GND	Ground	34	COM	Motor Coil Midpoint input
15	RCL	Output current detection voltage input	35	N.C.	N.C. (Open)
16	TEST1	Test pin (Open)	36	N.C.	N.C. (Open)
17	WL	W phase Low side pre-driver output	37	N.C.	N.C. (Open)
18	W	W phase external FET output feedback input	38	N.C.	N.C. (Open)
19	WH	W phase High side pre-driver output	39	TEST5	Test pin (Open)
20	VL	V phase Low side pre-driver output	40	VREG50	5V Regulator output
Back Side	EXP-PAD	Connect the EXP-PAD to the GND			

Block Diagram

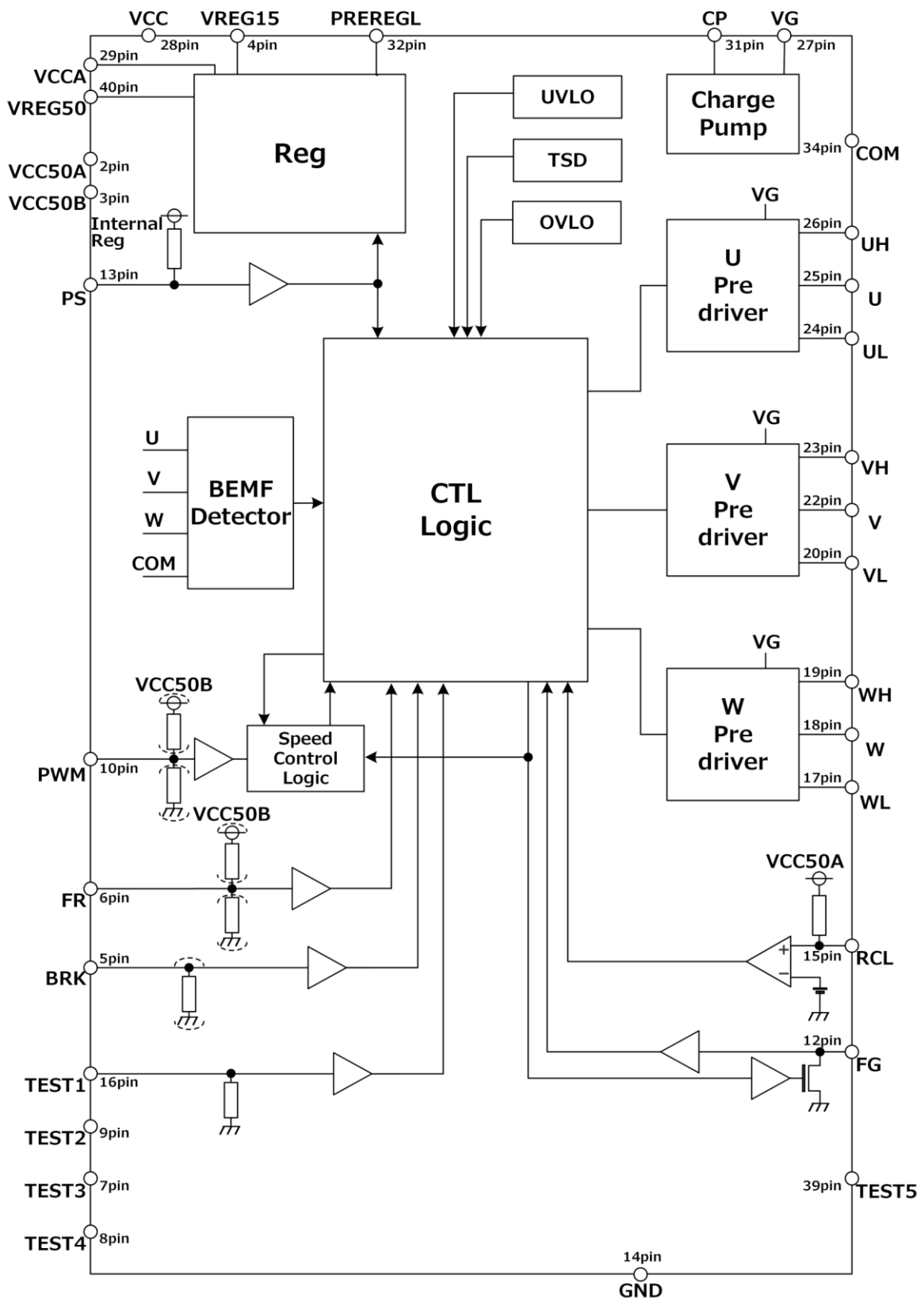

**Absolute Maximum Ratings(Ta = 25 °C)**

Parameters	Symbol	Rating	Unit
Power Supply Voltage (VCC)	V <sub>CC</sub>	100	V
Power Supply for 5V Regulator (VCCA)	V <sub>CCA</sub>	100	V
VG Voltage	V <sub>G</sub>	100	V
Pre-driver High Side Output Voltage (UH, VH, WH)	V <sub>OH</sub>	100	V
Pre-driver Low Side Output Voltage (UL, VL, WL)	V <sub>OL</sub>	20	V
Pre-driver Output-current* <sup>1</sup> (consecutive) (UH,VH,WH,UL,VL,WL)	I <sub>OMAX1</sub>	±2.0	mA
Pre-driver Output-current* <sup>2</sup> (UH,VH,WH,UL,VL,WL)	I <sub>OMAX2</sub>	±20	mA
External FET Output Feedback Voltage (U,V,W)	V <sub>FBI</sub>	100	V
Coil Midpoint Input Voltage (COM)	V <sub>COM</sub>	100	V
CP Pin Voltage	V <sub>CP</sub>	30	V
5V Input Voltage (VCC50A, VCC50B)	V <sub>VCC50</sub>	7	V
FG Pin Voltage	V <sub>FG</sub>	7	V
FG Pin Current	I <sub>FG</sub>	10	mA
VREG50 Pin Current* <sup>3</sup>	I <sub>VREG</sub>	-15	mA
RCL Pin Voltage	V <sub>RCL</sub>	4.5	V
Control Input Output Pin Voltage* <sup>4</sup>	V <sub>IO</sub>	7	V
Maximum Junction Temperature	T <sub>jmax</sub>	150	°C
Storage Temperature Range	T <sub>stg</sub>	-55 to +150	°C

**Caution 1:** Operating the IC over the absolute maximum ratings may damage the IC. The damage can either be a short circuit between pins or an open circuit between pins and the internal circuitry. Therefore, it is important to consider circuit protection measures, such as adding a fuse, in case the IC is operated over the absolute maximum ratings.

**Caution 2:** Should by any chance the maximum junction temperature rating be exceeded the rise in temperature of the chip may result in deterioration of the properties of the chip. In case of exceeding this absolute maximum rating, design a PCB with thermal resistance taken into consideration by increasing board size and copper area so as not to exceed the maximum junction temperature rating.

**Caution 3:** Unless otherwise specified, the absolute maximum ratings are at the time of shipment from ROHM (that is, the condition not written in OTP).

\*1 When internal resistor 1 kΩ (Typ) is used.

\*2 Pulse Width ≤ 1 μs, Pulse Duty ≤ 10 %. When internal resistor 1 kΩ (Typ) is used.

\*3 When VCCA connects to VCC.

\*4 The BRK, FR, PS, PWM, TEST1, TEST2, TEST3, TEST4, TEST5 pins

**Thermal Resistance\*<sup>1</sup>**

Parameter	Symbol	Thermal Resistance (Typ)		Unit
		1s* <sup>2</sup>	2s2p* <sup>3</sup>	
VQFN040V6060				
Junction to Ambient	θ <sub>JA</sub>	101.4	23.7	°C/W
Junction to Top Characterization Parameter * <sup>4</sup>	ψ <sub>JT</sub>	5.0	3.0	°C/W

Layer Number of Measurement Board	Material	Board Size
Single	FR-4	114.3 mm x 76.2 mm x 1.57 mmt

Top	
Copper Pattern	Thickness
Footprints and Traces	70 μm

Layer Number of Measurement Board	Material	Board Size	Thermal Via * <sup>5</sup>
4 Layers	FR-4	114.3 mm x 76.2 mm x 1.6 mmt	Pitch: 1.20 mm, Diameter: Φ0.30 mm

Top		2 Internal Layers		Bottom	
Copper Pattern	Thickness	Copper Pattern	Thickness	Copper Pattern	Thickness
Footprints and Traces	70 μm	74.2 mm x 74.2 mm	35 μm	74.2 mm x 74.2 mm	70 μm

\*1 Based on JESD51-2A (Still-Air).

\*2 Using a PCB board based on JESD51-3.

\*3 Using a PCB board based on JESD51-5, 7.

\*4 The thermal characterization parameter to report the difference between junction temperature and the temperature at the top center of the outside surface of the component package.

\*5 This thermal via connects with the copper pattern of all layers.

## Recommended Operating Conditions

Parameters	Symbol	Min	Typ	Max	Unit
Operation Temperature	Topr	-40	+25	+105	°C
Operating Supply Voltage (VCC)	V <sub>CC</sub>	28	48	77	V
Control Input Pin Voltage <sup>*1</sup>	V <sub>IN1</sub>	0	-	V <sub>VREG50</sub>	V

\*1 The BRK, FR, PS, PWM, TEST1, TEST2, TEST3, TEST4 pins

Electrical Characteristics (Unless otherwise specified V<sub>CC</sub> = V<sub>CCA</sub> = 48 V, Ta = 25 °C)

Parameters	Symbol	Min	Typ	Max	Unit	Conditions
<b>&lt;Whole&gt;</b>						
Circuit Current <sup>*1</sup>	I <sub>CC</sub>	-	6.4	9.6	mA	PS = 0 V, PWM = 0 V
Stand-by Current <sup>*1</sup>	I <sub>STBY</sub>	-	1.2	1.8	mA	PS = 5 V
VREG50 Voltage	V <sub>VREG50</sub>	4.5	5.0	5.5	V	
VREG15 Voltage	V <sub>VREG15</sub>	1.35	1.50	1.65	V	
PREREGL Voltage	V <sub>PREG</sub>	6.5	9.5	12.5	V	
<b>&lt;Boost Circuit&gt;</b>						
VG Voltage	V <sub>G</sub>	V <sub>CC</sub> +6.5	V <sub>CC</sub> +9.5	V <sub>CC</sub> +12.5	V	
<b>&lt;Pre-driver Output&gt;</b>						
High Side Output High Voltage	V <sub>OHH</sub>	V <sub>G</sub> -0.3	-	V <sub>G</sub>	V	
High Side Output Low Voltage	V <sub>OHL</sub>	0	-	0.3	V	
Low Side Output High Voltage	V <sub>OLH</sub>	V <sub>PREG</sub> -0.3	-	V <sub>PREG</sub>	V	
Low Side Output Low Voltage	V <sub>OLL</sub>	0	-	0.3	V	
Output PWM Frequency	f <sub>PWM</sub>	88	90	92	kHz	OTP : 90 kHz setting
<b>&lt;PS&gt;</b>						
Input Current	I <sub>PS</sub>	-82.5	-55.0	-27.5	μA	PS = 0 V
Input High Voltage	V <sub>STBY</sub>	3.8	-	5.0	V	Power Save
Input Low Voltage	V <sub>ENA</sub>	0	-	0.5	V	Drive
<b>&lt;FR&gt;</b>						
Input Current	I <sub>FR</sub>	-1.2	0	+1.2	μA	FR = V <sub>VREG50</sub>
Input High Voltage	V <sub>FRH</sub>	2.8	-	V <sub>VREG50</sub>	V	U→V→W
Input Low Voltage	V <sub>FRL</sub>	0	-	0.8	V	U→W→V
<b>&lt;BRK&gt;</b>						
Input Current	I <sub>BRK</sub>	-1.2	0	+1.2	μA	BRK = V <sub>VREG50</sub>
Input High Threshold Voltage	V <sub>BRKH</sub>	1.53	1.70	1.87	V	Short Brake
Input Low Threshold Voltage	V <sub>BRKL</sub>	1.35	1.50	1.65	V	Drive

Unless otherwise specified, the electrical characteristic values are at the time of shipment from ROHM (that is, the condition not written in OTP).

For parameters involving current, positive notation means inflow of current to the IC while negative notation means outflow of current from the IC.

\*1 Total value of VCC and VCCA circuit current.

**Electrical Characteristics – continued (Unless otherwise specified  $V_{CC} = V_{CCA} = 48 V$ ,  $T_a = 25 \text{ }^\circ\text{C}$ )**

Parameters	Symbol	Min	Typ	Max	Unit	Conditions
<b>&lt;Control Input: TEST1&gt;</b>						
Input Current	$I_{TEST1}$	25	50	75	$\mu\text{A}$	TEST1 = $V_{VREG50}$
Input High Voltage	$V_{TEST1H}$	$V_{VREG50}-1.0$	-	$V_{VREG50}$	V	SPI communication 1 mode
Input Low Voltage	$V_{TEST1L}$	0	-	0.8	V	Drive mode
<b>&lt;Control Input: TEST2, TEST3, TEST4 &gt;</b>						
Input Current	$I_{TEST}$	-1.2	-	+1.2	$\mu\text{A}$	TEST2 = $V_{VREG50}$ TEST3 = $V_{VREG50}$ TEST4 = $V_{VREG50}$
<b>&lt;Control Output: TEST5&gt;</b>						
Output Leak Current	$I_{TSLEAK}$	-	-	1	$\mu\text{A}$	TEST5 = 7 V
<b>&lt; Speed Control Input: PWM&gt;</b>						
Input Current	$I_{PWM}$	-1.2	0	+1.2	$\mu\text{A}$	PWM = $V_{VREG50}$
Input High Voltage	$V_{PWMH}$	2.8	-	$V_{VREG50}$	V	
Input Low Voltage	$V_{PWML}$	0	-	0.8	V	
Input Frequency	$f_{PWM}$	1	-	50	kHz	
<b>&lt;FG Output&gt;</b>						
Output Low Voltage	$V_{FGL}$	0	0.1	0.3	V	$I_{FGO} = +3 \text{ mA}$
Output Leak Current	$I_{FGLEAK}$	-	-	1	$\mu\text{A}$	FG = 7 V
<b>&lt;FG Input (SPI Communication Data Input) &gt;</b>						
Input High Voltage	$V_{FGINH}$	2.8	-	$V_{VREG50}$	V	
Input Low Voltage	$V_{FGINL}$	0	-	0.8	V	
<b>&lt; Current limit: RCL&gt;</b>						
Input Current	$I_{RCL}$	-35	-20	-10	$\mu\text{A}$	RCL = 0 V
Current limit Detect Voltage	$V_{CL}$	0.18	0.20	0.22	V	OTP: 0.2 V setting
<b>&lt;UVLO&gt;</b>						
VCC UVLO Release Voltage	$V_{UVH}$	18	20	22	V	
VCC UVLO Lockout Voltage	$V_{UVL}$	16	18	20	V	
VG UVLO Voltage	$V_{UVVG}$	$V_{CC}+2.0$	$V_{CC}+3.0$	$V_{CC}+4.0$	V	
<b>&lt;OVLO&gt;</b>						
OVLO Release Voltage	$V_{OVL}$	74.5	79.0	83.5	V	
OVLO Lockout Voltage	$V_{OVH}$	77.5	82.0	86.5	V	
<b>&lt; Motor Lock Protection, Several Protections &gt;</b>						
Motor Lock Protection Detect Time	$t_{LK\_DET}$	0.45	0.50	0.55	s	
Protect Time	$t_{LK\_PRT}$	4.5	5.0	5.5	s	Several Protections <sup>*1</sup>

Unless otherwise specified, the electrical characteristic values are at the time of shipment from ROHM (that is, the condition not written in OTP).

For parameters involving current, positive notation means inflow of current to the IC while negative notation means outflow of current from the IC.

\*1 Motor Lock Protection (MLP), High Speed Rotation Protection, Over Voltage Lock Out (OVLO), Thermal Shutdown (TSD), Over Current Protection (OCP).

Application Example

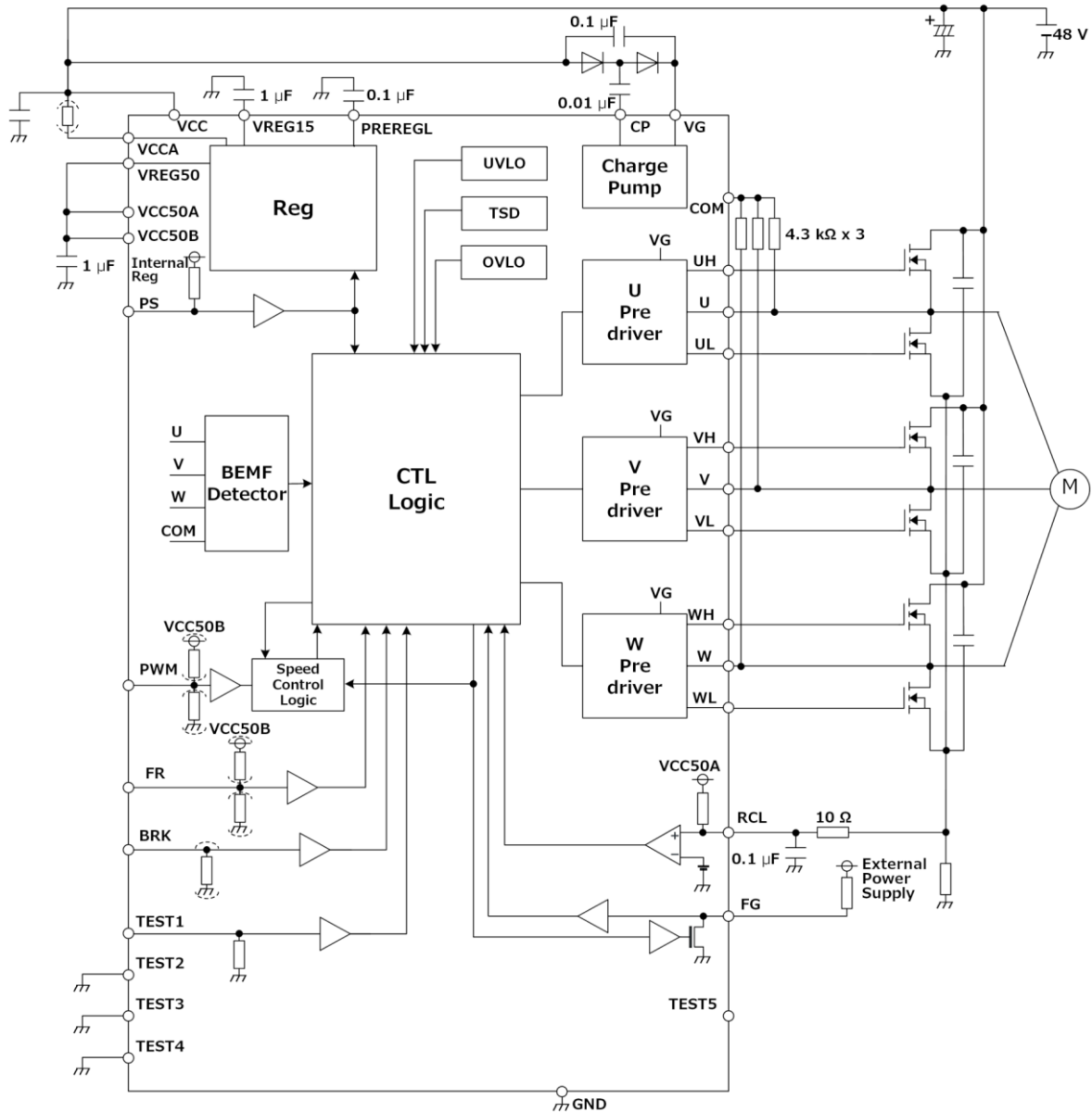

Board Design Note

1. The IC power supply, the IC ground, the motor outputs and the motor ground lines are made as wide as possible.
2. The IC ground is arranged to the ground connector of PCB as close as possible.
3. The bypass capacitors connected to the VCC pin and external FETs are placed as close as possible to the VCC pin and external FETs.

## Description of Pin Functions

### 1 Power Supply Pin (VCC)

- In order to decrease the AC impedance in wide frequency bandwidth, place a ceramic capacitor (0.01  $\mu$ F to 0.1  $\mu$ F) in parallel with the electrolytic capacitor.
- The motor's Back EMF and PWM switching noise may affect the VCC pin voltage. To regulate or stabilize the VCC voltage supply, place the bypass capacitor to the IC pin as close as possible. Increase the value of the bypass capacitor if the IC needs to drive higher current or if it is experiencing higher Back EMF. The VCC pin voltage must not exceed the absolute maximum ratings. It is effective to add a zener diode not exceeding the absolute maximum ratings. Take note that reversing the voltages of the VCC pin and the GND pin may destroy the IC.

### 2 Power Supply Pin (VCCA)

Connect to the VCC pin normally. When heat generation rise cannot be reduced sufficiently due to PCB design etc., connect a resistor (3.9 k $\Omega$  or less) between this pin and the VCC pin.

### 3 Ground Pin (GND)

The GND must have impedance as low as possible and must always be maintained as the lowest voltage potential. This is to reduce the noise caused by the switching current, and to make the internal standard voltages stable. Avoid having common impedance with other devices' GND line.

### 4 Boost Pins (CP, VG)

Built-in charge pump circuit (for High side external FET drive) generates boost voltage  $V_G = V_{CC} + 9.5$  V (Typ) by connecting capacitors and diodes to the CP pin, the VCC pin and the VG pin. It is recommended to use capacitor around 0.01 $\mu$ F for the CP pin side and to use capacitor around 0.1 $\mu$ F for the VG pin side. And it is recommended to use diode absolute maximum voltage 100 V or more, 0.8 A and reverse recovery time  $t_{rr} \leq 100$  ns.

### 5 High Side Pre-driver Output Pins (UH, VH, WH)

The external FET high side gate drive voltage is  $V_{CC} + 9.5$  V (Typ). Note that 500 k $\Omega$  (Typ) resistor is built between these pins (UH, VH, WH) and the FET output feedback pins (U, V, W) on each phase. In addition, the internal resistors are put between VG pin and each phase high side pre-driver output pin. The resistors are selected from 0.6 k $\Omega$  (Typ), 1 k $\Omega$  (Typ), 1.5 k $\Omega$  (Typ). When it can not be adjusted by these internal resistors, the setting without the internal resistors can be selected for using external resistors.

### 6 Low Side Pre-driver Output Pins (UL, VL, WL)

The external FET low side gate drive voltage is 9.5 V (Typ). Note that 200 k $\Omega$  (Typ) resistor is built between these pins (UL, VL, WL) and the GND on each phase. In addition, the internal resistors are put between the PREREGL pin and each phase low side pre-driver output pin. The resistors are selected from 0.6 k $\Omega$  (Typ), 1 k $\Omega$  (Typ), 1.5 k $\Omega$  (Typ). When it can not be adjusted by these internal resistors, the setting without the internal resistors can be selected for using external resistors.

### 7 External FET Output Feedback Input Pins (U, V, W)

Connect these pins to the source side of external High side FET. High side FET driver circuit generates High side pre-driver output voltage based on this pin. Do not leave this pin open, because the voltage higher than expected can be applied to the High side FET and cause destruction. Also, this pin can swing the GND potential or less under the influence of Back EMF by the motor, and cause malfunction or destruction if it reaches -1.4 V or less. Preventive measures, such as inserting schottky diodes to the GND, can avoid such unexpected IC destruction.

### 8 COM Input Pin (COM)

When the motor has middle point wiring, connect the wiring to the COM pin. When not so, the ideal middle point is made by connecting resistors between the U, V, and W pins and the COM pin. It is recommended that resistors are 1 k $\Omega$  to 4.3 k $\Omega$ . After checking a motor operation, decided the values. In addition, be careful about the power dissipation of the resistors.

### 9 Regulator Input Pins (VCC50A, VCC50B) / Output Pins (VREG15, VREG50)

The VREG50 pin is 5 V (Typ) for standard voltage output. And the VREG15 pin is 1.5 V (Typ) for internal power supply output for logic circuit. It is recommended to connect around 1  $\mu$ F capacitor to the VREG50 and VREG15 pins.

The VCC50A pin is 5 V input to internal analog circuit. And the VCC50B pin is 5 V input to internal logic circuit. Connect both pins to the VREG50 pin. And connect nothing to the VREG15 pin except a capacitor.

**Description of Pin Functions – continued**

**10 Power Save Pin (PS)**

The PS pin controls ON/OFF state on each phase output. The Power Save state has priority of turning off regulator output (VREG50, VREG15) over other control input signals. Furthermore, the PS pin is pulled up to internal power supply by 101 kΩ (Typ) resistor.

PS pin Setting	Function
Low	Drive
High / Open	Power Save

**11 Speed Control PWM Input Pin (PWM)**

The PWM signal Duty for the PWM pin can control motor speed. Refer to Description of Operations : Speed Feedback Control regarding the rotation speed setting of Speed feedback control. By writing OTP data, the PWM pin can be pulled up to VCC50B by 100 kΩ (Typ) resistor or be pulled down by 100 kΩ (Typ) resistor. In addition, refer to the Application Note about the SPI communication2 mode using the PWM pin.

**12 Output Current Detect Pin (RCL)**

The RCL pin is an input pin for the current limit comparator. Take into consideration the wiring pattern on the PCB to reduce noise when designing PCB layout. Note that the RCL pin is pulled up to VCC50A by 250 kΩ (Typ) resistor.

**13 FG Output Pin (FG)**

The FG pin outputs rotation speed signal. No output in Power Save mode or the several protections. The FG pin is open drain output, so this pin must be pulled up to external voltage by 10 kΩ to 100 kΩ resistor. Note that FG voltage and current should not exceed the maximum absolute ratings. In addition, refer to the Application Note about the SPI communication2 mode using the FG pin.

**14 Rotation Direction Setting Pin (FR)**

The FR pin controls rotational direction change. Phase driving sequence is U→V→W when FR=High, and U→W→V when FR=Low or Open. Changing the rotational direction during motor rotation is not recommended. If the rotational direction is changed, it enters short brake mode for 5 s (Typ). By writing OTP data, the FR pin can be pulled down by 100 kΩ (Typ) resistor, or be pulled up by 100 kΩ (Typ) resistor to VCC50B.

FR pin Setting	Function
Low	U→W→V
High	U→V→W

**15 Brake Control Pin (BRK)**

The BRK pin can stop a rotation. It enters short brake mode with BRK=High, wherein all high side external FETs are turned off and all low side external FETs are turned on. It cancels short brake mode when BRK=Low. When the BRK function is not used, connect the BRK pin to the GND pin. By writing OTP data, the BRK pin can be pulled down by 100 kΩ (Typ) resistor.

BRK pin Setting	Function
Low	Drive
High	Brake

**16 Voltage Output for Low Side Pre-driver Pin (PREREGL)**

The PREREGL pin is 9.5 V (Typ) for internal power supply output for low side pre-driver circuit. It is recommended to connect 0.1 μF or more to the PREREGL pin. And connect nothing to the PREREGL pin except a capacitor.

**17 Non Connection Pin (N.C.)**

No electrical connection with IC internal circuit.

**18 TEST1 Pin (TEST1)**

By connecting the TEST1 pin to VREG50, the BRK pin and the FR pin is changed to the pins for the SPI communication 2. Refer to the Application Note about the way to set the SPI communication 2. When SPI communication 2 is NOT used, open or connect the TEST1 pin to GND. The TEST1 pin is pulled down by 100 kΩ (Typ) resistor.

**19 TEST2, TEST3, TEST4, and TEST5 Pins (TEST2, TEST3, TEST4, TEST5)**

These are for TEST.

## Description of Operations

### 1 The Various Parameter Settings and OTP Writing

The various parameters can be set according to the characteristics of the motor, and those parameters can be written to OTP. The data written on the OTP are set to registers when the IC is powered on. If the data is not written on the OTP, registers are set default value shown in the register map. Refer to the Application Note about OTP setting. In this document, default value is described.

### 2 Sensor-less Sine Wave Drive

This is a motor driver IC for sensor-less sine wave drive that does not require the hall devices as a position detection sensor. And, it drives the output current of a three-phase brushless DC motor with a sine waveform.

#### 2.1 The Operation at the startup

At the time that the IC starts, it checks the rotation of a rotor in Normal Rotation Judgement section for 100 ms (Typ). When forward rotation is detected, the IC is in Back EMF Detection Driving section. When reverse rotation is detected, all external FETs are Low to stop a rotor. After 5 s (Typ), the IC is in Normal Judgement section again. When other situation, the IC judges that a rotor stops, and it is in Fixed Initial Position section. In this section, a rotor is fixed to the initial position for a certain period. After this section, the IC is in Forcibly Synchronized startup section. In this section, a rotor speed accelerates by shortening gradually a period of output switching for 8 electrical periods.<sup>\*1</sup> After this section, the IC is in Back EMF Detection Driving section. In the timing chart below, the start by the power supply injection (the VCC pin) is described as an example.<sup>\*2</sup>

\*1 An electrical period is a period of electrical output switching. It is Not a period of rotor rotation.

\*2 In the startup command to start from the motor stop state, there are the start by the torque input (the PWM pin), the start by the power save cancellation (the PS pin), the return from the short brake mode at the time of the rotational direction change (the FR pin), and the return from the motor stop state by each protection function. These operate similarly.

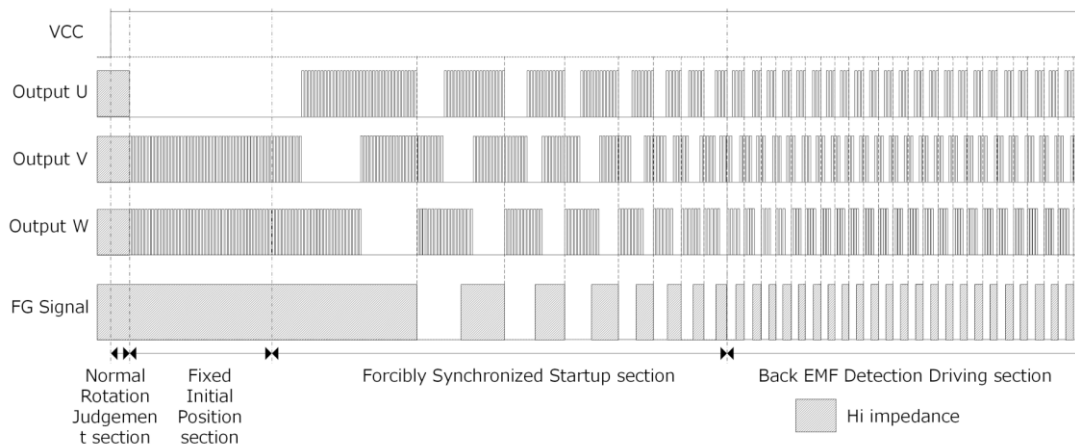

Timing Chart of Output Signal (U, V, W) and FG Signal

Section	Function
Normal Rotation Judgement section	Detect the rotation of the rotor
Fixed Initial Position section	Fix the rotor in the initial position
Forcibly Synchronized Startup section	The rotor speed accelerates by shortening gradually a period of output switching
Back EMF Detection Driving section	Normal Sin driving by Back EMF detection

#### 2.2 Period Setting of Output Switching at Forcibly Synchronized Startup Section

In Forcibly Synchronized startup section, a period of output switching and its acceleration are decided by the Based Period and the Acceleration Curve. A period of output switching and its acceleration depend on the various characteristic parameters of a motor. It is necessary to select the optimum value for stable motor startup.

**Description of Operations - continued**

**3 Timing Chart in Steady Drive**

The timing chart of each output phase (U, V, W) and FG signal are shown in below. FG signal is divided by the motor pole setting.

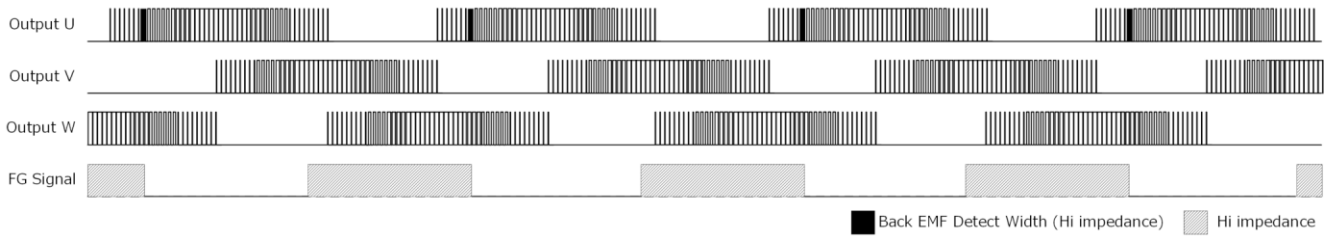

FR=High (U→V→W, lead angle 0°, poles=4 setting)

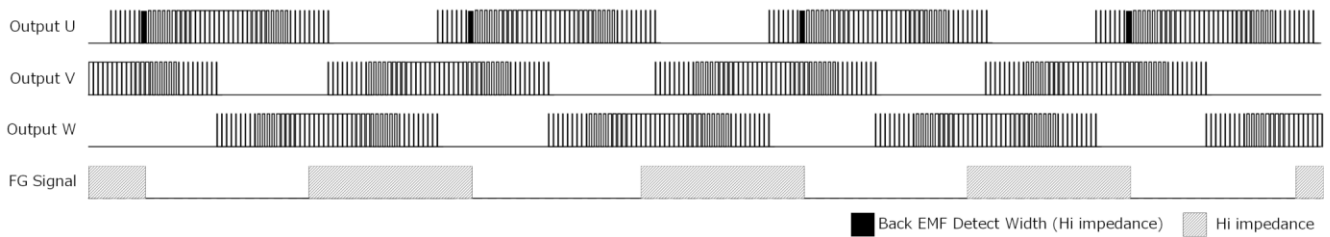

FR=Low (U→W→V, lead angle 0°, poles=4 setting)

**4 Back EMF Mask Function and PWM Mask Function**

Built-in Back EMF window mask and PWM window mask. These depend on the various characteristic parameters of the motor. It is necessary to select the optimum value for stable motor drive.

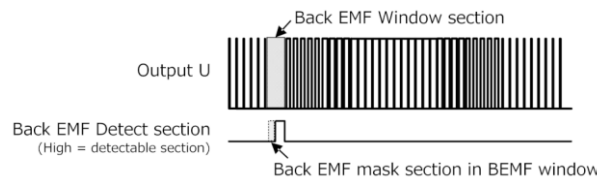

Back EMF Window Mask

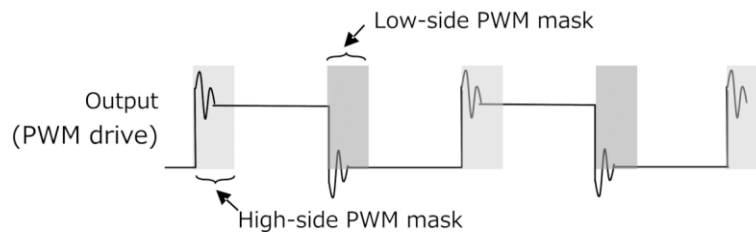

PWM Mask

**5 Motor Pole Setting Function**

The motor pole setting is possible to 2 poles, 4 poles, 6 poles, 8 poles, 10 poles, 12 poles, 14 poles and 16 poles. The motor pole setting affects the detection rotation speed of the High Speed Rotation Protection and the PI adjustment of the speed control by the rotation speed. Set according to the motor poles.

**6 Dead Time Setting Function**

It can set the time to turn off the external FET in-phase. It depends on the various characteristic parameters of the motor. It is necessary to select the optimum value for stable motor drive.

**Description of Operations – continued**

7 Current Limit Function

7.1 Current Limit Setting (the RCL pin)

When the IC detects the coil current of the current setting value or more at steady rotation, all high side external FETs are turned off and cut off the current. When the current is less than the current value setting in the timing of next PWM (ON) after that, it returns to normal drive. Setting current value  $I_O$  that operates the current limit is determined on the current limit setting voltage ( $V_{CL}$ ) in the IC and the resistance  $R_1$  to use for the coil current detection. Refer to the formula shown below in the case of  $V_{CL} = 0.2\text{ V}$ ,  $R_1 = 0.2\ \Omega$ .

$$\begin{aligned}
 I_O \text{ [A]} &= V_{CL} \text{ [V]} / R_1 \text{ [\Omega]} & P_C \text{ [W]} &= V_{CL} \text{ [V]} \times I_O \text{ [A]} \\
 &= 0.2 / 0.2 & &= 0.2 \times 1.0 \\
 &= 1.0 \text{ A} & &= 0.2 \text{ W}
 \end{aligned}$$

A large current flows through the resistor  $R_1$  to detect the coil current. Because the power consumption  $P_C$  is calculated with the formula shown above, pay attention to the power dissipation. As shown in below when designing PCB layout, separate the IC small signal GND line with the motor large current GND line which  $R_1$  is connected.

About the resistor  $R_2$  to use as a filter, it is recommended around  $10\ \Omega$  because the current limit level shifts by a partial pressure with  $250\ \text{k}\Omega$  (Typ) when it is too large.

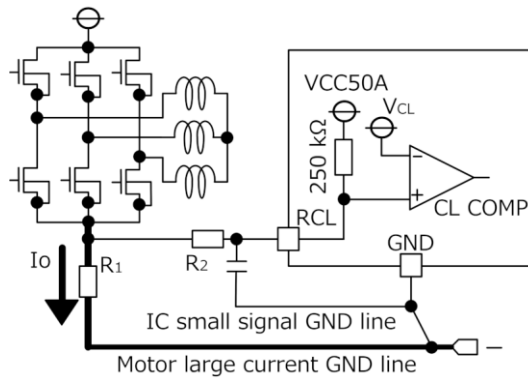
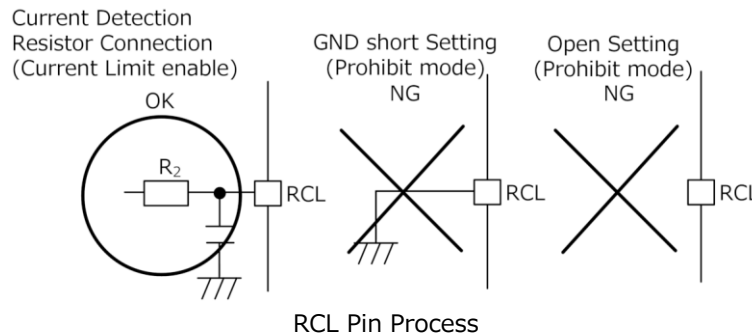

Small Signal and Large Current GND Line Separation

7 Current Limit Function – continued

7.2 startup from Motor Stop

The timing chart of the current limit (CL) at the startup from the motor stop is shown in below. The CL setting can set at each drive section. It depends on the various characteristic parameters of the motor. It is necessary to select the optimum value for stable motor start. The recommended CL setting voltage ( $V_{CL}$ ) in Back EMF detection drive section is 0.20 V (Typ). It has Soft Start function in this section. The CL setting voltage increases 5.16 mV (Typ) every a step time (101 ms [Typ]). In the timing chart below, the start by the power supply injection (VCC) is described as an example<sup>\*1</sup>.

\*1 In the Startup command to start from the motor stop state, there are the start by the torque input (the PWM pin), the start by the power save cancellation (the PS pin), the return from the short brake mode at the time of the rotational direction change (the FR pin), and the return from the motor stop state by each protection function. These operate similarly.

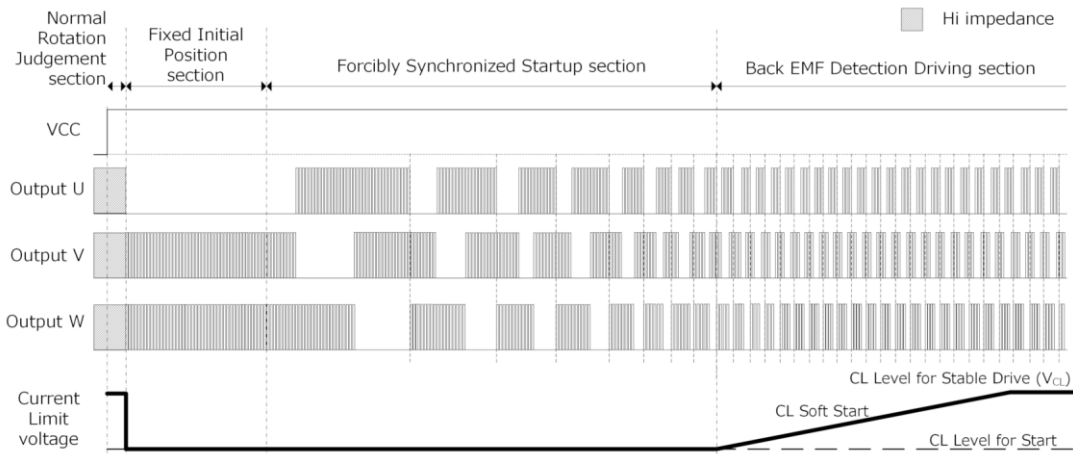

Timing Chart of Current Limit at the startup from Motor Stop

7.3 Startup from Forward Rotation Detection

At the time that the IC starts, the timing chart of the current limit (CL) at the Startup from the free run is shown in below when forward rotation is detected in Normal Rotation Judgement section and the IC is in Back EMF Detection Driving section. The CL setting can be set each drive section. The CL and a duty value at the Startup depend on the various characteristic parameters of the motor. It is necessary to select the optimum value for stable motor start. In the timing chart below, the start by the power supply injection (VCC) is described as an example<sup>\*1</sup>.

\*1 In the Startup command to start from the motor stop state, there are the start by the torque input (the PWM pin), the start by the power save cancellation (the PS pin), the return from the short brake mode at the time of the rotational direction change (the FR pin), and the return from the motor stop state by each protection function. These operate similarly.

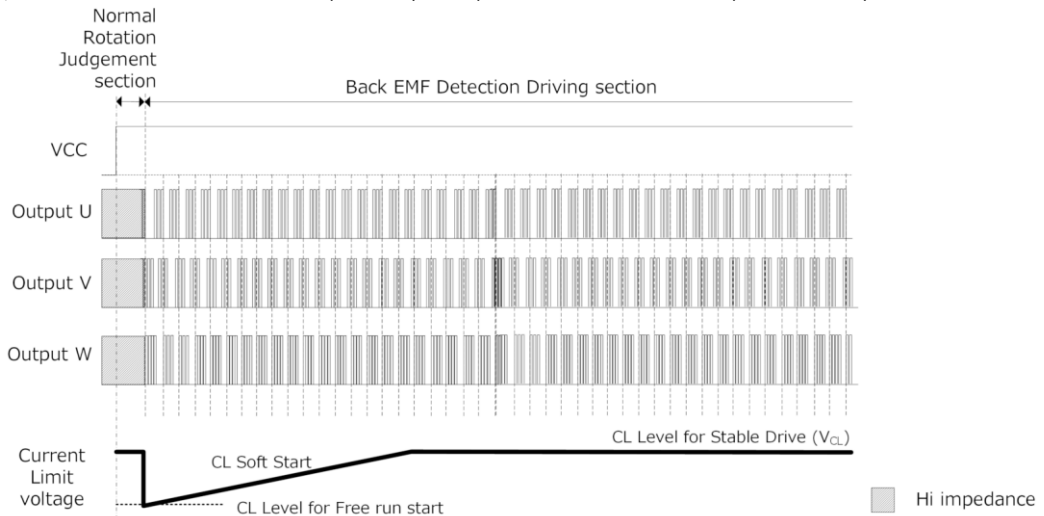

Timing Chart of Current Limit at the Startup from Free Run Detection

**Description of Operations – continued**

**8 Motor Lock Protection (MLP)**

When the motor is locked due to disturbance factors, the IC has a protection function that turns off all external FETs for a certain period [protection time  $t_{LK\_PRT}$ : 5.0 s (Typ)] so that the current will not continue to flow in the coil current. In addition, it has a function that automatically restarts after lock protection time. Back EMF is detected as the motor rotates. However, when the motor is locked, it is not detected. When it is not detected for a certain period [Motor lock protection detect time  $t_{LK\_DET}$ : 0.5 s (Typ)], the IC judges as the motor is locked. The timing chart of each output phase during lock protection is shown in below.

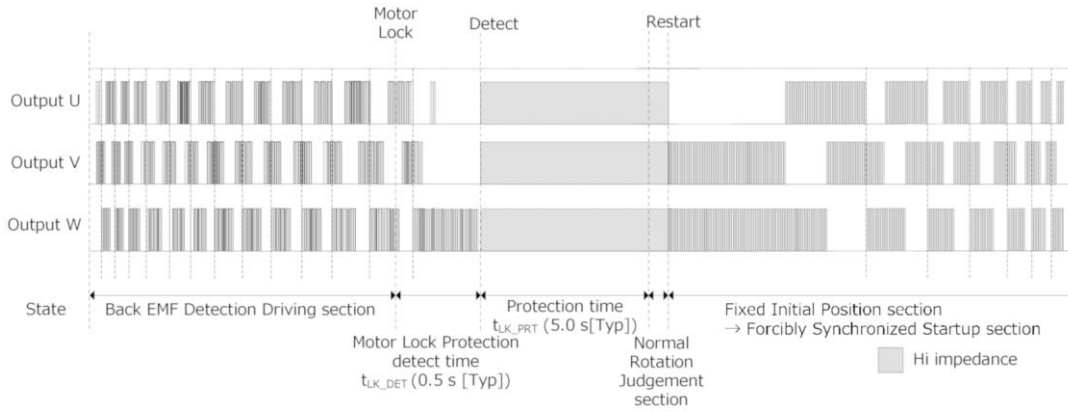

Timing Chart during Motor Lock Protection

**9 High Speed Rotation Protection**

When a rotating speed rises by uncontrollable motor and reaches 40,300 rpm (Typ) or more, the High Speed Rotation Protection works and all external FETs are turned off for a certain period [protect time  $t_{LK\_PRT}$ : 5.0 s (Typ)]. After the Protect time, the High Speed Rotation Protection is cancelled when a rotating speed reaches less than 40,300 rpm (Typ). The timing chart of each output phase during high speed rotation protection is shown in below.

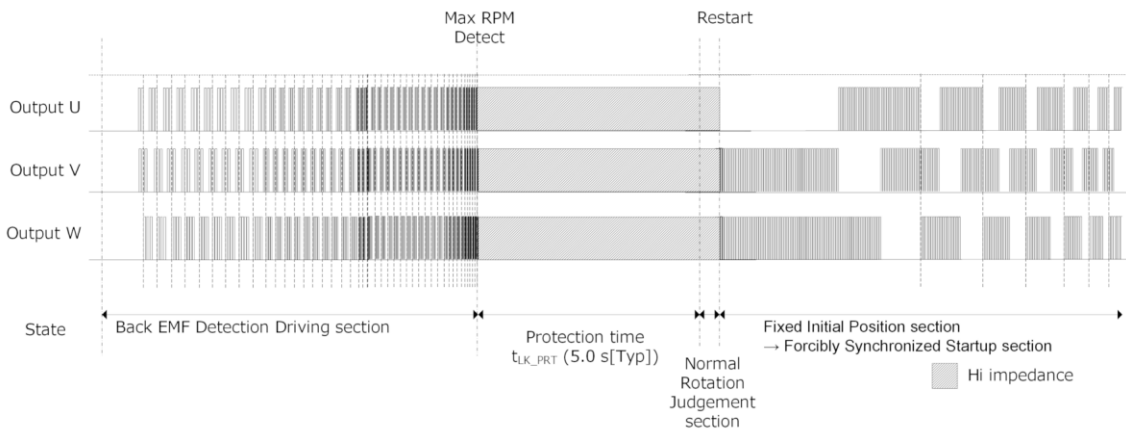

Timing Chart during High Speed Rotation Protection

**10 Over Voltage Lock Out (OVLO)**

When VCC reaches 82 V (Typ) or more, OVLO works and it enters short brake mode, wherein all high side external FETs are turned off and all low side external FETs are turned on for a certain period [protect time  $t_{LK\_PRT}$ : 5.0 s (Typ)]. In addition, the boost function for VG voltage is turned off. OVLO circuit has hysteresis of 3 V (Typ), and OVLO is cancelled when VCC reaches 79 V (Typ) or less after the protect time. This circuit has mask time of 4  $\mu$ s (Typ) to prevent malfunctions.

**Description of Operations – continued**

11 Under Voltage Lock Out (UVLO)

In extremely low supply voltage domain deviating from normal operation, it is a protection function that prevents the unexpected operations such as large current flow in drive FET by turning off all external FETs intentionally. UVLO works and all external FETs are turned off when VCC reaches 18 V (Typ) or less. And the regulator outputs (VREG50, VREG15, PREREGL) and the boost voltage circuit are turned off. UVLO circuit has hysteresis of 2 V (Typ), and UVLO is cancelled when VCC reaches 20 V (Typ) or more.

12 Thermal Shutdown (TSD)

When the chip temperature reaches 175 °C (Typ) or more, TSD works and all external FETs are turned off for a certain period [protect time  $t_{LK\_PRT}$ : 5.0 s (Typ)]. TSD circuit has hysteresis of 25 °C (Typ), and TSD is cancelled when the chip temperature drops after the protect time. Moreover, the purpose of the TSD circuit is to protect driver IC from thermal breakdown, therefore, thermal design should have sufficient margin, so do not take continuous use and action of the circuit as a precondition.

13 Over Current Protection (OCP)

Built-in Over Current Protection circuit is possible to protect from power supply short fault only. When the specified current or more is detected, OCP works and all external FETs are turned off for a certain period [protect time  $t_{LK\_PRT}$ : 5.0 s (Typ)]. When it is not detected after the protect time, OCP is canceled.

14 VG Under Voltage Lock Out (VG UVLO)

When VG reaches VCC+3.0 V (Typ) or less, VG UVLO works and all external FETs are turned off. VG UVLO circuit has no hysteresis.

15 Priority of Protection

This IC has a priority order in each protection operation as shown below. The protection with higher priority will be activated during the protection with lower priority.

Priority Order	Protection
1st	UVLO
2nd	OCP
3rd	TSD
4th	OVLO
5th	MLP, High Speed Rotation Protection, VG UVLO

16 Auto Lead Angle Control

It has the auto lead angle function which enables a high efficiency drive by matching the phase of the coil current to the phase of the Back EMF voltage generated to the coil automatically while driving the motor. The lead angle adjustment range is from 0° to 45°.

**Description of Operations – continued**

17 Speed Feedback Control

It has a speed feedback control to keep the motor rotation speed constant. It controls a drive duty so that the target motor rotation speed that set by the PWM pin and the frequency of internal FG signal are equal. The block diagram of speed feedback control is shown in below.

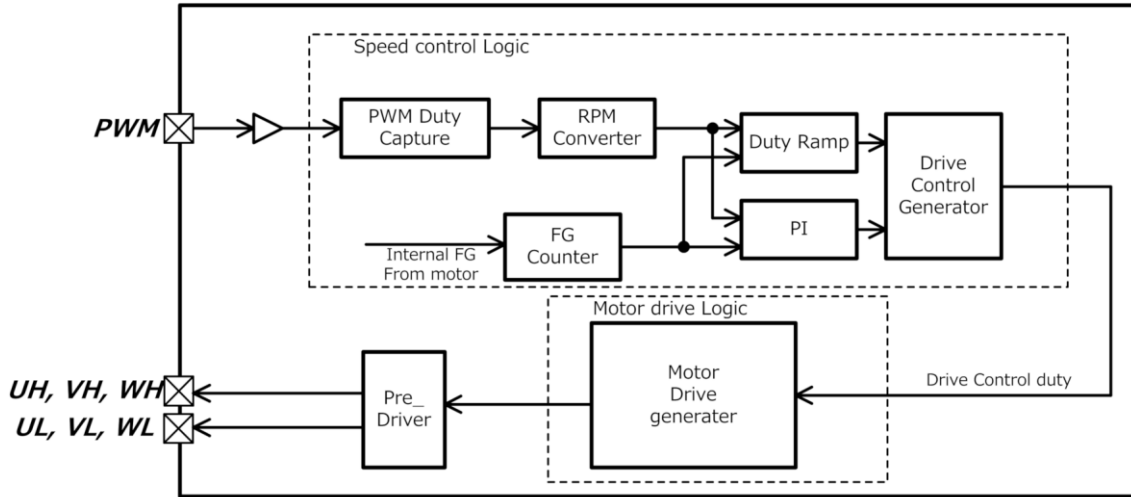

17.1 Relations of the Input PWM Duty and the Target RPM

The relations of the input PWM Duty and the Target RPM are shown in below. The relation of the maximum Target RPM when input PWM Duty=100 % and the motor poles is calculated below.

$$Target\ RPM\ (Max) = 1,024 \times (64 + 1) \times 0.25 \times \frac{4}{poles}$$

The example is shown below.

$$poles = 4 \quad (initial\ Value)$$

$$Target\ RPM\ (Max) = 1,024 \times (64 + 1) \times 0.25 \times \frac{4}{4} = 16640\ rpm$$

This IC also has Low PWM Off function. As shown in below, it judges the drive off at the point A or less and the motor can be stopped. Moreover, it judges the drive on at the point B or more and the motor can be rotated.

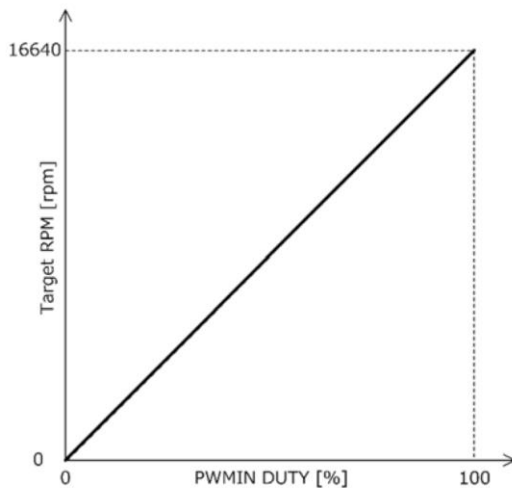

PWM Duty and Target RPM (poles=4 setting)

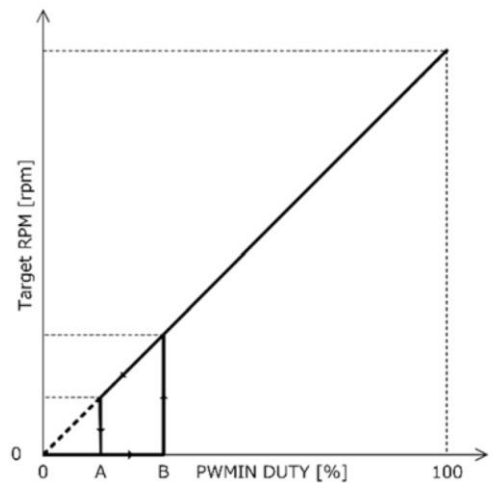

Low PWM OFF Function

17 Speed Feedback Control - contined

17.2 Motor RPM Measurement

For the motor RPM, a half period of the internal FG signal is measured. This measured value is compared with a half target period which is calculated from the Target RPM. And this difference is the speed error value. When the half period of the internal FG signal is longer (slower than the Target RPM), the speed error value becomes minus. On the other hand, when it is shorter (faster than Target RPM), the speed error value becomes plus.

17.3 Setting of Motor Speed Control

Built-in RAMP control drive and PI control drive. The setting method is shown in below.

Start and Acceleration / Deceleration Operation	Stable Operation
RAMP control drive	PI control drive

17.4 PI Control

It drives the speed feedback control using the PI control. The Drive Control Duty (Drive control) is calculated from the proportional gain ( $K_P = 1.0$ ) and the integral gain ( $K_I = 0.012$ ) regarding the speed error value (Error Value). The PI control block diagram is shown in below.

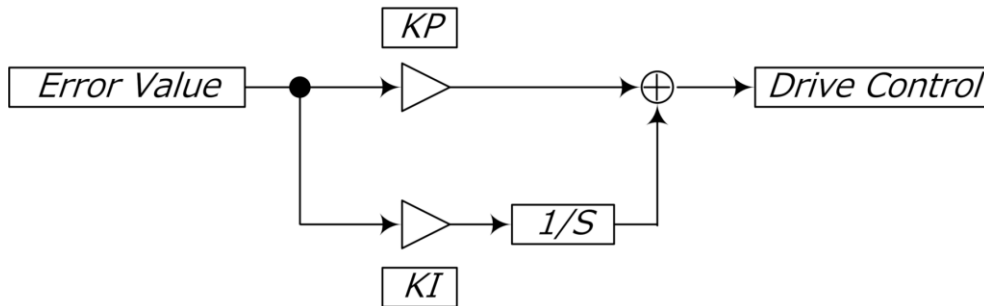

17 Speed Feedback Control - continued

17.5 RAMP Control

The Drive Control Duty increases gradually when the speed error value is minus (slower than the Target RPM), and decreases gradually when the speed error value is plus (faster than the Target RPM). So the real motor rotation speed approaches the target motor rotation speed. An increase/decrease step width of the Drive Control Duty is 0.49 % every 52 ms as shown in below.

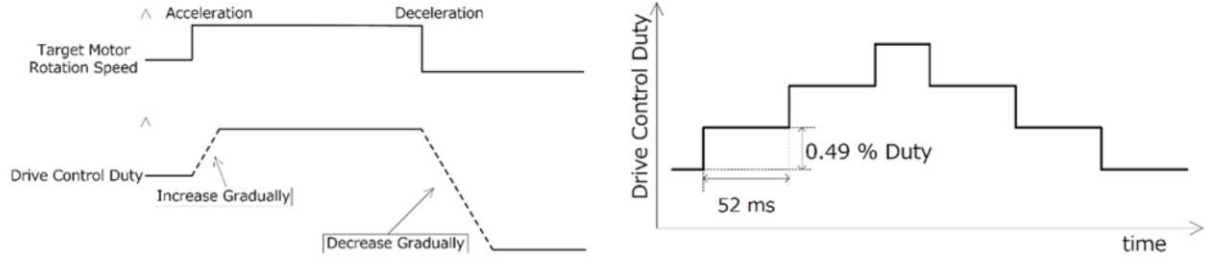

The RAMP Control Function Summary

RAMP STEP

About shifting from the RAMP control to the PI control, the state shifts to the PI control when the speed error value is settled with 1.57 % or less. In the large domain of the speed error value, the real motor rotation speed approaches the target motor rotation speed operating the RAMP control. So the speed error value becomes small, it starts the PI control. It facilitates parameter adjustment.

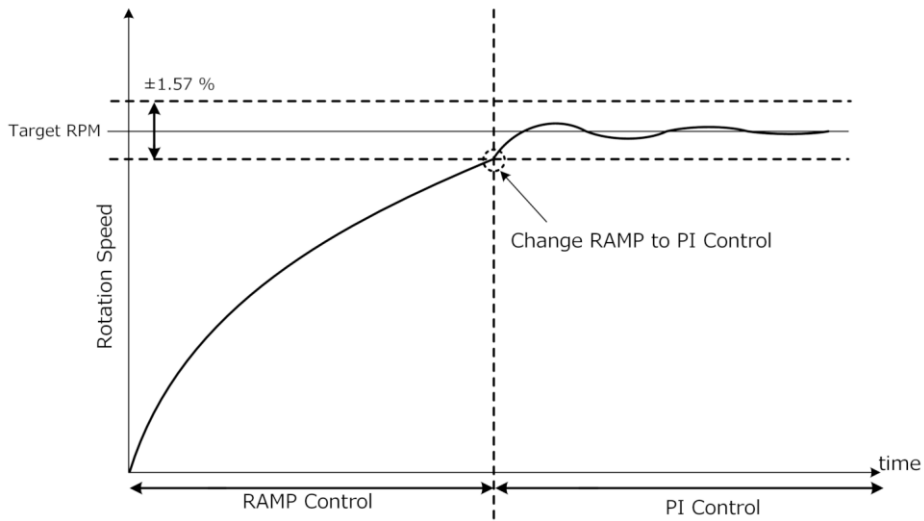

The State Switch from the RAMP Control to the PI Control

**Thermal Resistance Model**

Heat generated by consumed power of IC is radiated from the mold resin or lead frame of package. The parameter which indicates this heat dissipation capability (hardness of heat release) is called thermal resistance. Thermal resistance from the chip junction to the ambient is represented in  $\theta_{JA}$  ( $^{\circ}\text{C}/\text{W}$ ), and thermal characterization parameter from junction to the top center of the outside surface of the component package is represented in  $\psi_{JT}$  ( $^{\circ}\text{C}/\text{W}$ ). Thermal resistance is divided into the package part and the substrate part. Thermal resistance in the package part depends on the composition materials such as the mold resins and the lead frames. On the other hand, thermal resistance in the substrate part depends on the substrate heat dissipation capability of the material, the size, and the copper foil area etc. Therefore, thermal resistance can be decreased by the heat radiation measures like installing a heat sink etc. in the mounting substrate. The equations are shown below and the thermal resistance model is shown in below.

Equation

$$\theta_{JA} = \frac{Tj-Ta}{P} \text{ [}^{\circ}\text{C}/\text{W}\text{]}$$

$$\psi_{JT} = \frac{Tj-Tt}{P} \text{ [}^{\circ}\text{C}/\text{W}\text{]}$$

Where:

- $\theta_{JA}$  is the thermal resistance from junction to ambient ( $^{\circ}\text{C}/\text{W}$ )
- $\psi_{JT}$  is the thermal characterization parameter from junction to the top center of the outside surface of the component package ( $^{\circ}\text{C}/\text{W}$ )
- $Tj$  is the junction temperature ( $^{\circ}\text{C}$ )
- $Ta$  is the ambient temperature ( $^{\circ}\text{C}$ )
- $Tt$  is the package outside surface (top center) temperature ( $^{\circ}\text{C}$ )
- $P$  is the power consumption (W)

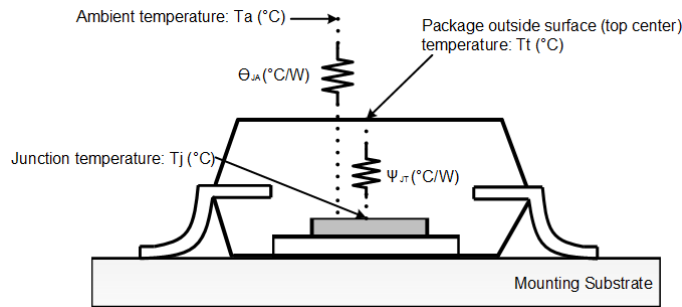

Thermal Resistance Model of Surface Mount

Even if it uses the same package,  $\theta_{JA}$  and  $\psi_{JT}$  are changed depending on the chip size, power consumption and the measurement environments of the ambient temperature, the mounting condition and the wind velocity, etc.

I/O Equivalence Circuits

<p>4</p> <p>VREG15</p>		<p>5</p> <p>BRK</p>	<p>BRK</p>
<p>6</p> <p>FR</p>	<p>FR</p>	<p>7</p> <p>TEST3</p>	<p>TEST3</p>
<p>8</p> <p>TEST4</p>	<p>TEST4</p>	<p>9, 10</p> <p>TEST2, PWM</p>	<p>TEST2, PWM</p>
<p>12</p> <p>FG</p>	<p>FG</p>	<p>13</p> <p>PS</p>	<p>PS</p>

I/O Equivalence Circuits - continued

<p>15</p> <p>RCL</p>		<p>16</p> <p>TEST1</p>	<p>TEST1</p>
<p>17, 20, 24</p> <p>WL, VL, UL</p>		<p>18, 19, 22, 23, 25, 26, 27</p> <p>W, WH, V, VH, U, UH, VG</p>	
<p>31</p> <p>CP</p>		<p>32</p> <p>PREREGL</p>	<p>PREREGL</p>
<p>34</p> <p>COM</p>		<p>39</p> <p>TEST5</p>	<p>TEST5</p>
<p>40</p> <p>VREG50</p>			<p>VCC</p> <p>VCCA</p> <p>VREG50</p>

## Operational Notes

### 1. Reverse Connection of Power Supply

Connecting the power supply in reverse polarity can damage the IC. Take precautions against reverse polarity when connecting the power supply, such as mounting an external diode between the power supply and the IC's power supply pins.

### 2. Power Supply Lines

Design the PCB layout pattern to provide low impedance supply lines. Furthermore, connect a capacitor to ground at all power supply pins. Consider the effect of temperature and aging on the capacitance value when using electrolytic capacitors.

### 3. Ground Voltage

Ensure that no pins are at a voltage below that of the ground pin at any time, even during transient condition. However, pins that drive inductive loads (e.g. motor driver outputs, DC-DC converter outputs) may inevitably go below ground due to back EMF or electromotive force. In such cases, the user should make sure that such voltages going below ground will not cause the IC and the system to malfunction by examining carefully all relevant factors and conditions such as motor characteristics, supply voltage, operating frequency and PCB wiring to name a few.

### 4. Ground Wiring Pattern

When using both small-signal and large-current ground traces, the two ground traces should be routed separately but connected to a single ground at the reference point of the application board to avoid fluctuations in the small-signal ground caused by large currents. Also ensure that the ground traces of external components do not cause variations on the ground voltage. The ground lines must be as short and thick as possible to reduce line impedance.

### 5. Recommended Operating Conditions

The function and operation of the IC are guaranteed within the range specified by the recommended operating conditions. The characteristic values are guaranteed only under the conditions of each item specified by the electrical characteristics.

### 6. Inrush Current

When power is first supplied to the IC, it is possible that the internal logic may be unstable and inrush current may flow instantaneously due to the internal powering sequence and delays, especially if the IC has more than one power supply. Therefore, give special consideration to power coupling capacitance, power wiring, width of ground wiring, and routing of connections.

### 7. Testing on Application Boards

When testing the IC on an application board, connecting a capacitor directly to a low-impedance output pin may subject the IC to stress. Always discharge capacitors completely after each process or step. The IC's power supply should always be turned off completely before connecting or removing it from the test setup during the inspection process. To prevent damage from static discharge, ground the IC during assembly and use similar precautions during transport and storage.

### 8. Inter-pin Short and Mounting Errors

Ensure that the direction and position are correct when mounting the IC on the PCB. Incorrect mounting may result in damaging the IC. Avoid nearby pins being shorted to each other especially to ground, power supply and output pin. Inter-pin shorts could be due to many reasons such as metal particles, water droplets (in very humid environment) and unintentional solder bridge deposited in between pins during assembly to name a few.

**Operational Notes – continued**

**9. Unused Input Pins**

Input pins of an IC are often connected to the gate of a MOS transistor. The gate has extremely high impedance and extremely low capacitance. If left unconnected, the electric field from the outside can easily charge it. The small charge acquired in this way is enough to produce a significant effect on the conduction through the transistor and cause unexpected operation of the IC. So unless otherwise specified, unused input pins should be connected to the power supply or ground line.

**10. Regarding the Input Pin of the IC**

This IC contains P+ isolation and P substrate layers between adjacent elements in order to keep them isolated. P-N junctions are formed at the intersection of the P layers with the N layers of other elements, creating a parasitic diode or transistor. For example (refer to figure below):

- When GND > Pin A and GND > Pin B, the P-N junction operates as a parasitic diode.
- When GND > Pin B, the P-N junction operates as a parasitic transistor.

Parasitic diodes inevitably occur in the structure of the IC. The operation of parasitic diodes can result in mutual interference among circuits, operational faults, or physical damage. Therefore, conditions that cause these diodes to operate, such as applying a voltage lower than the GND voltage to an input pin (and thus to the P substrate) should be avoided.

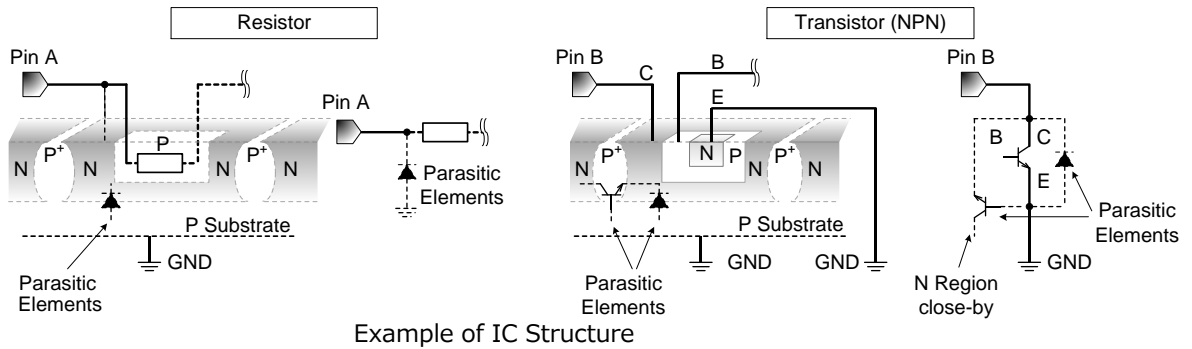

**11. Ceramic Capacitor**

When using a ceramic capacitor, determine a capacitance value considering the change of capacitance with temperature and the decrease in nominal capacitance due to DC bias and others.

**12. Thermal Shutdown Circuit (TSD)**

This IC has a built-in thermal shutdown circuit that prevents heat damage to the IC. Normal operation should always be within the IC’s maximum junction temperature rating. If however the rating is exceeded for a continued period, the junction temperature (Tj) will rise which will activate the TSD circuit that will turn OFF power output pins. When the Tj falls below the TSD threshold, the circuits are automatically restored to normal operation.

Note that the TSD circuit operates in a situation that exceeds the absolute maximum ratings and therefore, under no circumstances, should the TSD circuit be used in a set design or for any purpose other than protecting the IC from heat damage.

**13. Over Current Protection Circuit (OCP)**

This IC incorporates an integrated overcurrent protection circuit that is activated when the load is shorted. This protection circuit is effective in preventing damage due to sudden and unexpected incidents. However, the IC should not be used in applications characterized by continuous operation or transitioning of the protection circuit.

## Ordering Information

B M 6 4 0 7 0 M U V - E 2
---------------------------

Package	MUV:	VQFN040V6060
Packaging	E2:	Embossed carrier tape

## Marking Diagram

VQFN040V6060 (TOP VIEW)

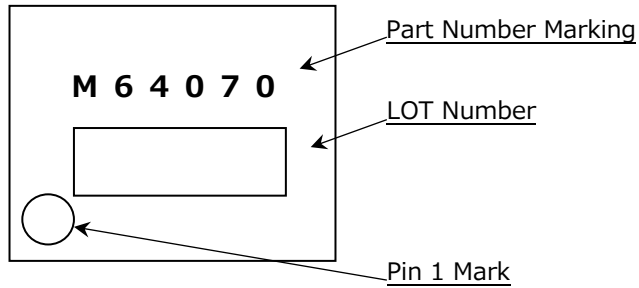

Physical Dimension and Packing Information

Package Name	VQFN040V6060
--------------	--------------

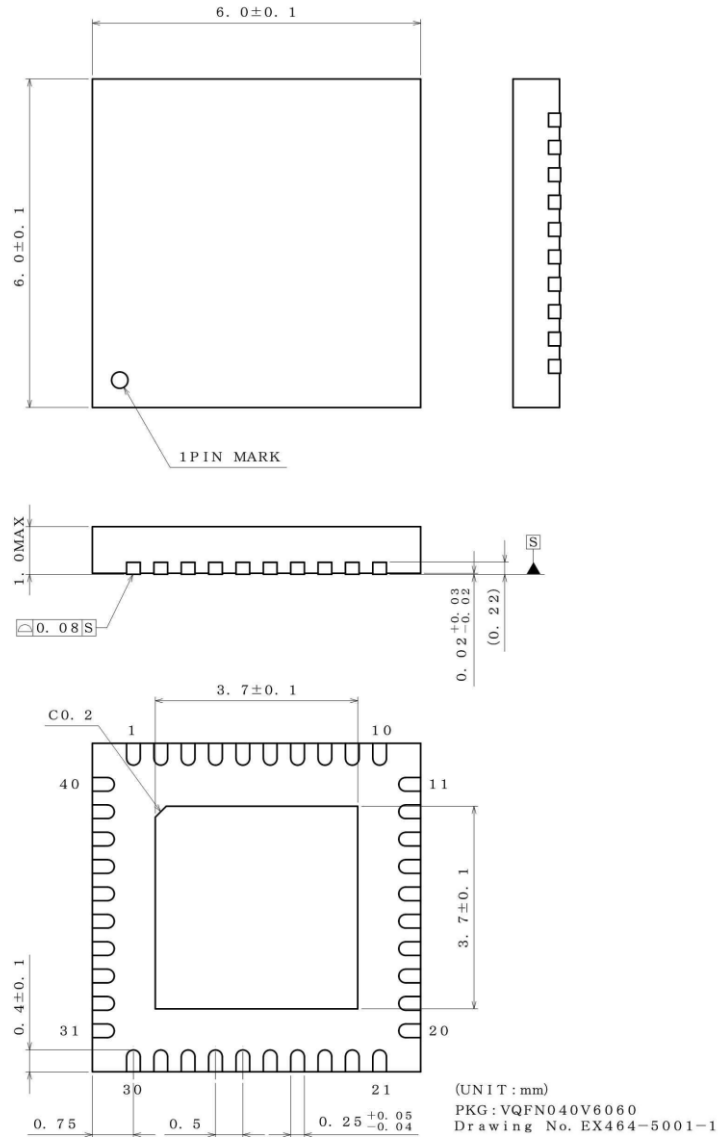

Packing Information	
Packing Form	Embossed carrier tape
Quantity	2000 pcs
Direction of feed	E2

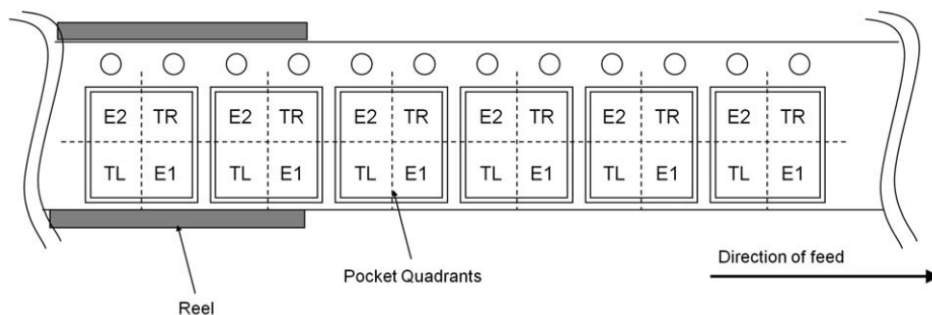

Quadrant Assignments for PIN 1 Orientation in Tape

- E2 : PIN1 is placed to the top left corner.
- TR : PIN1 is placed to the top right corner.
- TL : PIN1 is placed to the lower left.
- E1 : PIN1 is placed to the lower right.

**Revision History**

Date	Revision	Changes
31.Jan.2020	001	New Release

# Notice

## Precaution on using ROHM Products

- Our Products are designed and manufactured for application in ordinary electronic equipment (such as AV equipment, OA equipment, telecommunication equipment, home electronic appliances, amusement equipment, etc.). If you intend to use our Products in devices requiring extremely high reliability (such as medical equipment <sup>(Note 1)</sup>, transport equipment, traffic equipment, aircraft/spacecraft, nuclear power controllers, fuel controllers, car equipment including car accessories, safety devices, etc.) and whose malfunction or failure may cause loss of human life, bodily injury or serious damage to property ("Specific Applications"), please consult with the ROHM sales representative in advance. Unless otherwise agreed in writing by ROHM in advance, ROHM shall not be in any way responsible or liable for any damages, expenses or losses incurred by you or third parties arising from the use of any ROHM's Products for Specific Applications.

(Note1) Medical Equipment Classification of the Specific Applications

JAPAN	USA	EU	CHINA
CLASS III	CLASS III	CLASS II b	CLASS III
CLASS IV		CLASS III	

- ROHM designs and manufactures its Products subject to strict quality control system. However, semiconductor products can fail or malfunction at a certain rate. Please be sure to implement, at your own responsibilities, adequate safety measures including but not limited to fail-safe design against the physical injury, damage to any property, which a failure or malfunction of our Products may cause. The following are examples of safety measures:
  - Installation of protection circuits or other protective devices to improve system safety
  - Installation of redundant circuits to reduce the impact of single or multiple circuit failure
- Our Products are designed and manufactured for use under standard conditions and not under any special or extraordinary environments or conditions, as exemplified below. Accordingly, ROHM shall not be in any way responsible or liable for any damages, expenses or losses arising from the use of any ROHM's Products under any special or extraordinary environments or conditions. If you intend to use our Products under any special or extraordinary environments or conditions (as exemplified below), your independent verification and confirmation of product performance, reliability, etc. prior to use, must be necessary:
  - Use of our Products in any types of liquid, including water, oils, chemicals, and organic solvents
  - Use of our Products outdoors or in places where the Products are exposed to direct sunlight or dust
  - Use of our Products in places where the Products are exposed to sea wind or corrosive gases, including Cl<sub>2</sub>, H<sub>2</sub>S, NH<sub>3</sub>, SO<sub>2</sub>, and NO<sub>2</sub>
  - Use of our Products in places where the Products are exposed to static electricity or electromagnetic waves
  - Use of our Products in proximity to heat-producing components, plastic cords, or other flammable items
  - Sealing or coating our Products with resin or other coating materials
  - Use of our Products without cleaning residue of flux (Exclude cases where no-clean type fluxes is used. However, recommend sufficiently about the residue.) ; or Washing our Products by using water or water-soluble cleaning agents for cleaning residue after soldering
  - Use of the Products in places subject to dew condensation
- The Products are not subject to radiation-proof design.
- Please verify and confirm characteristics of the final or mounted products in using the Products.
- In particular, if a transient load (a large amount of load applied in a short period of time, such as pulse, is applied, confirmation of performance characteristics after on-board mounting is strongly recommended. Avoid applying power exceeding normal rated power; exceeding the power rating under steady-state loading condition may negatively affect product performance and reliability.
- De-rate Power Dissipation depending on ambient temperature. When used in sealed area, confirm that it is the use in the range that does not exceed the maximum junction temperature.
- Confirm that operation temperature is within the specified range described in the product specification.
- ROHM shall not be in any way responsible or liable for failure induced under deviant condition from what is defined in this document.

## Precaution for Mounting / Circuit board design

- When a highly active halogenous (chlorine, bromine, etc.) flux is used, the residue of flux may negatively affect product performance and reliability.
- In principle, the reflow soldering method must be used on a surface-mount products, the flow soldering method must be used on a through hole mount products. If the flow soldering method is preferred on a surface-mount products, please consult with the ROHM representative in advance.

For details, please refer to ROHM Mounting specification

### Precautions Regarding Application Examples and External Circuits

1. If change is made to the constant of an external circuit, please allow a sufficient margin considering variations of the characteristics of the Products and external components, including transient characteristics, as well as static characteristics.
2. You agree that application notes, reference designs, and associated data and information contained in this document are presented only as guidance for Products use. Therefore, in case you use such information, you are solely responsible for it and you must exercise your own independent verification and judgment in the use of such information contained in this document. ROHM shall not be in any way responsible or liable for any damages, expenses or losses incurred by you or third parties arising from the use of such information.

### Precaution for Electrostatic

This Product is electrostatic sensitive product, which may be damaged due to electrostatic discharge. Please take proper caution in your manufacturing process and storage so that voltage exceeding the Products maximum rating will not be applied to Products. Please take special care under dry condition (e.g. Grounding of human body / equipment / solder iron, isolation from charged objects, setting of Ionizer, friction prevention and temperature / humidity control).

### Precaution for Storage / Transportation

1. Product performance and soldered connections may deteriorate if the Products are stored in the places where:
  - [a] the Products are exposed to sea winds or corrosive gases, including Cl<sub>2</sub>, H<sub>2</sub>S, NH<sub>3</sub>, SO<sub>2</sub>, and NO<sub>2</sub>
  - [b] the temperature or humidity exceeds those recommended by ROHM
  - [c] the Products are exposed to direct sunshine or condensation
  - [d] the Products are exposed to high Electrostatic
2. Even under ROHM recommended storage condition, solderability of products out of recommended storage time period may be degraded. It is strongly recommended to confirm solderability before using Products of which storage time is exceeding the recommended storage time period.
3. Store / transport cartons in the correct direction, which is indicated on a carton with a symbol. Otherwise bent leads may occur due to excessive stress applied when dropping of a carton.
4. Use Products within the specified time after opening a humidity barrier bag. Baking is required before using Products of which storage time is exceeding the recommended storage time period.

### Precaution for Product Label

A two-dimensional barcode printed on ROHM Products label is for ROHM's internal use only.

### Precaution for Disposition

When disposing Products please dispose them properly using an authorized industry waste company.

### Precaution for Foreign Exchange and Foreign Trade act

Since concerned goods might be fallen under listed items of export control prescribed by Foreign exchange and Foreign trade act, please consult with ROHM in case of export.

### Precaution Regarding Intellectual Property Rights

1. All information and data including but not limited to application example contained in this document is for reference only. ROHM does not warrant that foregoing information or data will not infringe any intellectual property rights or any other rights of any third party regarding such information or data.
2. ROHM shall not have any obligations where the claims, actions or demands arising from the combination of the Products with other articles such as components, circuits, systems or external equipment (including software).
3. No license, expressly or implied, is granted hereby under any intellectual property rights or other rights of ROHM or any third parties with respect to the Products or the information contained in this document. Provided, however, that ROHM will not assert its intellectual property rights or other rights against you or your customers to the extent necessary to manufacture or sell products containing the Products, subject to the terms and conditions herein.

### Other Precaution



1. This document may not be reprinted or reproduced, in whole or in part, without prior written consent of ROHM.
2. The Products may not be disassembled, converted, modified, reproduced or otherwise changed without prior written consent of ROHM.
3. In no event shall you use in any way whatsoever the Products and the related technical information contained in the Products or this document for any military purposes, including but not limited to, the development of mass-destruction weapons.
4. The proper names of companies or products described in this document are trademarks or registered trademarks of ROHM, its affiliated companies or third parties.

**General Precaution**







1. Before you use our Products, you are requested to carefully read this document and fully understand its contents. ROHM shall not be in any way responsible or liable for failure, malfunction or accident arising from the use of any ROHM's Products against warning, caution or note contained in this document.
2. All information contained in this document is current as of the issuing date and subject to change without any prior notice. Before purchasing or using ROHM's Products, please confirm the latest information with a ROHM sales representative.
3. The information contained in this document is provided on an "as is" basis and ROHM does not warrant that all information contained in this document is accurate and/or error-free. ROHM shall not be in any way responsible or liable for any damages, expenses or losses incurred by you or third parties resulting from inaccuracy or errors of or concerning such information.

## Looking for pricing, stock, or lifecycle information?

Click below to explore more details on WIN SOURCE:

-  [View BM64070MUV-E2 on WIN SOURCE](#)
-  [Rohm Semiconductor](#) Information

## Optimize Your Supply Chain with WIN SOURCE Solutions

-  Global Sourcing Solution
-  Obsolete Management
-  Cost Control Management
-  Shortage Management
-  Alternative Solution
-  Excess Inventory Management