



**THE DATASHEET OF
B2102UDUG20C000133U1930**



**Harvatek Surface Mount CHIP LEDs Approval Sheet
B2102UDUG20C000133U1930**

Official Product	HT Part No. B2102UDUG20C000133U1930		
Tentative Product	*****	*****	
Specifications are subject to changes for improvement without advance notice. Proprietary data, drawings, and company confidential all rights reserved.	03/12/2021	Version of 1.3	Page 1/14

DISCLAIMER 3

PRODUCT SPECIFICATION 4

ATTENTION: ELECTRICSTATIC DISCHARGE (ESD) PROTECTION..... 4

LABEL SPEC.: 5

PRODUCT SPECIFICATIONS..... 6

PRODUCT FEATURE 7

ELECTRO-OPTICAL CHARACTERISTICS..... 7

PACKAGE OUTLINE DIMENSION AND RECOMMENDED SOLDERING PATTERN FOR REFLOW

SOLDERING 7

ABSOLUTE MAXIMUM RATINGS 7

PRECAUTION FOR USE 8

CHARACTERISTICS OF B2102UDUG 9

PACKAGING TAPE, REEL, AND PACKING MODEL 10

TAPE DIMENSION 10

REEL DIMENSION 11

PACKING 11

DRY PACK..... 12

BAKING..... 12

PRECAUTIONS 12

REFLOW SOLDERING 13

REWORKING..... 13

CLEANING 13

REVISE HISTORY..... 14

Official Product	HT Part No. B2102UDUG20C000133U1930		
Tentative Product	*****	*****	
Specifications are subject to changes for improvement without advance notice. Proprietary data, drawings, and company confidential all rights reserved.	03/12/2021	Version of 1.3	Page 2/14

DISCLAIMER

HARVATEK reserves the right to make changes without further notice to any products herein to improve reliability, function or design. HARVATEK does not assume any liability arising out of the application or use of any product or circuit described herein; neither does it convey any license under its patent rights, nor the rights of others.

LIFE SUPPORT POLICY

HARVATEK’s products are not authorized for use as critical components in life support devices or systems without the express written approval of the President of HARVATEK or HARVATEK INTERNATIONAL. As used herein:

1. Life support devices or systems are devices or systems which, (a) are intended for surgical implant into the body, or (b) support or sustain life, and (c) whose failure to perform when properly used in accordance with instructions for use provided in the labeling, can be reasonably expected to result in a significant injury of the user.

2. A critical component in any component of a life support device or system whose failure to perform can be reasonably expected to cause the failure of the life support device or system, or to affect its safety or effectiveness.

Official Product	HT Part No. B2102UDUG20C000133U1930		
Tentative Product	*****	*****	
Specifications are subject to changes for improvement without advance notice. Proprietary data, drawings, and company confidential all rights reserved.	03/12/2021	Version of 1.3	Page 3/14

Product Specification

	Specification	Material	Quantity
Luminous Intensity(Iv)	UD:45.0-180.0 mcd UG:45.0-180.0 mcd @20mA/ T _s = 25°C;Tolerance: ± 10%		
Wavelength	UD: 600.0-612.0 nm UG : 567.5-579.5 nm @20mA/ T _s = 25°C;Tolerance: ± 0.5nm		
Vf	UD: 1.6-2.4 V UG: 1.6-2.4 V @20mA/ T _s = 25°C ;Tolerance: ± 0.05V		
Ir	< 10 μA @ V _R = 5 V		
Resin	Clear	Epoxy resin	
Carrier tape	According to EIA 481-1A specs	Conductive tape	3000pcs per reel
Reel	According to EIA 481-1A specs	Plastic/ White	
Label	HT standard	Paper	
Packing bag	220x240mm	Aluminum laminated bag/ no-zipper	One reel one bag
Carton	HT standard	Paper	Non-specified

Others:

Every mid-box will be loaded 5 reels. These 5 reels can be different in lot, Iv, lambda, or Vf. Every reel will have an independent label to identify its specification and the mid-box there will have a corresponding label post on it.

ATTENTION: Electricstatic Discharge (ESD) protection



The symbol shown on the page herein to introduce 'Electro-Optical Characteristics'. ESD protection for GaP and AlGaAs based chips is still necessary even though they are safe in low static-electric discharge. Parts built with AllnGaP, GaN, or/and InGaN based chips are **STATIC SENSITIVE devices**. ESD protection has to be considered and taken in the initial design stage.

If manual work/process is needed, please ensure the device is well protected from ESD during all the process.

Official Product	HT Part No. B2102UDUG20C000133U1930		
Tentative Product	*****	*****	
Specifications are subject to changes for improvement without advance notice. Proprietary data, drawings, and company confidential all rights reserved.	03/12/2021	Version of 1.3	Page 4/14

Label Spec.:



Customer P/N: To Be Defined:

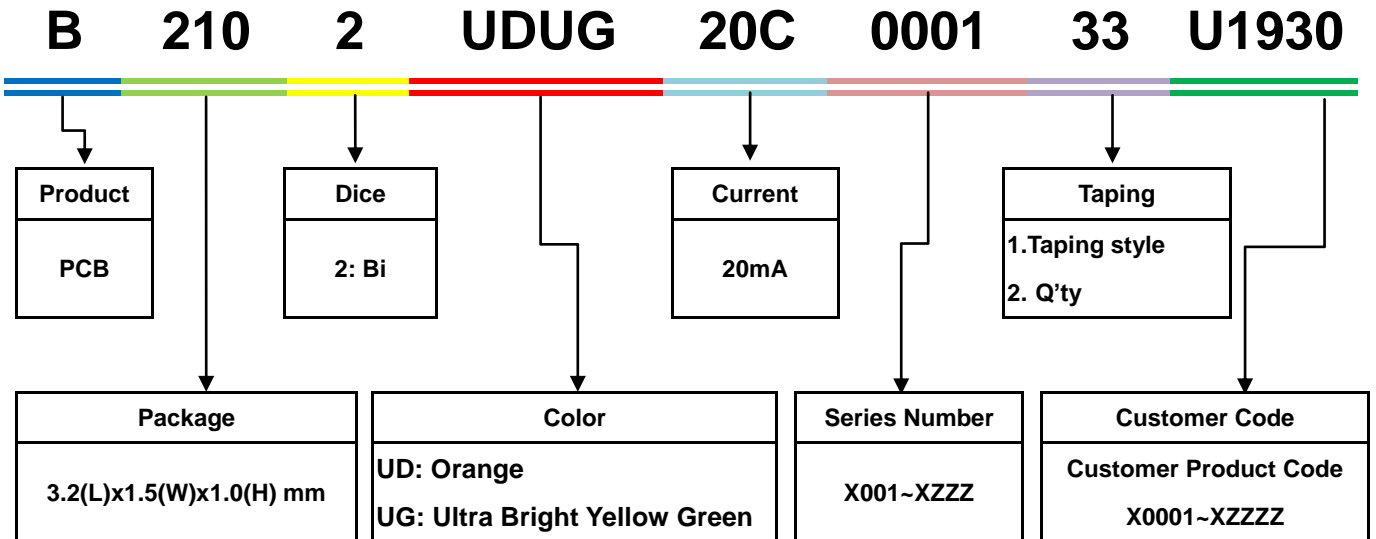

Lot No.

1	2	3	4	5	6	7	8	9	10
E	1	A	1	A	2	2	L	1	2
Code 1 2		Code 3	Code 4	Code 5	Code 6	Code 7	Code 8	Code 9	Code 10
		Mfg. Year	Mfg. Month	Mfg. Date	Consecutive number		Special code		
Internal Tracing Code		2010-A		1:A	01-ZZ		000-ZZZ		
		2011-B		2:B					
		2012-C	1:Jan.	3:C					
		...	2:Feb.	...					
		2018-I/J	...	26:Z					
		2019-K	A:Oct.	27:7					
		...	B:Nov.	28:8					
2022-N	C:Dec.	29:9							
2023-P		30:3							
		...		31:4					

Official Product	HT Part No. B2102UDUG20C000133U1930			
Tentative Product	*****		*****	
Specifications are subject to changes for improvement without advance notice. Proprietary data, drawings, and company confidential all rights reserved.	03/12/2021	Version of 1.3	Page 5/14	

Product specifications

■ **Luminous Intensity (Iv) Bin:**

Color	Bin Code	Spec. Range
UD	P	45.00-71.50 mcd
	Q	71.50-112.5 mcd
	R	112.5-180.0 mcd
UG	P	45.00-71.50 mcd
	Q	71.50-112.5 mcd
	R	112.5-180.0 mcd

Note: It maintains a tolerance of ±10% on luminous intensity

■ **Wavelength Bin:**

Color	Bin Code	Spec. Range
UD	B	600.0-603.0 nm
	C	603.0-606.0 nm
	D	606.0-609.0 nm
	E	609.0-612.0 nm
UG	C	567.5-570.5 nm
	D	570.5-573.5 nm
	E	573.5-576.5 nm
	F	576.5-579.5 nm

Note: It maintains a tolerance of ± 0.5nm on Wavelength Bin

■ **Forward Voltage (Vf) Bin:**

Color	Bin Code	Spec. Range
UD	E18	1.6-2.4 V
UG	E18	1.6-2.4 V

Note: It maintains a tolerance of ±0.05V on forward voltage measurements

Official Product	HT Part No. B2102UDUG20C000133U1930		
Tentative Product	*****	*****	
Specifications are subject to changes for improvement without advance notice. Proprietary data, drawings, and company confidential all rights reserved.	03/12/2021	Version of 1.3	Page 6/14

Product Feature

Electro-Optical Characteristics

(T_{Soldering} 25 °C)

Series	Emitting Color	Material	V _F (V)		Wavelength λ(nm)			I _v (mcd)	Viewing
			typ	max	λ _D	λ _P	Δ λ	Typical	Angle 2θ _{1/2}
B2102UDUG20	UD	AlGaInP	2.0	2.4	605	611	17	71.5	X=130 Y=100
	UG	AlGaInP	2.1	2.4	571	573	15	71.5	X=124 Y=115

Package Outline Dimension and Recommended Soldering Pattern for Reflow Soldering

Unit: mm Tolerance: +/-0.1

Outline Dim.	Suggest Soldering Pattern
Soldering terminal may shift in x, y direction.	

Absolute Maximum Ratings

(T_{Soldering} 25 °C)

Series	P _D (mW)	I _F (mA)	I _{FP} (mA)*	T _{OP} (°C)	T _{ST} (°C)
Color	Power Dissipation	Forward Current	Pulse Forward Current	Operating Temperature	Storage Temperature
UD	48	20	100	-40~+85	-40~+100
UG	48	20	100	-40~+85	-40~+100

*Condition for I_{FP} is pulse of 1/10 duty and 0.1msec width

Official Product	HT Part No. B2102UDUG20C000133U1930		
Tentative Product	*****	*****	
Specifications are subject to changes for improvement without advance notice. Proprietary data, drawings, and company confidential all rights reserved.	03/12/2021	Version of 1.3	Page 7/14

Precaution for Use

1. The chips should not be used directly in any type of fluid such as water, oil, organic solvent, etc.
2. When the LEDs are illuminating, the maximum ambient temperature should be first considered before operation.
3. LEDs must be stored in a clean environment. A sealed container with a nitrogen atmosphere is necessary if the storage period is over 3 months after shipping.
4. The LEDs must be used within 4 weeks after unpacked. Unused products must be repacked in an anti-electrostatic package, folded to close any opening and then stored in a dry and cool space.
5. The appearance and specifications of the products may be modified for improvement without further notice.
6. The LEDs are sensitive to the static electricity and surge. It is strongly recommended to use a grounded wrist band and anti-electrostatic glove when handling the LEDs. If a voltage over the absolute maximum rating is applied to LEDs, it will damage LEDs. Damaged LEDs will show some abnormal characteristics such as remarkable increase of leak current, lower turn-on voltage and getting unlit at low current.

Official Product	HT Part No. B2102UDUG20C000133U1930		
Tentative Product	*****	*****	
Specifications are subject to changes for improvement without advance notice. Proprietary data, drawings, and company confidential all rights reserved.	03/12/2021	Version of 1.3	Page 8/14

Characteristics of B2102UDUG

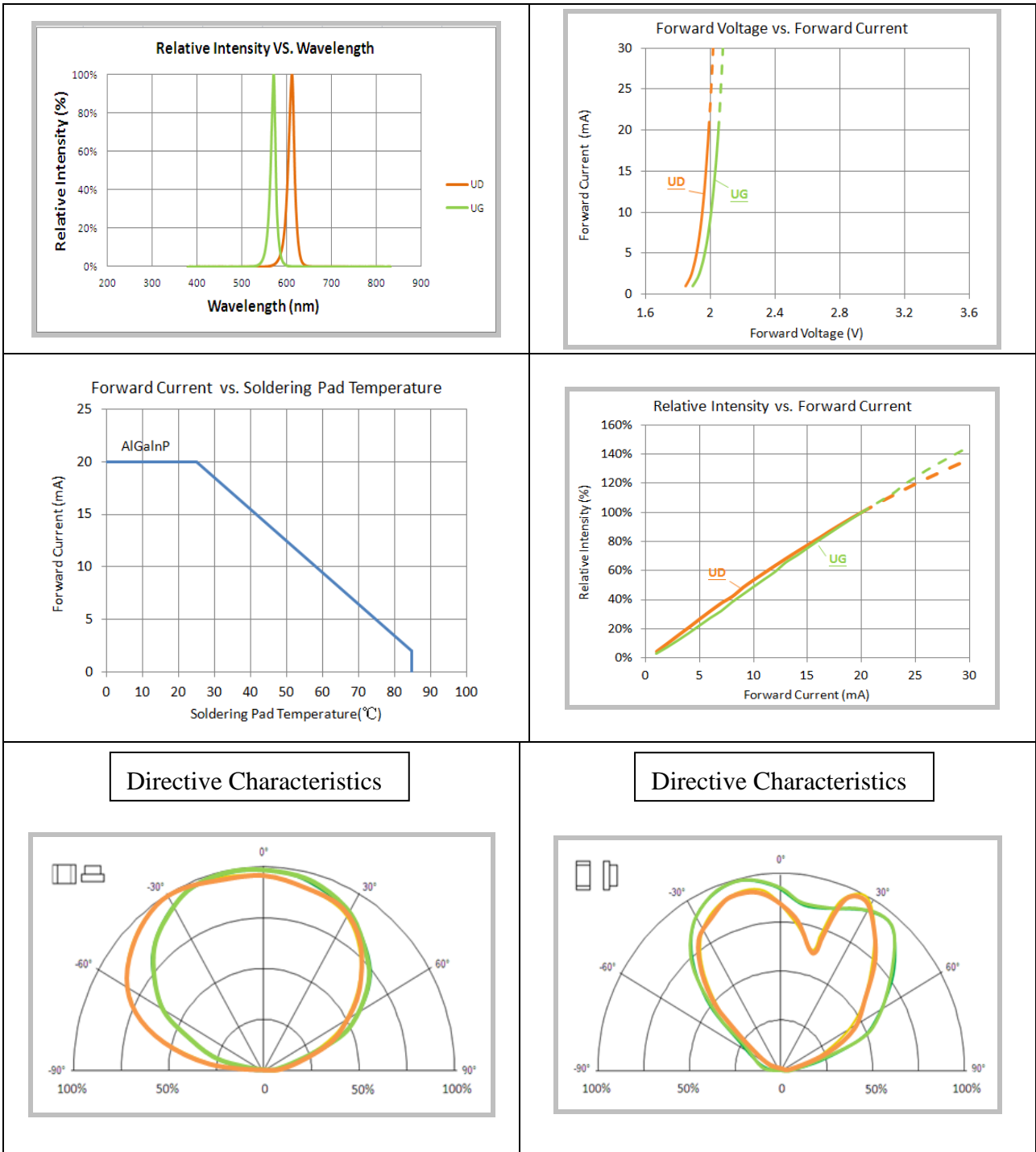

Official Product	HT Part No. B2102UDUG20C000133U1930		
Tentative Product	*****	*****	
Specifications are subject to changes for improvement without advance notice. Proprietary data, drawings, and company confidential all rights reserved.	03/12/2021	Version of 1.3	Page 9/14

Packaging Tape, Reel, and Packing Model Tape Dimension

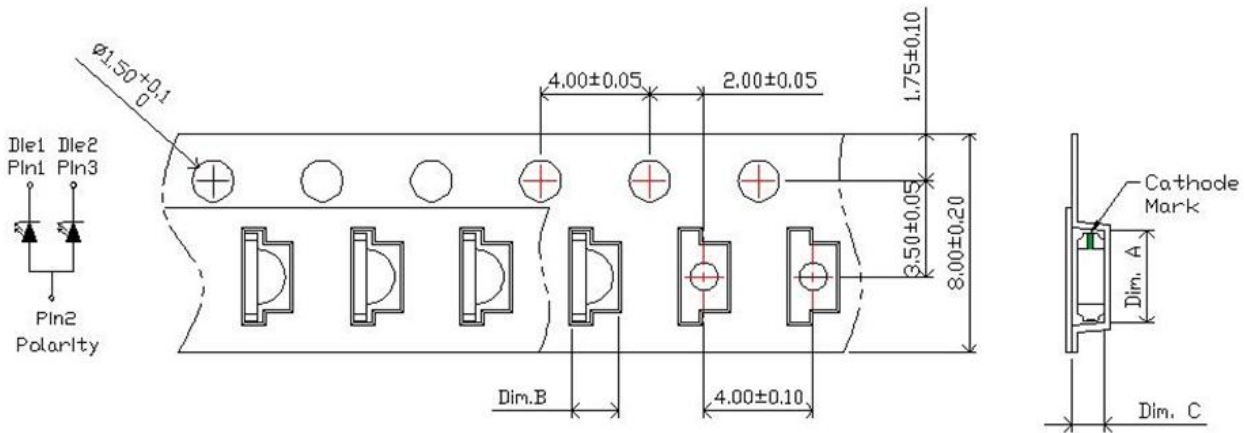

Dim. A	Dim. B	Dim. C	Q'ty/Reel
3.40 ± 0.10	1.70 ± 0.10	1.20 ± 0.10	3K

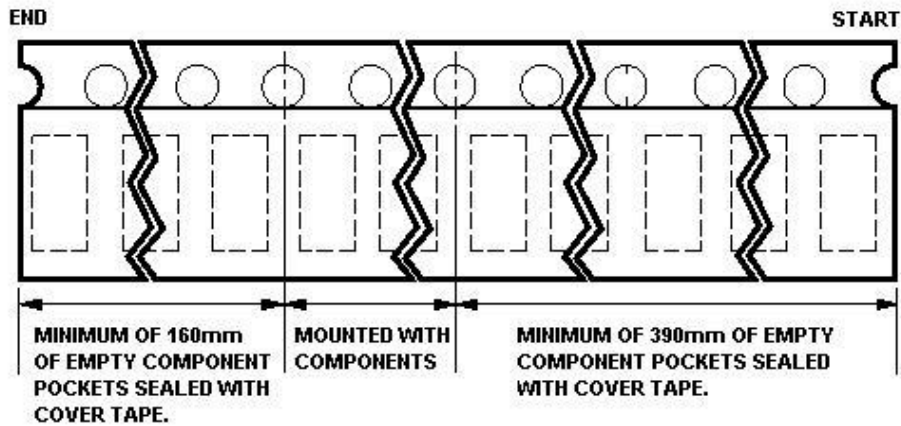

Official Product	HT Part No. B2102UDUG20C000133U1930		
Tentative Product	*****	*****	
Specifications are subject to changes for improvement without advance notice. Proprietary data, drawings, and company confidential all rights reserved.	03/12/2021	Version of 1.3	Page 10/14

Reel Dimension

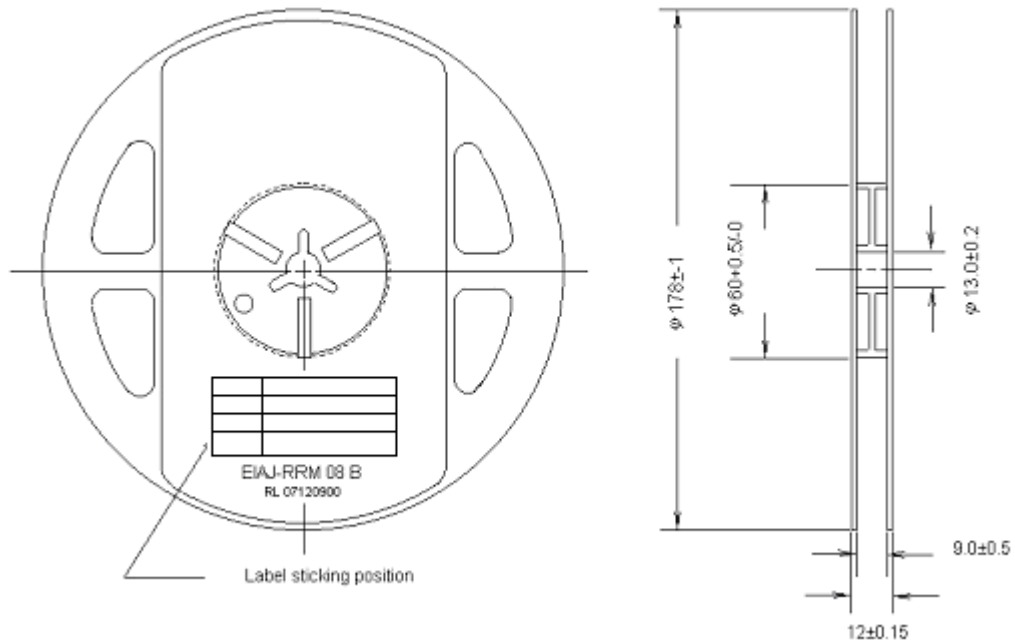

Packing

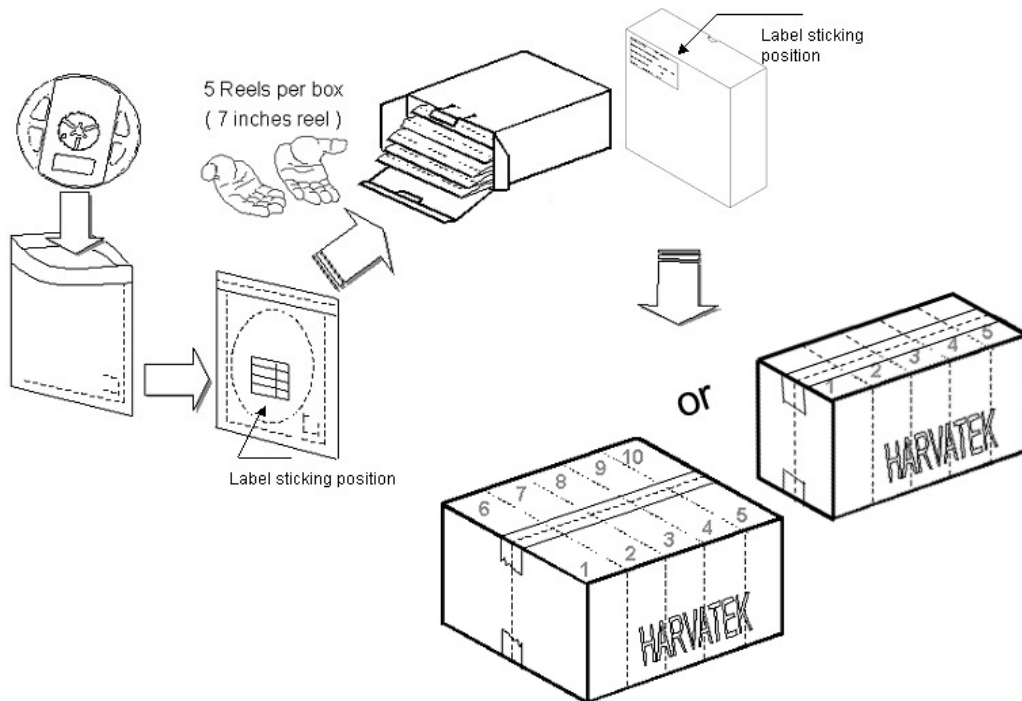

5 or 10 boxes per carton is available depending on shipment quantity.

Official Product	HT Part No. B2102UDUG20C000133U1930		
Tentative Product	*****	*****	
Specifications are subject to changes for improvement without advance notice. Proprietary data, drawings, and company confidential all rights reserved.	03/12/2021	Version of 1.3	Page 11/14

Dry Pack

All SMD optical devices are **MOISTURE SENSITIVE**. Avoid exposure to moisture at all times during transportation or storage. Every reel is packaged in a moisture protected anti-static bag. Each bag is properly sealed prior to shipment.

A humidity indicator will be included in the moisture protected anti-static bag prior to shipment.

The packaging sequence is as follows:

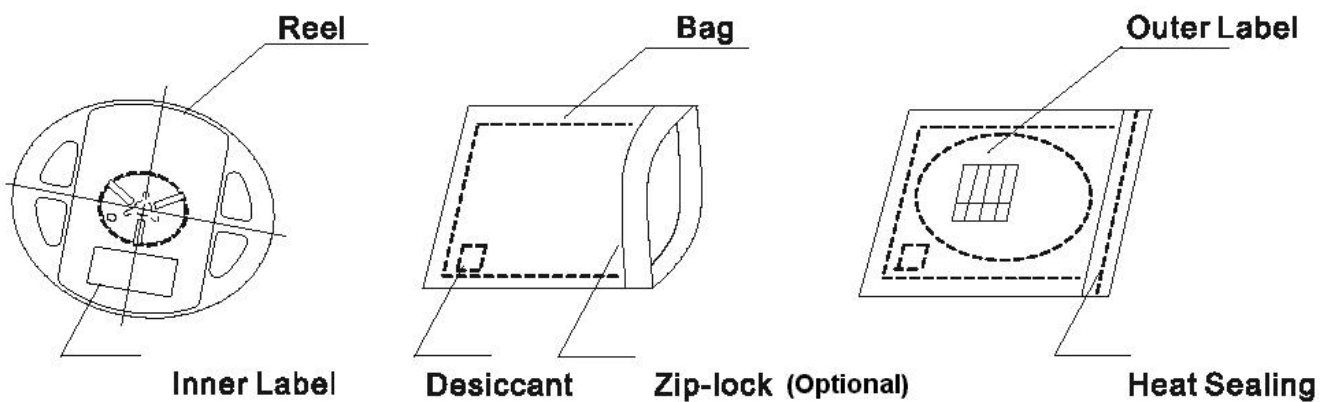

Baking

Baking before soldering is recommended when the package has been unsealed for 4 weeks.

The conditions are as followings:

1. 60±3°C x(12~24hrs)and<5%RH, taped reel type.
2. 100±3°C x(45min~1hr), bulk type.
3. 130±3°C x(15min~30min), bulk type.

Precautions

1. Avoid exposure to moisture at all times during transportation or storage.
2. Anti-Static precaution must be taken when handling GaN, InGaN, and AlGaInP products.
3. It is suggested to connect the unit with a current limiting resistor of the proper size. Avoid applying a reverse voltage beyond the specified limit.
4. Avoid operation beyond the limits as specified by the absolute maximum ratings.
5. Avoid direct contact with the surface through which the LED emits light.
6. If possible, assemble the unit in a clean room or dust-free environment.

Official Product	HT Part No. B2102UDUG20C000133U1930		
Tentative Product	*****	*****	
Specifications are subject to changes for improvement without advance notice. Proprietary data, drawings, and company confidential all rights reserved.	03/12/2021	Version of 1.3	Page 12/14

Reflow Soldering

Recommend soldering paste specifications:

1. Operating temp.: Above 217°C ,60~150 sec.
2. Peak temp.:260 °C Max.,10sec Max.
3. Reflow soldering should not be done more than two times.
4. Never attempt next process until the component is cooled down to room temperature after reflow.
5. The recommended reflow soldering profile (measured on the surface of the LED terminal) is as following:

Lead-free Solder Profile

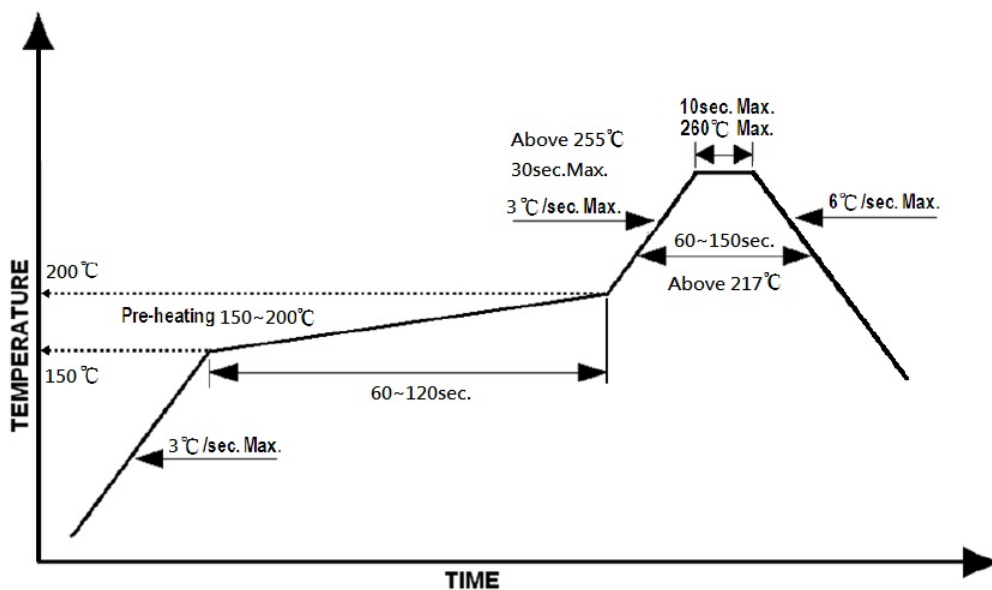

Reworking

- Rework should be completed within 5 seconds under 260 °C.
- The iron tip must not come in contact with the copper foil.
- Twin-head type is preferred.

Cleaning

Following are cleaning procedures after soldering:

- An alcohol-based solvent such as isopropyl alcohol (IPA) is recommended.
- Temperature x Time should be 50°C x 30sec. or <30°C x 3min
- Ultra sonic cleaning: < 15W/ bath; bath volume ≤ 1liter
- Curing: 100 °C max, <3min

Official Product	HT Part No. B2102UDUG20C000133U1930		
Tentative Product	*****	*****	
Specifications are subject to changes for improvement without advance notice. Proprietary data, drawings, and company confidential all rights reserved.	03/12/2021	Version of 1.3	Page 13/14

Looking for pricing, stock, or lifecycle information?

Click below to explore more details on WIN SOURCE:

-  [View B2102UDUG20C000133U1930 on WIN SOURCE](#)
-  [Harvatek Information](#)

Optimize Your Supply Chain with WIN SOURCE Solutions

-  Global Sourcing Solution
-  Obsolete Management
-  Cost Control Management
-  Shortage Management
-  Alternative Solution
-  Excess Inventory Management