



**THE DATASHEET OF
SSL2109T/1,118**





SSL2109T

Compact non-dimmable LED driver IC

Rev. 5 — 3 October 2013

Product data sheet

1. General description

The SSL2109T is a high-voltage Integrated Circuit (IC) for driving LED lamps in general lighting applications.

The main benefits of this IC include:

- Small Printed-Circuit Board (PCB) footprint and compact solution
- High efficiency (up to 95 %) for non-dimmable high power factor solutions
- High power factor >0.9 (application dependent)
- Ease of integration and many protection features
- Low electronic Bill Of Material (BOM)
- Highly flexible IC for use in buck, buck/boost and flyback modes
- Single inductor used for non-isolated configurations because of internal demagnetization detection and dV/dt supply

The IC is supplementary to the SSL21081/SSL21083 series but without an internal switch. The IC has been designed to start up directly from the HV supply by an internal high-voltage current source. Thereafter, the dV/dt supply is used with capacitive coupling from the drain, or any other auxiliary supply. This functionality provides full flexibility in the application design. An internal clamp limits the supply voltage.

The IC provides accurate output current control to within 5 % LED current accuracy. The IC can be operated using Pulse-Width Modulation (PWM) current regulation and has many protection features including easy LED temperature feedback.

2. Features and benefits

- LED driver IC for driving strings of LEDs or high-voltage LED modules from a rectified mains supply
- Part of a high-efficiency switch mode flyback or buck product family.
 - ◆ Driver-only which can drive an external MOSFET
- Driver that has power-efficient boundary conduction mode of operation with:
 - ◆ No reverse recovery losses in freewheel diode
 - ◆ Zero Current Switching (ZCS) for switch turn-on
 - ◆ Zero voltage or valley switching for switch turn-off
 - ◆ Minimal required inductance value and size
- Suitable for high power factor (>0.9) applications
- Applicable in buck, buck/boost and flyback topologies



- Direct PWM current regulation possible
- Fast transient response through cycle-by-cycle current control:
 - ◆ Negligible AC mains ripple in LED current and minimal total capacitance in low ripple configurations
 - ◆ No over or undershoots in the LED current
- Simple high input power factor solution (>0.9)
- Internal protection features:
 - ◆ UnderVoltage LockOut (UVLO)
 - ◆ Leading-Edge Blanking (LEB)
 - ◆ OverCurrent Protection (OCP)
 - ◆ Short-Winding Protection (SWP)
 - ◆ Internal OverTemperature Protection (OTP)
 - ◆ Brownout protection
 - ◆ Output Short Protection (OSP)
- Low component count LED driver solution (see [Figure 3](#)):
 - ◆ Easy external temperature protection with a single NTC
 - ◆ Option for soft-start function
 - ◆ Compatible with wall switches with built-in indication light during standby
- IC lifetime easily matches or surpasses LED lamp lifetime

3. Applications

The SSL2109T is intended for compact LED lamps with accurate fixed current output for single mains input voltages. Mains input voltages include 100 V, 120 V and 230 V (AC). The output signal can be modulated using a PWM signal. External components determine the power range.

4. Quick reference data

Table 1. Quick reference data

Symbol	Parameter	Conditions	Min	Typ	Max	Unit
V_{CC}	supply voltage	operating range [1]	8	-	16	V
$I_{CC(INT)}$	internal supply current	normal operation	-	1.3	-	mA
V_{HV}	voltage on pin HV		-0.4	-	+600	V
V_{DRAIN}	voltage on pin DRAIN		-0.4	-	+600	V
f_{conv}	conversion frequency		-	100	-	kHz
$V_{O(DRIVER)max}$	maximum output voltage on pin DRIVER	$V_{CC} > V_{CC(startup)}$	9	10.5	12	V

[1] An internal clamp sets the supply voltage. The current into the VCC pin must not exceed the maximum IDD value (see [Table 4](#))

5. Ordering information

Table 2. Ordering information

Type number	Package		Version
	Name	Description	
SSL2109T	SO8	plastic small package outline body; 8 leads; body width 3.9 mm	SOT96-1

6. Block diagram

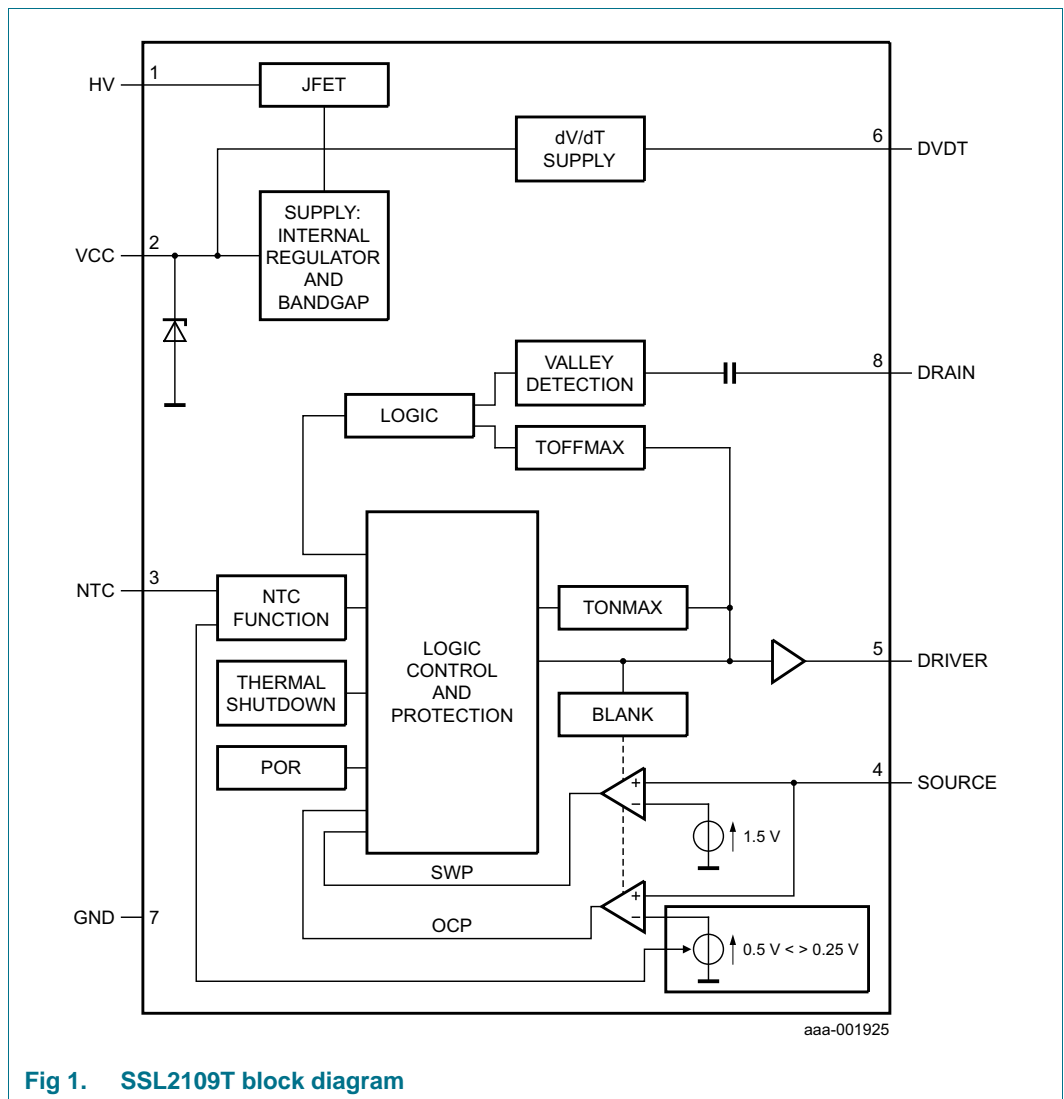
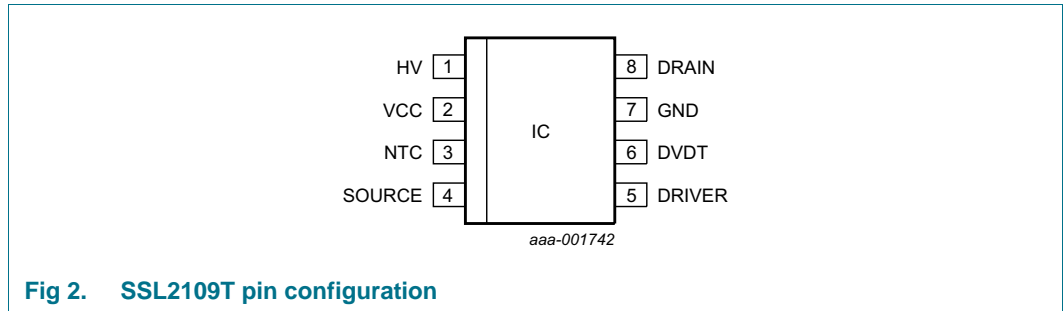

Fig 1. SSL2109T block diagram

7. Pinning information

7.1 Pinning



7.2 Pin description

Table 3. Pin description

Symbol	Pin	Description
HV	1	high-voltage supply pin
VCC	2	supply voltage
NTC	3	temperature protection input
SOURCE	4	low-side external switch
DRIVER	5	driver output
DVDT	6	AC supply pin
GND	7	ground
DRAIN	8	high-side external switch

8. Functional description

8.1 Introduction

The SSL2109T is a driver for small form factor retrofit SSL lamps and separate LED drivers.

8.2 Converter operation

The converter in the SSL2109T is a Boundary Conduction Mode (BCM), peak current controlled system. [Figure 3](#) shows the basic application diagram. [Figure 4](#) shows the waveforms.

This converter type operates at the boundary between continuous and discontinuous mode. Energy is stored in inductor L each period that the switch is on. The inductor current I_L is zero when the MOSFET is switched on. The amplitude of the current build-up in L is proportional to the voltage drop over the inductor and the time that the MOSFET switch is on. When the MOSFET is switched off, the energy in the inductor is released towards the output. The current then falls at a rate proportional to the value of V_{OUT} . The LED current I_{LED} depends on the peak current through the inductor (SSL2109T controlled) and on the HV bus voltage while it is optimized for a high power factor. As soon as the inductor current I_L is zero, a new cycle is started. This quasi-resonant operation results in higher efficiency.

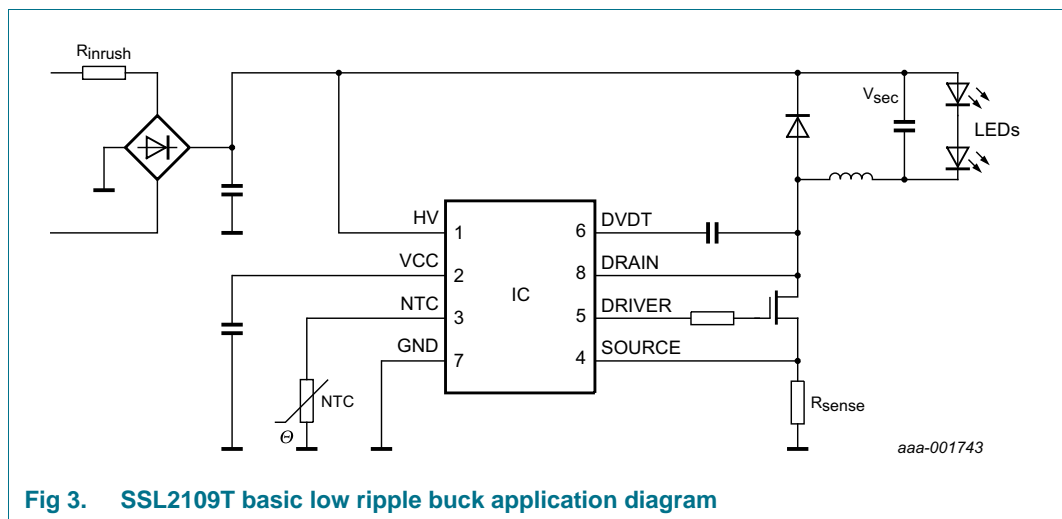

Fig 3. SSL2109T basic low ripple buck application diagram

8.3 Driver pin

The SSL2109T is equipped with an internal driver that can control an external switch. The voltage on the driver output pin is increased towards $V_{O(DRIVER)max}$ to open the switch during the first cycle (t_0 to t_1). The voltage on the driver output pin is pulled down towards a low level from the start of the secondary stroke until the next cycle starts (t_0 to t_{00}). During transition from low to high and back, there is a controlled switching slope steepness. This controlled condition limits the high-frequency radiation from the circuit to the surrounding area.

At the lowest VCC voltage ($V_{CC(stop)}$), the voltage of the driver is $V_{O(DRIVER)min}$.

8.4 Valley detection

A new cycle is started when the primary switch is switched on (see Figure 4). In the following sections, “on” represents the conductive state and off the non-conductive state.

Following time t_1 , when the peak current is detected on the SOURCE pin, the switch is turned off and the secondary stroke starts at t_2 . When the secondary stroke is completed with the coil current at t_3 equaling zero, the drain voltage starts to oscillate at approximately $V_{IN} - V_{OUT}$ level. The peak-to-peak amplitude equals $2 \times V_{OUT}$. A special feature, called valley detection is an integrated part of the SSL2109T circuitry. Dedicated built-in circuitry connected to the DRAIN pin, senses when the voltage on the drain of the switch has reached its lowest value. The next cycle is then started at t_{00} . As a result the capacitive switching losses are reduced.

If both the frequency of the oscillations and the voltage swing are within the range specified (f_{ring} and $\Delta V_{vrec(min)}$) for detection, a valley is detected and accepted. If a valid valley is not detected, the secondary stroke is continued until the maximum off-time ($t_{off(high)}$) is reached. Then the next cycle is started.

A series resistance can be included at the drain sensing pin for flyback mode to remove the high-frequency ringing caused by the transformer leakage inductance.

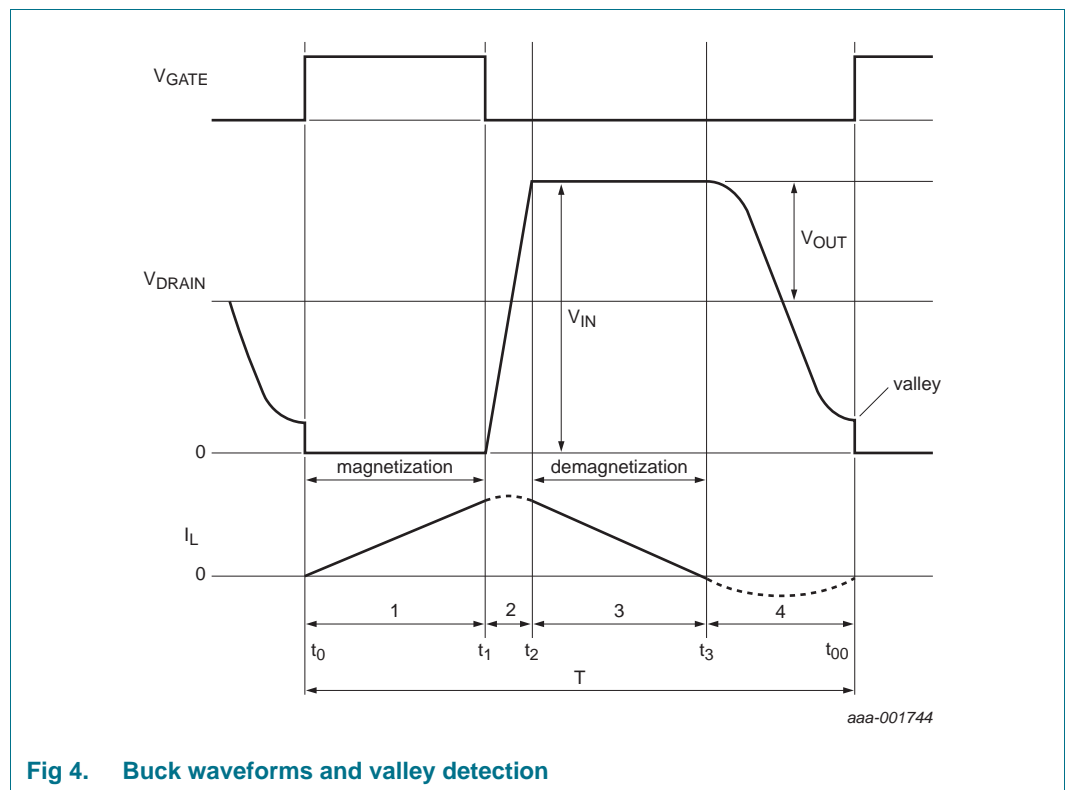

Fig 4. Buck waveforms and valley detection

8.5 Protective features

The IC has the following protections:

- UnderVoltage LockOut (UVLO)
- Leading-Edge Blanking (LEB)
- OverCurrent Protection (OCP)
- Internal OverTemperature Protection (OTP)
- Brownout protection
- Short-Winding Protection (SWP)
- Output Short Protection (OSP)
- LED overtemperature control and protection

The SWP and the OSP are latched protections. These protections cause the IC to halt until a reset (a result of power cycling) is executed. When V_{CC} drops to below $V_{CC(rst)}$, the IC resets the latch protection mode. The internal OTP and LED over temperature protections are safe-restart protections. If V_{CC} drops to below $V_{CC(stop)}$, the IC halts. Switching starts only when a no fault condition exists.

8.5.1 UnderVoltage LockOut (UVLO)

When the voltage on the VCC pin drops lower than $V_{CC(stop)}$, the IC stops switching. An attempt is made to restart by supplying V_{CC} from the HV pin voltage.

8.5.2 Leading-Edge Blanking (LEB)

To prevent false detection of the short-winding or overcurrent, a blanking time following switch-on is implemented. When the MOSFET switch switches on, there can be a short current spike due to capacitive discharge of voltage over the drain and source and the charging of the gate to source capacitance. During the LEB time (t_{leb}), the spike is disregarded.

8.5.3 OverCurrent Protection (OCP)

The SSL2109T contains a highly accurate peak current detector. It triggers when the voltage at the SOURCE pin reaches the peak-level $V_{th(ocp)SOURCE}$. The current through the switch is sensed using a resistor connected to the SOURCE pin. The sense circuit is activated following LEB time t_{leb} . As the LED current is half the peak current (by design), it automatically provides protection for maximum LED current during operation. There is a propagation delay ($t_{d(ocp-swoff)}$) between the overcurrent detection and the actual switching off of the switch. Due to the delay, the actual peak current is slightly higher than the OCP level set using the resistor in series to the SOURCE pin.

8.5.4 OverTemperature Protection (OTP)

When the internal OTP function is triggered at a certain IC temperature ($T_{th(act)otp}$), the converter stops operating. The OTP safe-restart protection and the IC restart with switching resuming when the IC temperature drops to below $T_{th(rel)otp}$.

8.5.5 Brownout protection

Brownout protection is designed to limit the lamp power when the input voltage drops close to the output voltage level. The input power has to remain constant. The input current would otherwise increase to a level that is too high for the input circuitry. For the SSL2109T, there is a maximum limit on the on-time of switch $t_{on(high)}$.

The rate of current rise in the coil during the on-phase is proportional to the difference between input voltage and output voltage. Therefore, the peak current cannot be reached before $t_{on(high)}$. As a result the average output current to the LEDs is reduced.

8.5.6 Short-Winding Protection (SWP)

SWP activates if there is a steep rising current through the MOSFET. The voltage across the external resistor connected to the SOURCE pin increases. This current can occur when there is a short from the freewheel diode. Additionally, it occurs due to a small/shorted inductor between the input voltage and the DRAIN pin. If the voltage on the SOURCE pin exceeds 1.5 V, latched protection is triggered following LEB time t_{leb} . In addition, if V_{CC} drops to below $V_{CC(rst)}$, the IC resets the latched protection mode.

8.5.7 Output Short-circuit Protection (OSP)

During the secondary stroke (switch-off time), if a valley is not detected within the off-time limit ($t_{off(high)}$), then typically the output voltage is less than the minimum limit allowed in the application. This condition can occur either during start-up or due to a short-circuit. A timer $t_{det(sc)}$ is started when $t_{off(high)}$ is detected. Timer $t_{det(sc)}$ is reset when a valid valley detection occurs in one of the subsequent cycles or when V_{CC} drops to below $V_{CC(stop)}$.

The timer can also be reset if the maximum limit on the on-time of the switch ($t_{on(high)}$) is reached, which is usually the case at start-up (brownout protection). If no valley is detected and ($t_{on(high)}$) is not reached before $t_{det(sc)}$, then it is concluded that a real short-circuit exists. The IC enters latched protection. If V_{CC} drops to below $V_{CC(rst)}$, the IC resets the latched protection mode (see [Figure 5](#)).

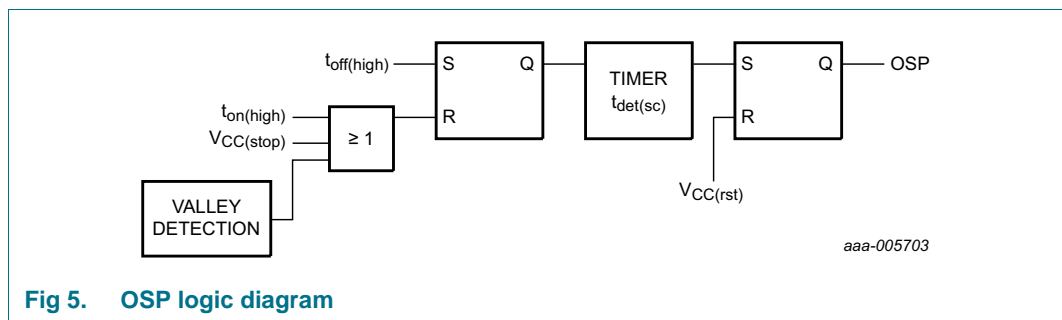

Fig 5. OSP logic diagram

8.6 VCC supply

The SSL2109T can be supplied using three methods:

- Under normal operation, the voltage swing on the DVDT pin is rectified within the IC providing current towards the VCC pin
- At start-up, there is an internal current source connected to the HV pin. The current source provides internal power until either the dV/dt supply or an external current on the VCC pin provides the supply
- Using an auxiliary winding, the voltage is rectified and connected to the VCC pin via a series resistor.

The IC starts up before the voltage at the VCC pin exceeds $V_{CC(\text{startup})}$. The IC locks out (stops switching) when the voltage at the VCC pin is $< V_{CC(\text{stop})}$. The hysteresis between the start and stop levels allows the IC to be supplied by a buffer capacitor until the dV/dt supply is settled. The SSL2109T has an internal V_{CC} clamp, which is an internal active Zener (or shunt regulator). This internal active Zener limits the voltage on the supply VCC pin to the maximum value of V_{CC} . If the maximum current of the dV/dt supply minus the current consumption of the IC (determined by the load on the gate drivers) is lower than the I_{DD} maximum value, no external Zener diode is required in the supply circuit.

8.7 DVDT pin supply

The DVDT pin is connected to an internal single-sided rectification stage. When a different voltage with sufficient amplitude is supplied to the pin, the IC can be powered without any other external power connection. This provides an effective method to prevent additional high power losses, which are the result if a regulator were used for continuously powering the IC. Unlike an auxiliary supply, additional inductor windings are not required.

8.8 VCC regulator

During supply dips, the input voltage can drop so much that it can no longer supply the required IC current through the DVDT pin. Under these conditions, if the VCC voltage drops lower than $V_{CC(\text{swon})\text{reg}}$ level, another regulator with a current capability of up to $I_{HV\text{high}(\text{oper})}$ is started. The job of the regulator is to fill in the required supply current, which the DVDT supply does not deliver, thus preventing that the IC enters UVLO. When the VCC voltage exceeds the $V_{CC(\text{swon})\text{reg}}$ level, the regulator is turned off.

8.9 NTC functionality and PWM regulation

The NTC pin can be used as a control method for LED thermal protection. Alternatively, the pin can be used as an input to disable/enable light output using a digital signal (PWM regulation). The pin has an internal current source that generates the current of $I_{\text{offset}(\text{NTC})}$. An NTC resistor to monitor the LED temperature can be connected directly to the NTC pin. Depending on the resistance value and the corresponding voltage on the NTC pin, the converter reacts as shown in [Figure 6](#).

During start-up, before V_{CC} reaches $V_{CC(\text{startup})}$ the voltage on the NTC pin must be less than the minimum value of $V_{\text{act}(\text{tmr})\text{NTC}}$. This is valid when the voltage on the NTC pin is derived from the V_{CC} using a resistive divider and a PTC in series with the resistor between pins VCC and NTC.

If an NTC resistor is connected between the NTC pin and ground, the voltage on the NTC pin is 0 V when V_{CC} reaches $V_{CC(startup)}$.

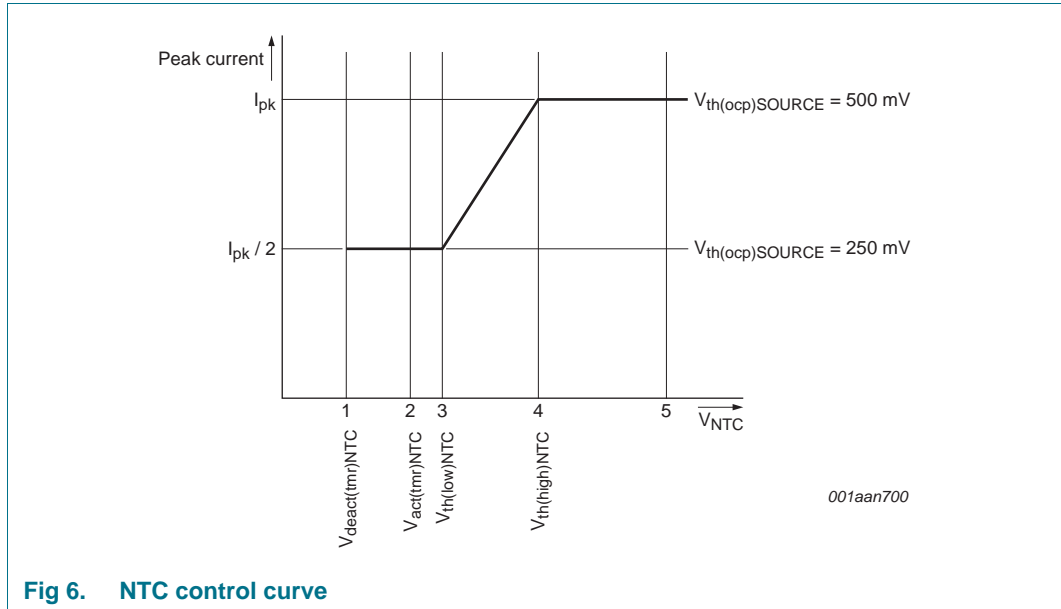

Fig 6. NTC control curve

When the voltage on the NTC pin is higher than $V_{th(high)NTC}$ (see Figure 6 (4)), the converter delivers nominal output current. When the voltage is lower than this level, the peak current is gradually reduced until $V_{th(low)NTC}$ is reached (see Figure 6 (3)). The peak current is now half the peak current of nominal operation. When $V_{act(tmr)NTC}$ is passed (see Figure 6 (2)), a timer starts to run to distinguish between the following situations:

- If the low-level $V_{deact(tmr)NTC}$ is not reached within time $t_{to(deact)NTC}$ (see Figure 6 (1)), LED overtemperature is detected. The IC stops switching and attempts to restart from the HV pin voltage. The converter restarts from an NTC protection shutdown when the voltage on the NTC pin exceeds $V_{th(high)NTC}$ (see Figure 6 (4)). It is assumed that the reduction in peak current does not result in a lower NTC temperature and LED OTP is activated.
- If the low-level $V_{deact(tmr)NTC}$ is reached within the time $t_{to(deact)NTC}$ (see Figure 6 (1)) it is assumed that the pin is pulled down externally. The restart function is not triggered. Instead, the output current is reduced to zero. PWM regulation and consequently LED output current regulation can be implemented this way. The output current rises again when the voltage is higher than $V_{th(low)NTC}$.

8.9.1 Soft-start function

The NTC pin can be used to make a soft start function. During switch-on, the level on the NTC pin is low. By connecting a capacitor (in parallel with the NTC resistor), a time constant can be defined. The time constant causes the level on the NTC pin to increase slowly. When passing level $V_{th(low)NTC}$ (see Figure 6 (3)), the convertor starts with half of the maximum current. The output current slowly increases to maximum when $V_{th(high)NTC}$ (see Figure 6 (4)) is reached.

9. Limiting values

Table 4. Limiting values

In accordance with the Absolute Maximum Rating System (IEC 60134).

Symbol	Parameter	Conditions	Min	Max	Unit
General					
SR	slew rate	on pin DRAIN	-5	+5	V/ns
P _{tot}	total power dissipation	SO8 package	-	0.6	W
T _{amb}	ambient temperature		-40	+125	°C
T _j	junction temperature		-40	+150	°C
T _{stg}	storage temperature		-55	+150	°C
Voltages					
V _{CC}	supply voltage	continuous	[1] -0.4	+20	V
V _{DRAIN}	voltage on pin DRAIN		-0.4	+600	V
V _{HV}	voltage on pin HV	current limited	-0.4	+600	V
V _{SOURCE}	voltage on pin SOURCE	current limited	-0.4	+5.2	V
V _{NTC}	voltage on pin NTC	current limited	-0.4	+5.2	V
Currents					
I _{DD}	supply current	at pin VCC	[2] -	20	mA
I _{DVDT}	current on pin DVDT	duration 20 μs maximum	-	1.3	A
V _{ESD}	electrostatic discharge voltage	human body model; pins DRAIN and HV	[3] -1	+1	kV
		human body model; all other pins	-2	+2	kV
		charged device	[4] -500	+500	V

[1] The current flowing into the VCC pin must not exceed the maximum I_{DD} value

[2] An internal clamp sets the supply voltage.

[3] Human body model: equivalent to discharging a 100 pF capacitor through a 1.5 kΩ series resistor.

[4] Charged device model: equivalent to charging the IC up to 1 kV and the subsequent discharging of each pin down to 0 V over a 1 Ω resistor.

10. Thermal characteristics

Table 5. Thermal characteristics

Symbol	Parameter	Conditions	Typ	Unit
R _{th(j-a)}	thermal resistance from junction to ambient	in free air; PCB: 2 cm × 3 cm; 2-layer; 35 μm Cu per layer	159	K/W
		in free air; PCB: JEDEC 2s2p	89	K/W
Ψ _{j-top}	thermal characterization parameter from junction to top of package	top package temperature measured at the warmest point on top of the case	0.49	K/W

11. Characteristics

Table 6. Characteristics

Values specified at $T_{amb} = 25\text{ °C}$ unless otherwise specified; all voltages are measured with respect to ground; currents are positive when flowing into the IC.

Symbol	Parameter	Conditions	Min	Typ	Max	Unit
f_{conv}	conversion frequency		-	100	-	kHz
High-voltage						
$I_{leak(DRAIN)}$	leakage current on pin DRAIN	$V_{DRAIN} = 600\text{ V}$	-	-	10	μA
$I_{leak(HV)}$	leakage current on pin HV	$V_{HV} = 600\text{ V}$	-	-	30	μA
Supply						
V_{CC}	supply voltage	operating range	11 8	-	16	V
$V_{CC(startup)}$	start-up supply voltage		11	12	13	V
$V_{CC(stop)}$	stop supply voltage		8	9	10	V
$V_{CC(hys)}$	hysteresis of supply voltage	between $V_{CC(startup)}$ and $V_{CC(stop)}$	2	-	4.5	V
$V_{CC(rst)}$	reset supply voltage		4.5	5	5.5	V
$V_{CC(swon)reg}$	regulator switch-on supply voltage	insufficient dV/dt supply	8.75	9.25	9.75	V
$V_{CC(swoff)reg}$	regulator switch-off supply voltage	insufficient dV/dt supply	9.5	10	10.5	V
$V_{CC(reg)hys}$	regulator supply voltage hysteresis	$V_{CC(swoff)reg} - V_{CC(swon)reg}$	0.3	-	-	V
$V_{CC(regswon-stop)}$	supply voltage difference between regulator switch-on and stop	$V_{CC(swon)reg} - V_{CC(stop)}$	0.3	-	-	V
Consumption						
$I_{stb(HV)}$	standby current on pin HV	during start-up or in protection; $V_{HV} = 100\text{ V}$	300	350	400	μA
$I_{CC(INT)}$	internal supply current	normal operation	-	1.3	-	mA
Capability						
$I_{sup(high)HV}$	high supply current on pin HV	Standby: $V_{HV} = 40\text{ V}$; $V_{CC} < V_{CC(stop)}$	1	1.3	1.6	mA
		Regulator On: $V_{HV} = 40\text{ V}$; $V_{CC} < V_{CC(swon)reg}$ after start-up	2	2.3	2.6	mA
Current and SWP protection						
$V_{th(ocp)SOURCE}$	overcurrent protection threshold voltage on pin SOURCE	$\Delta V/\Delta t = 0.1\text{ V}/\mu\text{s}$	480	500	520	mV
		$\Delta V/\Delta t = 0.1\text{ V}/\mu\text{s}$; $V_{NTC} = 0.325\text{ V}$	230	250	270	mV
$t_{d(ocp-swoff)}$	delay time from overcurrent protection to switch-off	$\Delta V/\Delta t = 0.1\text{ V}/\mu\text{s}$	-	75	100	ns
t_{leb}	leading edge blanking time	overcurrent protection	260	300	340	ns
		short-winding protection	210	250	290	ns
Δt_{leb}	leading edge blanking time difference	between t_{leb} for overcurrent protection and short-winding protection	30	50	-	ns
$V_{th(swp)SOURCE}$	short-winding protection threshold voltage on pin SOURCE		1.4	1.5	1.6	V

Table 6. Characteristics ...continued

Values specified at $T_{amb} = 25\text{ °C}$ unless otherwise specified; all voltages are measured with respect to ground; currents are positive when flowing into the IC.

Symbol	Parameter	Conditions	Min	Typ	Max	Unit
Valley detection						
$(\Delta V/\Delta t)_{vrec}$	valley recognition voltage change with time	on pin DRAIN	-30	-20	-10	V/ μ s
f_{ring}	ringing frequency		[2] 200	550	1000	kHz
$\Delta V_{vrec(min)}$	minimum valley recognition voltage difference	voltage drop on pin DRAIN	15	20	25	V
$t_{d(vrec-swon)}$	valley recognition to switch-on delay time		-	100	-	ns
Brownout detection						
$t_{on(high)}$	high on-time		12.5	15	17.5	μ s
Driver (pin DRIVER)						
$I_{source(DRIVER)}$	source current on pin DRIVER	1.5 ms maximum; $V_{DRIVER} = 2\text{ V}$	-	-0.195	-	A
$I_{sink(DRIVER)}$	sink current on pin DRIVER	20 μ s maximum; $V_{DRIVER} = 2\text{ V}$	-	0.28	-	A
		20 μ s maximum; $V_{DRIVER} = 10\text{ V}$	-	0.46	-	A
$V_{o(DRIVER)max}$	maximum output voltage on pin DRIVER	$V_{CC} > V_{CC(startup)}$	9	10.5	12	V
$V_{o(DRIVER)min}$	minimum output voltage on pin DRIVER	$V_{CC} = V_{CC(stop)}$	6.5	7.5	8.5	V
NTC functionality						
$V_{th(high)NTC}$	high threshold voltage on pin NTC		0.47	0.5	0.53	V
$V_{th(low)NTC}$	low threshold voltage on pin NTC		0.325	0.35	0.375	V
$V_{act(tmr)NTC}$	timer activation voltage on pin NTC		0.26	0.3	0.325	V
$V_{deact(tmr)NTC}$	timer deactivation voltage on pin NTC		0.17	0.2	0.23	V
$t_{to(deact)NTC}$	deactivation time-out time on pin NTC		33	46	59	μ s
$I_{offset(NTC)}$	offset current on pin NTC		-	-47	-	μ A
OSP						
$t_{det(sc)}$	short-circuit detection time		16	20	24	ms
$t_{off(high)}$	high off-time		30	36	42	μ s
Temperature protection						
$T_{th(act)otp}$	overtemperature protection activation threshold temperature		160	170	180	$^{\circ}$ C
$T_{th(rel)otp}$	overtemperature protection release threshold temperature		90	100	110	$^{\circ}$ C

[1] An internal clamp sets the supply voltage. The current into the VCC pin must not exceed the maximum I_{DD} value (see [Table 4](#)).

[2] This parameter is not tested during production, by design it is guaranteed

12. Application information

An LED driver with the SSL2109T can be a buck, tapped buck or flyback converter operating in BCM. [Figure 7](#) shows a buck solution in a low ripple configuration using a minimum of components.

Capacitor C3 buffers the IC supply voltage, which is powered via the HV pin at start-up and via C5 during normal operation. Sense resistors R4 and R5 convert the current through MOSFET Q1 into a voltage on pin Source. The value of these resistors determines the maximum primary peak current on MOSFET Q1, and thus the LED current. Resistor R6 reduces the reverse current into the DRIVER pin. The DRAIN pin is connected with the drain of Q1 for valley detection.

In the example shown in [Figure 7](#), the NTC pin is used for temperature protection. Negative Temperature Coefficient (NTC) resistor R3 sets the temperature level. Capacitor C4 reduces noise on the NTC pin. See the SSL2109T *application note* for more information.

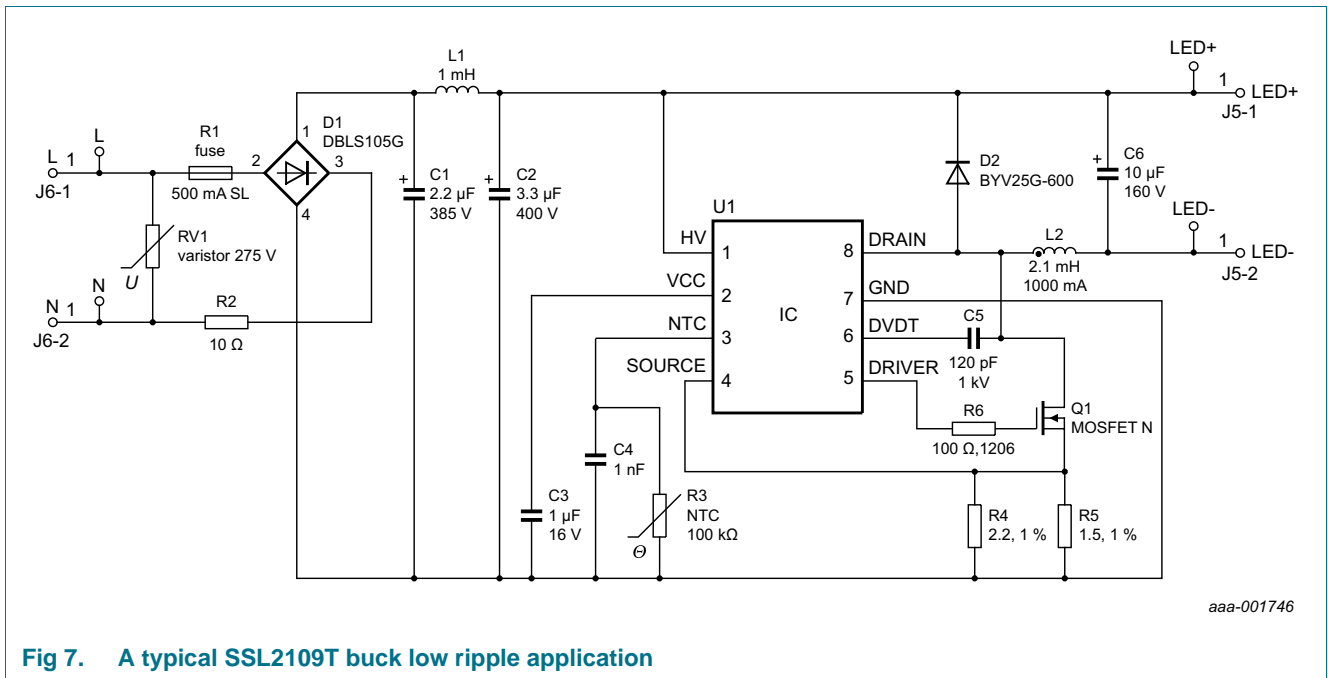

Fig 7. A typical SSL2109T buck low ripple application

13. Package outline

SO8: plastic small outline package; 8 leads; body width 3.9 mm

SOT96-1

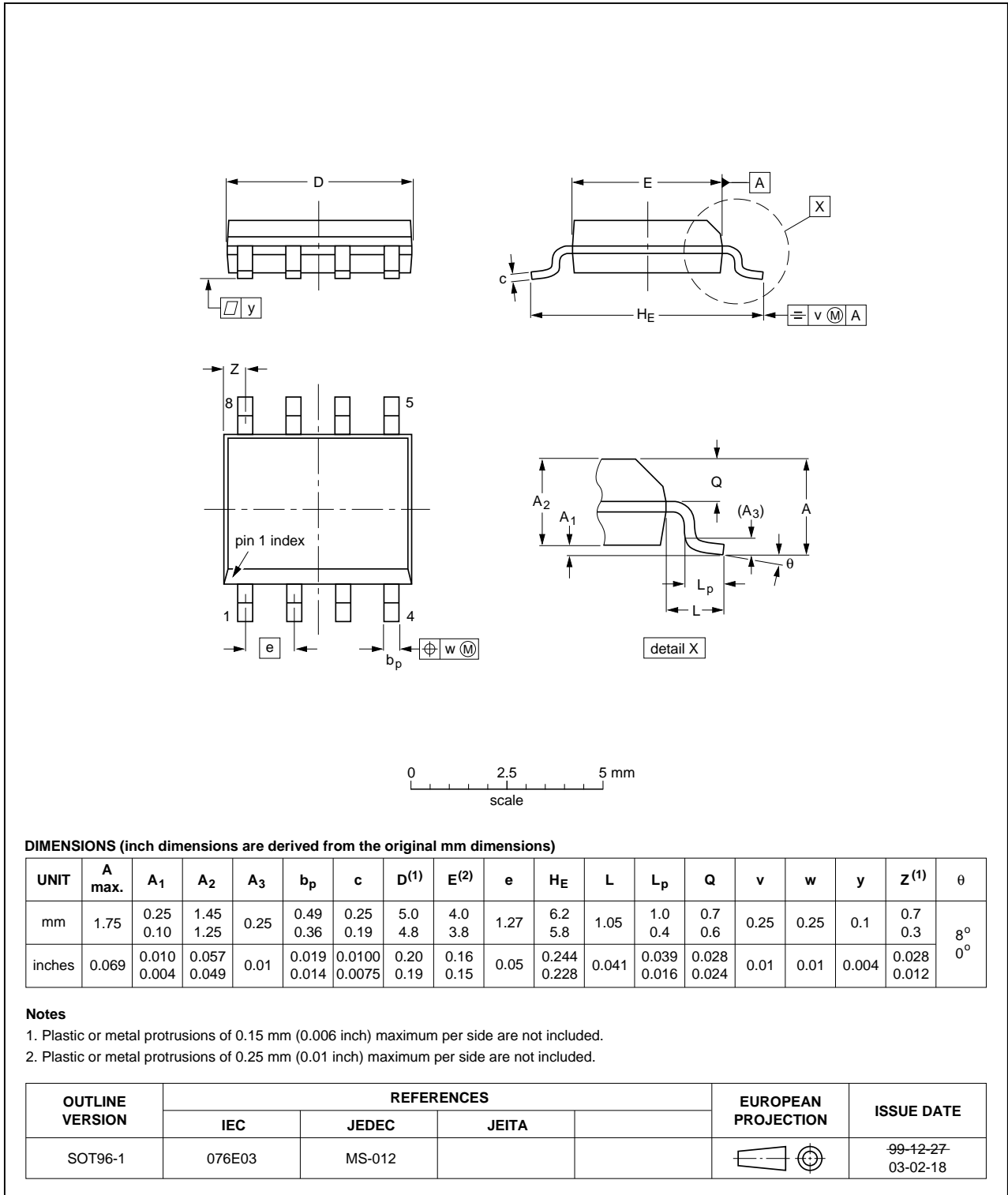

Fig 8. Package outline SOT96-1 (SOT8)

14. Abbreviations

Table 7. Abbreviations

Acronym	Description
BCM	Boundary Conduction Mode
BOM	Bill Of Materials
LEB	Leading-Edge Blanking
LED	Light Emitting Diode
MOSFET	Metal-Oxide Semiconductor Field-Effect Transistor
OCP	OverCurrent Protection
OSP	Output Short Protection
OTP	OverTemperature Protection
PCB	Printed-Circuit Board
PWM	Pulse-Width Modulation
SWP	Short-Winding Protection
UVLO	UnderVoltage LockOut
ZCS	Zero-Current Switching

15. References

- [1] **AN11041** — SSL21081, SSL21083, and SSL2109 non-dimmable buck converter in low ripple configurations
- [2] **AN11263** — 230 V (AC) mains dimmable LED driver using the SSL2129AT or SSL21084AT

16. Revision history

Table 8. Revision history

Document ID	Release date	Data sheet status	Change notice	Supersedes
SSL2109T v.5	20131003	Product data sheet	-	SSL2109_SER v.4
Modifications:	• Text and graphics have been updated throughout the data sheet.			
SSL2109_SER v.4	20121026	Product data sheet	-	SSL2109_SER v.3
SSL2109_SER v.3	20120604	Product data sheet	-	SSL2109T v.2
SSL2109T v.2	20120426	Product data sheet	-	SSL2109 v.1.1
SSL2109 v.1.1	20120410	Preliminary data sheet	-	SSL2109 v.1
SSL2109 v.1	20120330	Preliminary data sheet	-	-

17. Legal information

17.1 Data sheet status

Document status ^{[1][2]}	Product status ^[3]	Definition
Objective [short] data sheet	Development	This document contains data from the objective specification for product development.
Preliminary [short] data sheet	Qualification	This document contains data from the preliminary specification.
Product [short] data sheet	Production	This document contains the product specification.

[1] Please consult the most recently issued document before initiating or completing a design.

[2] The term 'short data sheet' is explained in section "Definitions".

[3] The product status of device(s) described in this document may have changed since this document was published and may differ in case of multiple devices. The latest product status information is available on the Internet at URL <http://www.nxp.com>.

17.2 Definitions

Draft — The document is a draft version only. The content is still under internal review and subject to formal approval, which may result in modifications or additions. NXP Semiconductors does not give any representations or warranties as to the accuracy or completeness of information included herein and shall have no liability for the consequences of use of such information.

Short data sheet — A short data sheet is an extract from a full data sheet with the same product type number(s) and title. A short data sheet is intended for quick reference only and should not be relied upon to contain detailed and full information. For detailed and full information see the relevant full data sheet, which is available on request via the local NXP Semiconductors sales office. In case of any inconsistency or conflict with the short data sheet, the full data sheet shall prevail.

Product specification — The information and data provided in a Product data sheet shall define the specification of the product as agreed between NXP Semiconductors and its customer, unless NXP Semiconductors and customer have explicitly agreed otherwise in writing. In no event however, shall an agreement be valid in which the NXP Semiconductors product is deemed to offer functions and qualities beyond those described in the Product data sheet.

17.3 Disclaimers

Limited warranty and liability — Information in this document is believed to be accurate and reliable. However, NXP Semiconductors does not give any representations or warranties, expressed or implied, as to the accuracy or completeness of such information and shall have no liability for the consequences of use of such information. NXP Semiconductors takes no responsibility for the content in this document if provided by an information source outside of NXP Semiconductors.

In no event shall NXP Semiconductors be liable for any indirect, incidental, punitive, special or consequential damages (including - without limitation - lost profits, lost savings, business interruption, costs related to the removal or replacement of any products or rework charges) whether or not such damages are based on tort (including negligence), warranty, breach of contract or any other legal theory.

Notwithstanding any damages that customer might incur for any reason whatsoever, NXP Semiconductors' aggregate and cumulative liability towards customer for the products described herein shall be limited in accordance with the *Terms and conditions of commercial sale* of NXP Semiconductors.

Right to make changes — NXP Semiconductors reserves the right to make changes to information published in this document, including without limitation specifications and product descriptions, at any time and without notice. This document supersedes and replaces all information supplied prior to the publication hereof.

Suitability for use — NXP Semiconductors products are not designed, authorized or warranted to be suitable for use in life support, life-critical or safety-critical systems or equipment, nor in applications where failure or malfunction of an NXP Semiconductors product can reasonably be expected to result in personal injury, death or severe property or environmental damage. NXP Semiconductors and its suppliers accept no liability for inclusion and/or use of NXP Semiconductors products in such equipment or applications and therefore such inclusion and/or use is at the customer's own risk.

Applications — Applications that are described herein for any of these products are for illustrative purposes only. NXP Semiconductors makes no representation or warranty that such applications will be suitable for the specified use without further testing or modification.

Customers are responsible for the design and operation of their applications and products using NXP Semiconductors products, and NXP Semiconductors accepts no liability for any assistance with applications or customer product design. It is customer's sole responsibility to determine whether the NXP Semiconductors product is suitable and fit for the customer's applications and products planned, as well as for the planned application and use of customer's third party customer(s). Customers should provide appropriate design and operating safeguards to minimize the risks associated with their applications and products.

NXP Semiconductors does not accept any liability related to any default, damage, costs or problem which is based on any weakness or default in the customer's applications or products, or the application or use by customer's third party customer(s). Customer is responsible for doing all necessary testing for the customer's applications and products using NXP Semiconductors products in order to avoid a default of the applications and the products or of the application or use by customer's third party customer(s). NXP does not accept any liability in this respect.

Limiting values — Stress above one or more limiting values (as defined in the Absolute Maximum Ratings System of IEC 60134) will cause permanent damage to the device. Limiting values are stress ratings only and (proper) operation of the device at these or any other conditions above those given in the Recommended operating conditions section (if present) or the Characteristics sections of this document is not warranted. Constant or repeated exposure to limiting values will permanently and irreversibly affect the quality and reliability of the device.

Terms and conditions of commercial sale — NXP Semiconductors products are sold subject to the general terms and conditions of commercial sale, as published at <http://www.nxp.com/profile/terms>, unless otherwise agreed in a valid written individual agreement. In case an individual agreement is concluded only the terms and conditions of the respective agreement shall apply. NXP Semiconductors hereby expressly objects to applying the customer's general terms and conditions with regard to the purchase of NXP Semiconductors products by customer.

No offer to sell or license — Nothing in this document may be interpreted or construed as an offer to sell products that is open for acceptance or the grant, conveyance or implication of any license under any copyrights, patents or other industrial or intellectual property rights.

Export control — This document as well as the item(s) described herein may be subject to export control regulations. Export might require a prior authorization from competent authorities.

Quick reference data — The Quick reference data is an extract of the product data given in the Limiting values and Characteristics sections of this document, and as such is not complete, exhaustive or legally binding.

Non-automotive qualified products — Unless this data sheet expressly states that this specific NXP Semiconductors product is automotive qualified, the product is not suitable for automotive use. It is neither qualified nor tested in accordance with automotive testing or application requirements. NXP Semiconductors accepts no liability for inclusion and/or use of non-automotive qualified products in automotive equipment or applications.

In the event that customer uses the product for design-in and use in automotive applications to automotive specifications and standards, customer (a) shall use the product without NXP Semiconductors' warranty of the product for such automotive applications, use and specifications, and (b)

whenever customer uses the product for automotive applications beyond NXP Semiconductors' specifications such use shall be solely at customer's own risk, and (c) customer fully indemnifies NXP Semiconductors for any liability, damages or failed product claims resulting from customer design and use of the product for automotive applications beyond NXP Semiconductors' standard warranty and NXP Semiconductors' product specifications.

Translations — A non-English (translated) version of a document is for reference only. The English version shall prevail in case of any discrepancy between the translated and English versions.

17.4 Trademarks

Notice: All referenced brands, product names, service names and trademarks are the property of their respective owners.

GreenChip — is a trademark of NXP B.V.

18. Contact information

For more information, please visit: <http://www.nxp.com>

For sales office addresses, please send an email to: salesaddresses@nxp.com

19. Contents

1	General description	1
2	Features and benefits	1
3	Applications	2
4	Quick reference data	2
5	Ordering information	3
6	Block diagram	3
7	Pinning information	4
7.1	Pinning	4
7.2	Pin description	4
8	Functional description	5
8.1	Introduction	5
8.2	Converter operation	5
8.3	Driver pin	5
8.4	Valley detection	6
8.5	Protective features	7
8.5.1	UnderVoltage LockOut (UVLO)	7
8.5.2	Leading-Edge Blanking (LEB)	7
8.5.3	OverCurrent Protection (OCP)	7
8.5.4	OverTemperature Protection (OTP)	7
8.5.5	Brownout protection	8
8.5.6	Short-Winding Protection (SWP)	8
8.5.7	Output Short-circuit Protection (OSP)	8
8.6	VCC supply	9
8.7	DVDT pin supply	9
8.8	VCC regulator	9
8.9	NTC functionality and PWM regulation	9
8.9.1	Soft-start function	10
9	Limiting values	11
10	Thermal characteristics	11
11	Characteristics	12
12	Application information	14
13	Package outline	15
14	Abbreviations	16
15	References	16
16	Revision history	17
17	Legal information	18
17.1	Data sheet status	18
17.2	Definitions	18
17.3	Disclaimers	18
17.4	Trademarks	19
18	Contact information	19
19	Contents	20

Please be aware that important notices concerning this document and the product(s) described herein, have been included in section 'Legal information'.

© NXP B.V. 2013.

All rights reserved.

For more information, please visit: <http://www.nxp.com>

For sales office addresses, please send an email to: salesaddresses@nxp.com

Date of release: 3 October 2013

Document identifier: SSL2109T





Looking for pricing, stock, or lifecycle information?

Click below to explore more details on WIN SOURCE:

 [View SSL2109T/1,118 on WIN SOURCE](#)

 [NXP / Nexperia Information](#)

Optimize Your Supply Chain with WIN SOURCE Solutions

-  Global Sourcing Solution
-  Obsolete Management
-  Cost Control Management
-  Shortage Management
-  Alternative Solution
-  Excess Inventory Management