



**THE DATASHEET OF
PI5USB31213AXEAEX**



PI5USB31213A

Type-C™ Dual Role Port Controller with USB3.1 Gen2 10Gbps Mux

Description

The PI5USB31213A is a 10Gbps dual differential channel bi-directional multiplexer/de-multiplexer switch solution for USB 3.1 Gen2 Type-C connector applications. PI5USB31213A switches between the USB controller and the new Type-C connector. It supports host mode, device mode and dual-role mode ports with automatic configuration based on the voltage levels detected on CC pin. It offers excellent signal integrity for high-speed signals at low power dissipation.

PI5USB31213A supports both pin and I2C control base on ADDR pin setting. In pin control mode, the PORT input pin determines the port setting, whether this is a host, device or dual-role port. In host mode, the system can monitor ID pin to know the connector status while default current mode is set. Systems running in device mode can monitor system VBUS for connector status as well as OUT1 and OUT2 pins for host's charging profile capability.

Enabling I2C control mode allow high flexibility for port control and communications through registers read/write in PI5USB31213A. There is also flexibility to support Default, 1.5A and 3A current modes. An interrupt signal for indicating changes with the I2C registers is sent to the master to notify the system any change in the Type-C connector while in parallel the system can still monitor ID pin.

Applications

- Notebooks
- Mobile Phones
- Tablets
- Docking Station
- Industrial PC
- IP Cameras
- LTE Router
- External Storage

Ordering Information

Part Number	Package	Description
PI5USB31213AXEAEX	XEA	24-contact, Extra Thin Fine Pitch QFN (X1QFN)

Notes:

1. EU Directive 2002/95/EC (RoHS), 2011/65/EU (RoHS 2) & 2015/863/EU (RoHS 3) compliant. All applicable RoHS exemptions applied.
2. See <http://www.diodes.com/quality/lead-free/> for more information about Diodes Incorporated's definitions of Halogen- and Antimony-free, "Green" and Lead-free. Thermal characteristics can be found on the company web site at www.diodes.com/design/support/packaging/
3. E = Pb-free and Green
4. X suffix = Tape/Reel

Features

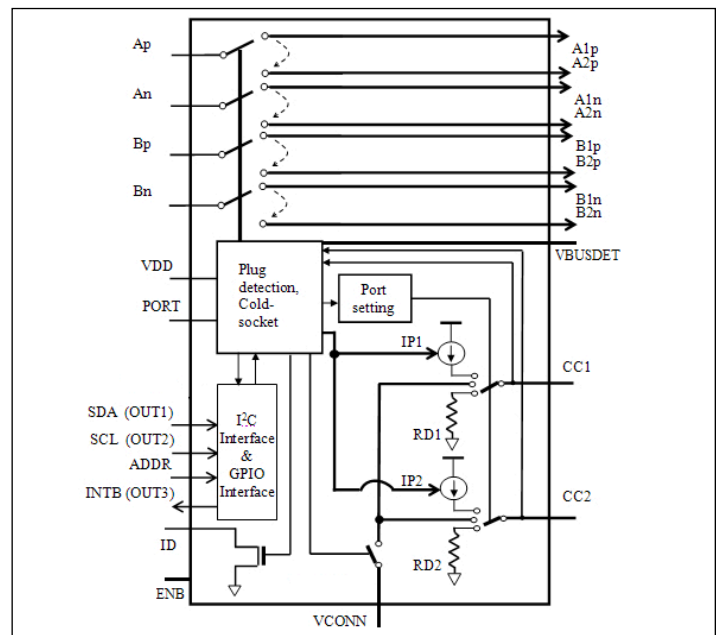

- Compatible to USB Type-C™ Specification
- Dual Differential Channel, 10Gbps 2:1 USB 3.1 Gen 2 Mux/DeMux
- Switches USB controller and Type-C connector
- Supports Host-mode/Device-mode/Dual-role mode
- Auto-configure ports orientation through CC detection
- Supports VBUS powered Device (UFP) applications
- Supports VCONN to power active cables and other accessories
- Supports over-current protection and over-voltage protection for VCONN
- Audio and Debug Accessory Support
- Supports for Try.SRC and Try.SNK DRP Modes
- Allow both pin control and I2C interface
- Integrated power switches, high-precision resistors and current sources for CC pins
- Provides support for default current, 1.5A and 3A modes with I2C control
- Output indicator for plug-in detection
- Power saving mode
- Wide power supply range : 2.7V – 5.5V
- Temperature Range: -40oC to 85oC
- Packaging (Pb-free & Green):
 - 24- contact, TQFN(2mm x 4mm)

Block Diagram



Looking for pricing, stock, or lifecycle information?

Click below to explore more details on WIN SOURCE:

-  [View PI5USB31213AXEAEX on WIN SOURCE](#)
-  [Diodes Incorporated Information](#)

Optimize Your Supply Chain with WIN SOURCE Solutions

-  Global Sourcing Solution
-  Obsolete Management
-  Cost Control Management
-  Shortage Management
-  Alternative Solution
-  Excess Inventory Management