



# THE DATASHEET OF RPS-65-15





**Features**

- 3"x2" compact size
- Medical safety approved (2 x MOPP) according to ANSI/AAMI ES60601-1 and IEC/BS EN/EN60601-1
- Suitable for BF application with appropriate system consideration
- Cooling by free air convection
- EMI class B for class II configuration
- No load power consumption < 0.1W
- Extremely low leakage current
- Protections: Short circuit / Overload / Over voltage
- Operating altitude up to 4000 meters
- 3 years warranty

**Applications**

- Oral irrigator
- Hemodialysis machine
- Medical computer monitors
- Sleep apnea devices

**GTIN CODE**

MW Search: <https://www.meanwell.com/serviceGTIN.aspx>

**Description**

RPS-65 is a 65W highly reliable green PCB type medical power supply with a high power density on the 3" by 2" footprint. It accepts 80~264VAC input and offers various output voltages between 3.3V and 48V. The working efficiency is up to 91% and the extremely low no load power consumption is down below 0.1W. RPS-65 is able to be used for Class II (no FG) system design. The extremely low leakage current is less than 100 μA. In addition, it conforms to international medical regulations (2\*MOPP) and EMC BS EN/EN55011, perfectly fitting all kinds of BF rated "patient contact" medical system equipment.

**Model Encoding**

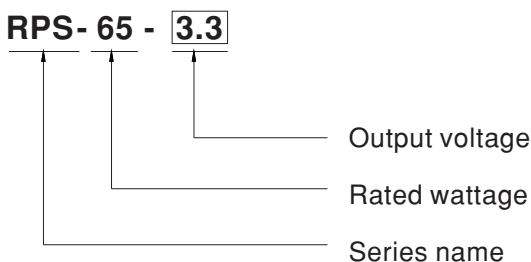

SPECIFICATION

ORDER NO.	RPS-65-3.3	RPS-65-5	RPS-65-7.5	RPS-65-12	RPS-65-15	RPS-65-24	RPS-65-48		
OUTPUT	DC VOLTAGE	3.3V	5V	7.5V	12V	15V	24V	48V	
	RATED CURRENT	10A	10A	8A	5.42A	4.34A	2.71A	1.36A	
	CURRENT RANGE	0 ~ 11A	0 ~ 11A	0 ~ 8.8A	0 ~ 5.96A	0 ~ 4.77A	0 ~ 2.98A	0 ~ 1.49A	
	RATED POWER	33W	50W	60W	65W	65.1W	65W	65.3W	
	PEAK LOAD(10sec.)	36.3W	55W	66W	71.5W	71.6W	71.5W	71.5W	
	RIPPLE & NOISE (max.) Note.2	80mVp-p	80mVp-p	80mVp-p	120mVp-p	120mVp-p	120mVp-p	150mVp-p	
	VOLTAGE ADJ. RANGE	2.9~3.6V	4.7~5.5V	7.12~8.3V	11.4~13.2V	13.5~16.5V	22.8~27.6V	45.6~52.8V	
	VOLTAGE TOLERANCE Note.3	±2.0%	±2.0%	±2.0%	±2.0%	±1.0%	±1.0%	±1.0%	
	LINE REGULATION	±0.5%	±0.5%	±0.5%	±0.5%	±0.5%	±0.5%	±0.5%	
	LOAD REGULATION	±2.0%	±2.0%	±2.0%	±2.0%	±1.0%	±1.0%	±1.0%	
SETUP, RISE TIME	500ms, 30ms / 230VAC    500ms, 30ms / 115VAC at full load								
HOLD UP TIME (Typ.)	30ms / 230VAC    12ms / 115VAC at full load								
INPUT	VOLTAGE RANGE Note.4	80 ~ 264VAC							
	FREQUENCY RANGE	47 ~ 63Hz							
	EFFICIENCY (Typ.)	80%	84%	85%	88%	89%	90%	91%	
	AC CURRENT (Typ.)	1.5A / 115VAC		1A / 230VAC					
	INRUSH CURRENT (Typ.)	COLD STAR 30A/115VAC 50A/230VAC							
LEAKAGE CURRENT(max.) Note.5	Touch current < 100µA/264VAC								
PROTECTION	OVERLOAD	115 ~ 150% rated output power Protection type : Hiccup mode, recovers automatically after fault condition is removed							
	OVER VOLTAGE	3.8~4.5V	5.7~6.8V	8.6~11.3V	13.8~16.2V	17.2~20.3V	27.6~32.4V	55.2~64.8V	
ENVIRONMENT	WORKING TEMP.	-30 ~ +70°C (Refer to "Derating Curve")							
	WORKING HUMIDITY	20% ~ 90% RH non-condensing							
	STORAGE TEMP., HUMIDITY	-40 ~ +85°C, 10 ~ 95% RH non-condensing							
	TEMP. COEFFICIENT	±0.03% / °C (0 ~ 50°C)							
	VIBRATION	10 ~ 500Hz, 2G 10min./1cycle, period for 60min. each along X, Y, Z axes							
	OPERATING ALTITUDE Note.6	4000 meters							
SAFETY & EMC (Note. 7)	SAFETY STANDARDS	IEC 60601-1:2005+A1+A2, TUV BS EN/ EN 60601-1:2006+A1+A12+A2, ANSI/AAMI ES60601-1:2005+A2 CAN/CSA C22.2 No. 60601-1:2014+A2, EAC TP TC 004 approved; Design refer to BS EN/EN60335-1 (by request)							
	ISOLATION LEVEL	Primary-Secondary: 2xMOPP							
	WITHSTAND VOLTAGE	I/P-O/P: 4KVAC							
	ISOLATION RESISTANCE	I/P-O/P:100M Ohms / 500VDC / 25°C / 70% RH							
	EMC EMISSION	Parameter	Standard				Test Level / Note		
		Conducted emission	BS EN/EN55011 (CISPR11)				Class B		
		Radiated emission	BS EN/EN55011 (CISPR11)				Class B		
		Harmonic current	BS EN/EN61000-3-2				Class A		
	Voltage flicker	BS EN/EN61000-3-3				----			
	EMC IMMUNITY	BS EN/EN55035, BS EN/EN60601-1-2							
		Parameter	Standard				Test Level / Note		
		ESD	BS EN/EN61000-4-2				Level 4, 15KV air ; Level 4, 8KV contact		
		RF field susceptibility	BS EN/EN61000-4-3				Level 3, 10V/m( 80MHz~2.7GHz ) Table 9, 9~28V/m( 385MHz~5.78GHz )		
EFT bursts		BS EN/EN61000-4-4				Level 3, 2KV			
Surge susceptibility		BS EN/EN61000-4-5				Level 4, 2KV/Line-Line			
Conducted susceptibility		BS EN/EN61000-4-6				Level 3, 10V			
Magnetic field immunity		BS EN/EN61000-4-8				Level 4, 30A/m			
Voltage dip, interruption	BS EN/EN61000-4-11				100% dip 1 periods, 30% dip 25 periods, 100% interruptions 250 periods				
OTHERS	MTBF	3334.3K hrs min.    Telcordia SR-332 (Bellcore) ; 959.1K hrs min.    MIL-HDBK-217F (25°C)							
	DIMENSION (L*W*H)	76.2*50.8*24mm or 3" * 2" *0.945" inch							
	PACKING	0.11Kg; 120pcs/14.2Kg/0.94CUFT							
NOTE	<p>1. All parameters NOT specially mentioned are measured at 230VAC input, rated load and 25°C of ambient temperature.</p> <p>2. Ripple &amp; noise are measured at 20MHz of bandwidth by using a 12" twisted pair-wire terminated with a 0.1 µF &amp; 47 µF parallel capacitor.</p> <p>3. Tolerance : includes set up tolerance, line regulation and load regulation.</p> <p>4. Derating may be needed under low input voltages. Please check the derating curve for more details.</p> <p>5. Touch current was measured from primary input to DC output.</p> <p>6. The ambient temperature derating of 3.5°C/1000m with fanless models and of 5°C/1000m with fan models for operating altitude higher than 2000m(6500ft).</p> <p>7. The power supply is considered a component which will be installed into a final equipment. The final equipment must be re-confirmed that it still meets EMC directives. For guidance on how to perform these EMC tests, please refer to "EMI testing of component power supplies." (as available on <a href="https://www.meanwell.com/Upload/PDF/EMI_statement_en.pdf">https://www.meanwell.com/Upload/PDF/EMI_statement_en.pdf</a>)</p> <p>※ Product Liability Disclaimer : For detailed information, please refer to <a href="https://www.meanwell.com/serviceDisclaimer.aspx">https://www.meanwell.com/serviceDisclaimer.aspx</a></p>								

■ Block Diagram

fosc : 65KHz

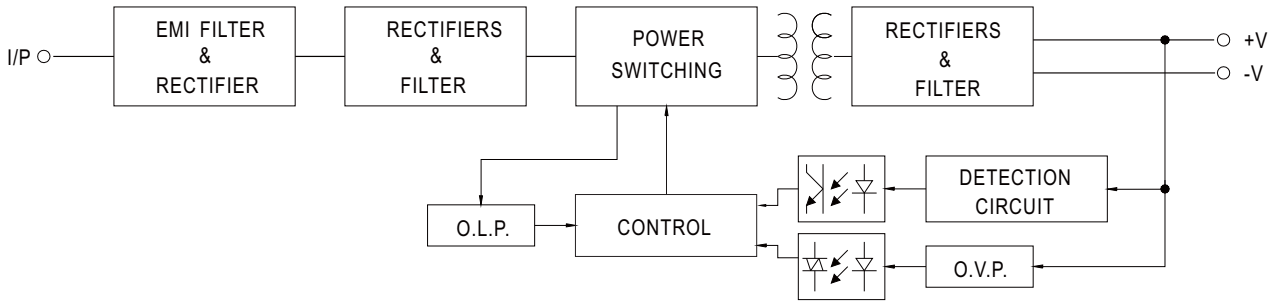

■ Derating Curve

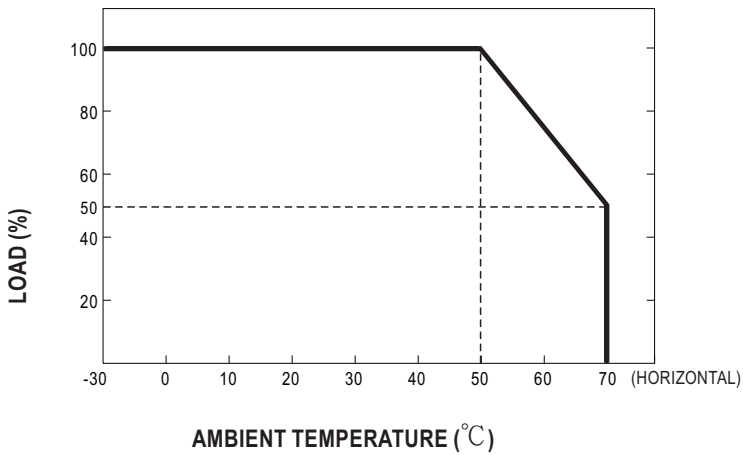

■ Static Characteristics

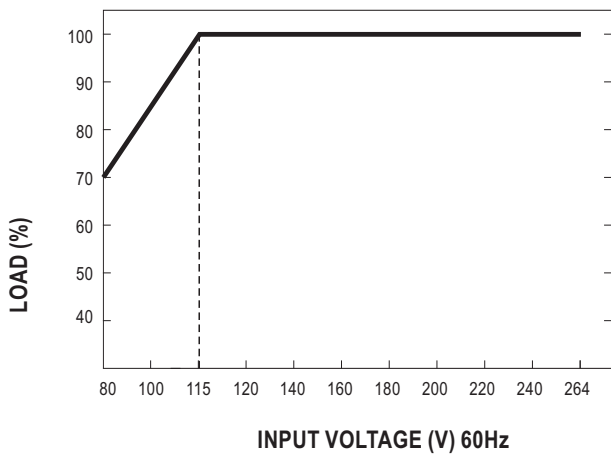

■ Mechanical Specification

Case No. Unit:mm

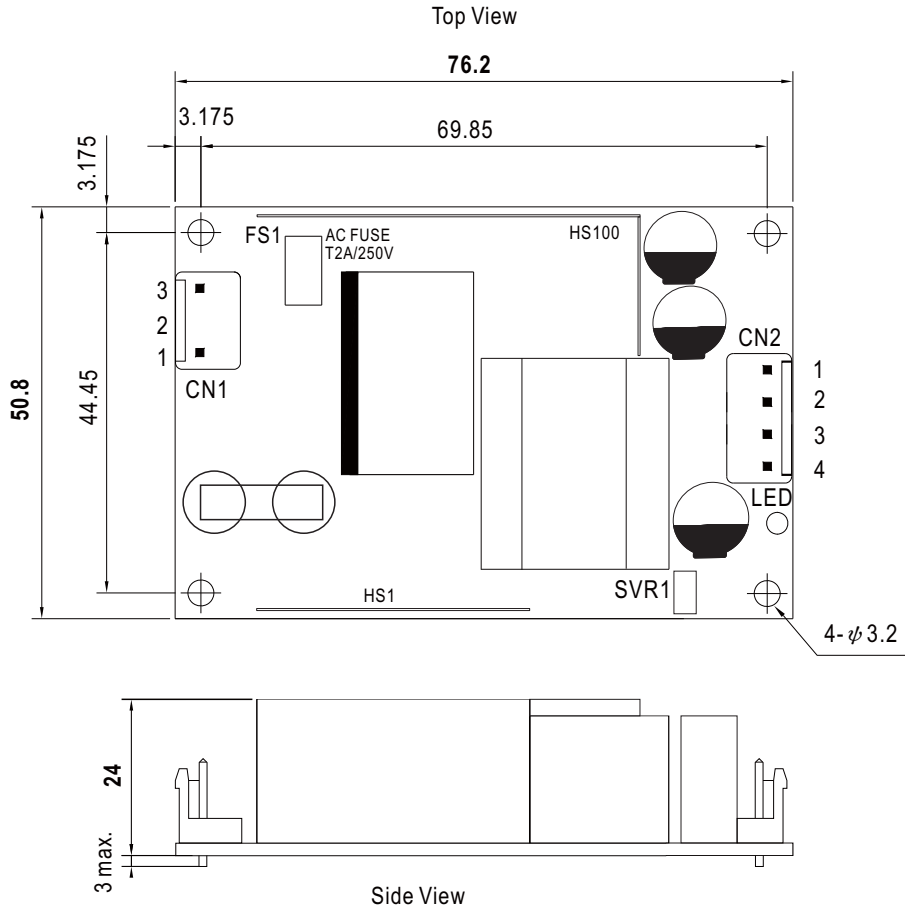

AC Input Connector (CN1) : JST B3P-VH or equivalent

Pin No.	Assignment	Mating Housing	Terminal
1	AC/N	JST VHR or equivalent	JST SVH-21T-P1.1 or equivalent
2	No Pin		
3	AC/L		

DC Output Connector (CN2) : JST B4P-VH or equivalent

Pin No.	Assignment	Mating Housing	Terminal
1	+V	JST VHR or equivalent	JST SVH-21T-P1.1 or equivalent
2	+V		
3	-V		
4	-V		

■ Installation Manual

Please refer to : <http://www.meanwell.com/manual.html>

## Looking for pricing, stock, or lifecycle information?

Click below to explore more details on WIN SOURCE:

- [View RPS-65-15 on WIN SOURCE](#)
- [Mean Well Enterprises Co., Ltd. Information](#)

## Optimize Your Supply Chain with WIN SOURCE Solutions

- ✓ Global Sourcing Solution
- ✓ Obsolete Management
- ✓ Cost Control Management
- ✓ Shortage Management
- ✓ Alternative Solution
- ✓ Excess Inventory Management