



**THE DATASHEET OF  
CM2030-A0TR**



# CM2030

## HDMI Transmitter Port Protection and Interface Device

### Product Description

The CM2030 HDMI Transmitter Port Protection and Interface Device is specifically designed for next generation HDMI Host interface protection.

An integrated package provides all ESD, level shifting/isolation, overcurrent output protection and backdrive protection for an HDMI port in a single 38-pin TSSOP package.

The CM2030 also incorporates a silicon overcurrent protection device for +5 V supply voltage output to the connector.

CM2030 is ideal for applications which do not require HDMI certification but can benefit from level shifters and backdrive protection.

### Features

- Supports Thin Dielectric and 2-layer Boards
- Minimizes TMDS Skew with 0.05 pF Matching
- Long HDMI Cable Support with Integrated I<sup>2</sup>C Accelerator
- Supports Direct Connection to CEC Microcontroller
- Integrated I<sup>2</sup>C Level Shifting to CMOS Level Including Low Logic Level Voltages
- Integrated 8 kV ESD Protection and Backdrive Protection on All External I/O Lines
- Multiport I<sup>2</sup>C Support Eliminates Need for Analog Mux on DDC Lines
- Simplified Layout with Matched 0.5 mm Trace Spacing
- These Devices are Pb-Free and are RoHS Compliant

### Applications

- PC and Consumer Electronics
- Set Top Box, DVD RW, PC, Graphics Cards



**ON Semiconductor®**

<http://onsemi.com>

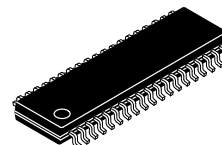

TSSOP 38  
TR SUFFIX  
CASE 948AG

### MARKING DIAGRAM

CM2030-A0TR

CM2030-A0TR = Specific Device Code

### ORDERING INFORMATION

Device	Package	Shipping <sup>†</sup>
CM2030-A0TR	TSSOP-38 (Pb-Free)	2500/Tape & Reel

<sup>†</sup>For information on tape and reel specifications, including part orientation and tape sizes, please refer to our Tape and Reel Packaging Specification Brochure, BRD8011/D.



# CM2030

**Table 1. PIN DESCRIPTIONS**

Pins	Name	ESD Level	Description
4, 35	TMDS_D2+	8 kV (Note 3)	TMDS 0.9 pF ESD Protection (Note 1)
6, 33	TMDS_D2-	8 kV (Note 3)	TMDS 0.9 pF ESD Protection (Note 1)
7, 32	TMDS_D1+	8 kV (Note 3)	TMDS 0.9 pF ESD Protection (Note 1)
9, 30	TMDS_D1-	8 kV (Note 3)	TMDS 0.9 pF ESD Protection (Note 1)
10, 29	TMDS_D0+	8 kV (Note 3)	TMDS 0.9 pF ESD Protection (Note 1)
12, 27	TMDS_D0-	8 kV (Note 3)	TMDS 0.9 pF ESD Protection (Note 1)
13, 26	TMDS_CK+	8 kV (Note 3)	TMDS 0.9 pF ESD Protection (Note 1)
15, 24	TMDS_CK-	8 kV (Note 3)	TMDS 0.9 pF ESD Protection (Note 1)
16	CE_REMOTE_IN	2 kV (Note 4)	CE_SUPPLY Referenced Logic Level In
23	CE_REMOTE_OUT	8 kV (Note 3)	5V_SUPPLY Referenced Logic Level Out plus 10 pF ESD (Note 6)
17	DDC_CLK_IN	2 kV (Note 4)	LV_SUPPLY Referenced Logic Level In
22	DDC_CLK_OUT	8 kV (Note 3)	5V_SUPPLY Referenced Logic Level Out plus 10 pF ESD (Note 6)
18	DDC_DAT_IN	2 kV (Note 4)	LV_SUPPLY Referenced Logic Level In
21	DDC_DAT_OUT	8 kV (Note 3)	5V_SUPPLY Referenced Logic Level Out plus 10 pF ESD (Note 6)
19	HOTPLUG_DET_IN	2 kV (Note 4)	LV_SUPPLY Referenced Logic Level In
20	HOTPLUG_DET_OUT	8 kV (Note 3)	5V_SUPPLY Referenced Logic Level Out plus 10 pF ESD. A 0.1 $\mu$ F Bypass Ceramic Capacitor is Recommended on this Pin (Note 2).
2	LV_SUPPLY	2 kV (Note 4)	Bias for CE / DDC / HOTPLUG Level Shifters
37	CE_SUPPLY	2 kV (Notes 2 & 4)	CEC Bias Voltage. Previously CM2020 ESD_BYN Pin.
1	5V_SUPPLY	2 kV (Note 4)	Current Source for 5V_OUT, VREF for DDC I <sup>2</sup> C Voltage References, and Bias for 8 kV ESD Pins.
38	5V_OUT	8 kV (Note 3)	55 mA Minimum Overcurrent Protected 5 V Output. This Output Must be Bypassed with a 0.1 $\mu$ F Ceramic Capacitor.
3, 5, 8, 11, 14, 25, 28, 31, 34, 36	GND / TMDS_GND	N/A	GND Reference

1. These 2 pins need to be connected together in-line on the PCB. See recommended layout diagram.
2. This output can be connected to an external 0.1  $\mu$ F ceramic capacitor/pads to maintain backward compatibility with the CM2020.
3. Standard IEC 61000-4-2, C<sub>DISCHARGE</sub> = 150 pF, R<sub>DISCHARGE</sub> = 330  $\Omega$ , 5V\_SUPPLY and LV\_SUPPLY within recommended operating conditions, GND = 0 V, 5V\_OUT (pin 38), and HOTPLUG\_DET\_OUT (pin 20) each bypassed with a 0.1  $\mu$ F ceramic capacitor connected to GND.
4. Human Body Model per MIL-STD-883, Method 3015, C<sub>DISCHARGE</sub> = 100 pF, R<sub>DISCHARGE</sub> = 1.5 k $\Omega$ , 5V\_SUPPLY and LV\_SUPPLY within recommended operating conditions, GND = 0 V, 5V\_OUT (pin 38), and HOTPLUG\_DET\_OUT (pin 20) each bypassed with a 0.1  $\mu$ F ceramic capacitor connected to GND.
5. These pins should be routed directly to the associated GND pins on the HDMI connector with single point ground vias at the connector.
6. The slew-rate control and active acceleration circuitry dynamically offsets the system capacitive load on these pins.

**BACKDRIVE PROTECTION AND ISOLATION**

Backdrive current is defined as the undesirable current flow through an I/O pin when that I/O pin’s voltage exceeds the related local supply voltage for that circuitry. This is a potentially common occurrence in multimedia entertainment systems with multiple components and several power plane domains in each system.

For example, if a DVD player is switched off and an HDMI connected TV is powered on, there is a possibility of reverse current flow back into the main power supply rail of the DVD player from pull-ups in the TV. As little as a few milliamps of backdrive current flowing back into the power rail can charge the DVD player’s bulk bypass capacitance on the power rail to some intermediate level. If this level rises above the power-on-reset (POR) voltage level of some of the integrated circuits in the DVD player, then these devices

may not reset properly when the DVD player is turned back on.

If any SOC devices are incorporated in the design which have built-in level shifter and/or ESD protection structures, there can be a risk of permanent damage due to backdrive. In this case, backdrive current can forward bias the on-chip ESD protection structure. If the current flow is high enough, even as little as a few milliamps, it could destroy one of the SOC chip’s internal DRC diodes, as they are not designed for passing DC.

To avoid either of these situations, the CM2030 was designed to block backdrive current, guaranteeing less than 5  $\mu$ A into any I/O pin when the I/O pin voltage exceeds its related operating CM2030 supply voltage.

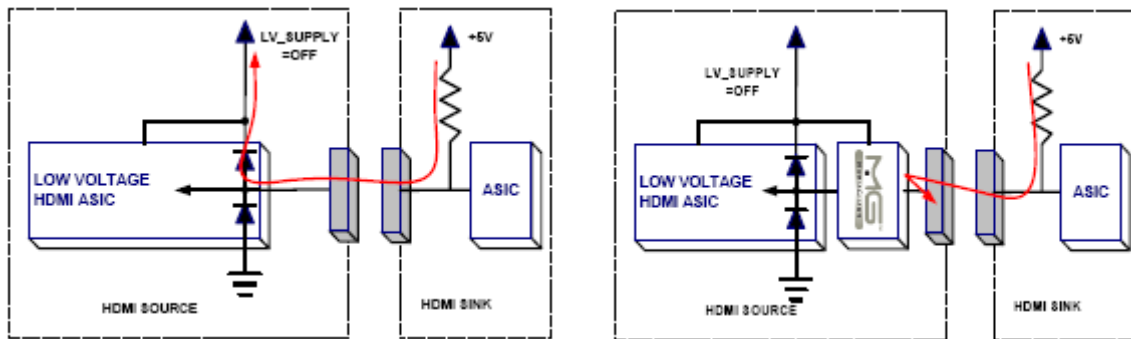

**Figure 1. Backdrive Protection Diagram.**

**DISPLAY DATA CHANNEL (DDC) LINES**

The DDC interface is based on the I<sup>2</sup>C serial bus protocol for EDID configuration.

**Dynamic Pullups**

Based on the HDMI specification, the maximum capacitance of the DDC line can approach 800 pF (50 pF from source, 50 pF from sink, and 700 pF from cable). At the upper range of capacitance values (i.e. long cables), it becomes impossible for the DDC lines to meet the I<sup>2</sup>C timing specifications with the minimum pull-up resistor of 1.5 k $\Omega$ .

For this reason, the CM2030 was designed with an internal I<sup>2</sup>C accelerator to meet the AC timing specification even with very long and non-compliant cables.

The internal accelerator increases the positive slew rate of the DDC\_CLK\_OUT and DDC\_DAT\_OUT lines whenever the sensed voltage level exceeds 0.3\*5V\_SUPPLY (approximately 1.5 V). This provides faster overall risetime in heavily loaded situations without overloading the multi-drop open drain I<sup>2</sup>C outputs elsewhere.

Figure 2 demonstrates the “worst case” operation of the dynamic CM2030 DDC level shifting circuitry (bottom)

against a discrete NFET common-gate level shifter circuit with a typical 1.5 kW pullup at the source (top.) Both are shown driving an off-spec, but unfortunately readily available 31 m HDMI cable which exceeds the 700 pF HDMI specification. Some widely available HDMI cables have been measured at *over 4 nF*.

When the standard I/OD cell releases the NFET discrete shifter, the risetime is limited by the pullup and the parasitics of the cable, source and sink. For long cables, this can extend the risetime and reduce the margin for reading a valid “high” level on the data line. In this case, an HDMI source may not be able to read uncorrupted data and will not be able to initiate a link.

With the CM2030’s dynamic pullups, when the ASIC driver releases its DDC line and the “OUT” line reaches at least 0.3\*VDD (of 5V\_SUPPLY), then the “OUT” active pullups are enabled and the CM2030 takes over driving the cable until the “OUT” voltage approaches the 5V\_SUPPLY rail.

The internal pass element and the dynamic pullups also work together to damp reflections on the longer cables and keep them from glitching the local ASIC.

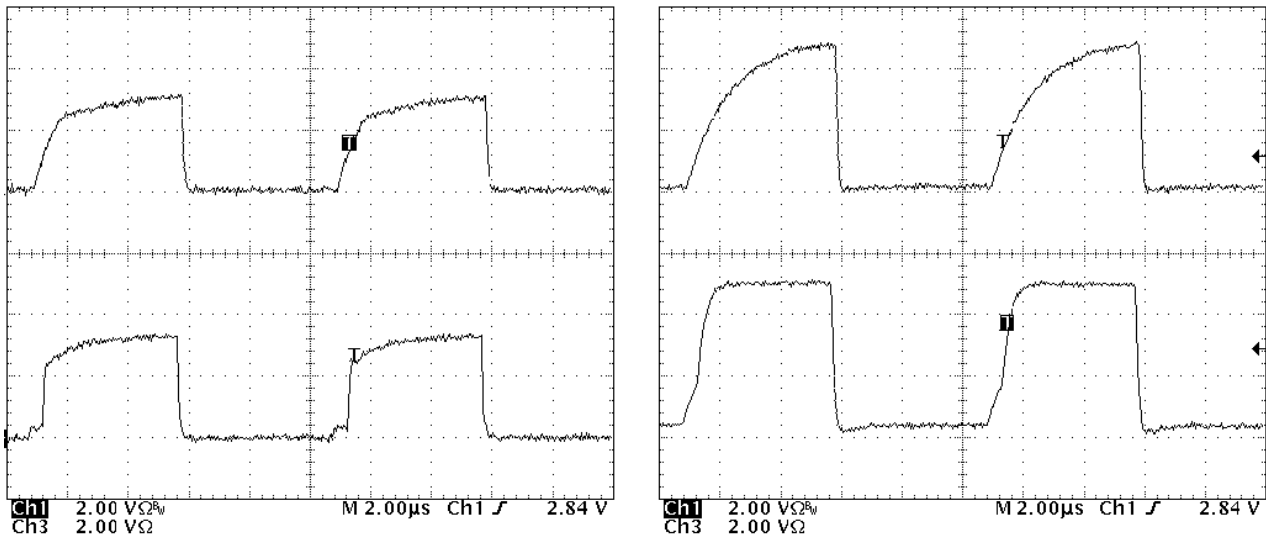

**Figure 2. Dynamic DDC Pullups**  
 (Discrete – Top, CM2030 – Bottom; 3.3 V ASIC – Left, 5 V Cable – Right)

**I<sup>2</sup>C Low Level Shifting**

In addition to the Dynamic Pullups described in the previous section, the CM2030 also incorporates improved I<sup>2</sup>C low-level shifting on the DDC\_CLK\_IN and DDC\_DAT\_IN lines for enhanced compatibility.

Typical discrete NFET level shifters can advertise specifications for low R<sub>DS[on]</sub>, but usually state relatively high V<sub>[GS]</sub> test parameters, requiring a ‘switch’ signal (gate voltage) as high as 10 V or more. At a sink current of 4 mA for the ASIC on DDC\_XX\_IN, the CM2030 guarantees no more than 140 mV increase to DDC\_XX\_OUT, even with a switching control of 2.5 V on LV\_SUPPLY.

When I<sup>2</sup>C devices are driving the external cable, an internal pulldown on DDC\_XX\_IN guarantees that the VOL seen by the ASIC on DDC\_XX\_IN is equal to or lower than DDC\_XX\_OUT.

**Multiport DDC Multiplexing**

By switching LV\_SUPPLY, the DDC/HPD blocks can be independently disabled by engaging their inherent “backdrive” protection. This allows N:1 multiplexing of the low-speed HDMI signals without any additional FET switches.

**CONSUMER ELECTRONICS CONTROL (CEC)**

The Consumer Electronics Control (CEC) line is a high level command and control protocol, based on a single wire multidrop open drain communication bus running at approximately 1 kHz (See Figure 3). While the HDMI link provides only a single point-to-point connection, up to ten (10) CEC devices may reside on the bus, and they may be daisy chained out through other physical connectors including other HDMI ports or other dedicated CEC links. The high level protocol of CEC can be implemented in a simple microcontroller or other interface with any I/OD (input/open-drain) GPIO.

To limit possible EMI and ringing in this potentially complex connection topology, the rise- and fall-time of this line are limited by the specification. However, meeting the slew-rate limiting requirements with additional discrete circuitry in this bi-directional block is not trivial without an additional RX/TX control line to limit the output slew-rate without affecting the input sensing (See Figure 4).

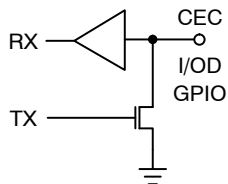

**Figure 3. Typical µC I/OD Driver**

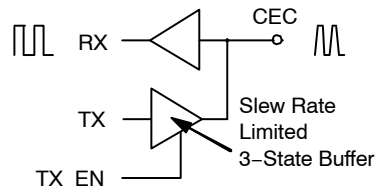

**Figure 4. Three-Pin External Buffer Control**

Simple CMOS buffers cannot be used in this application since the load can vary so much (total pullup of 27 kW to less

than 2 kW, and up to 7.3 nF total capacitance.) The CM2030 targets an output drive slew-rate of less than 100 mV/ms regardless of static load for the CEC line. Additionally, the same internal circuitry will perform active termination, thus reducing ringing and overshoot in entertainment systems connected to legacy or poorly designed CEC nodes.

The CM2030’s bi-directional slew rate limiting is integrated into the CEC level-shifter functionality thus allowing the designer to directly interface a simple low voltage CMOS GPIO directly to the CEC bus and simultaneously guarantee meeting all CEC output logic levels and HDMI slew-rate and isolation specifications (See Figure 5).

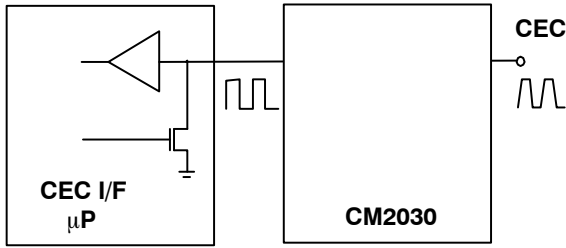

Figure 5. Integrated CM2030 Solution

The CM2030 also includes an internal backdrive protected static pullup 120 μA current source from the CE\_SUPPLY rail in addition to the dynamic slew rate control circuitry.

Figure 6 shows a typical shaped CM2030 CEC output (bottom) against a ringing uncontrolled discrete solution (top).

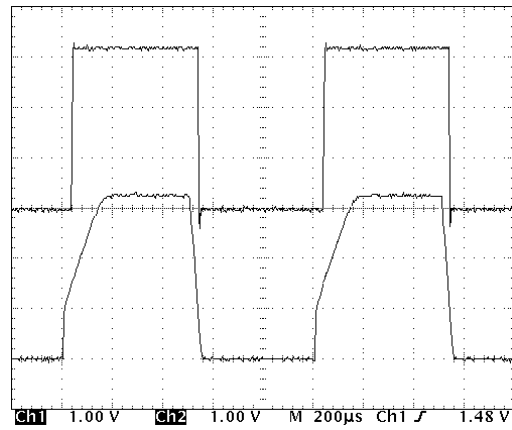

Figure 6. CM2030 CEC Output

HDMI certification requires capacitance measurement of the CEC line to be less than 150 pF per device. Due to the active circuit inside the CM2030 CEC line, CM2030 may cause false readings during the CEC capacitance measurement and not pass the test. The active circuit of the CM2030 CEC line would react with the LCR meter and cause false capacitance readings. There is no issue with the operation of the CM2030 CEC line during normal operations. In fact, CM2030 CEC has shown to improve the signal integrity of the CEC line. CM2030 can be used for applications which do not require HDMI certification or applications which do not use the CEC line.

**HOTPLUG DETECT LOGIC**

The CM2030 ensures that the local ASIC will properly detect an HDMI compliant Sink. The current sink maintains a local logic “low” when no system is connected.

A valid pullup on the HDMI connector pin will overdrive the internal pulldown and deliver a logic “high” to the local ASIC.

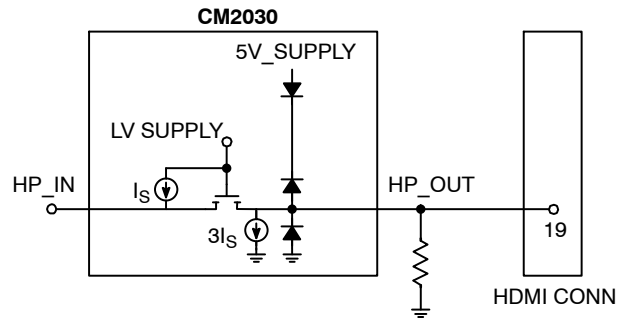

Figure 7. Hotplug Detect Circuit

A 15 KΩ pull down resistor should be connected between HP\_OUT and ground as required by HDMI specification. There should be no pull up on the HP\_IN, ASIC side of CM2030.

# CM2030

## SPECIFICATIONS

**Table 2. ABSOLUTE MAXIMUM RATINGS**

Parameter	Rating	Units
V <sub>CC5</sub> , V <sub>CCLV</sub>	6.0	V
DC Voltage at any Channel Input	[GND - 0.5] to [V <sub>CC</sub> + 0.5]	V
Storage Temperature Range	-65 to +150	°C

Stresses exceeding Maximum Ratings may damage the device. Maximum Ratings are stress ratings only. Functional operation above the Recommended Operating Conditions is not implied. Extended exposure to stresses above the Recommended Operating Conditions may affect device reliability.

**Table 3. STANDARD (RECOMMENDED) OPERATING CONDITIONS**

Symbol	Parameter	Min	Typ	Max	Units
5V_SUPPLY	Operating Supply Voltage	-	5	5.5	V
LV_SUPPLY	Bias Supply Voltage	1.0	3.3	5.5	V
CE_SUPPLY	Bias Supply Voltage	3.0	3.3	3.6	V
-	Operating Temperature Range	-40	-	85	°C

**Table 4. ELECTRICAL OPERATING CHARACTERISTICS** (Note 7)

Symbol	Parameter	Conditions	Min	Typ	Max	Units
I <sub>CC5</sub>	Operating Supply Current	5V_SUPPLY = 5.0 V, CEC_OUT = 3.3 V, LV_SUPPLY = 3.3 V, CE_SUPPLY = 3.3 V, DDC = 5 V (Note 12)		300	350	μA
I <sub>CCLV</sub>	Bias Supply Current	LV_SUPPLY = 3.3 V (Note 12)		60	150	μA
I <sub>CCCE</sub>	Bias Supply Current	CE_SUPPLY = 3.3 V, CEC_OUT = 0 V (Notes 12 and 13)		60	150	μA
I <sub>CEC</sub>	Current Source on CEC Pin	CE_SUPPLY = 3.3 V,	111	120	128	mA
V <sub>DROP</sub>	5V_OUT Overcurrent Out Put Drop	5V_SUPPLY = 5.0 V, I <sub>OUT</sub> = 55 mA		65	100	mV
I <sub>SC</sub>	5V_OUT Short Circuit Current Limit	5V_SUPPLY = 5.0 V, 5V_OUT = GND	90	135	175	mA
I <sub>OFF</sub>	OFF State Leakage Current, Level Shifting NFET	LV_SUPPLY = 0 V		0.1	5	μA
I <sub>BACKDRIVE, CEC</sub>	Current Through CE-REMOTE_OUT when Powered Down	CE-REMOTE_IN = CE_SUPPLY < CE_REMOTE_OUT		0.1	1.8	μA
I <sub>BACKDRIVE, TMDS</sub>	Current Through TMDS Pins when Powered Down	All Supplies = 0 V, TMDS_[2:0]±, TMDS_CK± = 4 V		0.1	5	μA
I <sub>BACKDRIVE, 5V_OUT</sub>	Current Through 5V_OUT when Powered Down	All Supplies = 0 V, 5V_OUT_PIN = 5 V		0.1	5	μA
I <sub>BACKDRIVE, DDC</sub>	Current Through DDC_DAT/CLK_OUT when Powered Down	All Supplies = 0 V, DDC_DAT/CLK_OUT = 5 V, DDC_DAT/CLK_IN = 0 V		0.1	5	μA
I <sub>BACKDRIVE, HOTPLUG</sub>	Current Through HOTPLUG_DET_OUT when Powered Down	All Supplies = 0 V, HOTPLUG_DET_OUT = 5 V, HOTPLUG_IN = 0 V		0.1	5	μA
CEC <sub>SL</sub>	CEC Slew Limit	Measured from 10–90% or 90–10%		0.26	0.65	V/μs

7. Operating Characteristics are over Standard Operating Conditions unless otherwise specified.

8. Standard IEC61000-4-2, C<sub>DISCHARGE</sub> = 150 pF, R<sub>DISCHARGE</sub> = 330 Ω, 5V\_SUPPLY = 5 V, 3.3V\_SUPPLY = 3.3 V, LV\_SUPPLY = 3.3 V, GND = 0 V.

9. Human Body Model per MIL-STD-883, Method 3015, C<sub>DISCHARGE</sub> = 100 pF, R<sub>DISCHARGE</sub> = 1.5 kΩ, 5V\_SUPPLY = 5V, 3.3V\_SUPPLY = 3.3 V, LV\_SUPPLY = 3.3 V, GND = 0 V.

10. Intra-pair matching, each TMDS pair (i.e. D+, D-)

11. These measurements performed with no external capacitor on V<sub>P</sub> (V<sub>P</sub> floating)

12. These static measurements do not include AC activity on controlled I/O lines.

13. This measurement does not include supply current for the 120 μA current source on the CEC pin.

# CM2030

**Table 4. ELECTRICAL OPERATING CHARACTERISTICS** (Note 7)

Symbol	Parameter	Conditions	Min	Typ	Max	Units
CEC <sub>RT</sub>	CEC Rise Time	Measured from 10–90% Assumes a signal swing from 0–3.3 V	26.4		250	μs
CEC <sub>FT</sub>	CEC Fall Time	Measured from 90–10% Assumes a signal swing from 0–3.3 V	4		50	μs
V <sub>ACC</sub>	Turn On Threshold of I <sup>2</sup> C / DDC Accelerator	Voltage is 0.3 ±10% X 5 V <sub>Supply</sub> (Note 8)	1.35	1.5	1.65	V
V <sub>ON(DDC_OUT)</sub>	Voltage Drop across DDC Level Shifter	LV_SUPPLY = 3.3 V, 3 mA Sink at DDC <sub>IN</sub> , DDC <sub>OUT</sub> < V <sub>ACC</sub>		150	225	mV
V <sub>OL(DDC_IN)</sub>	Logic Level (ASIC side) when I <sup>2</sup> C / DDC Logic Low Applied (I <sup>2</sup> C Pass-through Compatibility)	DDC_OUT = 0.4 V, LV_SUPPLY = 3.3 V, 1.5 kΩ pullup on DDC_OUT to 5.0 V (Note 8)		0.3	0.4	V
tr(DDC)	DDC_OUT Line Risetime, V <sub>ACC</sub> < V <sub>DDC_OUT</sub> < (5V <sub>Supply</sub> – 0.5 V)	DDC_IN floating, LV_SUPPLY = 3.3 V, 1.5 kΩ pullup on DDC_OUT to 5.0 V, Bus Capacitance = 1500 pF			1	μs
V <sub>F</sub>	Diode Forward Voltage Top Diode Bottom Diode	IF = 8 mA, T <sub>A</sub> = 25°C	0.6 0.6	0.85 0.85	0.95 0.95	V
V <sub>ESD</sub>	ESD Withstand Voltage (IEC)	Pins 4, 7, 10, 13, 20, 21, 22, 23, 24, 27, 30, 33, T <sub>A</sub> = 25°C (Note 8)	±8			kV
V <sub>ESD</sub>	ESD Withstand Voltage (HBM)	Pins 1, 2, 16, 17, 18, 19, 37, 38, T <sub>A</sub> = 25°C	±2			kV
V <sub>CL</sub>	Channel Clamp Voltage Positive Transients Negative Transients	T <sub>A</sub> = 25°C, I <sub>PP</sub> = 1 A, t <sub>P</sub> = 8/20 μS (Note 11)		11.0 2.0		V
R <sub>DYN</sub>	Dynamic Resistance Positive Transients Negative Transients	T <sub>A</sub> = 25°C, I <sub>PP</sub> = 1 A, t <sub>P</sub> = 8/20 μS Any I/O pin to Ground (Note 11)		1.4 0.9		Ω
I <sub>LEAK</sub>	TMDS Channel Leakage Current	T <sub>A</sub> = 25°C		0.01	1	μA
C <sub>IN, TMDS</sub>	TMDS Channel Input Capacitance	5V_SUPPLY = 5.0 V, Measured at 1 MHz, V <sub>BIAS</sub> = 2.5 V		0.9	1.2	pF
ΔC <sub>IN, TMDS</sub>	TMDS Channel Input Capacitance Matching	5V_SUPPLY = 5.0 V, Measured at 1 MHz, V <sub>BIAS</sub> = 2.5 V (Note 10)		0.05		pF
C <sub>MUTUAL</sub>	Mutual Capacitance between Signal Pin and Adja Cent Signal Pin	5V_SUPPLY = 0 V, Measured at 1 MHz, V <sub>BIAS</sub> = 2.5 V		0.07		pF
C <sub>IN, DDCOUT</sub>	Level Shifting Input Capacitance, Capacitance to GND	5V_SUPPLY = 0 V, Measured at 100 kHz, V <sub>BIAS</sub> = 2.5 V		10		pF
C <sub>IN, CECOUT</sub>	Level Shifting Input Capacitance, Capacitance to GND	5V_SUPPLY = 0 V, Measured at 100 kHz, V <sub>BIAS</sub> = 1.65 V		10		pF
C <sub>IN, HPOUT</sub>	Level Shifting Input Capacitance, Capacitance to GND	5V_SUPPLY = 0 V, Measured at 100 kHz, V <sub>BIAS</sub> = 2.5 V		10		pF

7. Operating Characteristics are over Standard Operating Conditions unless otherwise specified.

8. Standard IEC61000-4-2, C<sub>DISCHARGE</sub> = 150 pF, R<sub>DISCHARGE</sub> = 330 Ω, 5V\_SUPPLY = 5 V, 3.3V\_SUPPLY = 3.3 V, LV\_SUPPLY = 3.3 V, GND = 0 V.

9. Human Body Model per MIL-STD-883, Method 3015, C<sub>DISCHARGE</sub> = 100 pF, R<sub>DISCHARGE</sub> = 1.5 kΩ, 5V\_SUPPLY = 5V, 3.3V\_SUPPLY = 3.3 V, LV\_SUPPLY = 3.3 V, GND = 0 V.

10. Intra-pair matching, each TMDS pair (i.e. D+, D-)

11. These measurements performed with no external capacitor on V<sub>P</sub> (V<sub>P</sub> floating)

12. These static measurements do not include AC activity on controlled I/O lines.

13. This measurement does not include supply current for the 120 μA current source on the CEC pin.

PERFORMANCE INFORMATION

Typical Filter Performance ( $T_A = 25^\circ\text{C}$ , DC Bias = 0 V, 50  $\Omega$  Environment)

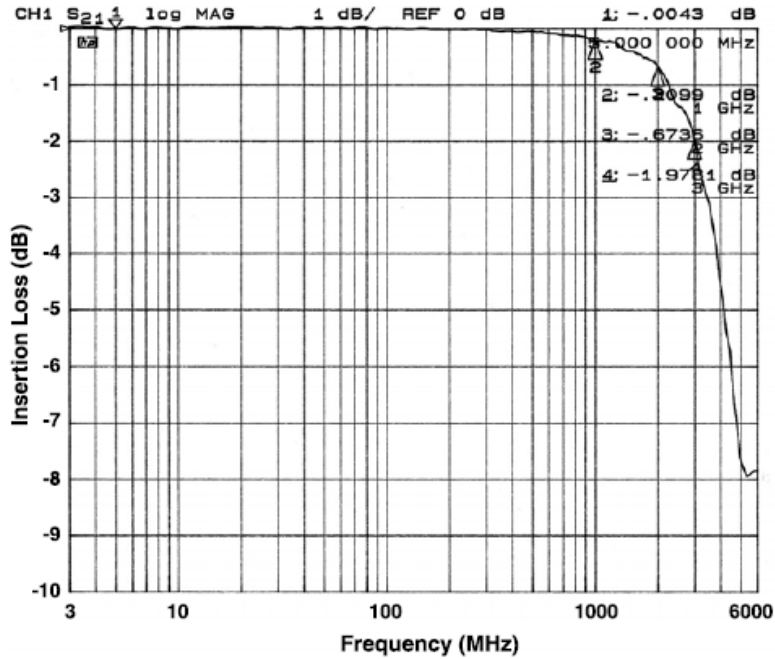

Figure 8. Insertion Loss vs. Frequency (TMDS\_D1- to GND)

APPLICATION INFORMATION

Design Considerations

5V\_OUT (pin 38)

Maximum overcurrent protection output drop at 55 mA on 5V\_OUT is 100 mV. To meet HDMI output requirements of 4.8–5.3 V, an input of greater than 4.9 V should be used (i.e. 5.1 V  $\pm 4\%$ )

DUT On vs. DUT Off

Many HDMI CTS tests require a power off condition on the System Under Test. Many discrete ESD diode configurations can be forward biased when their VDD rail is lower than the I/O pin bias, thereby exhibiting extremely high apparent capacitance measurements, for example. The *MediaGuard*<sup>™</sup> backdrive isolation circuitry limits this current to less than 5 mA, and will help ensure HDMI compliance.

# CM2030

## APPLICATION INFORMATION (Cont'd)

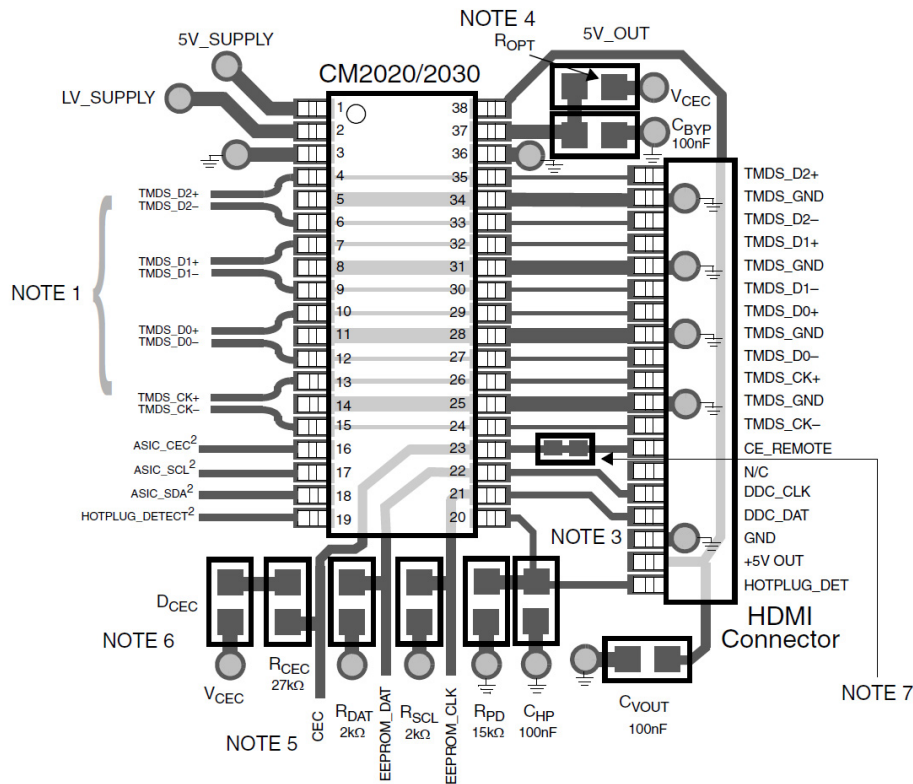

### LAYOUT NOTES

1) Differential TMDS Pairs should be designed as normal 100Ω HDMI Microstrip. Single Ended (decoupled) TMDS traces underneath MediaGuard™, and traces between MediaGuard™ and Connector should be tuned to match chip/connector IBIS parasitics.

2) Level Shifter signals should be biased with a weak pullup to the desired local LV\_SUPPLY. If the local ASIC includes sufficient pullups to register a logic high, then external pullups may not be needed.

3) Place MediaGuard™ as close to the connector as possible, and as with any controlled impedance line always avoid placing any silk-screen printing over TMDS traces.

4) CM2020/CM2030 footprint compatibility – For the CM2030, Pin 37 becomes the V\_CEC power supply pin for the slew-rate limiting circuitry. This can be supplied by a 0 Ω jumper to V\_CEC which should be depopulated to utilize the CM2020. The 100 nF C\_BYP is recommended for all applications.

5) CEC pullup isolation. The 27k R\_CEC and a Schottky D\_CEC provide the necessary isolation for the CEC pullup.

Note: This circuitry is used only in the CM2020. Depopulate the components for CM2030 applications in a CM2020/CM2030 dual footprint layout.

6) Footprint compatibility – The CM2030 has (built-in) internal backdrive protection.

The CM2020 does not have internal backdrive protection and requires the external R\_CEC and D\_CEC components.

7) (For CM2030) If CEC firmware is not implemented, do not populate with 0 Ω resistor. If CEC firmware is implemented, then populate with 0 Ω resistor. (For CM2020) Populate with 0 Ω resistor in either case.

Figure 9. Typical Application for CM2030

# CM2030

## PACKAGE DIMENSIONS

TSSOP 38  
CASE 948AG  
ISSUE O

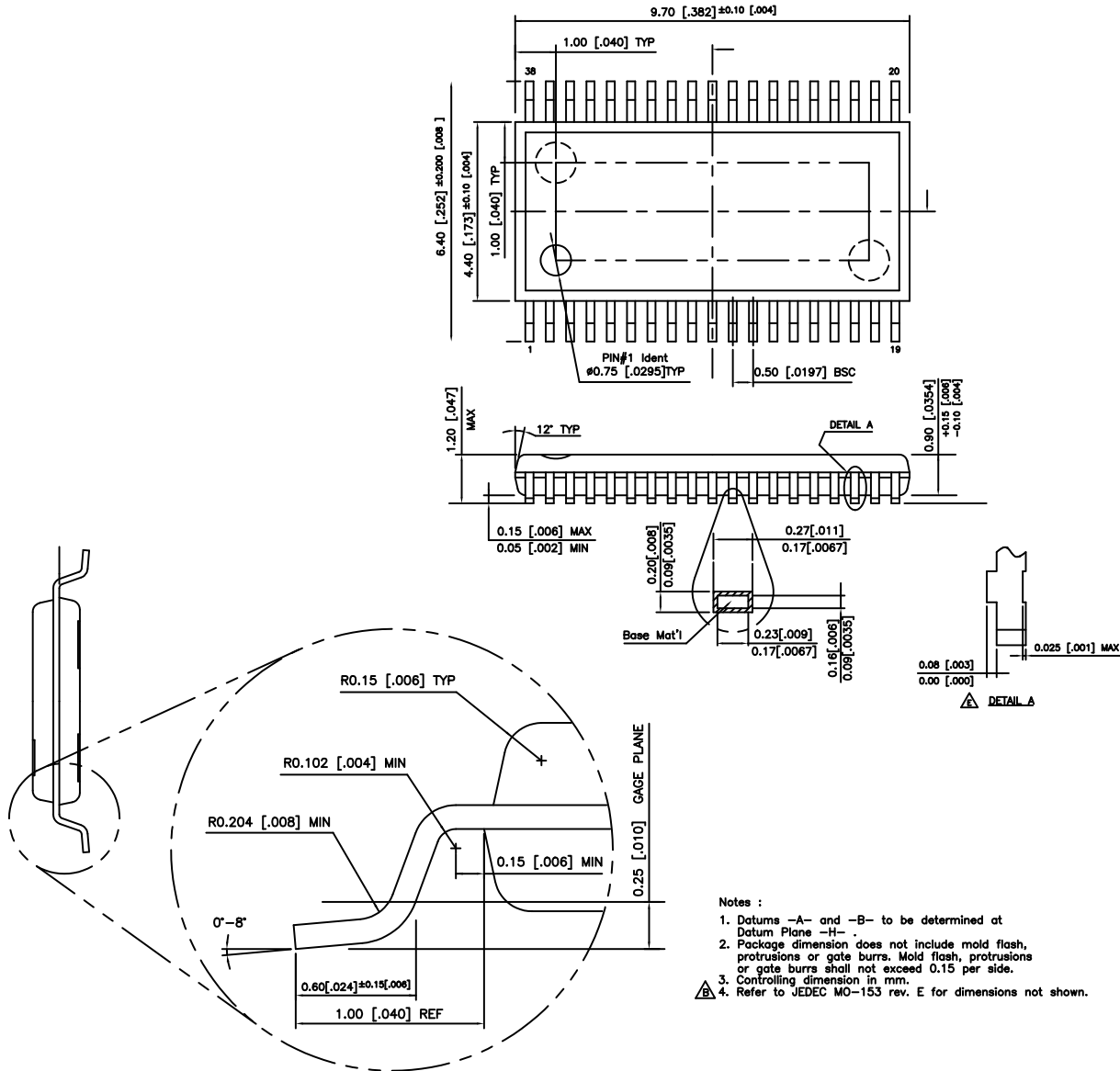

- Notes :
1. Datums -A- and -B- to be determined at Datum Plane -H-
  2. Package dimension does not include mold flash, protrusions or gate burrs. Mold flash, protrusions or gate burrs shall not exceed 0.15 per side.
  3. Controlling dimension in mm.
  4. Refer to JEDEC MO-153 rev. E for dimensions not shown.

MediaGuard is a trademark of Nagra France.

ON Semiconductor and are registered trademarks of Semiconductor Components Industries, LLC (SCILLC). SCILLC reserves the right to make changes without further notice to any products herein. SCILLC makes no warranty, representation or guarantee regarding the suitability of its products for any particular purpose, nor does SCILLC assume any liability arising out of the application or use of any product or circuit, and specifically disclaims any and all liability, including without limitation special, consequential or incidental damages. "Typical" parameters which may be provided in SCILLC data sheets and/or specifications can and do vary in different applications and actual performance may vary over time. All operating parameters, including "Typicals" must be validated for each customer application by customer's technical experts. SCILLC does not convey any license under its patent rights nor the rights of others. SCILLC products are not designed, intended, or authorized for use as components in systems intended for surgical implant into the body, or other applications intended to support or sustain life, or for any other application in which the failure of the SCILLC product could create a situation where personal injury or death may occur. Should Buyer purchase or use SCILLC products for any such unintended or unauthorized application, Buyer shall indemnify and hold SCILLC and its officers, employees, subsidiaries, affiliates, and distributors harmless against all claims, costs, damages, and expenses, and reasonable attorney fees arising out of, directly or indirectly, any claim of personal injury or death associated with such unintended or unauthorized use, even if such claim alleges that SCILLC was negligent regarding the design or manufacture of the part. SCILLC is an Equal Opportunity/Affirmative Action Employer. This literature is subject to all applicable copyright laws and is not for resale in any manner.

### PUBLICATION ORDERING INFORMATION



LITERATURE FULFILLMENT:  
Literature Distribution Center for ON Semiconductor  
P.O. Box 5163, Denver, Colorado 80217 USA  
Phone: 303-675-2175 or 800-344-3860 Toll Free USA/Canada  
Fax: 303-675-2176 or 800-344-3867 Toll Free USA/Canada  
Email: orderlit@onsemi.com

N. American Technical Support: 800-282-9855 Toll Free  
USA/Canada  
Europe, Middle East and Africa Technical Support:  
Phone: 421 33 790 2910  
Japan Customer Focus Center  
Phone: 81-3-5817-1050

ON Semiconductor Website: [www.onsemi.com](http://www.onsemi.com)  
Order Literature: <http://www.onsemi.com/orderlit>  
For additional information, please contact your local Sales Representative

## Looking for pricing, stock, or lifecycle information?

Click below to explore more details on WIN SOURCE:

-  [View CM2030-A0TR on WIN SOURCE](#)
-  [ON Semiconductor](#) Information

## Optimize Your Supply Chain with WIN SOURCE Solutions

-  Global Sourcing Solution
-  Obsolete Management
-  Cost Control Management
-  Shortage Management
-  Alternative Solution
-  Excess Inventory Management