



**THE DATASHEET OF  
CM2006-02QR**



# CM2006

## Praetorian<sup>®</sup> L-C LCD and Camera EMI Filter Array with ESD Protection

### Product Description

The CM2006 connects between the VGA or DVI-I port connector and the internal analog or digital flat panel controller logic. The CM2006 incorporates ESD protection for all signals, level shifting for the DDC signals and buffering for the SYNC signals. ESD protection for the video, DDC and SYNC lines is implemented with low-capacitance current steering diodes.

All connector interface pins are designed to safely handle the high current spikes specified by IEC-61000-4-2 Level 4 ( $\pm 8$  kV contact discharge). The ESD protection for the DDC, SYNC and VIDEO signal pins is designed to prevent “backdrive current” when the device is powered down while connected to a video source that is powered up.

Separate positive supply rails are provided for the VIDEO / SYNC signals and DDC signals to facilitate interfacing with low voltage video controller ICs and microcontrollers to provide design flexibility in multi-supply-voltage environments.

Two Schmitt-triggered non-inverting buffers redrive and condition the HSYNC and VSYNC signals from the video connector (SYNC1, SYNC2). These buffers accept VESA VSIS compliant TTL input signals and convert them to CMOS output levels that swing between ground and  $V_{CC}$ .

Two N-channel MOSFETs provide the level shifting function required when the DDC controller or EDID EEPROM is operated at a lower supply voltage than the monitor. The gate terminals for these MOSFETS ( $V_{CC\_DDC}$ ) should be connected to the supply rail (typically 3.3 V, 2.5 V, etc.) that supplies power to the transceivers of the DDC controller.

### Features

- Includes ESD Protection, Level-Shifting, Buffering and Sync Impedance Matching
- VESA VSIS Version 1 Revision 2 Compatible Interface
- Supports Optional NAVI Signalling Requirements
- 7 Channels of ESD Protection for all VGA Port Connector Pins. All Pins Meet IEC-61000-4-2 Level 4 ESD Requirements ( $\pm 8$  kV Contact Discharge)
- Very Low Loading Capacitance from ESD Protection Diodes on VIDEO Lines (3 pF Maximum)
- Schmitt-Triggered Input Buffers for HSYNC and VSYNC Lines
- These Devices are Pb-Free and are RoHS Compliant

### Applications

- VGA and DVI-I Ports in:
  - ◆ Monitors
  - ◆ TVs



ON Semiconductor<sup>®</sup>

[www.onsemi.com](http://www.onsemi.com)

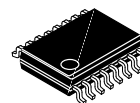

QSOP16  
QR SUFFIX  
CASE 492

### MARKING DIAGRAM

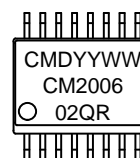

CM2006-02QR = Specific Device Code  
YY = Year  
WW = Work Week

### ORDERING INFORMATION

Device	Package	Shipping <sup>†</sup>
CM2006-02QR	QSOP-16 (Pb-Free)	2500/Tape & Reel

<sup>†</sup>For information on tape and reel specifications, including part orientation and tape sizes, please refer to our Tape and Reel Packaging Specification Brochure, BRD8011/D.

- Bidirectional Level Shifting N-Channel FETs Provided for DDC\_CLK & DDC\_DATA Channels
- Backdrive Protection on all Lines
- Compact 16-Lead QSOP Package

# CM2006

## ELECTRICAL SCHEMATIC

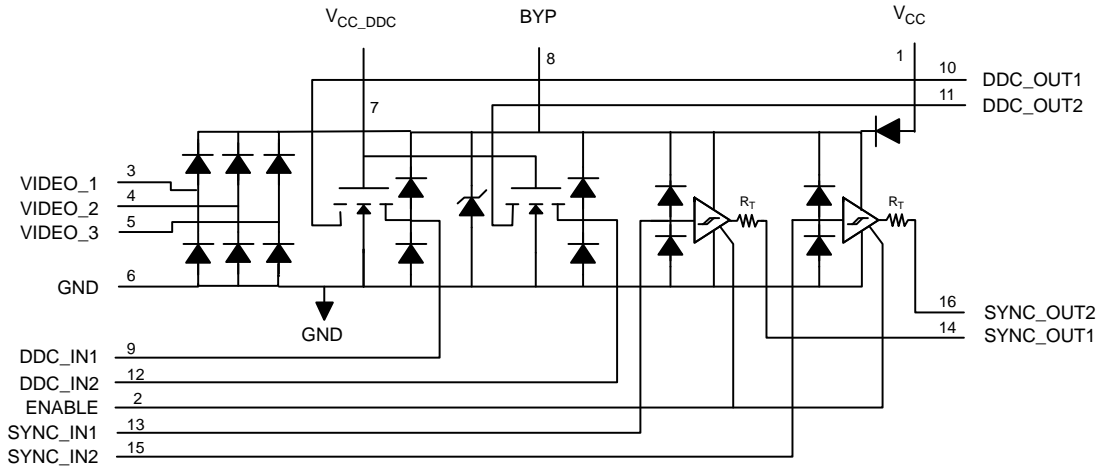

## PACKAGE / PINOUT DIAGRAM

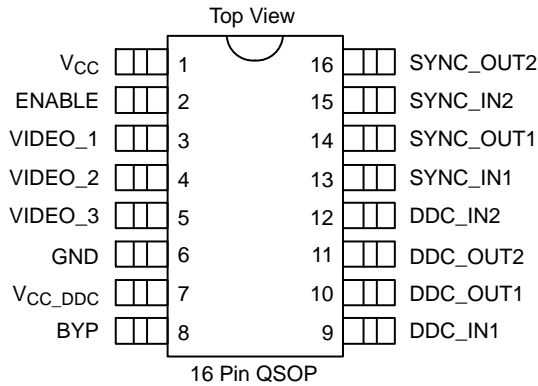

Table 1. PIN DESCRIPTIONS

Lead(s)	Name	Description
1	V <sub>CC</sub>	This is a supply input for the SYNC_1 and SYNC_2 level shifters, video protection and the DDC circuits.
2	ENABLE	Active high enable. Disables the Sync buffer outputs when low.
3	VIDEO_1	Video signal ESD protection channel. This pin is typically tied one of the video lines between the controller device and the video connector.
4	VIDEO_2	Video signal ESD protection channel. This pin is typically tied one of the video lines between the controller device and the video connector.
5	VIDEO_3	Video signal ESD protection channel. This pin is typically tied one of the video lines between the controller device and the video connector.
6	GND	Ground reference supply pin.
7	V <sub>CC_DDC</sub>	This is an isolated supply input for the DDC_1 and DDC_2 level-shifting N-FET gates.
8	BYP	An external 0.22 $\mu$ F bypass capacitor is required on this pin.
9	DDC_IN1	DDC signal input. Connects to the video connector side of one of the DDC lines.signal output.
10	DDC_OUT1	DDC signal output. Connects to the monitor DDC logic.
11	DDC_OUT	DDC signal output. Connects to the monitor DDC logic.
12	DDC_IN2	DDC signal input. Connects to the video connector side of one of the DDC lines
13	SYNC_IN1	Sync signal buffer input. Connects to the video connector side of one of the sync lines.
14	SYNC_OUT1	Sync signal buffer output. Connects to the monitor SYNC logic.
15	SYNC_IN2	Sync signal buffer input. Connects to the video connector side of one of the sync lines.
16	SYNC_OUT2	Sync signal buffer output. Connects to the monitor SYNC logic.

# CM2006

## SPECIFICATIONS

**Table 2. ABSOLUTE MAXIMUM RATINGS**

Parameter	Rating	Units
$V_{CC\_DDC}$ and $V_{CC}$ Supply Voltage Inputs	[GND – 0.5] to +6.0	V
DC Voltage at Inputs VIDEO_1, VIDEO_2, VIDEO_3 DDC_IN1, DDC_IN2 DDC_OUT1, DDC_OUT2 SYNC_IN1, SYNC_IN2, ENABLE	[GND – 0.5] to [ $V_{CC} + 0.5$ ] [GND – 0.5] to 6.0 [GND – 0.5] to 6.0 [GND – 0.5] to [ $V_{CC} + 0.5$ ]	V
Operating Temperature Range	–40 to +85	°C
Storage Temperature Range	–40 to +150	°C
Package Power Rating ( $T_A = 25^\circ\text{C}$ )	500	mW

Stresses exceeding those listed in the Maximum Ratings table may damage the device. If any of these limits are exceeded, device functionality should not be assumed, damage may occur and reliability may be affected.

**Table 3. STANDARD OPERATING CONDITIONS**

Parameter	Rating	Units
Operating Temperature Range	–40 to +85	°C
$V_{CC}$	5	V

Functional operation above the stresses listed in the Recommended Operating Ranges is not implied. Extended exposure to stresses beyond the Recommended Operating Ranges limits may affect device reliability.

# CM2006

**Table 4. ELECTRICAL OPERATING CHARACTERISTICS** (Note 1)

Symbol	Parameter	Conditions	Min	Typ	Max	Units
I <sub>CC_DDC</sub>	V <sub>CC_DDC</sub> Supply Current	V <sub>CC_DDC</sub> = 5.0 V			10	μA
I <sub>CC</sub>	V <sub>CC</sub> Supply Current	V <sub>CC</sub> = 5 V; SYNC inputs at GND or V <sub>CC</sub> ; SYNC outputs unloaded			1	mA
		V <sub>CC</sub> = 5 V; SYNC inputs at 3.0 V; SYNC outputs unloaded			2.0	mA
V <sub>F</sub>	ESD Diode Forward Voltage	I <sub>F</sub> = 10 mA			1.0	V
V <sub>IH</sub>	Logic High Input Voltage	V <sub>CC</sub> = 5.0 V; (Note 2)	2.0			V
V <sub>IL</sub>	Logic Low Input Voltage	V <sub>CC</sub> = 5.0 V; (Note 2)			0.5	V
V <sub>HYS</sub>	Hysteresis Voltage	V <sub>CC</sub> = 5.0 V; (Note 2)		400		mV
V <sub>OH</sub>	Logic High Output Voltage	I <sub>OH</sub> = 0 mA, V <sub>CC</sub> = 5.0 V; (Note 2)	4.0			V
V <sub>OL</sub>	Logic Low Output Voltage	I <sub>OL</sub> = 0 mA, V <sub>CC</sub> = 5.0 V; (Note 2)			0.15	V
R <sub>OUT</sub>	SYNC Driver Output Resistance	V <sub>CC</sub> = 5.0 V; SYNC Inputs at GND or 3.0 V	7	15	24	Ω
I <sub>IN</sub>	Input Current VIDEO Inputs	V <sub>CC</sub> = 5.0 V; V <sub>IN</sub> = V <sub>CC</sub> or GND			±10	μA
	SYNC_IN1, SYNC_IN2 Inputs	V <sub>CC</sub> = 5.0 V; V <sub>IN</sub> = V <sub>CC</sub> or GND			±10	μA
I <sub>OFF</sub>	Level Shifting N-MOSFET "OFF" State Leakage Current	(V <sub>CC_DDC</sub> - V <sub>DDC_IN</sub> ) < 0.4 V; V <sub>DDC_OUT</sub> = V <sub>CC_DDC</sub>			10	μA
		(V <sub>CC_DDC</sub> - V <sub>DDC_OUT</sub> ) < 0.4 V; V <sub>DDC_IN</sub> = V <sub>CC_DDC</sub>			10	μA
I <sub>BACKDRIVE</sub>	Current conducted from input pins when V <sub>CC</sub> is powered down.	V <sub>CC</sub> < V <sub>INPUT_PIN</sub> ; (Note 5)		10		μA
V <sub>ON</sub>	Voltage Drop Across Level-shifting N-MOSFET when "ON"	V <sub>CC_DDC</sub> = 2.5 V; V <sub>S</sub> = GND; I <sub>DS</sub> = 3 mA			0.18	V
C <sub>IN_VID</sub>	VIDEO Input Capacitance	V <sub>CC</sub> = 5.0 V; V <sub>IN</sub> = 2.5 V; f = 1 MHz			3	pF
		V <sub>CC</sub> = 2.5 V; V <sub>IN</sub> = 1.25 V; f = 1 MHz			3.5	pF
t <sub>PLH</sub>	SYNC Driver L => H Propagation Delay	C <sub>L</sub> = 50 pF; V <sub>CC</sub> = 5.0 V; Input t <sub>R</sub> and t <sub>F</sub> < 5 ns			12	ns
t <sub>PHL</sub>	SYNC Driver H => L Propagation Delay	C <sub>L</sub> = 50 pF; V <sub>CC</sub> = 5.0 V; Input t <sub>R</sub> and t <sub>F</sub> < 5 ns			12	ns
t <sub>R</sub> , t <sub>F</sub>	SYNC Driver Output Rise & Fall Times	C <sub>L</sub> = 50 pF; V <sub>CC</sub> = 5.0 V; Input t <sub>R</sub> and t <sub>F</sub> < 5 ns		3		ns
V <sub>ESD1</sub>	ESD Withstand Voltage, Sync_out pins only	V <sub>CC</sub> = 5 V; (Notes 3 and 4)	±2			kV
V <sub>ESD</sub>	ESD Withstand Voltage	V <sub>CC</sub> = 5 V; (Notes 3 and 5)	±8			kV

Product parametric performance is indicated in the Electrical Characteristics for the listed test conditions, unless otherwise noted. Product performance may not be indicated by the Electrical Characteristics if operated under different conditions.

1. All parameters specified over standard operating conditions unless otherwise noted.
2. These parameters apply only to the SYNC drivers. Note that R<sub>OUT</sub> = R<sub>T</sub> + R<sub>BUFFER</sub>.
3. Per the IEC-61000-4-2 International ESD Standard, Level 4 contact discharge method. BYP and V<sub>CC</sub> must be bypassed to GND via a low impedance ground plane with a 0.22 μF, low inductance, chip ceramic capacitor at each supply pin. ESD pulse is applied between the applicable pins and GND. ESD pulses can be positive or negative with respect to GND. Applicable pins are: VIDEO\_1, VIDEO\_2, VIDEO\_3, SYNC\_IN1, SYNC\_IN2, DDC\_IN1 and DDC\_IN2. All pins are ESD protected to the industry standard ±2 kV Human Body Model (MIL-STD-883, Method 3015).
4. This specification applies to the SYNC\_OUT pins only.
5. Applicable pins are: VIDEO\_1, VIDEO\_2, VIDEO\_3, SYNC\_IN1, SYNC\_IN2, DDC\_IN1 and DDC\_IN2.

APPLICATION INFORMATION

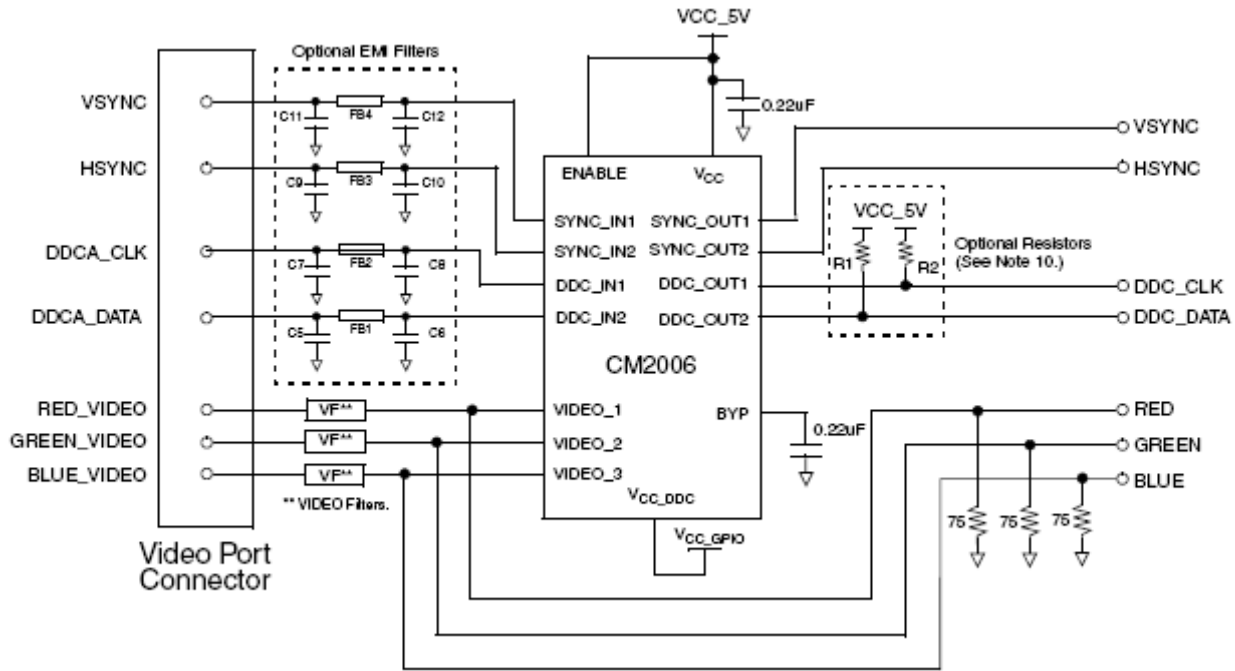

Figure 1. Typical Application Connection Diagram

NOTES:

1. The CM2006 should be placed as close to the VGA or DVI-I connector as possible.
2. The ESD protection channels VIDEO\_1, VIDEO\_2, VIDEO\_3 may be used interchangeably between the R, G, B signals.
3. If differential video signal routing is used, the RED, BLUE, and GREEN signal lines should be terminated with external 37.5 Ω resistors.
4. “VF” are external video filters for the RGB signals.
5. Supply bypass capacitors C1 and C2 must be placed immediately adjacent to the corresponding Vcc pins. Connections to the Vcc pins and ground plane must be made with minimal length copper traces (preferably less than 5 mm) for best ESD protection.
6. The bypass capacitor for the BYP pin has been omitted in this diagram. This results in a reduction in the maximum ESD withstand voltage at the DDC\_OUT pins from ±8 kV to ±2 kV. If 8 kV ESD protection is required, a 0.22 µF ceramic bypass capacitor should be connected between BYP and ground.
7. The SYNC buffers may be used interchangeably between HSYNC and VSYNC.
8. The EMI filters at the SYNC\_OUT and DDC\_OUT pins (C5 to C12, and Ferrite Beads FB1 to FB4) are for reference only. The component values and filter configuration may be changed to suit the application.
9. The DDC level shifters DDC\_IN, DDC\_OUT, may be used interchangeably between DDCA\_CLK and DDCA\_DATA.
10. R1, R2 are optional. They may be used, if required, to pull the DDC\_CLK and DDC\_DATA lines to VCC\_5V when no VGA card is connected to the VGA monitor. If used, it should be noted that “back current” may flow between the DDC pins and VCC\_5V via these resistors when VCC\_5V is powered down.

# MECHANICAL CASE OUTLINE PACKAGE DIMENSIONS

ON Semiconductor®

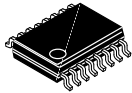

SCALE 2:1

## QSOP16 CASE 492-01 ISSUE A

DATE 23 MAR 2011

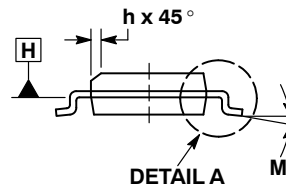
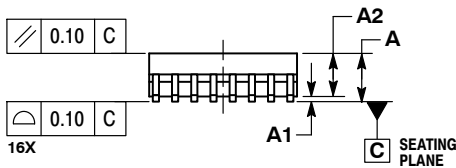
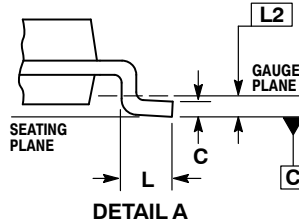
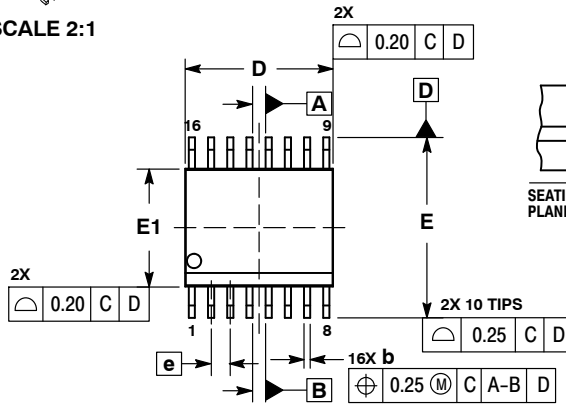

NOTES:

1. DIMENSIONING AND TOLERANCING PER ASME Y14.5M, 1994.
2. CONTROLLING DIMENSION: MILLIMETERS.
3. DIMENSION b DOES NOT INCLUDE DAMBAR PROTRUSION.
4. DIMENSION D DOES NOT INCLUDE MOLD FLASH, PROTRUSIONS, OR GATE BURRS. MOLD FLASH, PROTRUSIONS, OR GATE BURRS SHALL NOT EXCEED 0.005 PER SIDE. DIMENSION E1 DOES NOT INCLUDE INTERLEAD FLASH OR PROTRUSION. INTERLEAD FLASH OR PROTRUSION SHALL NOT EXCEED 0.005 PER SIDE. D AND E1 ARE DETERMINED AT DATUM H.
5. DATUMS A AND B ARE DETERMINED AT DATUM H.

DIM	INCHES		MILLIMETERS	
	MIN	MAX	MIN	MAX
A	0.053	0.069	1.35	1.75
A1	0.004	0.010	0.10	0.25
A2	0.049	----	1.24	----
b	0.008	0.012	0.20	0.30
c	0.007	0.010	0.19	0.25
D	0.193 BSC		4.89 BSC	
E	0.237 BSC		6.00 BSC	
E1	0.154 BSC		3.90 BSC	
e	0.025 BSC		0.635 BSC	
h	0.009	0.020	0.22	0.50
L	0.016	0.050	0.40	1.27
L2	0.010 BSC		0.25 BSC	
M	0°	8°	0°	8°

### SOLDERING FOOTPRINT

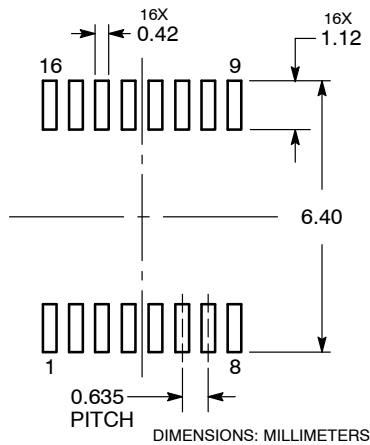

### GENERIC MARKING DIAGRAM\*

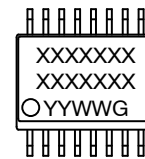

- XXXXXX = Specific Device Code
- YY = Year
- WW = Work Week
- G = Pb-Free Package

\*This information is generic. Please refer to device data sheet for actual part marking. Pb-Free indicator, "G", may or not be present.

<b>DOCUMENT NUMBER:</b>	<b>98AON04472D</b>	Electronic versions are uncontrolled except when accessed directly from the Document Repository. Printed versions are uncontrolled except when stamped "CONTROLLED COPY" in red.
<b>DESCRIPTION:</b>	<b>QSOP16</b>	<b>PAGE 1 OF 1</b>

ON Semiconductor and are trademarks of Semiconductor Components Industries, LLC dba ON Semiconductor or its subsidiaries in the United States and/or other countries. ON Semiconductor reserves the right to make changes without further notice to any products herein. ON Semiconductor makes no warranty, representation or guarantee regarding the suitability of its products for any particular purpose, nor does ON Semiconductor assume any liability arising out of the application or use of any product or circuit, and specifically disclaims any and all liability, including without limitation special, consequential or incidental damages. ON Semiconductor does not convey any license under its patent rights nor the rights of others.

**onsemi**, **Onsemi**, and other names, marks, and brands are registered and/or common law trademarks of Semiconductor Components Industries, LLC dba "**onsemi**" or its affiliates and/or subsidiaries in the United States and/or other countries. **onsemi** owns the rights to a number of patents, trademarks, copyrights, trade secrets, and other intellectual property. A listing of **onsemi**'s product/patent coverage may be accessed at [www.onsemi.com/site/pdf/Patent-Marking.pdf](http://www.onsemi.com/site/pdf/Patent-Marking.pdf). **onsemi** reserves the right to make changes at any time to any products or information herein, without notice. The information herein is provided "as-is" and **onsemi** makes no warranty, representation or guarantee regarding the accuracy of the information, product features, availability, functionality, or suitability of its products for any particular purpose, nor does **onsemi** assume any liability arising out of the application or use of any product or circuit, and specifically disclaims any and all liability, including without limitation special, consequential or incidental damages. Buyer is responsible for its products and applications using **onsemi** products, including compliance with all laws, regulations and safety requirements or standards, regardless of any support or applications information provided by **onsemi**. "Typical" parameters which may be provided in **onsemi** data sheets and/or specifications can and do vary in different applications and actual performance may vary over time. All operating parameters, including "Typicals" must be validated for each customer application by customer's technical experts. **onsemi** does not convey any license under any of its intellectual property rights nor the rights of others. **onsemi** products are not designed, intended, or authorized for use as a critical component in life support systems or any FDA Class 3 medical devices or medical devices with a same or similar classification in a foreign jurisdiction or any devices intended for implantation in the human body. Should Buyer purchase or use **onsemi** products for any such unintended or unauthorized application, Buyer shall indemnify and hold **onsemi** and its officers, employees, subsidiaries, affiliates, and distributors harmless against all claims, costs, damages, and expenses, and reasonable attorney fees arising out of, directly or indirectly, any claim of personal injury or death associated with such unintended or unauthorized use, even if such claim alleges that **onsemi** was negligent regarding the design or manufacture of the part. **onsemi** is an Equal Opportunity/Affirmative Action Employer. This literature is subject to all applicable copyright laws and is not for resale in any manner.

## ADDITIONAL INFORMATION

### TECHNICAL PUBLICATIONS:

Technical Library: [www.onsemi.com/design/resources/technical-documentation](http://www.onsemi.com/design/resources/technical-documentation)  
onsemi Website: [www.onsemi.com](http://www.onsemi.com)

### ONLINE SUPPORT: [www.onsemi.com/support](http://www.onsemi.com/support)

For additional information, please contact your local Sales Representative at [www.onsemi.com/support/sales](http://www.onsemi.com/support/sales)

## Looking for pricing, stock, or lifecycle information?

Click below to explore more details on WIN SOURCE:

 [View CM2006-02QR](#) on WIN SOURCE

 [ON Semiconductor](#) Information

## Optimize Your Supply Chain with WIN SOURCE Solutions

-  Global Sourcing Solution
-  Obsolete Management
-  Cost Control Management
-  Shortage Management
-  Alternative Solution
-  Excess Inventory Management