



**THE DATASHEET OF
CGGBP.35.2.A.08**





TAOGLAS®



Datasheet

Part No:
CGGBP.35.2.A.08

Description:
35mm*35mm*2mm GPS/GLONASS/Galileo/BeiDou/QZSS
Ceramic Patch Antenna

Features:
Stable gain across most major GNSS applications
Excellent radiation pattern coverage
Low profile
Dielectric Ceramic
Pin (Through hole) Mount
RoHS & Reach Compliant

1. Introduction	3
2. Specifications	4
3. Antenna Characteristics	6
4. Radiation Patterns	9
5. Mechanical Drawing	12
6. Antenna Integration Guide	13
7. Evaluation Board Mechanical Drawing	19
8. PCB Footprint Recommendation	20
9. Packaging	21
Changelog	22

Taoglas makes no warranties based on the accuracy or completeness of the contents of this document and reserves the right to make changes to specifications and product descriptions at any time without notice. Taoglas reserves all rights to this document and the information contained herein. Reproduction, use or disclosure to third parties without express permission is strictly prohibited.



1. Introduction



This CGGBP.35 35mm*35mm embedded ceramic GPS/GLONASS/Galileo/ BeiDou patch antenna has a wide band of operation, leading to excellent gain and radiation pattern stability on all three GNSS system bands. The CGGBP.35.2 is ideal for devices where height may be at a premium, at just 2mm this low profile patch antenna can be placed in areas where thicker antennas may not fit.

Typical Applications Include:

- Wearables
- Navigation
- Transportation
- RTK

Compared to using a smaller antenna, this will translate into the GNSS system having much higher location accuracy, improved reliability of lock in urban areas, better signal reception, with more satellites acquired and a quicker time to first fix.

The patch is mounted via pin and double-sided adhesive. This antenna has been manufactured in an IATF16969 approved facility.

While the antenna will operate well in most device environments (Note cannot be covered with metal enclosure), tuning and further optimization of this antenna to different ground-planes and enclosures can be done if required, also including a pin length change. These changes would be subject to possible NRE and a minimum order quantity. For further information contact your regional Taoglas customer support team

2. Specifications

GNSS Frequency Bands					
GPS	L1 1575.42 MHz	L2 1227.6 MHz	L5 1176.45 MHz		
	■	□	□		
GLONASS	G1 1602 MHz	G2 1248 MHz	G3 1207 MHz		
	■	□	□		
Galileo	E1 1575.24 MHz	E5a 1176.45 MHz	E5b 1201.5 MHz	E6 1278.75 MHz	
	■	□	□	□	
BeiDou	B1C 1575.42 MHz	B1I 1561 MHz	B2a 1176.45 MHz	B2b 1207.14 MHz	B3 1268.52 MHz
	■	■	□	□	□
L-Band	L-Band 1542 MHz				
	□				
QZSS (Regional)	L1 1575.42 MHz	L2C 1227.6 MHz	L5 1176.45 MHz	L6 1278.75e6	
	■	□	□	□	
IRNSS (Regional)	L5 1176.45 MHz				
	□				
SBAS	L1/E1/B1 1575.42 MHz	L5/B2a/E5a 1176.45 MHz	G1 1602 MHz	G2 1248 MHz	G3 1207 MHz
	■	□	■	□	□

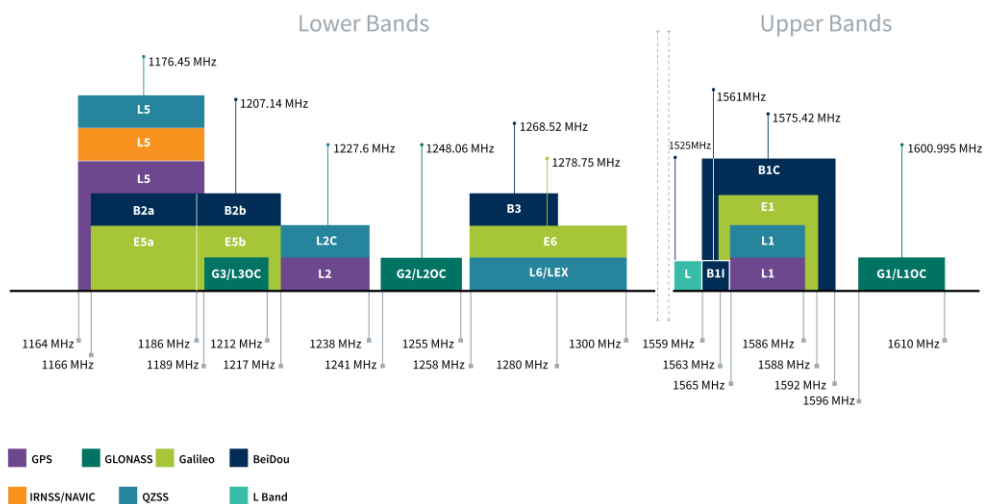

Bands and Constellations Table

GNSS Electrical			
Frequency (MHz)	1561	1575.42	1602
Efficiency (%)	58.60	59.94	71.33
Average Gain (dB)	-2.32	-2.22	-1.47
Peak Gain at Zenith (dBi)	3.45	3.68	4.87
Polarization	RHCP		
Impedance(Ω)	50		

Mechanical	
Dimensions	35 x 35 x 2mm
Material	Ceramic
Pin Diameter	0.85mm
Pin Length	2.4mm
Weight	8.6g
Environmental	
Temperature Range	-40°C to 85°C
Storage Temperature	-40°C to 105°C
Humidity	Non-condensing 65°C 95% RH

3. Antenna Characteristics

3.1 Return Loss

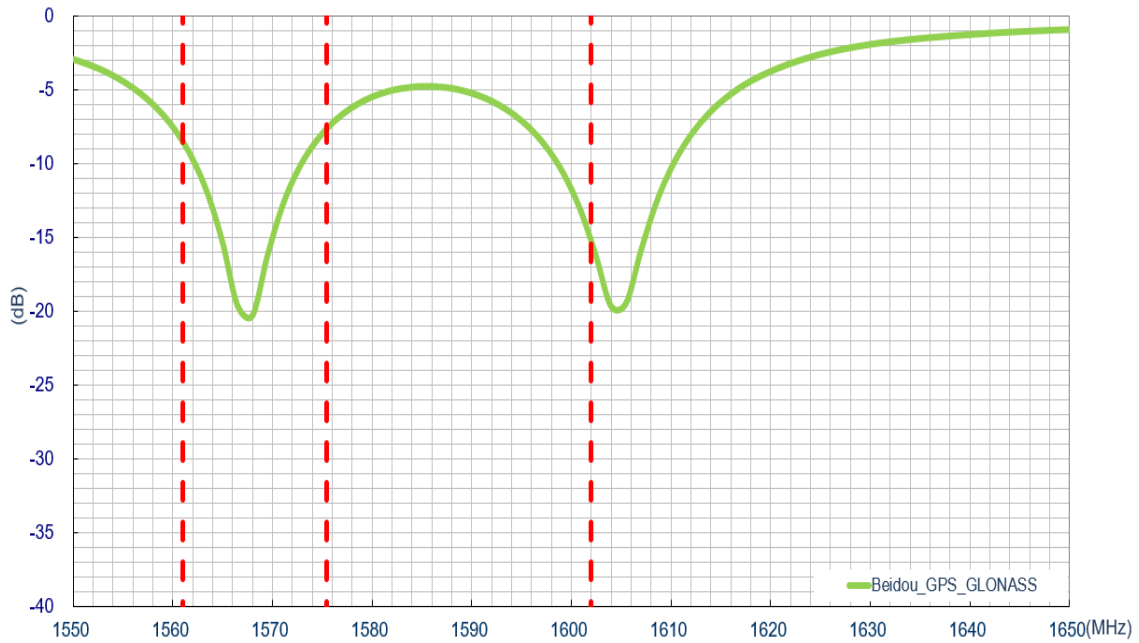

3.2 VSWR

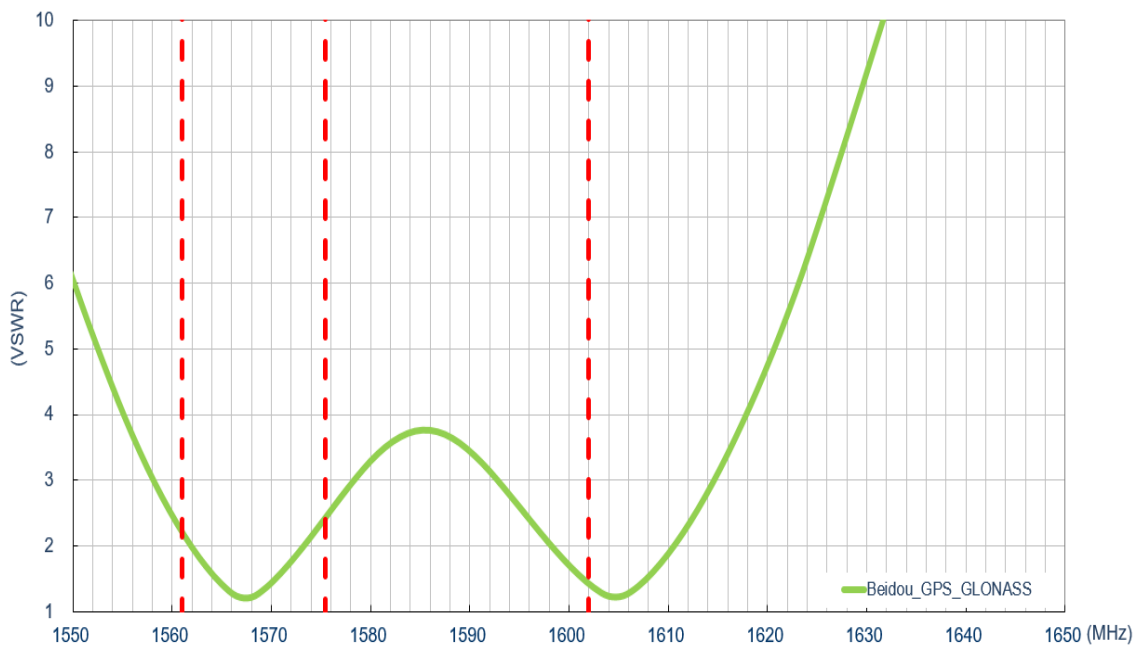

3.3 Efficiency

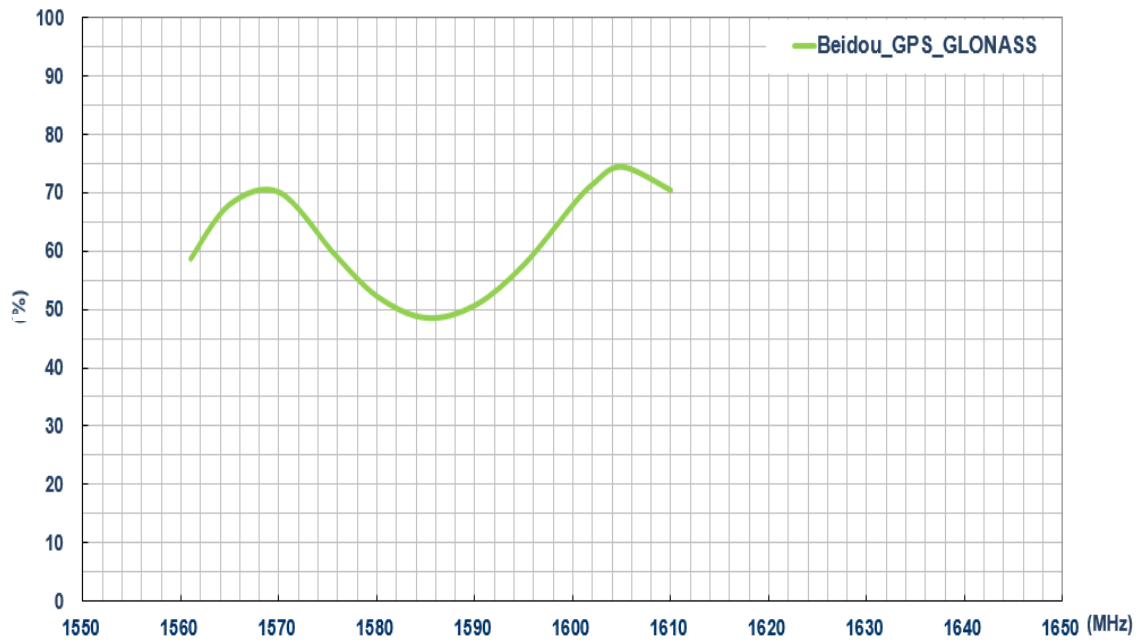

3.4 Average Gain

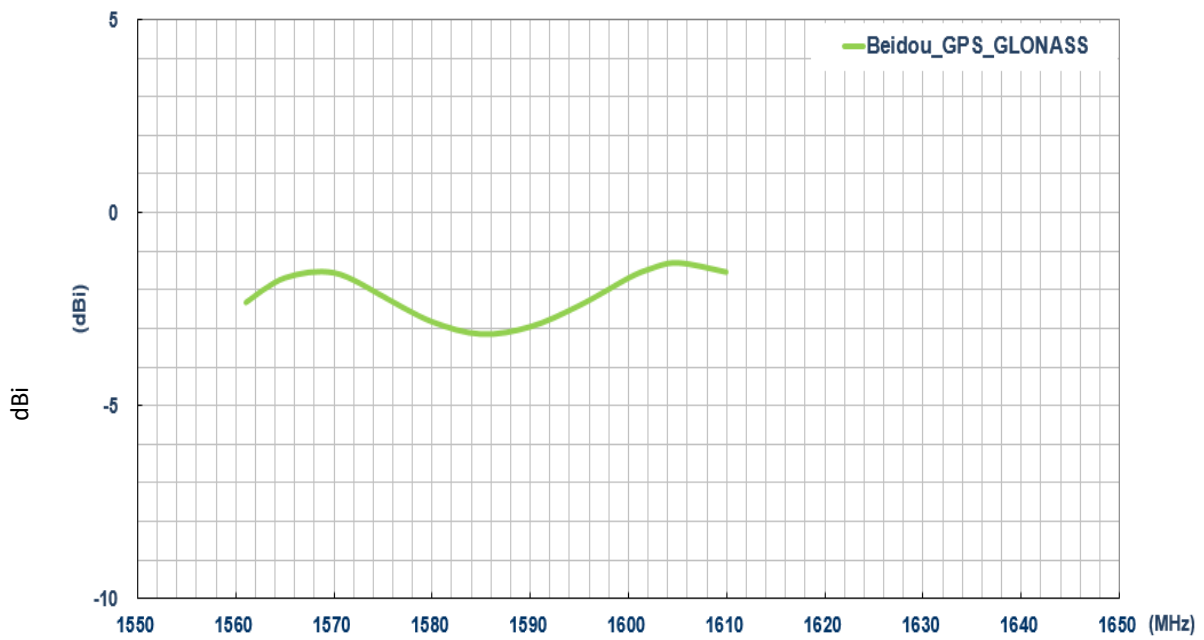

3.5 Peak Gain

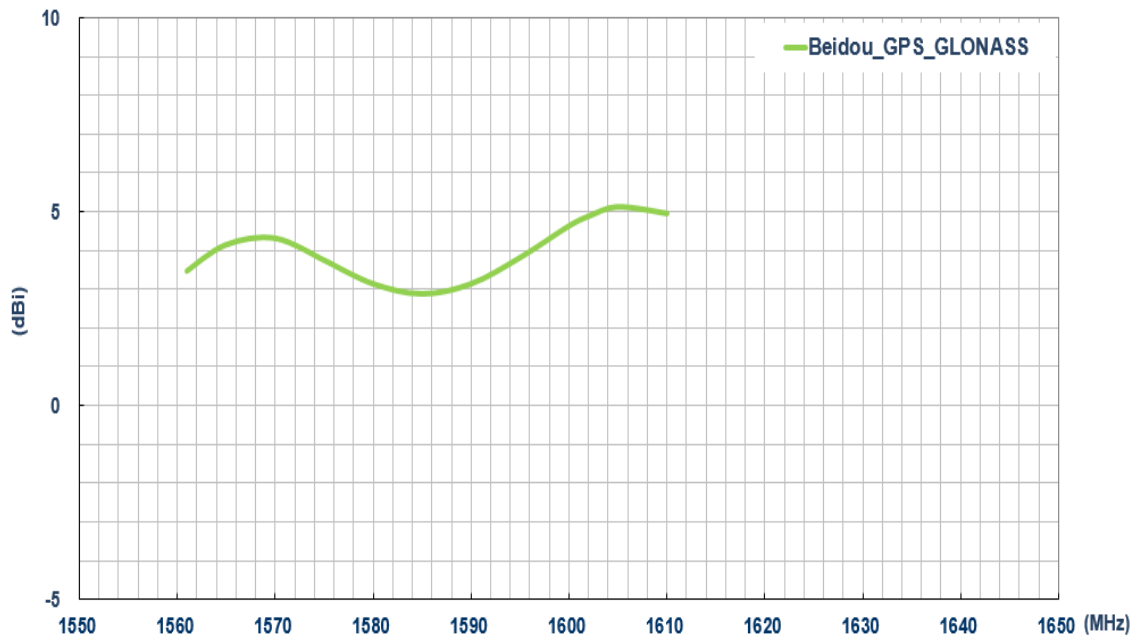

3.5 Smith Chart

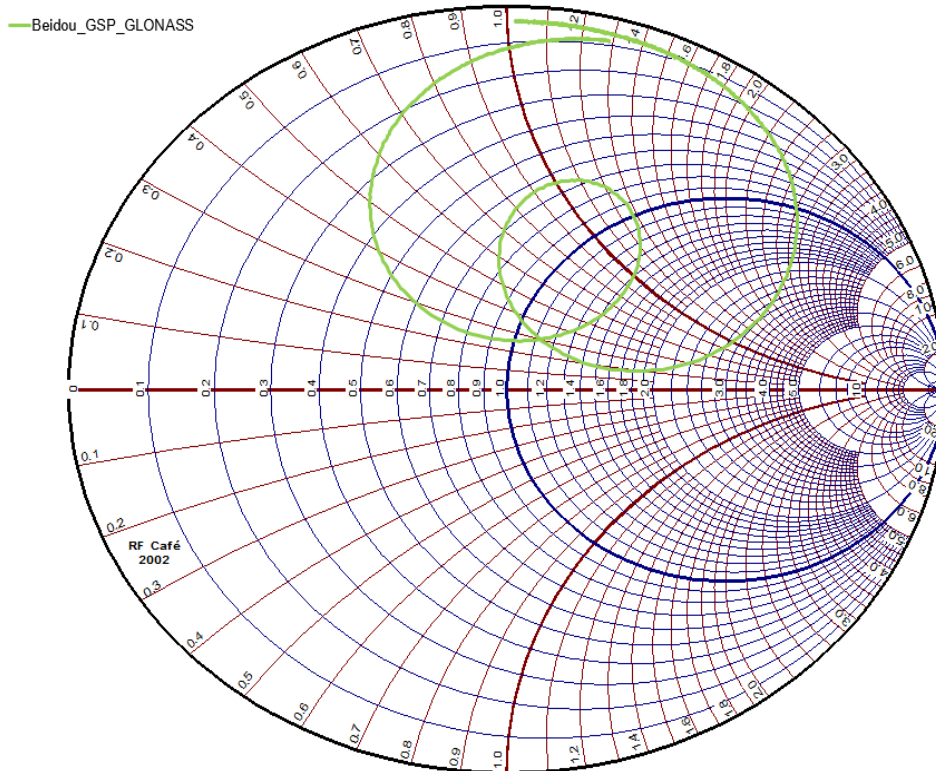

4. Radiation Patterns

4.1 Test Setup – on 70*70mm Ground Plane

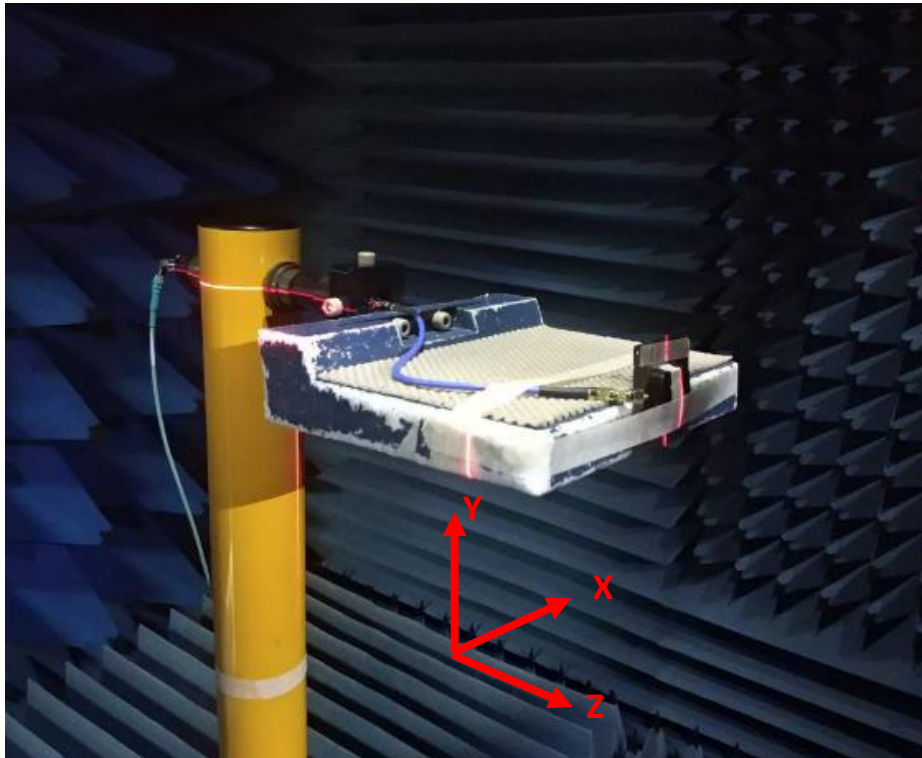

4.2 2D Radiation Patterns

XY Plane

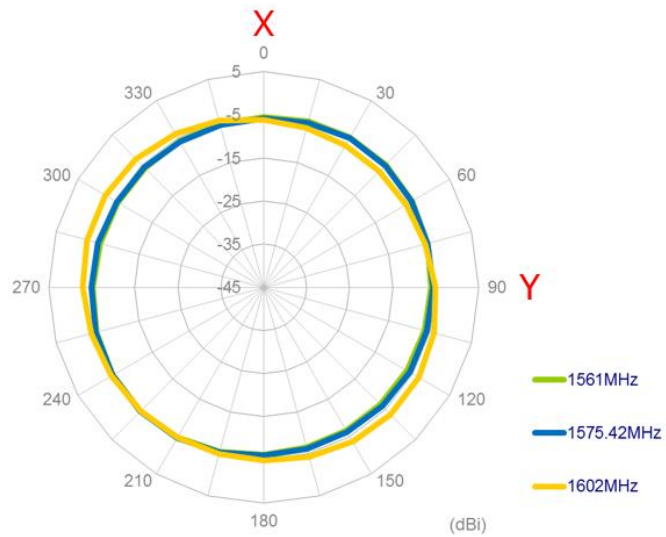

XZ Plane

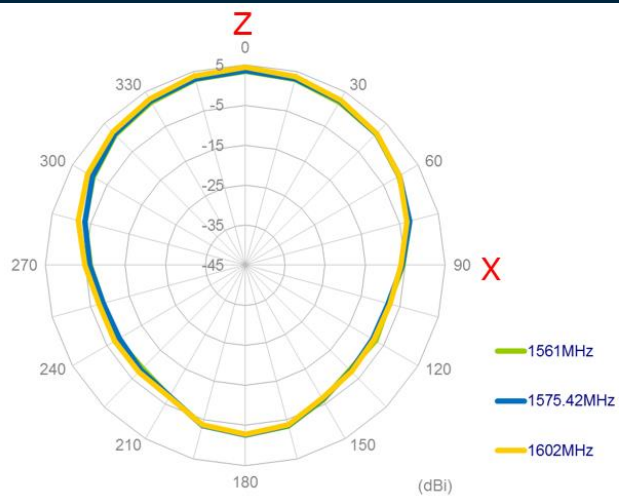

YZ Plane

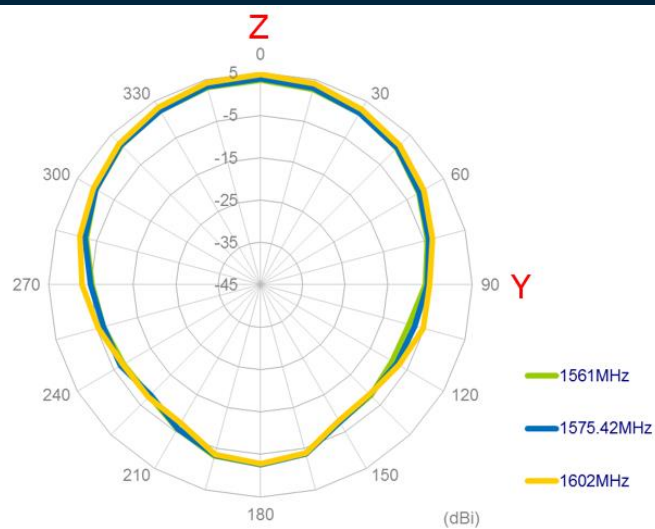

4.3 3D Radiation Patterns

1561MHz

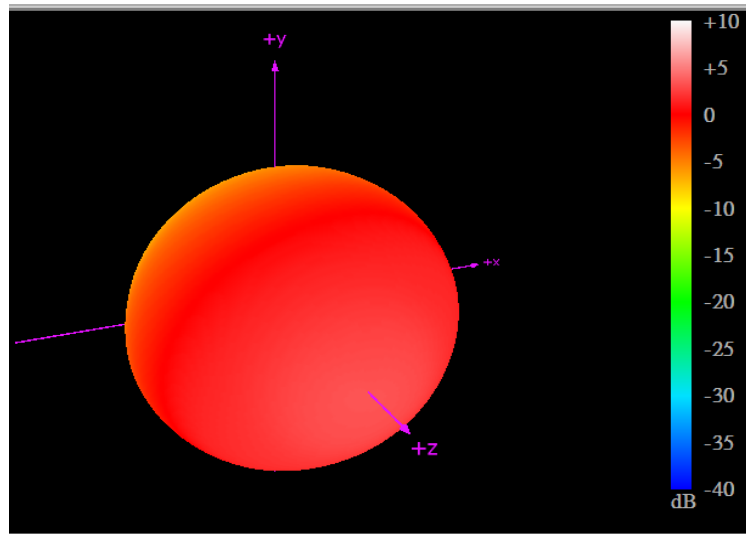

1575MHz

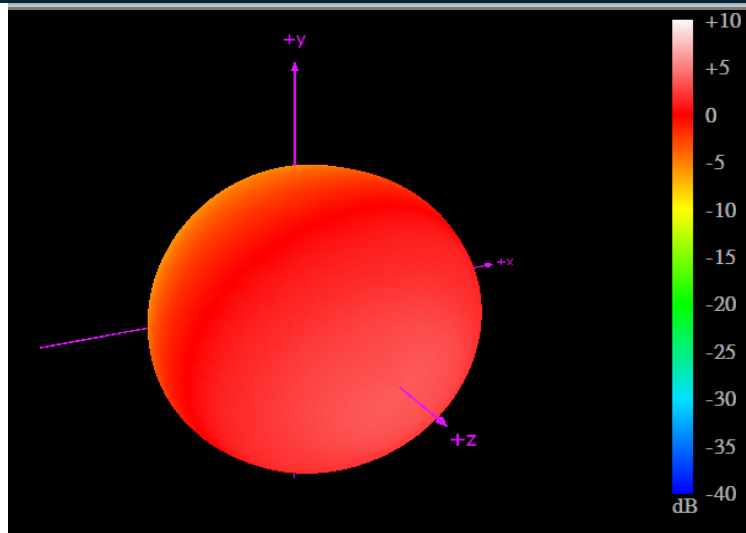

1602MHz

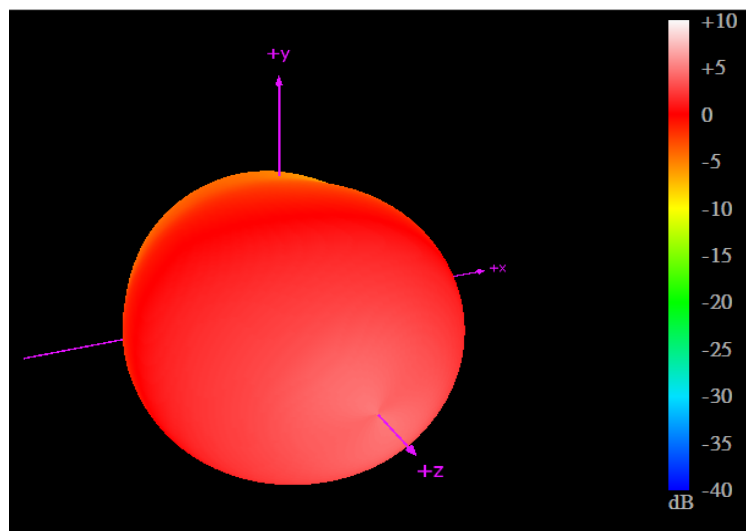

5. Mechanical Drawing (Units:mm)

5.1 Mechanical Drawing

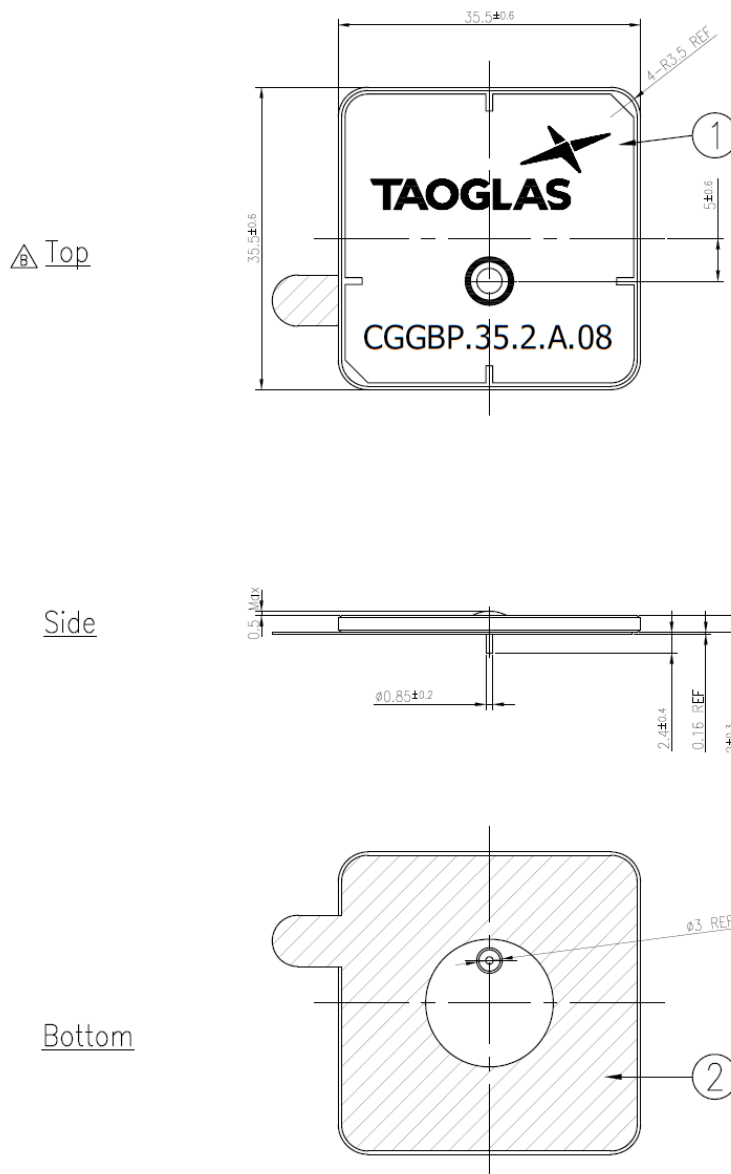

Note:
1. Double sided adhesive area.

	Name	P/N	Material	Finish	QTY
1	Patch	001517D040000A	Ceramic	Clear	1
2	Double sided Adhesive	001517D040000A	NITTO 5000NS	White Liner	1

5.2 Adhesive Thickness

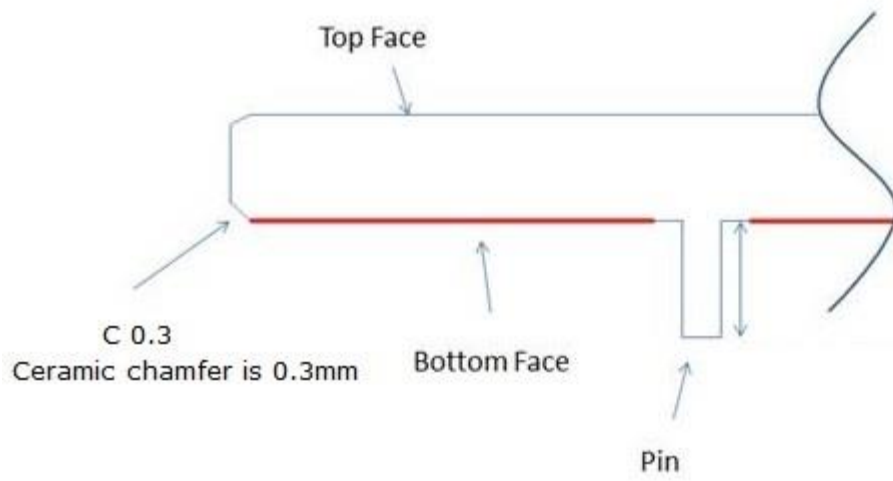

Red Line shows the adhesive without Liner - thickness 0.08~0.1mm

6. Antenna Integration Guide



6.1 Schematic Symbol and Pin Definition

The circuit symbol for the antenna is shown below. The antenna has 1 pin as indicated below.

Pin	Description
1	RF Feed

TAOGLAS_CGGBP.35.2.A.08
ANT1

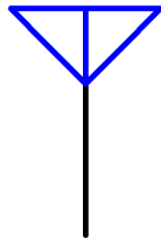

6.2 Antenna Integration

The antenna should be placed at the center of the ground plane with a length and width of 70mm. Maintaining a square symmetric ground plane shape and symmetric environment around the antenna is critical to maintaining the excellent axial ratio and phase center performance shown in this datasheet.



Top Side w/ Solder Mask



Top Side w/o Solder Mask

6.3 PCB Layout

The footprint and clearance on the PCB must comply with the antenna specification. The PCB layout shown in the diagram below demonstrates the antenna footprint.

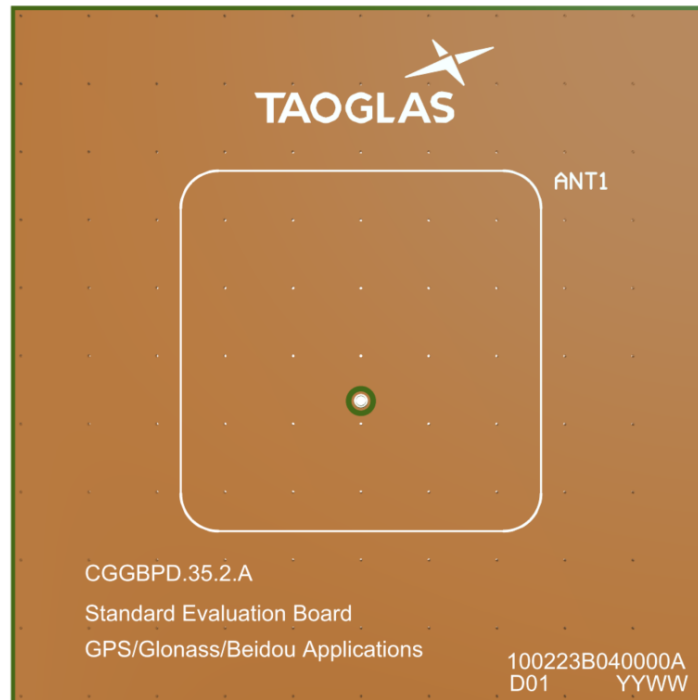

Topside

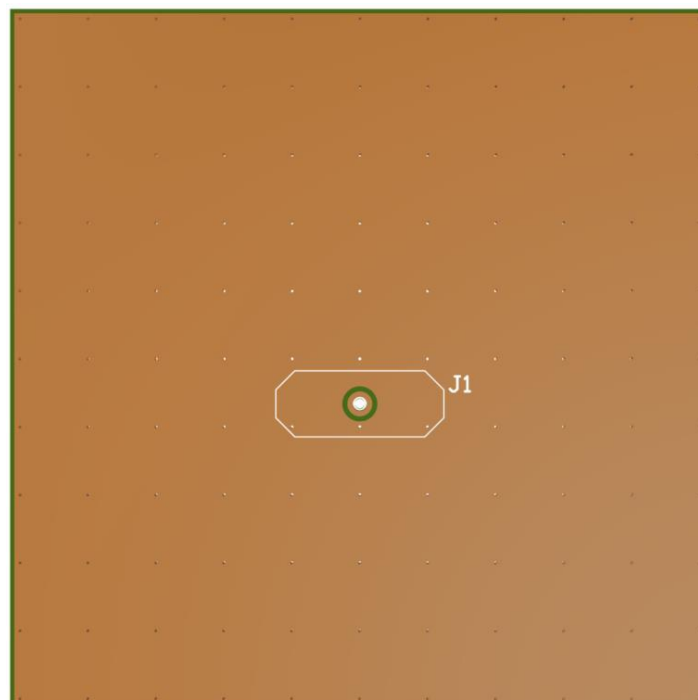

Bottom Side

6.5 Evaluation Board

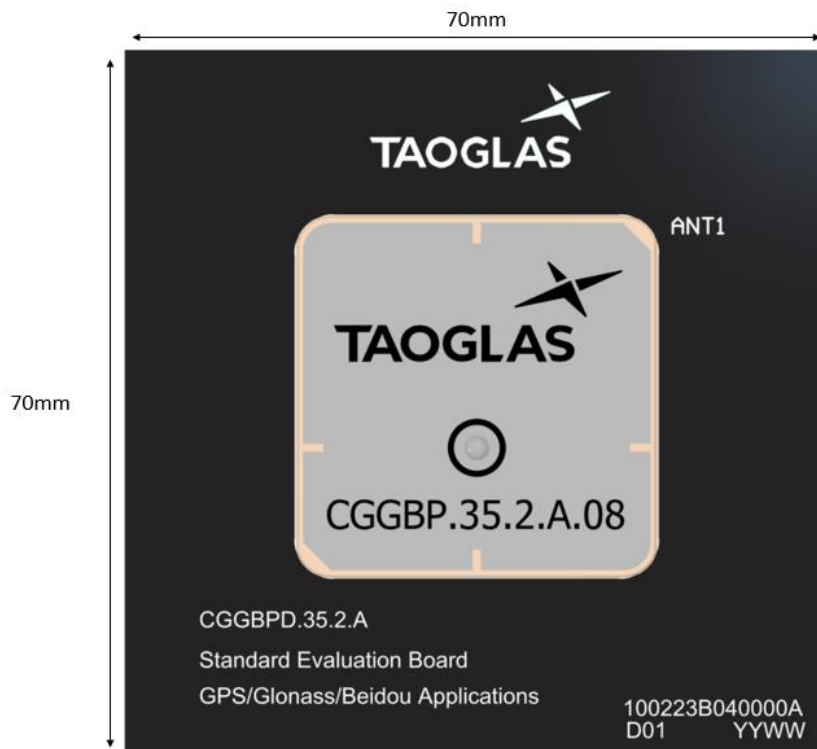

Topside

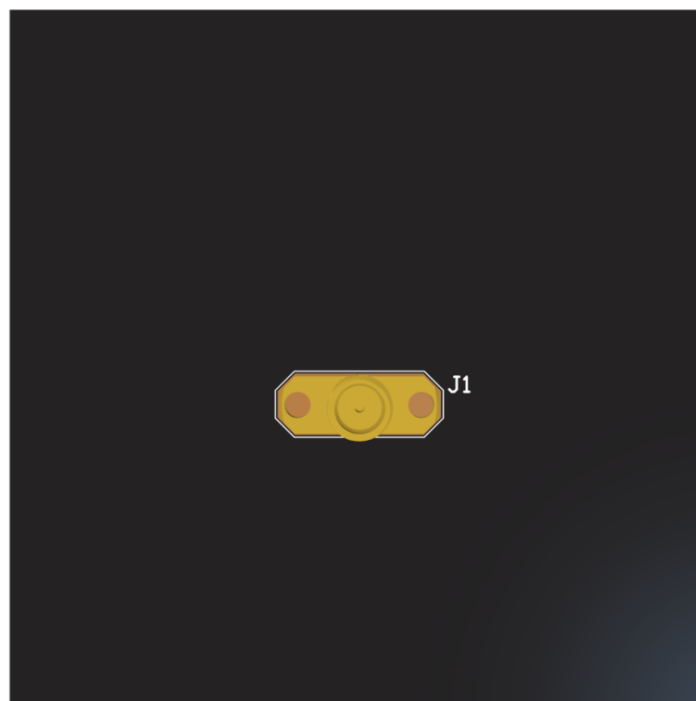

Bottom Side

7. Evaluation Board Mechanical Drawing (unit: mm)

7.1 Evaluation Board Drawing

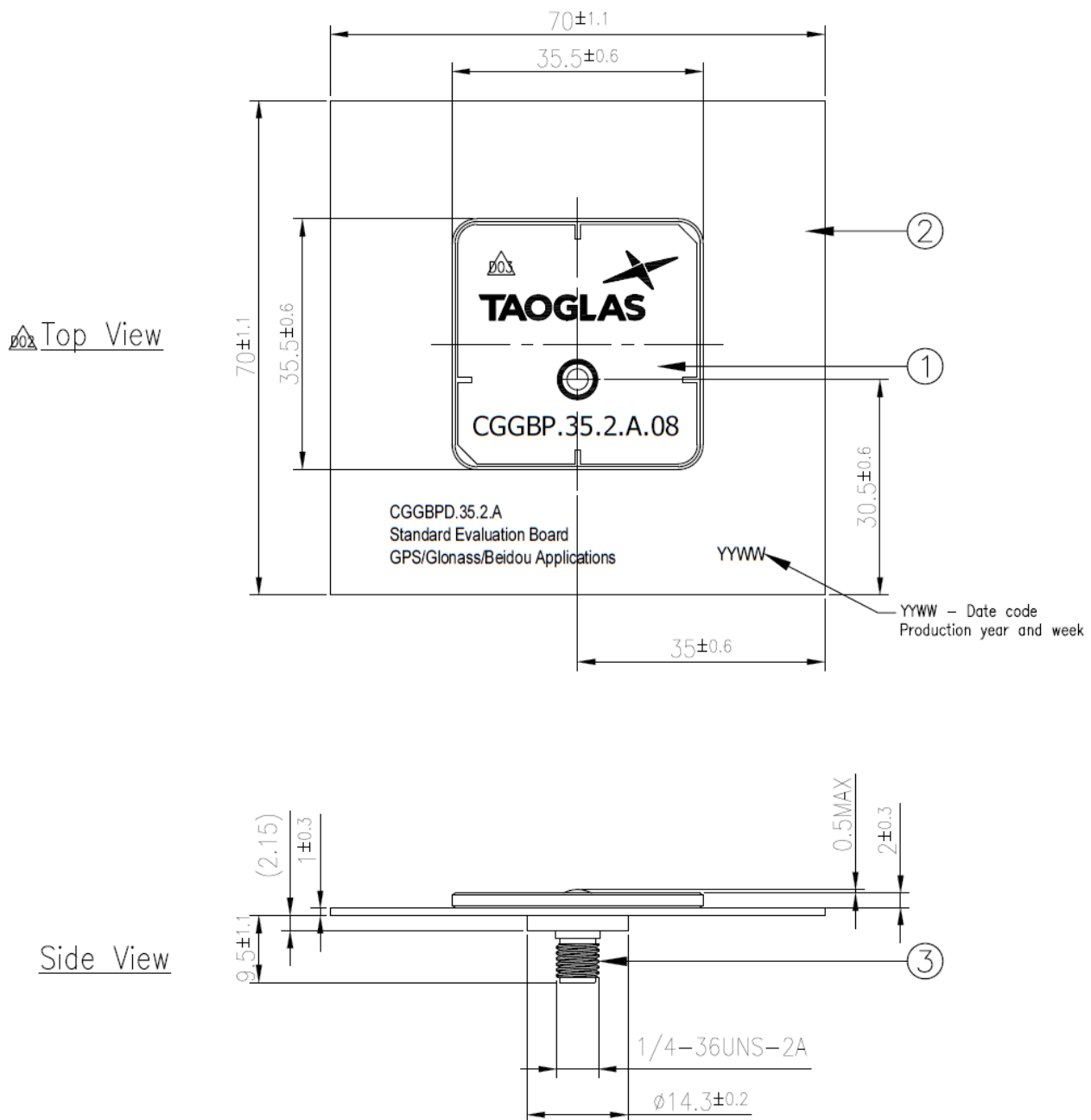

NOTES:

- 1.All material must be RoHS compliant.
- 2.Open/short QC, VSWR required.

	Name	P/N	Material	Finish	QTY
1	Patch	001517D040000A	Ceramic	Clear	1
2	Ground-Plane	000517D010000A	Composite 1.0t	Black	1
3	SMA(F) ST	200417D000000A	Brass	Au Plated	1

8. PCB Footprint Recommendation

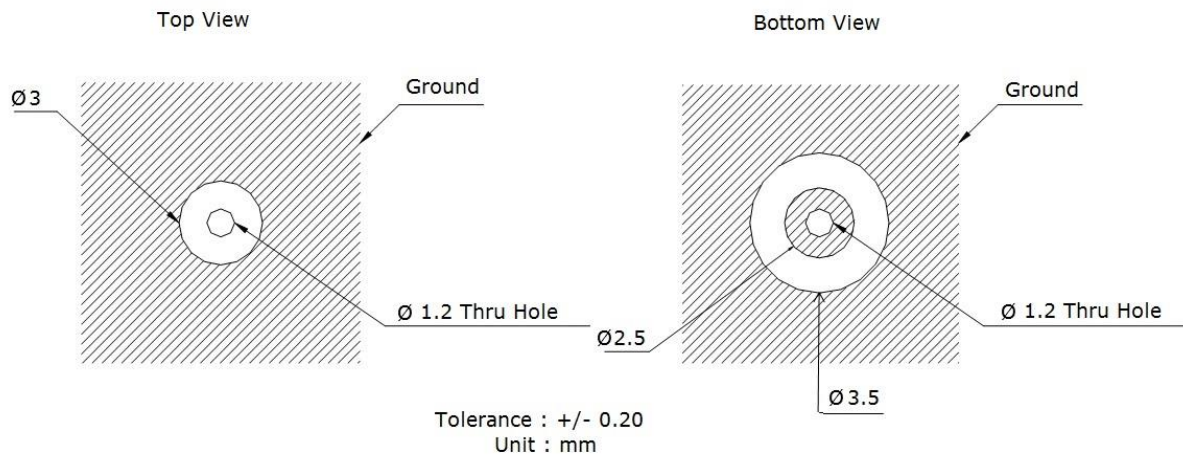

9. Packaging

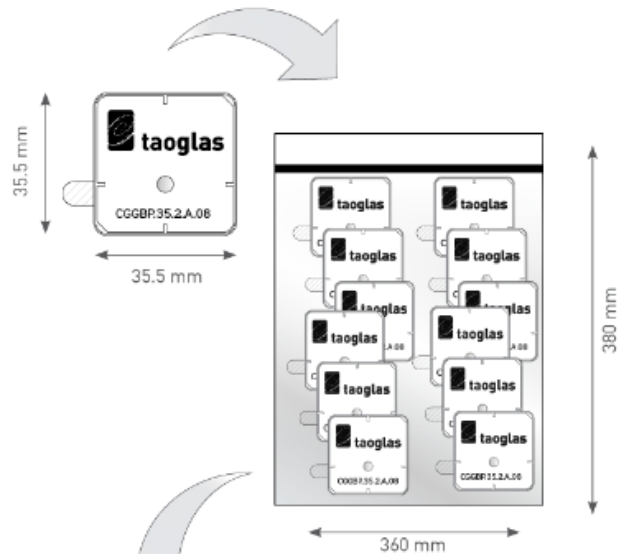

100 pcs CGGBP.35.2.A.08 per PE Bag
 Bag Dimensions - 360 x 380mm
 Weight - 934.5g

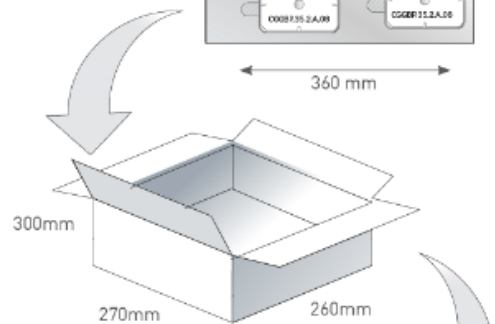

400 pcs CGGBP.35.2.A.08 per Inner Carton
 Inner Carton Dimensions - 270*260*300mm
 Weight - 4.49kg

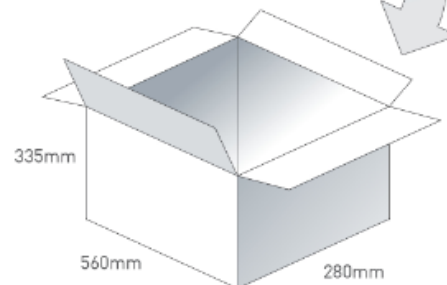

800 pcs CGGBP.35.2.A.08 per Carton
 Carton Dimensions - 560*280*335mm
 Weight - 8.1kg

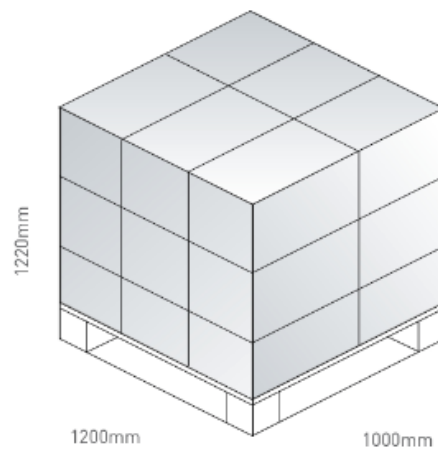

Pallet Dimensions 1200*1000*1220mm
 18 Cartons per Pallet
 6 Cartons per layer
 3 Layers

Changelog for the datasheet

SPE-15-8-010 – CGGBP.35.3.A.02

Revision: D (Current Version)

Date:	2024-05-10
Changes:	Updated GNSS Frequency Bands table
Changes Made by:	Cesar Sousa

Previous Revisions

Revision: C

Date:	2023-03-23
Changes:	Integration Guide Added
Changes Made by:	Cesar Sousa

Revision: B

Date:	2018-12-18
Changes:	Updated Data
Changes Made by:	Jack Conroy

Revision: A (Original First Release)

Date:	2017-07-18
Notes:	Initial Datasheet Release
Author:	Jack Conroy



www.taoglas.com



Looking for pricing, stock, or lifecycle information?

Click below to explore more details on WIN SOURCE:

- ⊖ [View CGGBP.35.2.A.08](#) on WIN SOURCE
- ⊖ [Taoglas Limited](#) Information

Optimize Your Supply Chain with WIN SOURCE Solutions

- ✓ Global Sourcing Solution
- ✓ Obsolete Management
- ✓ Cost Control Management
- ✓ Shortage Management
- ✓ Alternative Solution
- ✓ Excess Inventory Management