



**THE DATASHEET OF
PI6CB33402ZHIEX-13R**



PI6CB33402

Very Low Power 4-Output PCIe Clock Buffer With On-Chip Termination

Description

The DIODES PI6CB33402 is a 4-output very low power PCIe® Gen 1/Gen 2/Gen 3/Gen 4/Gen 5 clock buffer. It takes a reference input to fanout four 100MHz low power differential HCSL outputs with on-chip terminations. The on-chip termination can save 16 external resistors and make layout easier. Individual OE pin for each output provides easier power management.

It uses Diodes proprietary PLL design to achieve very low jitter that meets PCIe Gen 1/Gen 2/Gen 3/Gen 4/Gen 5 requirements. Other than PCIe 100MHz support, this device also support Ethernet application with 50MHz, 125MHz and 133.33MHz via SMBus. It provides various options such as different slew rate and amplitude through SMBUS so that users can configure the device easily to get the optimized performance for their individual boards.

Block Diagram

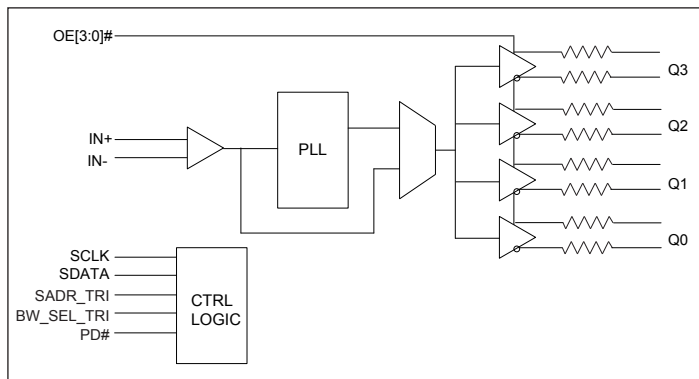

Features

- 3.3V Supply Voltage
- HCSL Input: 100MHz, also Support 50MHz, 125MHz or 133.33MHz via SMBus
- 4 Differential Low Power HCSL Outputs with On-Chip Termination
- Default $Z_{OUT} = 85\Omega$
- Spread Spectrum Tolerant
- Individual Output Enable
- Programmable Slew Rate and Output Amplitude for each Output
- Differential Outputs Blocked Until PLL is Locked
- Strapping Pins or SMBus for Configuration
- Differential Output-to-Output Skew <50ps
- Very Low Jitter Outputs
 - Differential Cycle-to-Cycle Jitter <50ps
 - PCIe Gen 1/Gen 2/Gen3 /Gen 4/Gen 5 CC Compliant
 - PCIe Gen 2 and 3 SRiS and SRnS Compliant
- Totally Lead-Free & Fully RoHS Compliant (Notes 1 & 2)
- Halogen and Antimony Free. "Green" Device (Note 3)
- For automotive applications requiring specific change control (i.e. parts qualified to AEC-Q100/101/104/200, PPAP capable, and manufactured in IATF 16949 certified facilities), please [contact us](https://www.diodes.com/quality/product-definitions/) or your local Diodes representative.
- Packaging (Pb-free & Green):
 - 32-lead 5x5mm TQFN

Notes:

1. No purposely added lead. Fully EU Directive 2002/95/EC (RoHS), 2011/65/EU (RoHS 2) & 2015/863/EU (RoHS 3) compliant.
2. See <https://www.diodes.com/quality/lead-free/> for more information about Diodes Incorporated's definitions of Halogen- and Antimony-free, "Green" and Lead-free.
3. Halogen- and Antimony-free "Green" products are defined as those which contain <900ppm bromine, <900ppm chlorine (<1500ppm total Br + Cl) and <1000ppm antimony compounds.

Pin Configuration

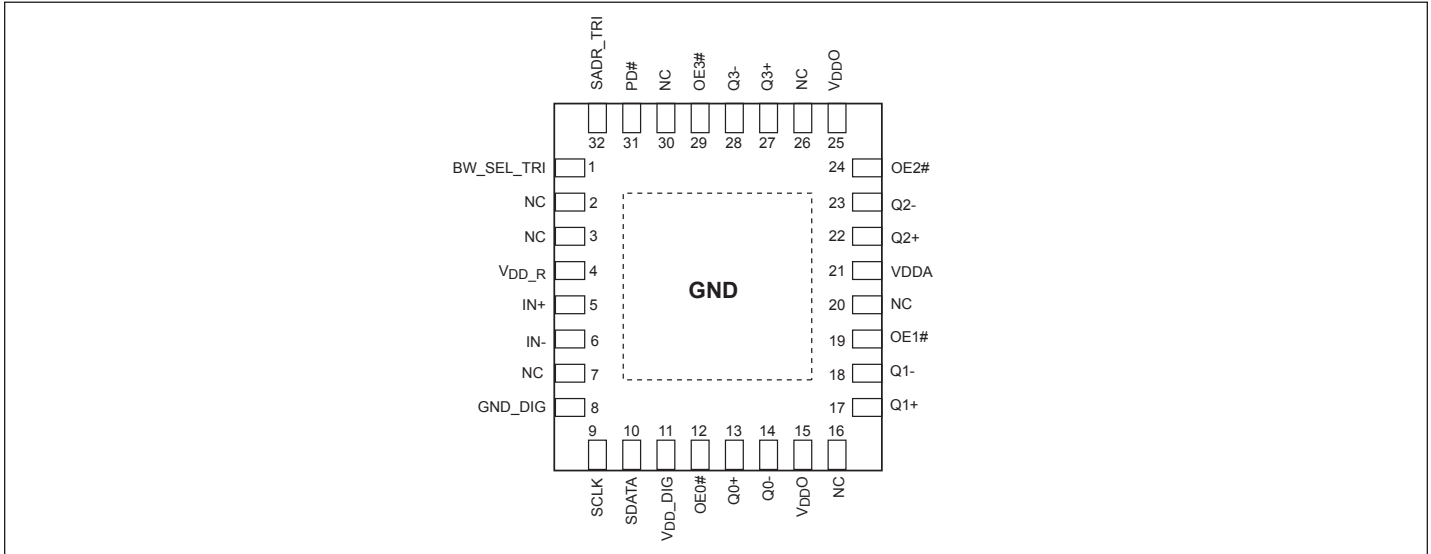

Pin Description

| Pin Number | Pin Name | Type | | Description |
|------------|------------|------------------|-----------|---|
| 1 | BW_SEL_TRI | Input | Tri-level | Latch to select low loop bandwidth, bypass PLL, and high loop bandwidth. This pin has both internal pull-up and pull-down |
| 2 | NC | | | Internal connected for feedback loop. Do not connect this pin |
| 3 | NC | | | Internal connected for feedback loop. Do not connect this pin |
| 4 | VDD_R | Power | | Power supply for input differential buffers |
| 5 | IN+ | Input | | Differential true clock input |
| 6 | IN- | Input | | Differential complementary clock input |
| 7 | NC | | | Do not connect this pin |
| 8 | GND_DIG | Power | | Ground for digital circuitry |
| 9 | SCLK | Input | CMOS | SMBUS clock input, 3.3V tolerant |
| 10 | SDATA | Input/ Output | CMOS | SMBUS Data line, 3.3V tolerant |
| 11 | VDD_DIG | Power | | Power supply for digital circuitry, nominal 3.3V |
| 12 | OE0# | Input | CMOS | Active low input for enabling Q0 pair. This pin has an internal pull-down. 1 =disable outputs, 0 = enable outputs |
| 13 | Q0+ | Output | HCSL | Differential true clock output |
| 14 | Q0- | Output | HCSL | Differential complementary clock output |
| 15, 25 | VDDO | Power | | Power supply for differential outputs |
| 16 | NC | | | Do not connect this pin |
| 17 | Q1+ | Output | HCSL | Differential true clock output |
| 18 | Q1- | Output | HCSL | Differential complementary clock output |

PI6CB33402

| Pin Number | Pin Name | Type | | Description |
|------------|------------------|--------|-----------|---|
| 19 | OE1# | Input | CMOS | Active low input for enabling Q1 pair. This pin has an internal pull-down. 1 =disable outputs, 0 = enable outputs |
| 20 | NC | | | Do not connect this pin |
| 21 | V _{DDA} | Power | | Power supply for analog circuitry |
| 22 | Q2+ | Output | HCSL | Differential true clock output |
| 23 | Q2- | Output | HCSL | Differential complementary clock output |
| 24 | OE2# | Input | CMOS | Active low input for enabling Q2 pair. This pin has an internal pull-down. 1 =disable outputs, 0 = enable outputs |
| 26 | NC | | | Do not connect this pin |
| 27 | Q3+ | Output | HCSL | Differential true clock output |
| 28 | Q3- | Output | HCSL | Differential complementary clock output |
| 29 | OE3# | Input | CMOS | Active low input for enabling Q3 pair. This pin has an internal pull-down. 1 =disable outputs, 0 = enable outputs |
| 30 | NC | | | Do not connect this pin |
| 31 | PD# | Input | CMOS | Input notifies device to sample latched inputs and start up on first high assertion. Low enters Power Down Mode, subsequent high assertions exit Power Down Mode. This pin has internal pull-up resistor. |
| 32 | SADR_TRI | Input | Tri-level | Latch to select SMBus Address. This pin has an internal pull-down |
| | EPAD | Power | | Connect to Ground |

SMBus Address Selection Table

| | SADR | Address | +Read/Write Bit |
|---|------|---------|-----------------|
| State of SADR on first application of PD# | 0 | 1101011 | X |
| | M | 1101100 | X |
| | 1 | 1101101 | X |

Power Management Table

| PD# | IN | SMBus OE bit | OEn# | Qn+ | Qn- | PLL Status |
|-----|---------|--------------|------|--------------------|--------------------|-------------------|
| 0 | X | X | X | Low ⁽²⁾ | Low ⁽²⁾ | Off |
| 1 | Running | 0 | X | Low ⁽²⁾ | Low ⁽²⁾ | On ⁽¹⁾ |
| 1 | Running | 1 | 0 | Running | Running | On ⁽¹⁾ |
| 1 | Running | 1 | 1 | Low ⁽²⁾ | Low ⁽²⁾ | On ⁽¹⁾ |

Note:

1. If PLL Bypass mode is selected, the PLL will be off and outputs will be running.
2. The output state is set by B11[1:0] (Low/Low default)

PLL Operating Mode Select Table

| BW_SEL_TRI | Operating Mode | Byte1 [7:6] Readback | Byte1 [4:3] Control |
|------------|-------------------------|----------------------|---------------------|
| 0 | PLL with low Bandwidth | 00 | 00 |
| M | PLL Bypass | 01 | 01 |
| 1 | PLL with high Bandwidth | 11 | 11 |

Frequency Select Table

| Freq. Select Byte 3 [4:3] | IN (MHz) | Qn (MHz) |
|---------------------------|----------|----------|
| 00 (default) | 100 | 100 |
| 01 | 50 | 50 |
| 10 | 125 | 125 |
| 11 | 133.33 | 133.33 |

Maximum Ratings

(Above which useful life may be impaired. For user guidelines, not tested.)

| | |
|---|---|
| Storage Temperature..... | -65°C to +150°C |
| Supply Voltage to Ground Potential, V _{DDXX} | -0.5V to +4.6V |
| Input Voltage | -0.5V to V _{DD} +0.5V, not exceed 4.6V |
| SMBus, Input High Voltage | 3.6V |
| ESD Protection (HBM) | 2000 V |
| Junction Temperature | 125°C max |

Note:

Stresses greater than those listed under MAXIMUM RATINGS may cause permanent damage to the device. This is a stress rating only and functional operation of the device at these or any other conditions above those indicated in the operational sections of this specification is not implied. Exposure to absolute maximum rating conditions for extended periods may affect reliability.

Operating Conditions

Temperature = T_A; Supply voltages per normal operation conditions; See test circuits for the load conditions

| Symbol | Parameters | Conditions | Min. | Typ. | Max. | Units |
|--|--|---|-------|------|-------|-------|
| V _{DDO} , V _{DDA} , V _{DD_R} , V _{DD_DIG} | Power Supply Voltage | | 3.135 | 3.3 | 3.465 | V |
| I _{DDA} | Analog Power Supply Current | V _{DDA} , PLL mode, All outputs active @100MHz | | 21 | 25 | mA |
| I _{DD_DIG} | Supply Current for V _{DD_DIG} | V _{DD_DIG} , All outputs active @100MHz | | 0.1 | 1 | mA |
| I _{DDO_R} | Power Supply Current for Outputs ⁽²⁾ | V _{DDO} , V _{DD_R} , PLL mode, All outputs active @100MHz | | 48 | 54 | mA |
| I _{DDA_PD} | Analog Power Supply Power Down ⁽¹⁾ Current | V _{DDA} , PLL mode, All outputs LOW/LOW | | 0.5 | 1 | mA |
| I _{DD_DIG_PD} | Power Supply Power Down ⁽¹⁾ Current for V _{DD_DIG} | V _{DD_DIG} , All outputs LOW/LOW | | 0.1 | 1 | mA |
| I _{DDO_R_PD} | Power Supply Current Power Down ⁽¹⁾ for Inputs and Outputs | V _{DDO} , V _{DD_R} All outputs LOW/LOW | | 1 | 2 | mA |
| T _A | Ambient Temperature | Industrial grade | -40 | | 85 | °C |

Note:

1. Input clock is not running.
2. Outputs drive 5 inch trace.

Input Electrical Characteristics

| Symbol | Parameters | Conditions | Min. | Typ. | Max. | Units |
|------------------|-------------------------------|------------|------|------|------|-------|
| R _{pu} | Internal pull up resistance | | | 120 | | KW |
| R _{dn} | Internal pull down resistance | | | 120 | | KW |
| L _{PIN} | Pin inductance | | | | 7 | nH |

SMBus Electrical Characteristics

Temperature = T_A; Supply voltages per normal operation conditions; See test circuits for the load conditions

| Symbol | Parameters | Conditions | Min. | Typ. | Max. | Units |
|----------------------|---------------------------|--|----------------------------|------|------|-------|
| V _{DDSMB} | Nominal bus voltage | | 2.7 | | 3.6 | V |
| V _{IHSMB} | SMBus Input High Voltage | SMBus, V _{DDSMB} = 3.3V | 2.1 | | 3.6 | V |
| | | SMBus, V _{DDSMB} < 3.3V | 0.65 V _{DDSMB} | | | |
| V _{ILSMB} | SMBus Input Low Voltage | SMBus, V _{DDSMB} = 3.3V | | | 0.8 | V |
| | | SMBus, V _{DDSMB} < 3.3V | | | 0.8 | |
| I _{SMBSINK} | SMBus sink current | SMBus, at V _{OLSMB} | 4 | | | mA |
| V _{OLSMB} | SMBus Output Low Voltage | SMBus, at I _{SMBSINK} | | | 0.4 | V |
| f _{MAXSMB} | SMBus operating frequency | Maximum frequency | | | 500 | kHz |
| t _{RMSB} | SMBus rise time | (Max V _{IL} - 0.15) to (Min V _{IH} + 0.15) | | | 1000 | ns |
| t _{FMSB} | SMBus fall time | (Min V _{IH} + 0.15) to (Max V _{IL} - 0.15) | | | 300 | ns |

LVC MOS DC Electrical Characteristics

Temperature = T_A; Supply voltages per normal operation conditions; See test circuits for the load conditions

| Symbol | Parameters | Conditions | Min. | Typ. | Max. | Units |
|-----------------|--------------------|--|-------------------------|--------------------|-------------------------|-------|
| V _{IH} | Input High Voltage | Single-ended inputs, except SMBus | 0.75 V _{DD} | | V _{DD} +0.3 | V |
| V _{IM} | Input Mid Voltage | SADR_TRI, BW_SEL_TRI | 0.4V _{DD} | 0.5V _{DD} | 0.6V _{DD} | V |
| V _{IL} | Input Low Voltage | Single-ended inputs, except SMBus | -0.3 | | 0.25 V _{DD} | V |
| I _{IH} | Input High Current | Single-ended inputs, V _{IN} = V _{DD} | | | 5 | mA |
| I _{IL} | Input Low Current | Single-ended inputs, V _{IN} = 0V | -5 | | | μA |
| I _{IH} | Input High Current | Single-ended inputs with pull up / pull down resistor, V _{IN} = V _{DD} | | | 50 | mA |
| I _{IL} | Input Low Current | Single-ended inputs with pull up / pull down resistor, V _{IN} = 0V | -50 | | | μA |
| C _{IN} | Input Capacitance | | 1.5 | | 5 | pF |

LVCMOS AC Electrical Characteristics

Temperature = T_A; Supply voltages per normal operation conditions; See test circuits for the load conditions

| Symbol | Parameters | Conditions | Min. | Typ. | Max. | Units |
|--------------------|-----------------------|---|------|------|------|--------|
| t _{OELAT} | Output enable latency | Q start after OE# assertion Q stop after OE# deassertion | 1 | | 3 | clocks |
| t _{PDLAT} | PD# de-assertion | Differential outputs enable after PD# de-assertion | | 20 | 300 | us |

HCSL Input Characteristics⁽¹⁾

Temperature = T_A; Supply voltages per normal operation conditions; See test circuits for the load conditions

| Symbol | Parameters | Conditions | Min. | Typ. | Max. | Units |
|-----------------------------|---|---|--------|--------|--------|-------|
| V _{IHDIF} | Diff. Input High Voltage ⁽³⁾ | IN+, IN-, single-end measurement | 600 | 800 | 1150 | mV |
| V _{ILDIF} | Diff. Input Low Voltage ⁽³⁾ | IN+, IN-, single-end measurement | -300 | 0 | 300 | mV |
| V _{COM} | Diff. Input Common Mode Voltage | | 150 | | 900 | mV |
| V _{SWING} | Diff. Input Swing Voltage | Peak to peak value (V _{IHDIF} - V _{ILDIF}) | 300 | | 2900 | mV |
| f _{INBP} | Input Frequency | PLL Bypass mode | 1 | | 200 | MHz |
| f _{IN100} | Input Frequency | 100MHz PLL | 99.9 | 100 | 100.1 | MHz |
| f _{IN133} | Input Frequency | 133MHz PLL | 133.2 | 133.33 | 133.46 | MHz |
| f _{IN125} | Input Frequency | 125MHz PLL | 124.87 | 125 | 125.12 | MHz |
| f _{IN50} | Input Frequency | 50MHz PLL | 49.95 | 50 | 50.05 | MHz |
| f _{MODI-PCIE} | Input SS Modulation Freq. PCIe | Allowable frequency for PCIe applications (Triangular Modulation) | 30 | | 33 | kHz |
| f _{MODIN-non-PCIE} | Input SS Modulation Freq. non-PCIE | Allowable frequency for non-PCIe applications (Triangular Modulation) | 0 | | 46 | kHz |
| t _{STAB} | Clock stabilization | From V _{DD} Power-Up and after input clock stabilization or de-assertion of PD# to 1st clock | | 0.75 | 1.0 | ms |
| t _{RF} | Diff. Input Slew Rate ⁽²⁾ | Measured differentially | 0.4 | | | V/ns |
| I _{IN} | Diff. Input Leakage Current | V _{IN} = V _{DD} , V _{IN} = GND | -5 | 0.01 | 5 | uA |
| t _{DC} | Diff. Input Duty Cycle | Measured differentially | 45 | | 55 | % |
| t _{jC-c} | Diff. Input Cycle to cycle jitter | Measured differentially | | | 125 | ps |

Note:

- Guaranteed by design and characterization, not 100% tested in production
- Slew rate measured through +/-75mV window centered around differential zero
- The device can be driven by a single-ended clock by driving the true clock and biasing the complement clock input to the V_{bias}, where V_{bias} is (V_{IH}-V_{IL})/2

HCSL Output Characteristics

Temperature = T_A; Supply voltages per normal operation conditions; See test circuits for the load conditions

| Symbol | Parameters | Condition | Min. | Typ. | Max. | Units |
|-------------------|---|---|------|------|------|-------|
| V _{OH} | Output Voltage High ⁽¹⁾ | Statistical measurement on single-ended signal using oscilloscope math function | 660 | 784 | 850 | mV |
| V _{OL} | Output Voltage Low ⁽¹⁾ | | -150 | | 150 | mV |
| V _{OMAX} | Output Voltage Maximum ⁽¹⁾ | Measurement on single ended signal using absolute value | | 816 | 1150 | mV |
| V _{OMIN} | Output Voltage Minimum ⁽¹⁾ | | -300 | -42 | | mV |
| V _{OC} | Output Cross Voltage ^(1,2,4) | | 250 | 430 | 550 | mV |
| DV _{OC} | V _{OC} Magnitude Change ^(1,2,5) | | | 12 | 140 | mV |

Note:

- At default SMBUS amplitude settings
- Guaranteed by design and characterization, not 100% tested in production
- Measured from differential waveform
- This one is defined as voltage where Q+ = Q- measured on a component test board and only applied to the differential rising edge
- The total variation of all V_{cross} measurements in any particular system. This is a subset of V_{cross_min/max} allowed.

HCSL Output AC Characteristics

Temperature = T_A; Supply voltages per normal operation conditions; See test circuits for the load conditions

| Symbol | Parameters | Condition | Min. | Typ. | Max. | Units |
|---------------------|--|--|------|------|--------|-------|
| f _{OUT} | Output Frequency | | 50 | 100 | 133.33 | MHz |
| BW | PLL bandwidth ^(1,8) | -3dB point in High Bandwidth Mode | 1.3 | 3.2 | 3.6 | MHz |
| | | -3dB point in Low Bandwidth Mode | 0.7 | 1.7 | 1.9 | MHz |
| t _{jpeak} | PLL Jitter Peaking | Peak pass band gain | | 0.8 | 2 | dB |
| t _{RF} | Slew rate ^(1,2,3) | Scope averaging on fast setting | 2.5 | 3.2 | 4.0 | V/ns |
| | | Scope averaging on slow setting | 2.2 | 3.0 | 3.7 | V/ns |
| D _{tRF} | Slew rate matching ^(1,2,4) | Scope averaging on | | 7 | 15 | % |
| t _{SKEW} | Output Skew ^(1,2) | Averaging on, V _T = 50% | | 21 | 50 | ps |
| t _{PDELAY} | Propagation delay | PLL Bypass mode, V _T = 50% | 2000 | 2500 | 3000 | ps |
| | | PLL mode, V _T = 50% | -200 | 90 | 200 | ps |
| t _{DC} | Duty Cycle ^(1,2) | Measured differentially, PLL Mode | 45 | 50 | 55 | % |
| t _{DCCD} | Duty Cycle Distortion ^(1,7) | Measured differentially, PLL Bypass Mode at 100MHz | -3.5 | 0 | 3.5 | % |
| t _{DCD} | Duty Cycle Distortion ^(1,7) | Measured differentially, SE input, PLL Bypass Mode at 100MHz | -10 | 0 | 10 | % |
| t _{j-c-c} | Cycle to cycle jitter ^(1,2) | PLL mode | | 14 | 50 | ps |
| | | Additive jitter, Bypass mode | | 0.1 | 1 | ps |

HCSSL Output AC Characteristics (jitter)

| Symbol | Parameters | Condition | Min. | Typ. | Max. | Spec Limit | Units |
|------------------------|--|---|------|------|------|------------|---------|
| t _{JPHASEPLL} | Integrated phase jitter PLL mode (RMS) ^(1,5) | PCIe Gen 1 ⁽⁶⁾ | | 25 | 35 | 86 | ps(p-p) |
| | | PCIe Gen 2 Low Band, 10kHz < f < 1.5MHz | | 0.6 | 0.8 | 3 | ps |
| | | PCIe Gen 2 High Band, 1.5MHz < f < Nyquist (50MHz) | | 0.7 | 1.2 | 3.1 | ps |
| | | PCIe Gen 3 (PLL BW of 2-4 or 2-5MHz, CDR = 10MHz) | | 0.25 | 0.4 | 1 | ps |
| | | PCIe Gen 4 (PLL BW of 2-4 or 2-5MHz, CDR = 10MHz) | | 0.25 | 0.4 | 0.5 | ps |
| | | PCIe Gen 5 (PLL BW of 500k to 1.8MHz. CDR = 20MHz) ⁽¹¹⁾ | | 0.07 | 0.12 | 0.15 | ps |
| | | 125MHz, 1.5MHz to 20MHz, -20dB/decade Rollover < 1.5MHz, -40dB/decade rolloff > 10MHz | | 0.15 | 0.3 | | ps |
| | | 133.33MHz | | 0.15 | 0.3 | | ps |
| t _{JPHASEA} | Additive Integrated phase jitter (RMS) ^(1,5,10) | PCIe Gen 1 | | 0.01 | 0.05 | | ps(p-p) |
| | | PCIe Gen 2 Low Band, 10kHz < f < 1.5MHz | | 0.01 | 0.05 | | ps |
| | | PCIe Gen 2 High Band, 1.5MHz < f < Nyquist (50MHz) | | 0.01 | 0.05 | | ps |
| | | PCIe Gen 3 (PLL BW of 2-4 or 2-5MHz, CDR = 10MHz) | | 0.01 | 0.05 | | ps |
| | | PCIe Gen 4 (PLL BW of 2-4 or 2-5MHz, CDR = 10MHz) | | 0.01 | 0.05 | | ps |
| | | PCIe Gen 5 (PLL BW of 500k to 1.8MHz. CDR = 20MHz) ⁽¹¹⁾ | | 0.01 | 0.05 | | ps |
| | | 125MHz, 1.5MHz to 20MHz, -20dB/decade Rollover < 1.5MHz, -40dB/decade rolloff > 10MHz | | 0.01 | 0.05 | | ps |
| | | 133.33MHz | | 0.01 | 0.05 | | ps |
| | | 156.25MHz 12k to 20MHz | | 0.01 | 0.05 | | ps |

Note:

1. Guaranteed by design and characterization, not 100% tested in production
2. Measured from differential waveform
3. Slew rate is measured through the V_{swing} voltage range centered around differential 0V, within +/-150mV window
4. Slew rate matching is measured through +/-75mV window centered around differential zero
5. See <http://www.pcisig.com> for complete specs
6. Sample size of at least 100k cycles. This can be extrapolated to 108ps pk-pk @ 1M cycles for a BER of 10⁻¹²
7. Duty cycle distortion is the difference in duty cycle between the output and input clock when the device is operated in the PLL bypass mode
8. The Min and Max values of each BW setting track each other, low BW max will never occur with high BW min
9. Applies to all differential outputs
10. For additive jitter RMS value is calculated by the following equation = SQRT [(total jitter)^{*2} - (input jitter)^{*2}]
11. PCIe Gen 5 v0.9 specification

SMBus Serial Data Interface

PI6CB33402 is a slave only device that supports block read and block write protocol using a single 7-bit address and read/write bit as shown below.

Read and write block transfers can be stopped after any complete byte transfer.

Address Assignment

| A6 | A5 | A4 | A3 | A2 | A1 | A0 | R/W |
|----|----|----|----|-----------------------------------|----|----|-----|
| 1 | 1 | 0 | 1 | See SBMus Address Selection table | | | 1/0 |

Note: SMBus address is latched on SADR pin

How to Write

| 1 bit | 7 bits | 1 bit | 1 bit | 8 bits | 1 bit | 8 bits | 1 bit | 8 bits | 1 bit | | 8 bits | 1 bit | 1 bit |
|-----------|--------|-------|-------|-----------------------------|-------|---------------------|-------|-------------------------|-------|-------|-------------------|-------|----------|
| Start bit | Add. | W(0) | Ack | Beginning Byte location = N | Ack | Data Byte count = X | Ack | Beginning Data Byte (N) | Ack | | Data Byte (N+X-1) | Ack | Stop bit |

How to Read

| 1 bit | 7 bits | 1 bit | 1 bit | 8 bits | 1 bit | 1 bit | 7 bits | 1 bit | 1 bit | 8 bits | 1 bit | 8 bits | 1 bit |
|-----------|---------|-------|-------|-----------------------------|-------|------------------|---------|-------|-------|---------------------|-------|-------------------------|-------|
| Start bit | Address | W(0) | Ack | Beginning Byte location = N | Ack | Repeat Start bit | Address | R(1) | Ack | Data Byte count = X | Ack | Beginning Data Byte (N) | Ack |

| | | | | | | | | | | 8 bits | 1 bit | 1 bit |
|-------|--|--|--|--|--|--|--|--|--|-------------------|-------|----------|
| | | | | | | | | | | Data Byte (N+X-1) | NAck | Stop bit |

Byte 0: Output Enable Register

| Bit | Control Function | Description | Type | Power Up Condition | 0 | 1 |
|-----|------------------|------------------|------|--------------------|--------------|-------------|
| 7 | Reserved | | | 0 | See B11[1:0] | Pin control |
| 6 | Q3_OE | Q3 output enable | RW | 1 | | |
| 5 | Reserved | | | 0 | | |
| 4 | Q2_OE | Q2 output enable | RW | 1 | | |
| 3 | Q1_OE | Q1 output enable | RW | 1 | | |
| 2 | Reserved | | | 0 | | |
| 1 | Q0_OE | Q0 output enable | RW | 1 | | |
| 0 | Reserved | | | 0 | | |

Note:

1. A low on these bits will override the OE# pins and force the differential outputs to the state indicated by B11[1:0] (Low/Low default)

Byte 1: PLL Operating Mode and Output Amplitude Control Register

| Bit | Control Function | Description | Type | Power Up Condition | 0 | 1 |
|-----|------------------|-------------------------------|-------------------|--------------------|---|--------------------------------|
| 7 | PLLMODERB1 | PLL Mode Readback Bit1 | R | Latch | See PLL Operating Mode Table | |
| 6 | PLLMODERB0 | PLL Mode Readback Bit0 | R | Latch | | |
| 5 | PLLMODE_SWCTR | Enable SW control of PLL Mode | RW | 0 | Values in B1[7:6] set PLL Mode | Values in B1[4:3] set PLL Mode |
| 4 | PLLMODE1 | PLL Mode control Bit1 | RW ⁽¹⁾ | 0 | See PLL Operating Mode Table | |
| 3 | PLLMODE0 | PLL Mode control Bit0 | RW ⁽¹⁾ | 0 | | |
| 2 | Reserved | | | 1 | | |
| 1 | Amplitude1 | Control output amplitude | RW | 1 | '00' = 0.6V, '01' = 0.68V, '10' = 0.75V, '11' = 0.85V | |
| 0 | Amplitude0 | | RW | 0 | | |

Note:

1. B1[5] must be set to a 1 for these bits to have any effect on the part

Byte 2: Differential Output Slew Rate Control Register

| Bit | Control Function | Description | Type | Power Up Condition | 0 | 1 |
|-----|------------------|-------------------------|------|--------------------|--------------|--------------|
| 7 | Reserved | | | 1 | | |
| 6 | SLEWRATECTR_Q3 | Control slew rate of Q3 | RW | 1 | Slow setting | Fast setting |
| 5 | Reserved | | | 1 | | |
| 4 | SLEWRATECTR_Q2 | Control slew rate of Q2 | RW | 1 | Slow setting | Fast setting |
| 3 | SLEWRATECTR_Q1 | Control slew rate of Q1 | RW | 1 | Slow setting | Fast setting |
| 2 | Reserved | | | 1 | | |
| 1 | SLEWRATECTR_Q0 | Control slew rate of Q0 | RW | 1 | Slow setting | Fast setting |
| 0 | Reserved | | | 1 | | |

Byte 3: Frequency Select Control Register

| Bit | Control Function | Description | Type | Power Up Condition | 0 | 1 |
|-----|------------------|-------------------------------------|-------------------|--------------------|-----------------------------|----------------------------|
| 7 | Reserved | | | 1 | | |
| 6 | Reserved | | | 1 | | |
| 5 | FREQ_SEL_EN | Enable SW selection of frequency | RW | 0 | SW Freq. selection disabled | SW Freq. selection enabled |
| 4 | FSEL1 | Freq. Select Bit 1 | RW ⁽¹⁾ | 0 | See Frequency Select Table | |
| 3 | FSEL0 | Freq. Select Bit 0 | RW ⁽¹⁾ | 0 | | |
| 2 | Reserved | | | 1 | | |
| 1 | Reserved | | | 1 | | |
| 0 | SLEWRATESEL_FB | Adjust Slew Rate of Feedback signal | RW | 1 | Slow setting | Fast setting |

Note:

1. B3[5] must be set to a 1 for these bits to have any effect on the part

Byte 4: Reserved

| Bit | Control Function | Description | Type | Power Up Condition | 0 | 1 |
|-----|------------------|-------------|------|--------------------|---|---|
| 7:0 | Reserved | | | 1 | | |

PI6CB33402

Byte 5: Revision and Vendor ID Register

| Bit | Control Function | Description | Type | Power Up Condition | 0 | 1 |
|-----|------------------|-------------|------|--------------------|---------------|---|
| 7 | RID3 | Revision ID | R | 0 | rev = 0000 | |
| 6 | RID2 | | R | 0 | | |
| 5 | RID1 | | R | 0 | | |
| 4 | RID0 | | R | 0 | | |
| 3 | PVID3 | Vendor ID | R | 0 | Diodes = 0011 | |
| 2 | PVID2 | | R | 0 | | |
| 1 | PVID1 | | R | 1 | | |
| 0 | PVID0 | | R | 1 | | |

Byte 6: Device Type/Device ID Register

| Bit | Control Function | Description | Type | Power Up Condition | 0 | 1 |
|-----|------------------|-------------|------|--------------------|--|---|
| 7 | DTYPE1 | Device type | RW | 0 | '00' = CG, '01' = ZDB, '10' = Reserve, '11' = ZDB | |
| 6 | DTYPE0 | | RW | 1 | | |
| 5 | DID5 | Device ID | RW | 0 | 000100 binary, 04Hex | |
| 4 | DID4 | | RW | 0 | | |
| 3 | DID3 | | RW | 0 | | |
| 2 | DID2 | | RW | 1 | | |
| 1 | DID1 | | RW | 0 | | |
| 0 | DID0 | | RW | 0 | | |

Byte 7: Reserved

| Bit | Control Function | Description | Type | Power Up Condition | 0 | 1 |
|-----|------------------|-------------|------|--------------------|---|---|
| 7:0 | Reserved | | | 0x08 | | |

Byte 8 and 9: Reserved

| Bit | Control Function | Description | Type | Power Up Condition | 0 | 1 |
|-----|------------------|-------------|------|------------------------|---|---|
| 7:0 | Reserved | | | B8 = 0x36 B9 = 0x00 | | |

PI6CB33402

Byte 10: PD Restore

| Bit | Control Function | Description | Type | Power Up Condition | 0 | 1 |
|-----|------------------|-------------------------------------|------|--------------------|-----------------|----------------|
| 7 | Reserved | | RW | 1 | | |
| 6 | PD Restore | PD Restore to default configuration | RW | 1 | Clear PD Config | Keep PD Config |
| 5:0 | Reserved | | R | 0 | | |

Byte 11: Stop Control

| Bit | Control Function | Description | Type | Power Up Condition | 0 | 1 |
|-----|------------------|--|------|--------------------|----------------|-----------------|
| 7 | FB_imp[1] | Feedback Zout | RW | 0 | 00=Reserved | 10=100 DIF Zout |
| 6 | FB_imp[0] | | RW | 1 | 01=85 DIF Zout | 11 = Reserved |
| 5:2 | Reserved | | | 0 | | |
| 1 | STP1 | True/ Compliment DIF Output Disable Sate | RW | 0 | 00= Low/Low | 10= High/Low |
| 0 | STP0 | | RW | 0 | 01= HiZ/HiZ | 11= Low/High |

Byte 12: Impedance Control

| Bit | Control Function | Description | Type | Power Up Condition | 0 | 1 |
|-----|------------------|-------------|------|--------------------|---|---|
| 7 | Q1_Zout1 | Q1 Zout | RW | 01 | 00 = Reserved 01 = 85Ω 10 = 100Ω 11 = Reserved | |
| 6 | Q1_Zout0 | Q1 Zout | RW | | | |
| 5 | Reserved | | RW | | | |
| 4 | Reserved | | RW | | | |
| 3 | Q0_Zout1 | Q0 Zout | RW | | | |
| 2 | Q0_Zout0 | Q0 Zout | RW | | | |
| 1 | Reserved | | RW | | | |
| 0 | Reserved | | RW | | | |

Byte 13: Impedance Control

| Bit | Control Function | Description | Type | Power Up Condition | 0 | 1 |
|-----|------------------|-------------|------|--------------------|---|---|
| 7 | Reserved | | RW | 01 | 00 = Reserved 01 = 85Ω 10 = 100Ω 11 = Reserved | |
| 6 | Reserved | | RW | | | |
| 5 | Q3_Zout1 | Q3 Zout | RW | | | |
| 4 | Q3_Zout0 | Q3 Zout | RW | | | |
| 3 | Reserved | | RW | | | |
| 2 | Reserved | | RW | | | |
| 1 | Q2_Zout1 | Q2 Zout | RW | | | |
| 0 | Q2_Zout0 | Q2 Zout | RW | | | |

Byte 14: OE Termination Control

| Bit | Control Function | Description | Type | Power Up Condition | 0 | 1 |
|-----|------------------|---------------------|------|--------------------|--------------|--------------------|
| 7 | OE1_term1 | OE1 Pull up or down | RW | 0 | 00=None | 10= Pullup |
| 6 | OE1_term0 | OE1 Pull up or down | RW | 1 | 01= Pulldown | 11=Pullup and Down |
| 5 | Reserved | | RW | 0 | | |
| 4 | Reserved | | RW | 1 | | |
| 3 | OE0_term1 | OE0 Pull up or down | RW | 0 | 00=None | 10= Pullup |
| 2 | OE0_term0 | OE0 Pull up or down | RW | 1 | 01= Pulldown | 11=Pullup and Down |
| 1 | Reserved | | | 0 | | |
| 0 | Reserved | | | 1 | | |

Byte 15: OE Termination Control

| Bit | Control Function | Description | Type | Power Up Condition | 0 | 1 |
|-----|------------------|---------------------|------|--------------------|--------------|--------------------|
| 7 | Reserved | | RW | 0 | | |
| 6 | Reserved | | RW | 1 | | |
| 5 | OE3_term1 | OE3 Pull up or down | RW | 0 | 00=None | 10= Pullup |
| 4 | OE3_term0 | OE3 Pull up or down | RW | 1 | 01= Pulldown | 11=Pullup and Down |
| 3 | Reserved | | | 0 | | |
| 2 | Reserved | | | 1 | | |
| 1 | OE2_term1 | OE2 Pull up or down | RW | 0 | 00=None | 10= Pullup |
| 0 | OE2_term0 | OE2 Pull up or down | RW | 1 | 01= Pulldown | 11=Pullup and Down |

PI6CB33402

Byte 16: Power Good Termination Control

| Bit | Control Function | Description | Type | Power Up Condition | 0 | 1 |
|-----|------------------|--|------|--------------------|--------------|--------------------|
| 7:2 | Reserved | | | 0x09 | | |
| 1 | PWRGD_PD1 | Clock Power Good and Power Down Pull up or Pull down | RW | 1 | 00=None | 10= Pullup |
| 0 | PWRGD_PD0 | | RW | 0 | 01= Pulldown | 11=Pullup and Down |

Byte 17: Reserved

| Bit | Control Function | Description | Type | Power Up Condition | 0 | 1 |
|-----|------------------|-------------|------|--------------------|---|---|
| 7:0 | Reserved | | | 0 | | |

Byte 18: Enable Pin Control

| Bit | Control Function | Description | Type | Power Up Condition | 0 | 1 |
|-----|------------------|-------------------------|------|--------------------|--------------|---------------|
| 7 | Reserved | | RW | 0 | | |
| 6 | OE3_Enable | Sets Enable High or Low | RW | 0 | Enable = Low | Enable = High |
| 5 | Reserved | | | 0 | | |
| 4 | OE2_Enable | Sets Enable High or Low | RW | 0 | Enable = Low | Enable = High |
| 3 | OE1_Enable | Sets Enable High or Low | RW | 0 | Enable = Low | Enable = High |
| 2 | Reserved | | RW | 0 | | |
| 1 | OE0_Enable | Sets Enable High or Low | RW | 0 | Enable = Low | Enable = High |
| 0 | Reserved | | RW | 0 | | |

Byte 19: Power Down Pin Control

| Bit | Control Function | Description | Type | Power Up Condition | 0 | 1 |
|-----|------------------|--|------|--------------------|------------------|-------------------|
| 7:1 | Reserved | | | 0 | | |
| 0 | PWRGD_PD | PWRGD_PD Active via Pull up or Pull down | RW | 0 | Power Down = Low | Power Down = High |

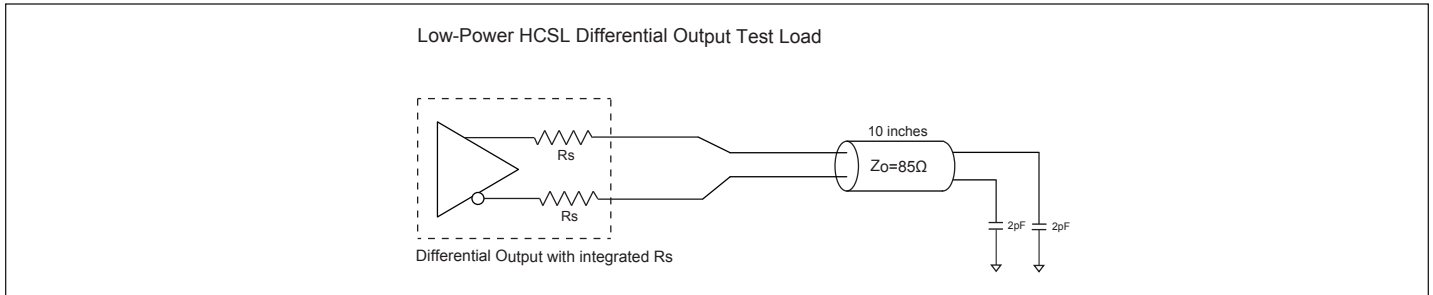

Figure 1. Low Power HCSL Test Circuit

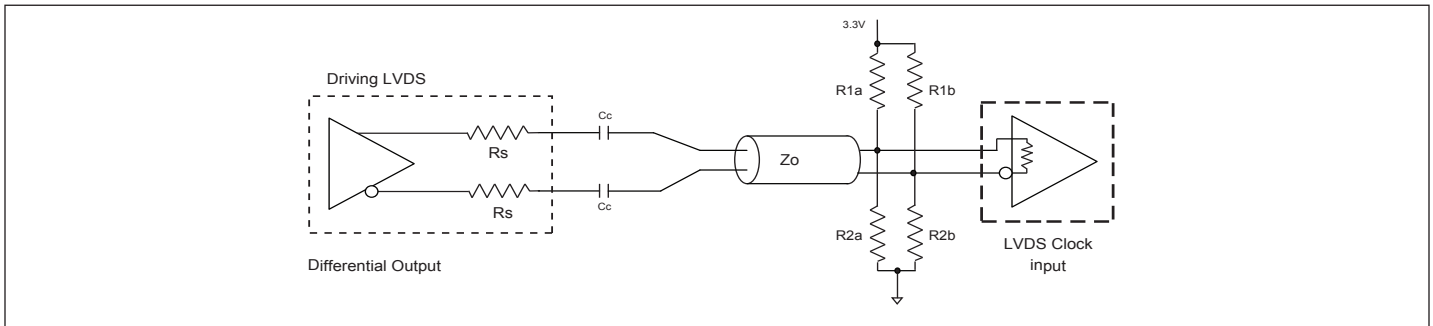

Figure 2. Differential Output Driving LVDS

Alternate Differential Output Terminations ($Z_O = 85\Omega$)

| Component | Receiver with termination | Receiver without termination | Unit |
|-----------------------------------|---------------------------|------------------------------|------|
| R _{1a} , R _{1b} | 10,000 | 130 | Ω |
| R _{2a} , R _{2b} | 5,600 | 64 | Ω |
| C _C | 0.1 | 0.1 | μF |
| V _{CM} | 1.2 | 1.2 | V |

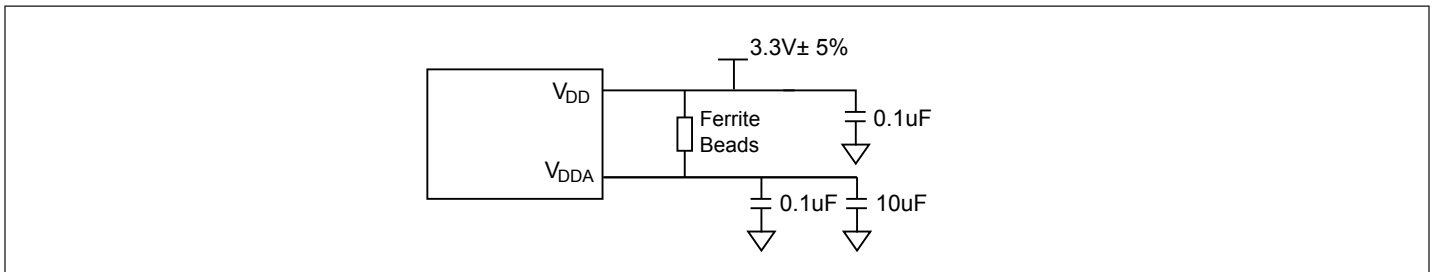

Figure 3. Power Supply Filter

Thermal Characteristics

| Symbol | Parameter | Conditions | Min. | Typ. | Max. | Unit |
|---------------|--|------------|------|------|------|------|
| θ_{JA} | Thermal Resistance Junction to Ambient | Still air | | | 44.7 | °C/W |
| θ_{JC} | Thermal Resistance Junction to Case | | | | 21.7 | °C/W |

PI6CB33402

Part Marking

PI6CB33
402ZHIE
YYWWXX

○

YY: Year
WW: Workweek
1st X: Assembly Code
2nd X: Fab Code

Package Information

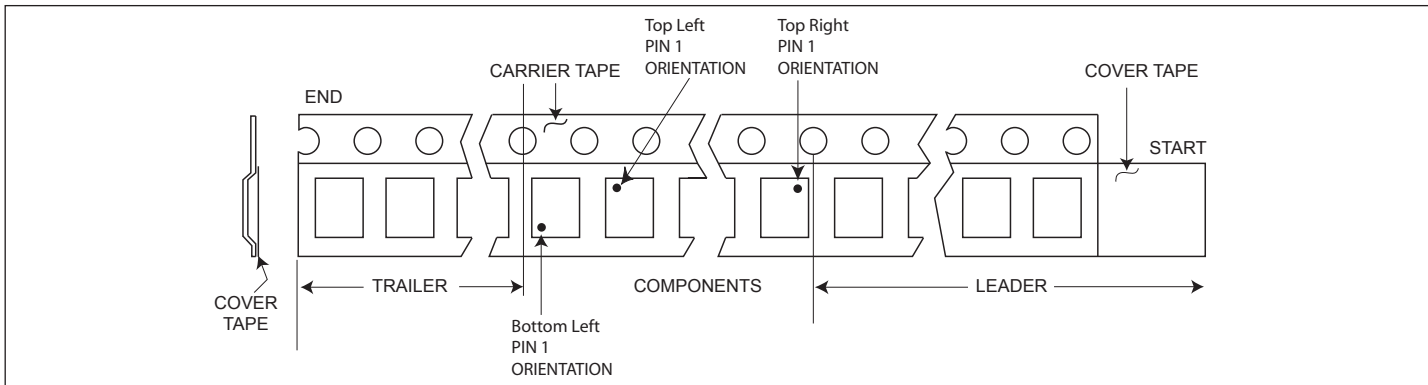

| Suffix | Tape Orientation |
|--------|------------------|
| -13R | |
| -13RA | |

PI6CB33402

Packaging Mechanical

32-WQFN (ZH)

Top View

Bottom View

| SYMBOLS | MIN. | NOM. | MAX. |
|---------|------------|------|------|
| A | 0.70 | 0.75 | 0.80 |
| A1 | 0.00 | 0.02 | 0.05 |
| A3 | 0.203 REF. | | |
| b | 0.18 | 0.25 | 0.30 |
| D | 4.90 | 5.00 | 5.10 |
| E | 4.90 | 5.00 | 5.10 |
| e | 0.50 BSC | | |
| L | 0.35 | 0.40 | 0.45 |
| D2 | 3.15 | 3.25 | 3.35 |
| E2 | 3.15 | 3.25 | 3.35 |

RECOMMENDED LAND PATTERN

| | |
|------------------------------------|--------------------|
| | DATE: 05/25/23 |
| | |
| DESCRIPTION: W-QFN5050-32 | |
| PACKAGE CODE: ZH (ZH32) | |
| DOCUMENT CONTROL #: PD-2070 | REVISION: D |

NOTE :

- ALL DIMENSIONS ARE IN mm. ANGLES IN DEGREES.
- COPLANARITY APPLIES TO THE EXPOSED PAD AS WELL AS THE TERMINALS.
- REFER JEDEC MO-220.
- RECOMMENDED LAND PATTERN IS FOR REFERENCE ONLY.
- THERMAL PAD SOLDERING AREA (MESH STENCIL DESIGN IS RECOMMENDED)

For latest package info.

please check: <http://www.diodes.com/design/support/packaging/pericom-packaging/packaging-mechanicals-and-thermal-characteristics/>

Ordering Information

| Ordering Code | Package Code | Package Description | Pin 1 Location |
|---------------------|--------------|---------------------|------------------|
| PI6CB33402ZHIEX | ZH | W-QFN5050-32 | Top Right Corner |
| PI6CB33402ZHIEX-13R | ZH | W-QFN5050-32 | Top Left Corner |

Notes:

- No purposely added lead. Fully EU Directive 2002/95/EC (RoHS), 2011/65/EU (RoHS 2) & 2015/863/EU (RoHS 3) compliant.
- See <https://www.diodes.com/quality/lead-free/> for more information about Diodes Incorporated's definitions of Halogen- and Antimony-free, "Green" and Lead-free.
- Halogen- and Antimony-free "Green" products are defined as those which contain <900ppm bromine, <900ppm chlorine (<1500ppm total Br + Cl) and <1000ppm antimony compounds.
- E = Pb-free and Green
- X suffix = Tape/Reel
- For packaging details, go to our website at: <https://www.diodes.com/assets/MediaList-Attachments/Diodes-Package-Information.pdf>

IMPORTANT NOTICE

1. DIODES INCORPORATED (Diodes) AND ITS SUBSIDIARIES MAKE NO WARRANTY OF ANY KIND, EXPRESS OR IMPLIED, WITH REGARDS TO ANY INFORMATION CONTAINED IN THIS DOCUMENT, INCLUDING, BUT NOT LIMITED TO, THE IMPLIED WARRANTIES OF MERCHANTABILITY, FITNESS FOR A PARTICULAR PURPOSE OR NON-INFRINGEMENT OF THIRD PARTY INTELLECTUAL PROPERTY RIGHTS (AND THEIR EQUIVALENTS UNDER THE LAWS OF ANY JURISDICTION).

2. The Information contained herein is for informational purpose only and is provided only to illustrate the operation of Diodes' products described herein and application examples. Diodes does not assume any liability arising out of the application or use of this document or any product described herein. This document is intended for skilled and technically trained engineering customers and users who design with Diodes' products. Diodes' products may be used to facilitate safety-related applications; however, in all instances customers and users are responsible for (a) selecting the appropriate Diodes products for their applications, (b) evaluating the suitability of Diodes' products for their intended applications, (c) ensuring their applications, which incorporate Diodes' products, comply the applicable legal and regulatory requirements as well as safety and functional-safety related standards, and (d) ensuring they design with appropriate safeguards (including testing, validation, quality control techniques, redundancy, malfunction prevention, and appropriate treatment for aging degradation) to minimize the risks associated with their applications.

3. Diodes assumes no liability for any application-related information, support, assistance or feedback that may be provided by Diodes from time to time. Any customer or user of this document or products described herein will assume all risks and liabilities associated with such use, and will hold Diodes and all companies whose products are represented herein or on Diodes' websites, harmless against all damages and liabilities.

4. Products described herein may be covered by one or more United States, international or foreign patents and pending patent applications. Product names and markings noted herein may also be covered by one or more United States, international or foreign trademarks and trademark applications. Diodes does not convey any license under any of its intellectual property rights or the rights of any third parties (including third parties whose products and services may be described in this document or on Diodes' website) under this document.

5. Diodes' products are provided subject to Diodes' Standard Terms and Conditions of Sale (<https://www.diodes.com/about/company/terms-and-conditions/terms-and-conditions-of-sales/>) or other applicable terms. This document does not alter or expand the applicable warranties provided by Diodes. Diodes does not warrant or accept any liability whatsoever in respect of any products purchased through unauthorized sales channel.

6. Diodes' products and technology may not be used for or incorporated into any products or systems whose manufacture, use or sale is prohibited under any applicable laws and regulations. Should customers or users use Diodes' products in contravention of any applicable laws or regulations, or for any unintended or unauthorized application, customers and users will (a) be solely responsible for any damages, losses or penalties arising in connection therewith or as a result thereof, and (b) indemnify and hold Diodes and its representatives and agents harmless against any and all claims, damages, expenses, and attorney fees arising out of, directly or indirectly, any claim relating to any noncompliance with the applicable laws and regulations, as well as any unintended or unauthorized application.

7. While efforts have been made to ensure the information contained in this document is accurate, complete and current, it may contain technical inaccuracies, omissions and typographical errors. Diodes does not warrant that information contained in this document is error-free and Diodes is under no obligation to update or otherwise correct this information. Notwithstanding the foregoing, Diodes reserves the right to make modifications, enhancements, improvements, corrections or other changes without further notice to this document and any product described herein. This document is written in English but may be translated into multiple languages for reference. Only the English version of this document is the final and determinative format released by Diodes.

8. Any unauthorized copying, modification, distribution, transmission, display or other use of this document (or any portion hereof) is prohibited. Diodes assumes no responsibility for any losses incurred by the customers or users or any third parties arising from any such unauthorized use.

9. This Notice may be periodically updated with the most recent version available at <https://www.diodes.com/about/company/terms-and-conditions/important-notice>

The Diodes logo is a registered trademark of Diodes Incorporated in the United States and other countries.

All other trademarks are the property of their respective owners.

© 2023 Diodes Incorporated. All Rights Reserved.

www.diodes.com

Looking for pricing, stock, or lifecycle information?

Click below to explore more details on WIN SOURCE:

 [View PI6CB33402ZHIEX-13R on WIN SOURCE](#)

 [Diodes Incorporated Information](#)

Optimize Your Supply Chain with WIN SOURCE Solutions

-  Global Sourcing Solution
-  Obsolete Management
-  Cost Control Management
-  Shortage Management
-  Alternative Solution
-  Excess Inventory Management