



**THE DATASHEET OF
MAX14778ETP+**



Click [here](#) to ask about the production status of specific part numbers.

MAX14778

Dual $\pm 25V$ Above- and Below-the-Rails 4:1 Analog Multiplexer

General Description

The MAX14778 dual 4:1 analog multiplexer supports analog signals up to $\pm 25V$ with a single 3.0 to 5.5V supply. Each multiplexer has separate control inputs to allow independent switching, making the device ideal for multiplexing different communications signals with the same connector pins. Extended ESD protection of $\pm 6kV$ (Human Body Model) enable direct interfacing to cables and connectors.

The MAX14778 features a low 1.5Ω (max) on-resistance and $3m\Omega$ (typ) flatness to maximize signal integrity over the entire common-mode voltage range. Each multiplexer can carry up to 300mA of continuous current through the multiplexer in either direction.

The MAX14778 supports switching of full-speed USB 1.1 signals (12Mbps) and RS-485 data rates of up to 20Mbps.

The MAX14778 is available in a 20-pin (5mm x 5mm) TQFN package and is specified over the $-40^{\circ}C$ to $+125^{\circ}C$ industrial temperature range.

Applications

- RS-485/RS-232/USB 1.1 Multiplexing
- POS Peripherals
- Handheld Industrial Devices
- Communication Systems
- Audio/Data Multiplexing
- Connector Sharing
- Gaming Machines

Ordering Information appears at end of data sheet.

Benefits and Features

- Wide Signal Range Supported from Single-Supply Voltage Eliminates Negative Power Supply
 - $\pm 25V$ Signal Range
 - Single 3.0V to 5.5V Supply
- Two Independent Multiplexers
 - Break-Before-Make Operation
 - 1.5Ω R_{ON} (max)
 - $3m\Omega$ R_{ON} Flatness (typ)
 - 300mA Maximum Current Through Multiplexer
 - 78pF Input Capacitance
 - 75MHz Large-Signal Bandwidth
- 20-Pin TQFN (5mm x 5mm) Package
- Extended ESD Protection on A₋ and B₋ Pins
 - $\pm 6kV$ Human Body Model (HBM)

Functional Diagram

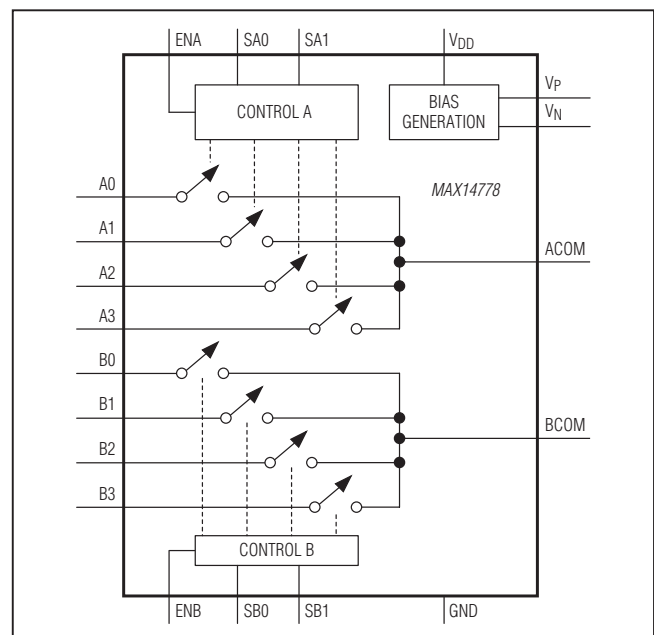

Absolute Maximum Ratings

(All voltages referenced to GND.)

V_{DD}.....-0.3V to +6V
 V_P.....-0.3V to the lesser of +52V and (V_N + 70V)
 V_N..... The lesser of (V_{DD} - 40V) and (V_P - 70V) to +0.3V
 V_P to V_N.....-0.3V to +70V
 ENA, ENB, SA_, SB_.....-0.3V to (V_{DD} + 0.3V)
 A_, ACOM, B_,
 BCOM..(V_N - 0.3V) to the lesser of (V_P + 0.3V) and (V_N + 52V)

Continuous Current Through Switch ±500mA
 Continuous Power Dissipation (T_A = +70°C)
 TQFN (derate 33.3mW/°C above +70°C).....2666.7mW
 Operating Temperature Range..... -40°C to +125°C
 Junction Temperature..... +150°C
 Storage Temperature Range..... -65°C to +150°C
 Lead Temperature (soldering, 10s) +300°C
 Soldering Temperature (reflow)..... +260°C

Stresses beyond those listed under “Absolute Maximum Ratings” may cause permanent damage to the device. These are stress ratings only, and functional operation of the device at these or any other conditions beyond those indicated in the operational sections of the specifications is not implied. Exposure to absolute maximum rating conditions for extended periods may affect device reliability.

Package Information

PACKAGE TYPE: 20 TQFN	
Package Code	T2055+4
Outline Number	21-0140
Land Pattern Number	90-0009
THERMAL RESISTANCE, FOUR-LAYER BOARD	
Junction to Ambient (θ _{JA})	30°C/W
Junction to Case (θ _{JC})	2°C/W

For the latest package outline information and land patterns (footprints), go to www.maximintegrated.com/packages. Note that a “+”, “#”, or “-” in the package code indicates RoHS status only. Package drawings may show a different suffix character, but the drawing pertains to the package regardless of RoHS status.

Package thermal resistances were obtained using the method described in JEDEC specification JESD51-7, using a four-layer board. For detailed information on package thermal considerations, refer to www.maximintegrated.com/thermal-tutorial.

Electrical Characteristics

(V_{DD} = 3.0V to 5.5V, T_A = -40°C to +125°C, unless otherwise noted. Typical values are at V_{DD} = 5V, T_A = +25°C.) (Note 1)

PARAMETER	SYMBOL	CONDITIONS	MIN	TYP	MAX	UNITS
DC CHARACTERISTICS						
Supply Voltage Range	V _{DD}		3.0		5.5	V
Supply Current	I _{DD}	ENA = ENB = high	V _{DD} ≤ V _{DDTH}	4.27	10	mA
			V _{DD} > V _{DDTH}	2.54	6	
		V _{ENA} = V _{ENB} = V _{DD} /2	V _{DD} ≤ V _{DDTH}	4.31	10	
			V _{DD} > V _{DDTH}	2.59	6	
Charge-Pump Threshold	V _{DDTH}	(Note 2)		4.64		V
Analog Signal Range	V _{IN}	Figure 1, switch open or closed	-25		+25	V
Continuous Current Through Switch	I _{COM}		-300		+300	mA
On-Resistance	R _{ON}	Figure 1, I _{COM} = ±300mA, V _{IN} = ±25V		0.84	1.7	Ω
				0.84	1.5	
On-Resistance Flatness	R _{FLAT(ON)}	Figure 1, -25V ≤ V _{IN} ≤ +25V, I _{COM} = ±300mA		3		mΩ
A_, B_ Off-Leakage Current	I _{A(OFF)} , I _{B(OFF)}	Figure 2, V _{IN} = 25V, V _{OUT} = 0V		-250	+250	nA
				-200	+200	
ACOM, BCOM Off-Leakage Current	I _{ACOM(OFF)} , I _{BCOM(OFF)}	Figure 2, V _{OUT} = 15V, V _{IN} = 0V	-1		+1	μA
A_, B_ On-Leakage Current	I _{A(ON)} , I _{B(ON)}	Figure 2, V _{IN} = ±25V, ACOM or BCOM is unconnected	-1		+1	μA
LOGIC INPUTS (ENA, ENB, SA_, SB_)						
Input Logic-Low Voltage	V _{IL}		V _{DD} = 5.5V		0.8	V
			V _{DD} = 4.5V		0.8	
			V _{DD} = 3.6V		0.7	
			V _{DD} = 3.0V		0.7	
Input Logic-High Voltage	V _{IH}		V _{DD} = 5.5V	2.2		V
			V _{DD} = 4.5V	2.1		
			V _{DD} = 3.6V	1.9		
			V _{DD} = 3.0V	1.8		
		-40°C to 85°C	V _{DD} = 5.5V	2.1		V
			V _{DD} = 4.5V	2.0		
			V _{DD} = 3.6V	1.9		
			V _{DD} = 3.0V	1.7		

Electrical Characteristics (continued)(V_{DD} = 3.0V to 5.5V, T_A = -40°C to +125°C, unless otherwise noted. Typical values are at V_{DD} = 5V, T_A = +25°C.) (Note 1)

PARAMETER	SYMBOL	CONDITIONS	MIN	TYP	MAX	UNITS
AC CHARACTERISTICS						
Power-Up Time	t _{POR}			404		ms
Enable Turn-On Time	t _{ON}	Figure 3, V _{IN} = $\pm 10V$, R _L = 10k Ω , C _L = 15pF			2	ms
Enable Turn-Off Time	t _{OFF}	Figure 3, V _{IN} = $\pm 10V$, R _L = 10k Ω , C _L = 15pF			1.5	ms
Break-Before-Make Interval	t _{BBM}	Figure 4, V _{IN} = $\pm 10V$, R _L = 10k Ω , C _L = 15pF		840		μs
Charge Injection	Q	Figure 5, V _{A_} = 0V, C _L = 1nF		1720		pC
Off-Isolation	V _{ISO}	Figure 6, V _{A_} = 1V _{RMS} , f = 100kHz, R _L = 50 Ω , C _L = 15pF		-80		dB
Crosstalk	V _{CT}	Figure 6, f = 100kHz, R _S = R _L = 50 Ω		-103		dB
-3dB Bandwidth	BW	Figure 6, R _S = 50 Ω , R _L = 50 Ω		75		MHz
Total Harmonic Distortion Plus Noise	THD+N	R _S = R _L = 1k Ω , f = 20Hz to 20kHz		0.003		%
Input Capacitance	C _{IN}	A_, B_ pins		78		pF
THERMAL PROTECTION						
Thermal-Shutdown Threshold	T _{SHUT}			145		°C
Thermal-Shutdown Hysteresis	T _{HYST}			25		°C
ESD PROTECTION						
A_, B_ Pins (Note 3)		Human Body Model		Q6		kV
All Other Pins		Human Body Model		Q2		kV

Note 1: All units are production tested at T_A = +25°C. Specifications over temperature are guaranteed by design.**Note 2:** When V_{DD} is higher than the charge-pump threshold, the internal 5V regulated charge pump is turned off and the input to the high-voltage charge pumps is provided by V_{DD}.**Note 3:** The MAX14778 requires a 100nF capacitor on both V_P and V_N to GND to guarantee full ESD protection. See the *Applications Information* section for details on ESD test conditions.

Test Circuits/Timing Diagrams

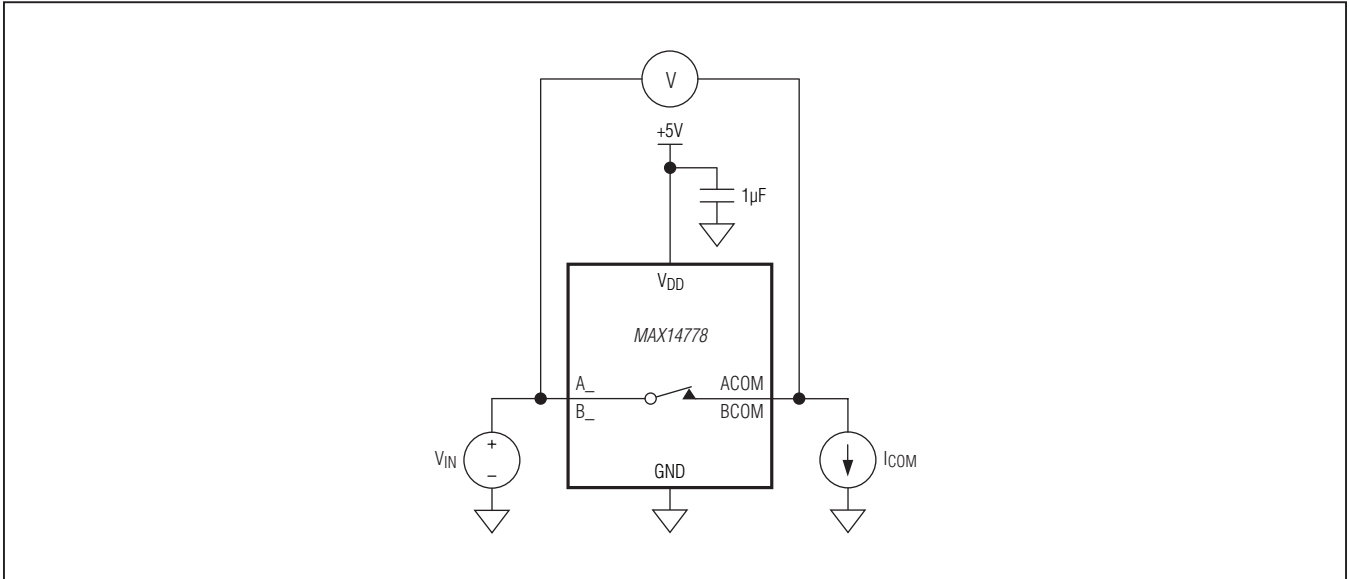

Figure 1. On-Resistance Measurement

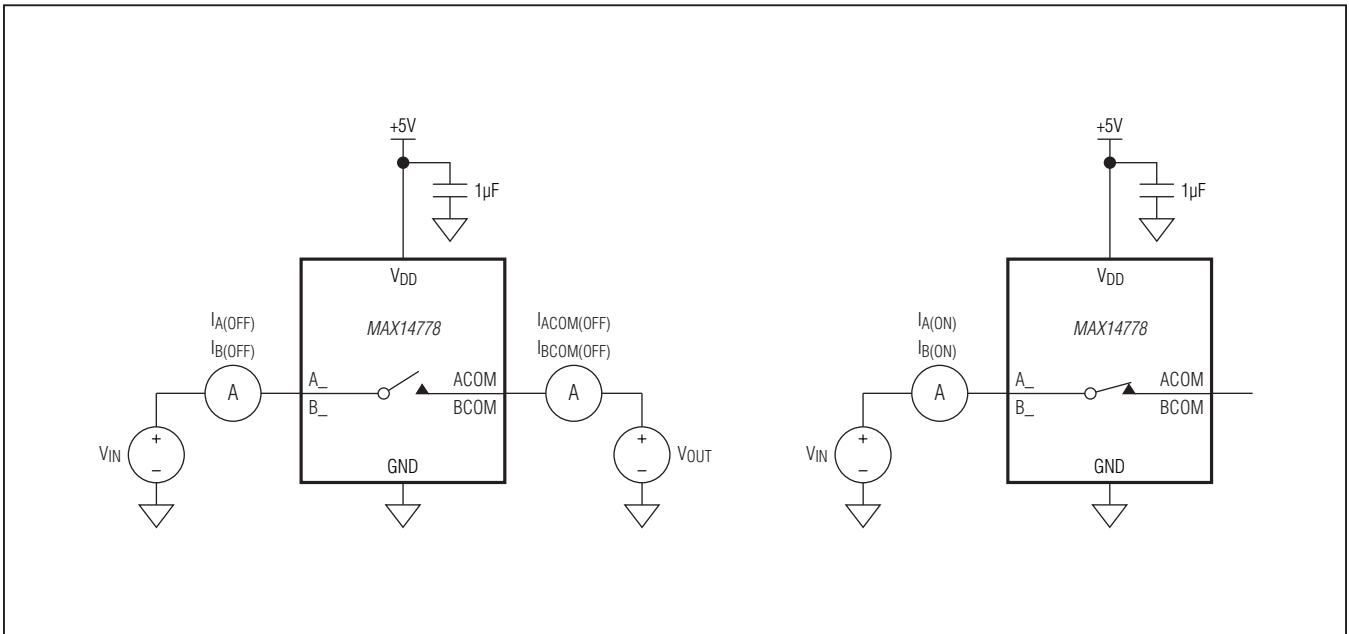

Figure 2. Leakage Current Measurement

Test Circuits/Timing Diagrams (continued)

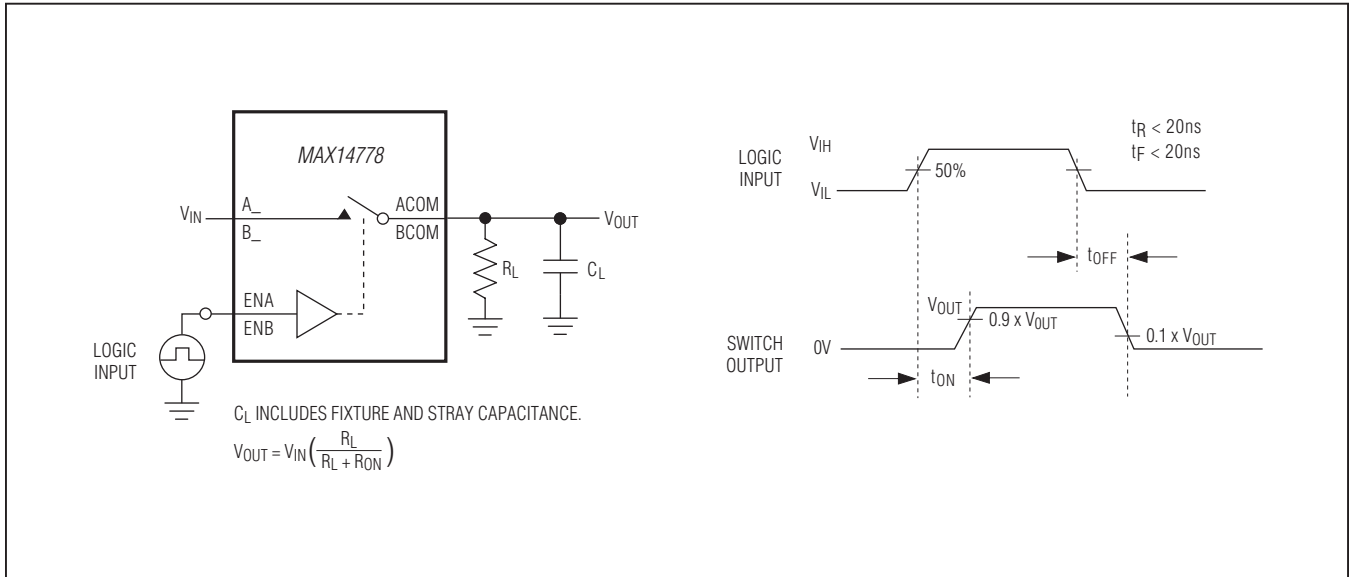

Figure 3. Turn-On/Turn-Off Timing

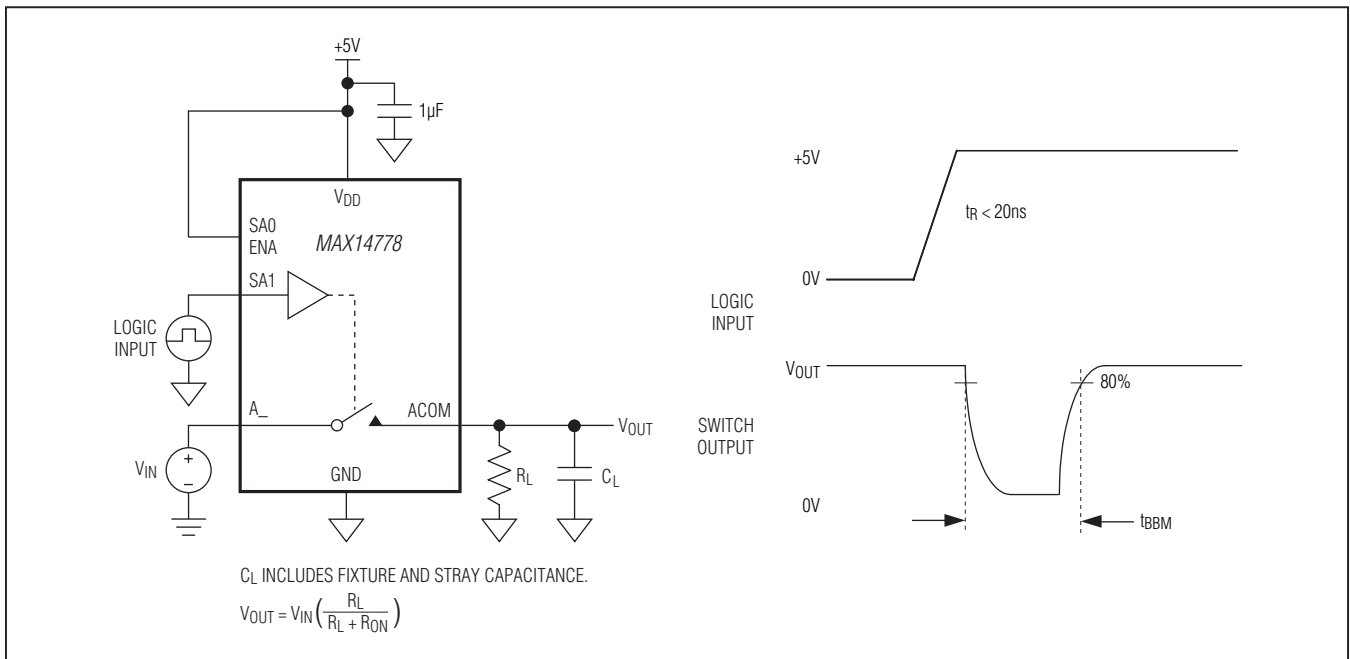

Figure 4. Break-Before-Make Timing

Test Circuits/Timing Diagrams (continued)

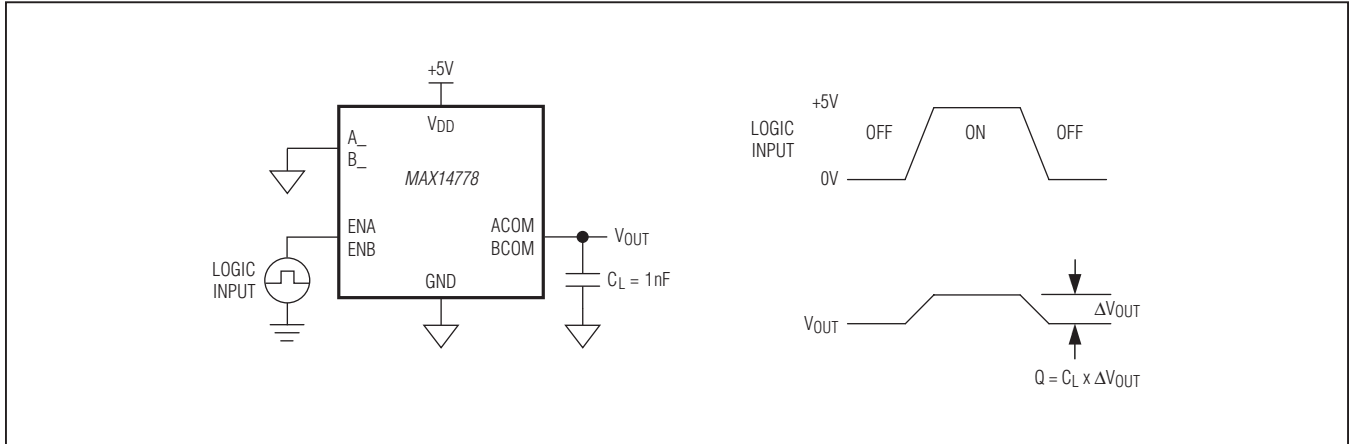

Figure 5. Charge Injection

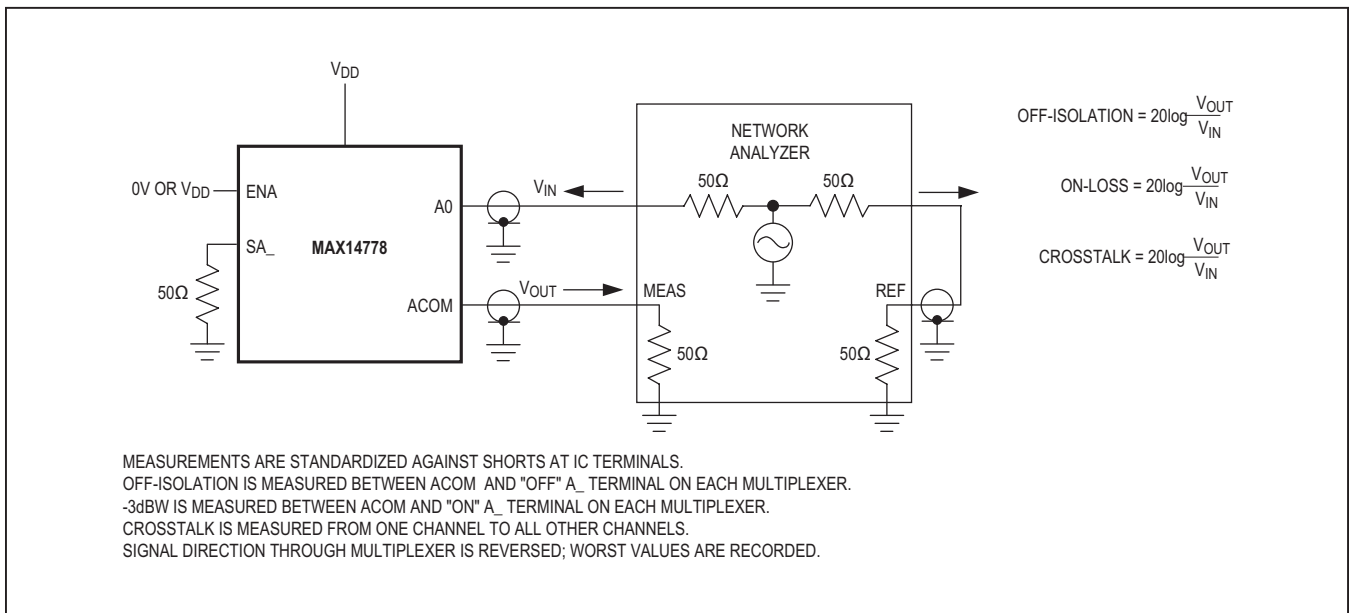
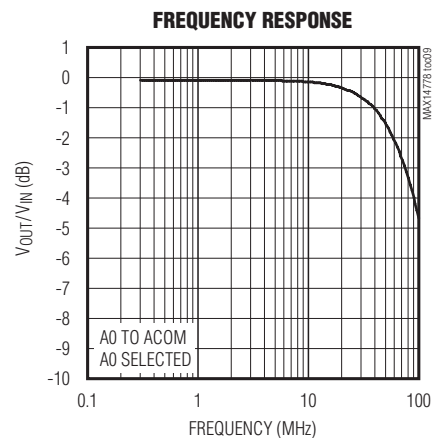
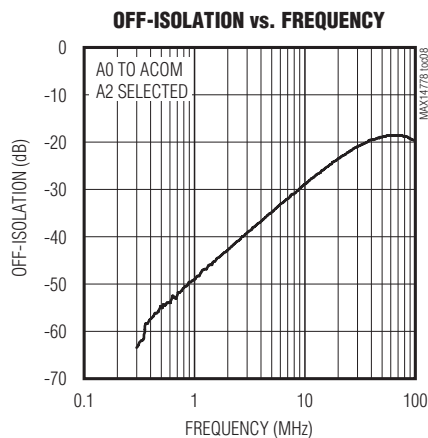
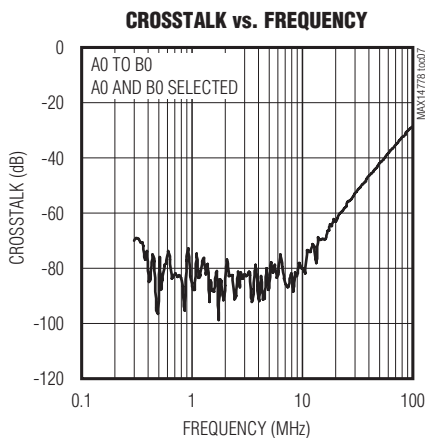
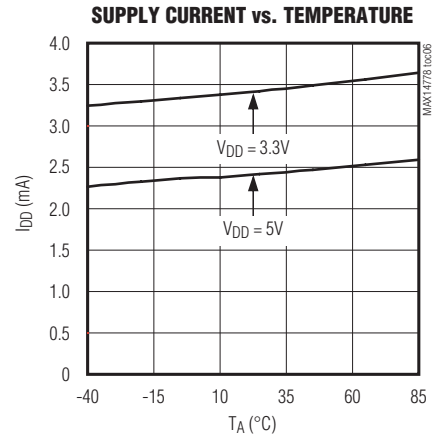
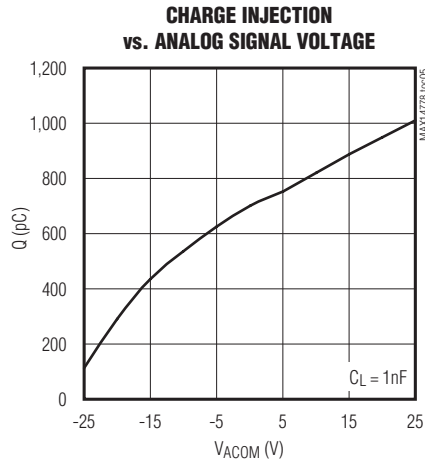
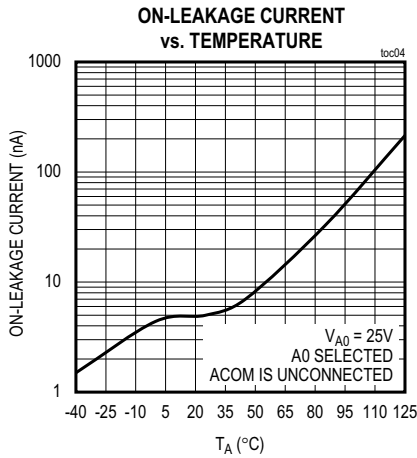
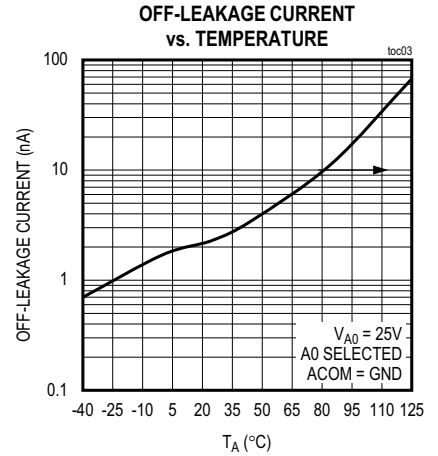
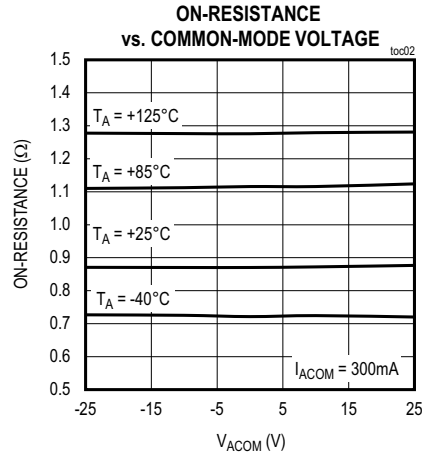
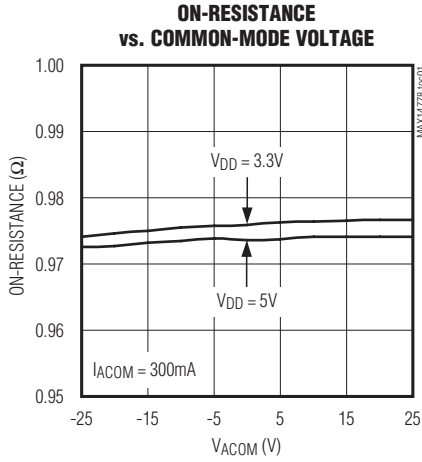

Figure 6. Off-Isolation, -3dB Bandwidth, and Crosstalk

Typical Operating Characteristics

($V_{DD} = 5.0V$, $T_A = +25^\circ C$, unless otherwise noted.)



Typical Operating Characteristics (continued)

($V_{DD} = 5.0V$, $T_A = +25^\circ C$, unless otherwise noted.)

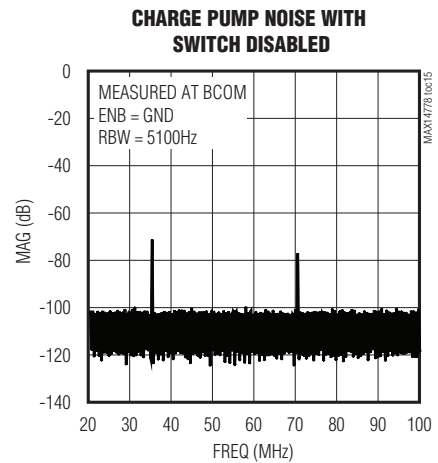
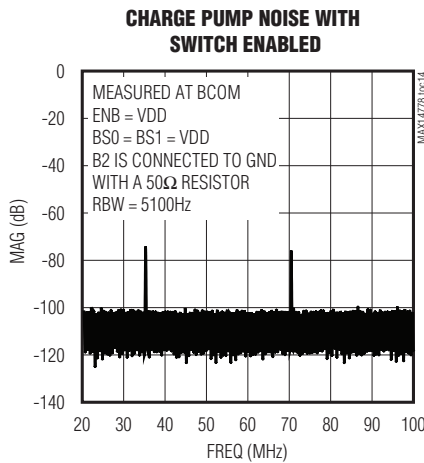
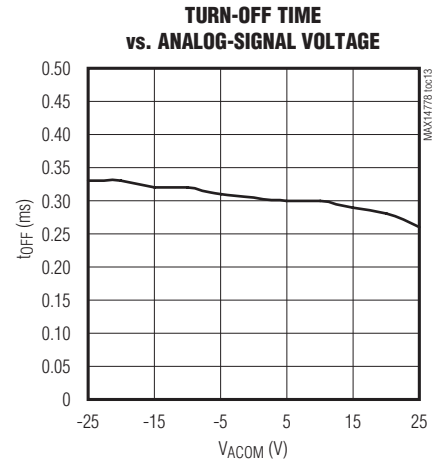
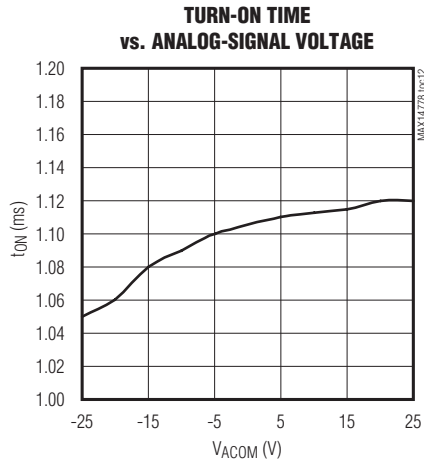
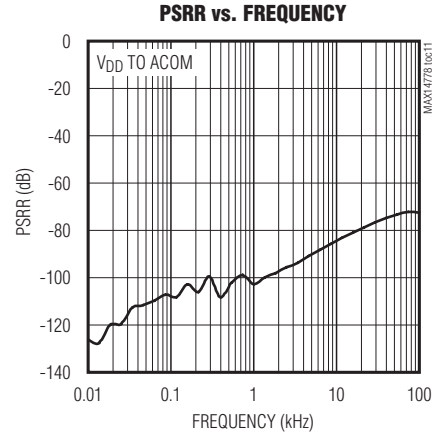
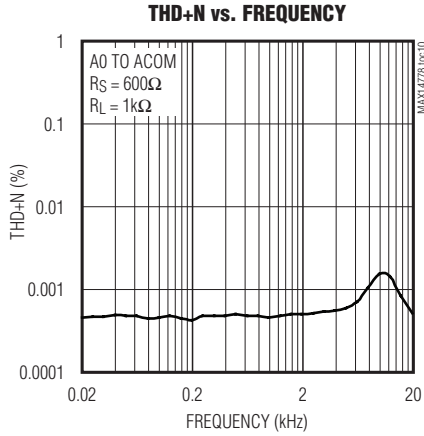

Pin Configuration

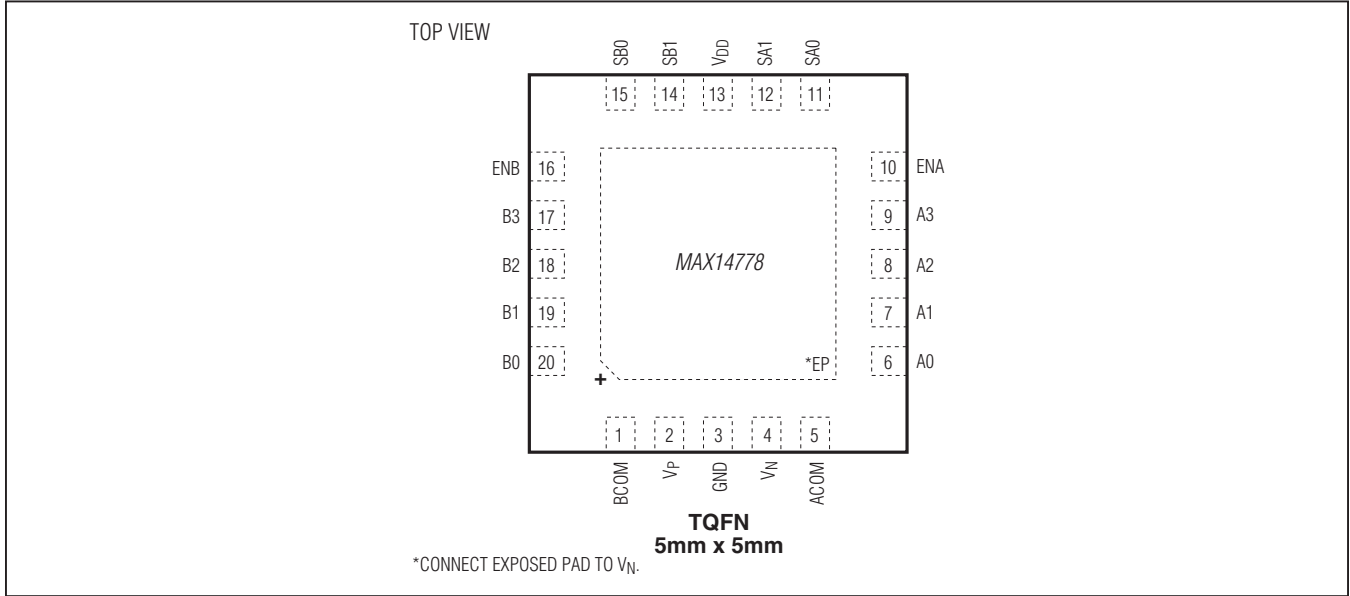

Pin Description

PIN	NAME	FUNCTION
1	BCOM	MUX B Common Terminal
2	V_P	Positive Charge-Pump Output. Bypass V_P to GND with a 100nF 50V ceramic capacitor.
3	GND	Ground
4	V_N	Negative Charge-Pump Output. Bypass V_N to GND with a 100nF 50V ceramic capacitor.
5	ACOM	MUX A Common Terminal
6	A0	MUX A Bidirectional Analog Input/Output 0
7	A1	MUX A Bidirectional Analog Input/Output 1
8	A2	MUX A Bidirectional Analog Input/Output 2
9	A3	MUX A Bidirectional Analog Input/Output 3
10	ENA	MUX A Enable Input
11	SA0	MUX A Channel Select Input 0
12	SA1	MUX A Channel Select Input 1
13	V_{DD}	Power-Supply Input. Bypass V_{DD} to GND with a 1 μ F ceramic capacitor.
14	SB1	MUX B Channel Select Input 1
15	SB0	MUX B Channel Select Input 0
16	ENB	MUX B Enable Input
17	B3	MUX B Bidirectional Analog Input/Output 3
18	B2	MUX B Bidirectional Analog Input/Output 2
19	B1	MUX B Bidirectional Analog Input/Output 1
20	B0	MUX B Bidirectional Analog Input/Output 0
—	EP	Exposed Pad. Connect EP to V_N . EP is not intended as an electrical connection point.

Truth Tables

Table 1. MUX A Channel Selection

ENA	SA1	SA0	ACOM CONNECTED TO
0	X	X	Open
1	0	0	A0
1	0	1	A1
1	1	0	A2
1	1	1	A3

X = Don't care

Table 2. MUX B Channel Selection

ENB	SB1	SB0	BCOM CONNECTED TO
0	X	X	Open
1	0	0	B0
1	0	1	B1
1	1	0	B2
1	1	1	B3

X = Don't care

Detailed Description

The MAX14778 dual 4:1 analog multiplexer integrates bias circuitry to provide a $\pm 25V$ analog voltage range with a single 3.0 to 5.5V supply. This extended input range allows multiplexing different communications signals such as RS-232, RS-485, audio and USB 1.1 onto the same connector.

Integrated Bias Generation

The MAX14778 contains a total of three charge pumps to generate bias voltages for the internal switches: a 5V regulated charge pump, a positive high-voltage (+35V) charge pump, and a negative high-voltage (-27V) charge pump. When V_{DD} is above 4.7V (typ), the 5V regulated charge pump is bypassed and V_{DD} provides the input for the high-voltage charge pumps, reducing overall supply current.

An external 100nF capacitor is required for each high-voltage charge pump between V_P/V_N and GND.

Analog Signal Levels

The MAX14778 transmits signals of up to $\pm 25V$ with a single 3.0 to 5.5V supply due to integrated bias circuitry. The device features 1.5 Ω (max) on-resistance and 3m Ω (typ) flatness for analog signals between -25V and +25V (see the [Typical Operating Characteristics](#)). The current flow through the multiplexers can be bidirectional, allowing operation either as a multiplexer or demultiplexer.

Digital Interface

The MAX14778 has two digital select inputs for each MUX: SA1 and SA0 control MUX A; SB1 and SB0 control MUX B. Drive the digital select inputs high or low to select which input (A_, B_) is connected to the common terminal (ACOM, BCOM) for each MUX. See the [Truth Tables](#) for more information.

Each MUX features an independent enable input (ENA and ENB). Drive ENA or ENB low to disconnect all inputs from the common terminal for that MUX, regardless of the status of the select inputs or the other enable input.

Applications Information

Connector Sharing

The MAX14778 supports a $\pm 25V$ analog signal range independently for each input/output, allowing physical connector sharing between interface types that have differing signal ranges.

The multiprotocol connector-sharing application in the [Typical Operating Circuits](#) shows an application with RS-232, half-duplex RS-485, full-speed USB 1.1, and audio signals sharing the same connector. The device allows signals to pass over the entire signal range specified by each standard while safely isolating the unused transceivers.

Non-Powered Condition

The MAX14778 can tolerate input voltages on the A₋, B₋, ACOM, and BCOM pins in the $\pm 25V$ range when it is not powered.

When VDD = 0V, the DC input leakage current into the A₋, B₋, ACOM or BCOM pins will typically be below 1 μA . Some devices can have a larger leakage current up to mA range due to technology spread.

With VDD not powered, internal diodes between the analog pins and the VP and VN will charge up the external capacitors on VP and VN when positive and/or negative voltages are applied to these pins. This causes transient input current flow.

Large dv/dt on the inputs causes large capacitive charging currents, which have to be limited to the 300mA Absolute Maximum Ratings in order to not destroy the internal diodes. With 100nF capacitors on VP and VN, the dv/dt must be limited to 3V/ μs once the capacitors reach their final voltage; the input current decays to the leakage current levels mentioned above.

High-ESD Protection

Electrostatic discharge (ESD)-protection structures are incorporated on all pins to protect against electrostatic discharges up to $\pm 2kV$ Human Body Model (HBM) encountered during handling and assembly. A₋ and B₋ are further protected against ESD up to $\pm 6kV$ (HBM) without damage. The ESD structures withstand high ESD both in normal operation and when the device is powered down. After an ESD event, the MAX14778 continues to function without latchup.

ESD Test Conditions

ESD performance depends on a variety of conditions. Contact Maxim for a reliability report that documents test setup, test methodology, and test results.

The MAX14778 requires a 100nF capacitor on both V_p and V_N to GND to guarantee full ESD protection.

Human Body Model

Figure 7 shows the Human Body Model. Figure 8 shows the current waveform it generates when discharged into a low impedance. This model consists of a 100pF capacitor charged to the ESD voltage of interest that is then discharged into the device through a 1.5k Ω resistor.

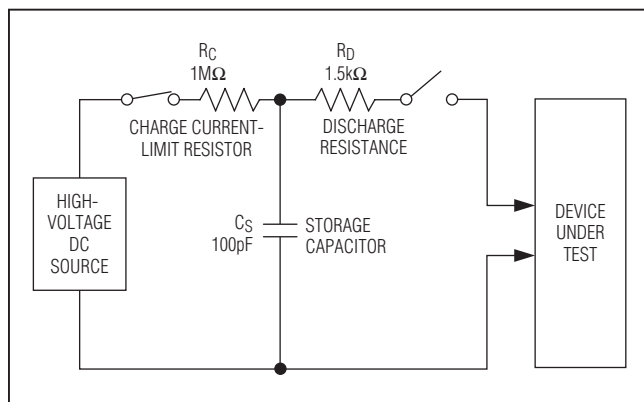

Figure 7. Human Body ESD Test Model

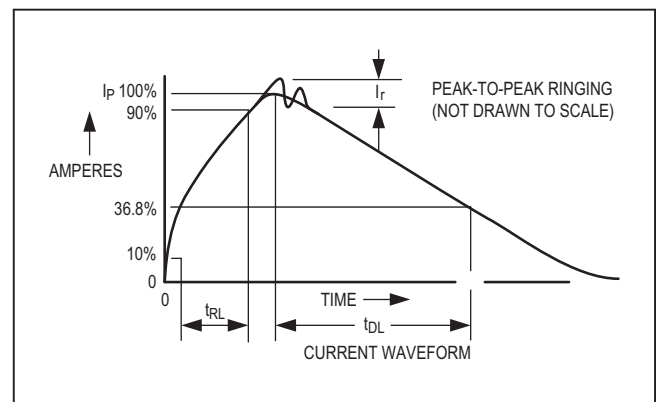
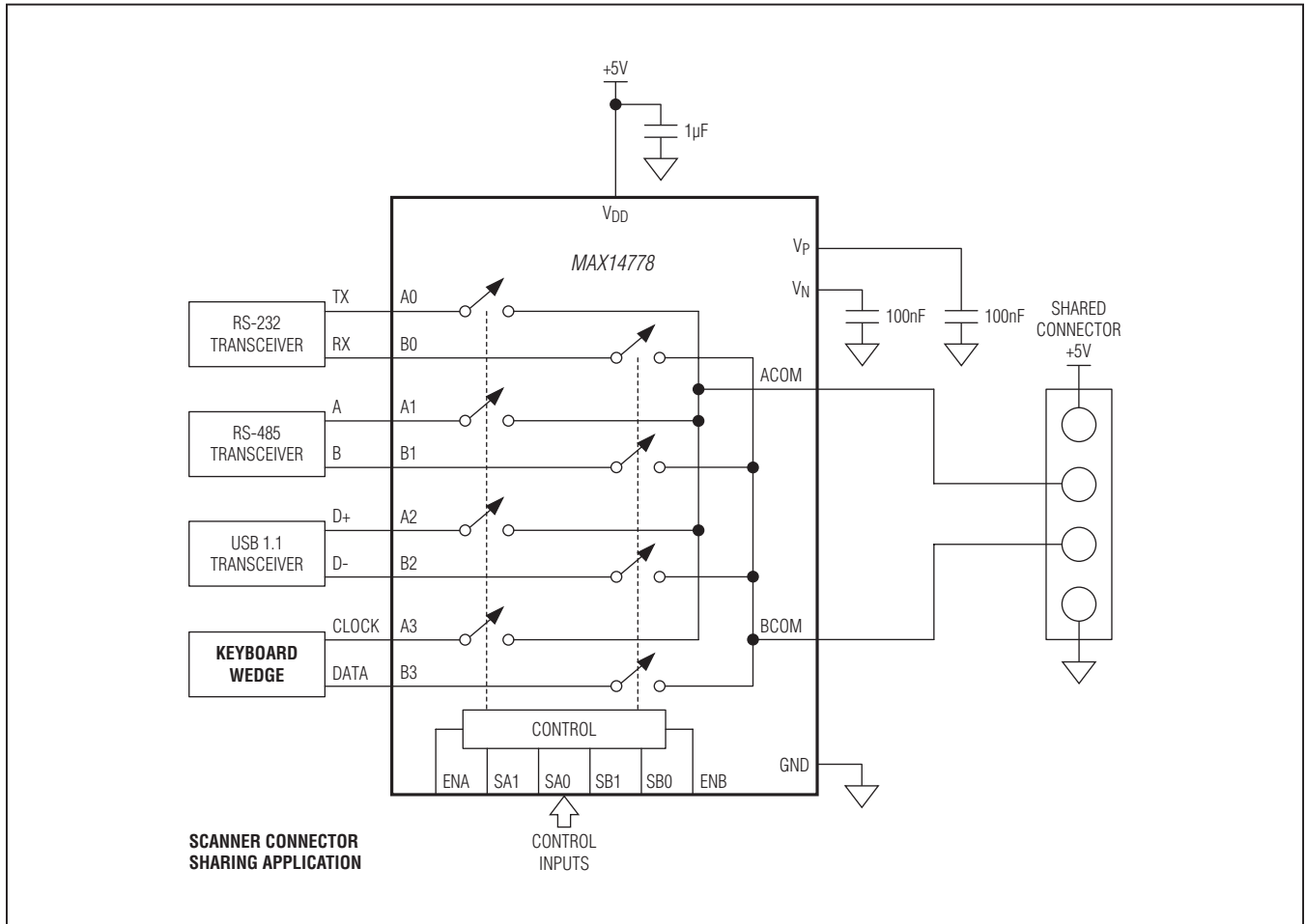

Figure 8. Human Body Current Waveform

Typical Operating Circuits



Typical Operating Circuits (continued)



MAX14778

Dual $\pm 25V$ Above- and Below-the-Rails
4:1 Analog Multiplexer

Ordering Information

PART	TEMP RANGE	PIN-PACKAGE
MAX14778ATP+	-40°C to +125°C	20 TQFN-EP*
MAX14778ETP+	-40°C to +85°C	20 TQFN-EP*

+Denotes a lead(Pb)-free/RoHS-compliant package.

*EP = Exposed pad.

Chip Information

PROCESS: BiCMOS

Revision History

REVISION NUMBER	REVISION DATE	DESCRIPTION	PAGES CHANGED
0	6/11	Initial release	—
1	6/12	Added new TOCs 14 and 15, updated <i>Non-Powered Condition</i> section, updated Note 4, <i>Pin Description</i> , <i>ESD Test Conditions</i> , <i>Typical Operating Circuits</i> , updated capacitor values	3, 8, 9, 10, 11, 12, 13
2	5/15	Revised <i>Benefits and Features</i> section	1
3	7/20	Updated the <i>General Description</i> , <i>Benefits and Features</i> , <i>Absolute Maximum Ratings</i> , <i>Electrical Characteristics</i> , and <i>Ordering Information</i> sections, and TOC02–TOC04	1–4, 8, 15

For pricing, delivery, and ordering information, please visit Maxim Integrated's online storefront at <https://www.maximintegrated.com/en/storefront/storefront.html>.

Maxim Integrated cannot assume responsibility for use of any circuitry other than circuitry entirely embodied in a Maxim Integrated product. No circuit patent licenses are implied. Maxim Integrated reserves the right to change the circuitry and specifications without notice at any time. The parametric values (min and max limits) shown in the Electrical Characteristics table are guaranteed. Other parametric values quoted in this data sheet are provided for guidance.

Looking for pricing, stock, or lifecycle information?

Click below to explore more details on WIN SOURCE:

 [View MAX14778ETP+ on WIN SOURCE](#)

 [Maxim Integrated](#) Information

Optimize Your Supply Chain with WIN SOURCE Solutions

-  Global Sourcing Solution
-  Obsolete Management
-  Cost Control Management
-  Shortage Management
-  Alternative Solution
-  Excess Inventory Management