



**THE DATASHEET OF
LT6109AHMS-1#PBF**



High Side Current Sense Amplifier with Reference and Comparators

FEATURES

- Current Sense Amplifier
 - Fast Step Response: 500ns
 - Low Offset Voltage: 125 μ V Maximum
 - Low Gain Error: 0.2% Maximum
- Internal 400mV Precision Reference
- Internal Latching Comparators with Reset
 - Fast Response Time: 500ns
 - Total Threshold Error: \pm 1.25% Maximum
 - Two Comparator Polarity Options
- Wide Supply Range: 2.7V to 60V
- Supply Current: 550 μ A
- Low Shutdown Current: 5 μ A Maximum
- Specified for -40° C to 125° C Temperature Range
- Available in 10-Lead MSOP Package

APPLICATIONS

- Overcurrent, Undercurrent and Fault Detection
- Current Shunt Measurement
- Battery Monitoring
- Motor Control
- Automotive Monitoring and Control
- Remote Sensing
- Industrial Control

DESCRIPTION

The LT[®]6109 is a complete high side current sense device that incorporates a precision current sense amplifier, an integrated voltage reference and two comparators. Two versions of the LT6109 are available. The LT6109-1 has the comparators connected in opposing polarity and the LT6109-2 has the comparators connected in the same polarity. In addition, the current sense amplifier and comparator inputs and outputs are directly accessible. The amplifier gain and comparator trip points are configured by external resistors. The open-drain comparator outputs allows for easy interface to other system components.

The overall propagation delay of the LT6109 is typically only 1.4 μ s, allowing for quick reaction to overcurrent and undercurrent conditions. The 1MHz bandwidth allows the LT6109 to be used for error detection in critical applications such as motor control. The high threshold accuracy of the comparators, combined with the ability to latch both comparators, ensures the LT6109 can capture high speed events.

The LT6109 is fully specified for operation from -40° C to 125° C, making it suitable for industrial and automotive applications. The LT6109 is available in a small 10-lead MSOP.

LT, LT, LTC, LTM, TimerBlox, Linear Technology and the Linear logo are registered trademarks of Linear Technology Corporation. All other trademarks are the property of their respective owners.

TYPICAL APPLICATION

Circuit Fault Protection with Latching Load Disconnect and Early Warning Indication

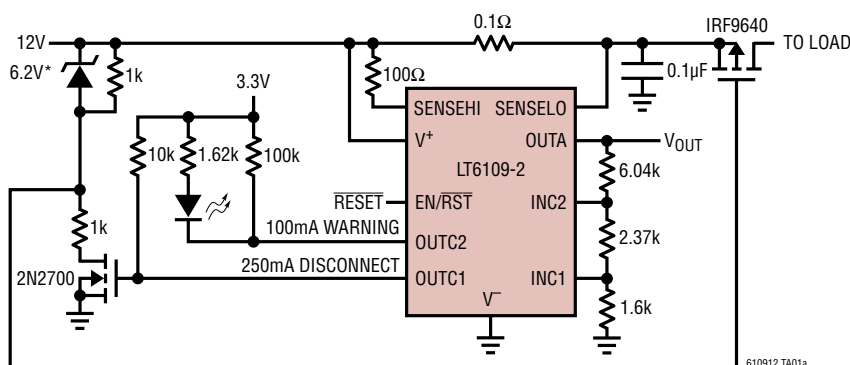

*CMH25234B

610912 TA01a

Response to Overcurrent Event

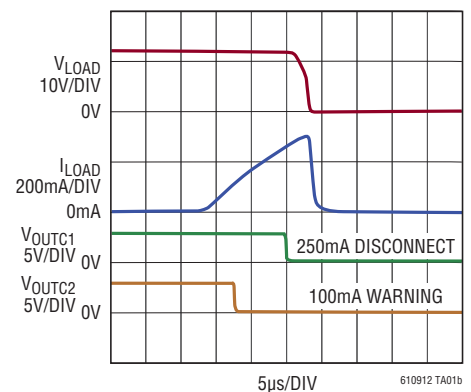

610912 TA01b

610912fa

LT6109-1/LT6109-2

ABSOLUTE MAXIMUM RATINGS

(Note 1)

Total Supply Voltage (V^+ to V^-)	60V
Maximum Voltage (SENSELO, SENSEHI, OUTA)	$V^+ + 1V$
Maximum $V^+ -$ (SENSELO or SENSEHI)	33V
Maximum EN/\overline{RST} Voltage	60V
Maximum Comparator Input Voltage	60V
Maximum Comparator Output Voltage	60V
Input Current (Note 2)	-10mA
SENSEHI, SENSELO Input Current	$\pm 10mA$
Differential SENSEHI or SENSELO Input Current	$\pm 2.5mA$
Amplifier Output Short-Circuit Duration (to V^-)	Indefinite
Operating Temperature Range (Note 3)	
LT6109I	-40°C to 85°C
LT6109H	-40°C to 125°C
Specified Temperature Range (Note 3)	
LT6109I	-40°C to 85°C
LT6109H	-40°C to 125°C
Maximum Junction Temperature	150°C
Storage Temperature Range	-65°C to 150°C
Lead Temperature (Soldering, 10 sec)	300°C

PIN CONFIGURATION

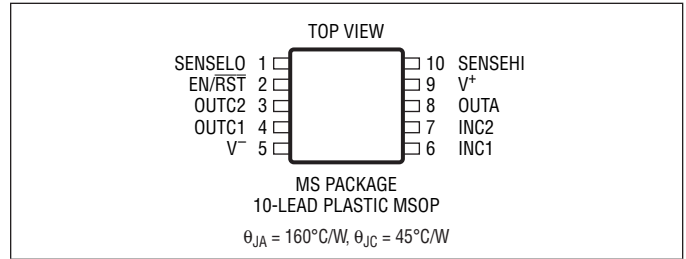

ORDER INFORMATION

LEAD FREE FINISH	TAPE AND REEL	PART MARKING*	PACKAGE DESCRIPTION	SPECIFIED TEMPERATURE RANGE
LT6109AIMS-1#PBF	LT6109AIMS-1#TRPBF	LTFNJ	10-Lead Plastic MSOP	-40°C to 85°C
LT6109IMS-1#PBF	LT6109IMS-1#TRPBF	LTFNJ	10-Lead Plastic MSOP	-40°C to 85°C
LT6109AHMS-1#PBF	LT6109AHMS-1#TRPBF	LTFNJ	10-Lead Plastic MSOP	-40°C to 125°C
LT6109HMS-1#PBF	LT6109HMS-1#TRPBF	LTFNJ	10-Lead Plastic MSOP	-40°C to 125°C
LT6109AIMS-2#PBF	LT6109AIMS-2#TRPBF	LTFWY	10-Lead Plastic MSOP	-40°C to 85°C
LT6109IMS-2#PBF	LT6109IMS-2#TRPBF	LTFWY	10-Lead Plastic MSOP	-40°C to 85°C
LT6109AHMS-2#PBF	LT6109AHMS-2#TRPBF	LTFWY	10-Lead Plastic MSOP	-40°C to 125°C
LT6109HMS-2#PBF	LT6109HMS-2#TRPBF	LTFWY	10-Lead Plastic MSOP	-40°C to 125°C

Consult LTC Marketing for parts specified with wider operating temperature ranges. *The temperature grade is identified by a label on the shipping container. Consult LTC Marketing for information on non-standard lead based finish parts.

For more information on lead free part marking, go to: <http://www.linear.com/leadfree/>

For more information on tape and reel specifications, go to: <http://www.linear.com/tapeandreeel/>

ELECTRICAL CHARACTERISTICS The ● denotes the specifications which apply over the full operating temperature range, otherwise specifications are at T_A = 25°C. V⁺ = 12V, V_{PULLUP} = V⁺, V_{EN/RST} = 2.7V, R_{IN} = 100Ω, R_{OUT} = R₁ + R₂ + R₃ = 10k, gain = 100, R_C = 25.5k, C_L = C_{LC} = 2pF, unless otherwise noted. (See Figure 3)

SYMBOL	PARAMETER	CONDITIONS	MIN	TYP	MAX	UNITS
V ⁺	Supply Voltage Range		● 2.7		60	V
I _S	Supply Current (Note 4)	V ⁺ = 2.7V, R _{IN} = 1k, V _{SENSE} = 5mV		475		μA
		V ⁺ = 60V, R _{IN} = 1k, V _{SENSE} = 5mV	●	600	700 1000	μA μA
	Supply Current in Shutdown	V ⁺ = 2.7V, V _{EN/RST} = 0V, R _{IN} = 1k, V _{SENSE} = 0.5V	●	3	5 7	μA μA
		V ⁺ = 60V, V _{EN/RST} = 0V, R _{IN} = 1k, V _{SENSE} = 0.5V	●	7	11 13	μA μA
	EN/RST Pin Current	V _{EN/RST} = 0V, V ⁺ = 60V		-200		nA
V _{IH}	EN/RST Pin Input High	V ⁺ = 2.7V to 60V	●	1.9		V
V _{IL}	EN/RST Pin Input Low	V ⁺ = 2.7V to 60V	●		0.8	V

Current Sense Amplifier

V _{OS}	Input Offset Voltage	V _{SENSE} = 5mV, LT6109A		-125	125	μV
		V _{SENSE} = 5mV, LT6109		-350	350	μV
		V _{SENSE} = 5mV, LT6109A	●	-250	250	μV
		V _{SENSE} = 5mV, LT6109	●	-450	450	μV
ΔV _{OS} /ΔT	Input Offset Voltage Drift	V _{SENSE} = 5mV	●	±0.8		μV/°C
I _B	Input Bias Current (SENSELO, SENSEHI)	V ⁺ = 2.7V to 60V	●	60	300 350	nA nA
I _{OS}	Input Offset Current	V ⁺ = 2.7V to 60V		±5		nA
I _{OUTA}	Output Current (Note 5)		●	1		mA
PSRR	Power Supply Rejection Ratio (Note 6)	V ⁺ = 2.7V to 60V	●	120 114	127	dB dB
CMRR	Common Mode Rejection Ratio	V ⁺ = 36V, V _{SENSE} = 5mV, V _{ICM} = 2.7V to 36V			125	dB
		V ⁺ = 60V, V _{SENSE} = 5mV, V _{ICM} = 27V to 60V	●	110 103	125	dB dB
V _{SENSE(MAX)}	Full-Scale Input Sense Voltage (Note 5)	R _{IN} = 500Ω	●	500		mV
	Gain Error (Note 7)	V ⁺ = 2.7V to 12V			-0.08	%
		V ⁺ = 12V to 60V, V _{SENSE} = 5mV to 100mV	●	-0.2	0	%
	SENSELO Voltage (Note 8)	V ⁺ = 2.7V, V _{SENSE} = 100mV, R _{OUT} = 2k	●	2.5		V
		V ⁺ = 60V, V _{SENSE} = 100mV	●	27		V
	Output Swing High (V ⁺ to V _{OUTA})	V ⁺ = 2.7V, V _{SENSE} = 27mV	●		0.2	V
		V ⁺ = 12V, V _{SENSE} = 120mV	●		0.5	V
BW	Signal Bandwidth	I _{OUT} = 1mA		1		MHz
		I _{OUT} = 100μA		140		kHz
t _r	Input Step Response (to 50% of Final Output Voltage)	V ⁺ = 2.7V, V _{SENSE} = 24mV Step, Output Rising Edge		500		ns
		V ⁺ = 12V to 60V, V _{SENSE} = 100mV Step, Output Rising Edge		500		ns
t _{SETTLE}	Settling Time to 1%	V _{SENSE} = 10mV to 100mV, R _{OUT} = 2k		2		μs

LT6109-1/LT6109-2

ELECTRICAL CHARACTERISTICS The ● denotes the specifications which apply over the full operating temperature range, otherwise specifications are at $T_A = 25^\circ\text{C}$. $V^+ = 12\text{V}$, $V_{\text{PULLUP}} = V^+$, $V_{\text{EN/RST}} = 2.7\text{V}$, $R_{\text{IN}} = 100\Omega$, $R_{\text{OUT}} = R_1 + R_2 + R_3 = 10\text{k}$, gain = 100, $R_C = 25.5\text{k}$, $C_L = C_{LC} = 2\text{pF}$, unless otherwise noted. (See Figure 3)

SYMBOL	PARAMETER	CONDITIONS	MIN	TYP	MAX	UNITS	
Reference and Comparator							
$V_{\text{TH(R)}}$ (Note 9)	Rising Input Threshold Voltage (LT6109-1 Comparator 1 LT6109-2 Both Comparators)	$V^+ = 2.7\text{V to } 60\text{V}$, LT6109A $V^+ = 2.7\text{V to } 60\text{V}$, LT6109	●	395	400	405	mV
			●	392	400	408	mV
$V_{\text{TH(F)}}$ (Note 9)	Falling Input Threshold Voltage (LT6109-1 Comparator 2)	$V^+ = 2.7\text{V to } 60\text{V}$, LT6109A $V^+ = 2.7\text{V to } 60\text{V}$, LT6109	●	395	400	405	mV
			●	392	400	408	mV
V_{HYS}	$V_{\text{HYS}} = V_{\text{TH(R)}} - V_{\text{TH(F)}}$	$V^+ = 2.7\text{V to } 60\text{V}$		3	10	15	mV
	Comparator Input Bias Current	$V_{\text{INC1,2}} = 0\text{V}$, $V^+ = 60\text{V}$	●	-50			nA
V_{OL}	Output Low Voltage	$I_{\text{OUTC1,C2}} = 500\mu\text{A}$, $V^+ = 2.7\text{V}$	●		60	150	mV
						220	mV
	High to Low Propagation Delay	5mV Overdrive 100mV Overdrive			3		μs
					0.5		μs
	Output Fall Time				0.08		μs
t_{RESET}	Reset Time				0.5		μs
t_{RPW}	Valid $\overline{\text{RST}}$ Pulse Width		●	2		15	μs

Note 1: Stresses beyond those listed under Absolute Maximum Ratings may cause permanent damage to the device. Exposure to any Absolute Maximum Rating condition for extended periods may affect device reliability and lifetime.

Note 2: Input and output pins have ESD diodes connected to ground. The SENSEHI and SENSELO pins have additional current handling capability specified as SENSEHI, SENSELO input current.

Note 3: The LT6109I is guaranteed to meet specified performance from -40°C to 85°C . LT6109H is guaranteed to meet specified performance from -40°C to 125°C .

Note 4: Supply current is specified with the comparator outputs high. When the comparator outputs go low the supply current will increase by $75\mu\text{A}$ typically per comparator.

Note 5: The full-scale input sense voltage and the maximum output current must be considered to achieve the specified performance.

Note 6: Supply voltage and input common mode voltage are varied while amplifier input offset voltage is monitored.

Note 7: Specified gain error does not include the effects of external resistors R_{IN} and R_{OUT} . Although gain error is only guaranteed between 12V and 60V, similar performance is expected for $V^+ < 12\text{V}$, as well.

Note 8: Refer to SENSELO, SENSEHI Range in the Applications Information section for more information.

Note 9: The input threshold voltage which causes the output voltage of the comparator to transition from high to low is specified. The input voltage which causes the comparator output to transition from low to high is the magnitude of the difference between the specified threshold and the hysteresis.

TYPICAL PERFORMANCE CHARACTERISTICS Performance characteristics taken at $T_A = 25^\circ\text{C}$, $V^+ = 12\text{V}$, $V_{\text{PULLUP}} = V^+$, $V_{\text{EN/RST}} = 2.7\text{V}$, $R_{\text{IN}} = 100\Omega$, $R_{\text{OUT}} = R_1 + R_2 + R_3 = 10\text{k}$, gain = 100, $R_C = 25.5\text{k}$, $C_L = C_{\text{LC}} = 2\text{pF}$, unless otherwise noted. (See Figure 3)

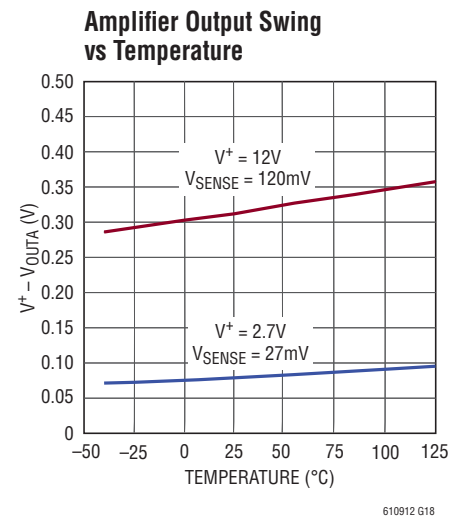
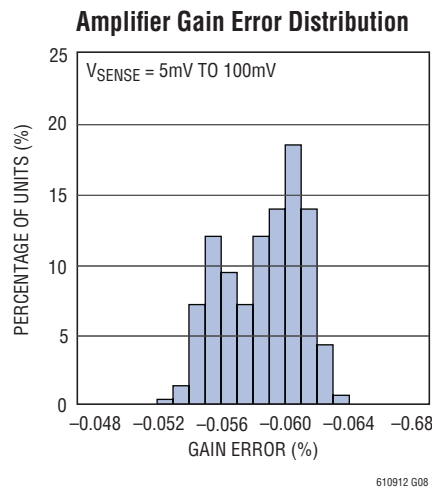
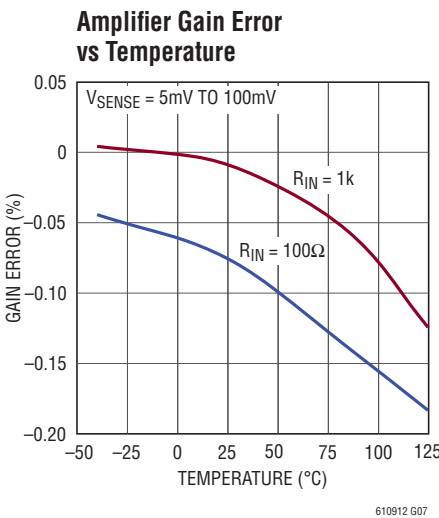
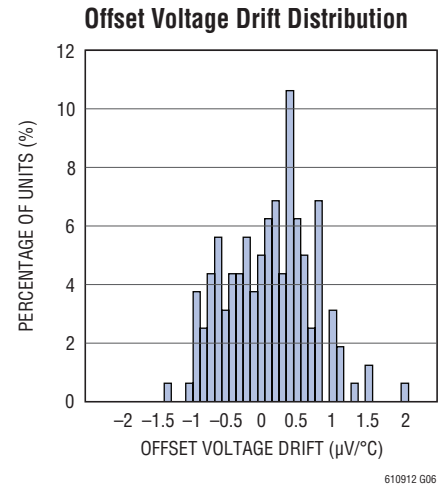
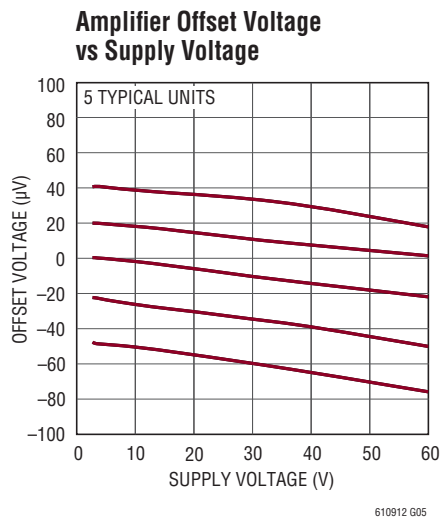
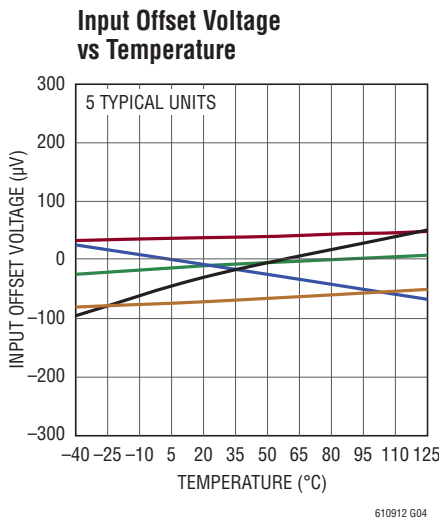
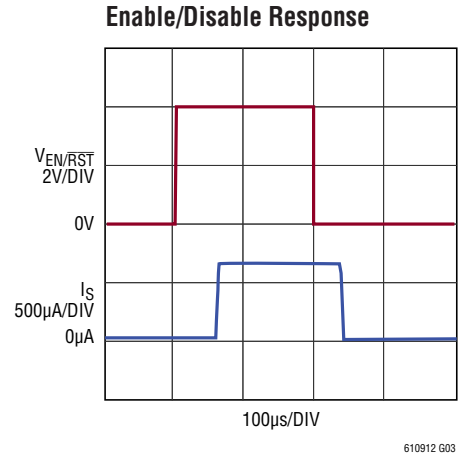
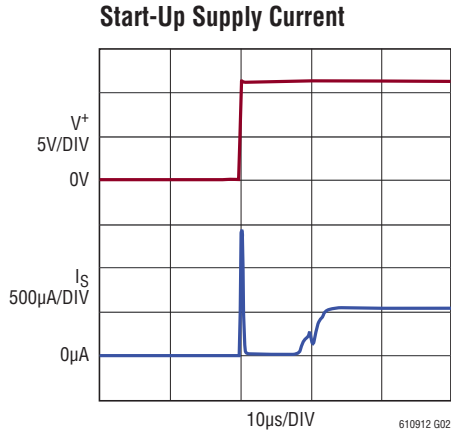
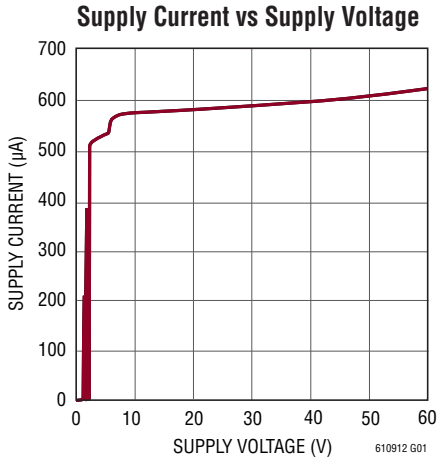

LT6109-1/LT6109-2

TYPICAL PERFORMANCE CHARACTERISTICS Performance characteristics taken at $T_A = 25^\circ\text{C}$, $V^+ = 12\text{V}$, $V_{\text{PULLUP}} = V^+$, $V_{\text{EN/RST}} = 2.7\text{V}$, $R_{\text{IN}} = 100\Omega$, $R_{\text{OUT}} = R1 + R2 + R3 = 10\text{k}$, gain = 100, $R_C = 25.5\text{k}$, $C_L = C_{\text{LC}} = 2\text{pF}$, unless otherwise noted. (See Figure 3)

Power Supply Rejection Ratio vs Frequency

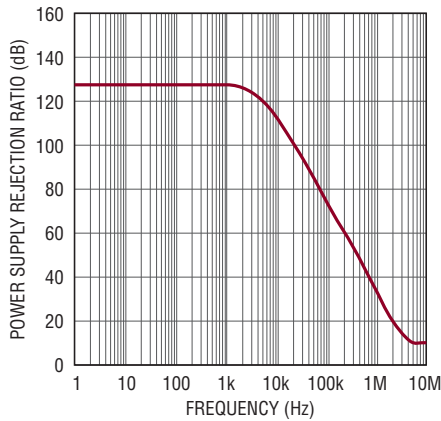

610912 G09

Common Mode Rejection Ratio vs Frequency

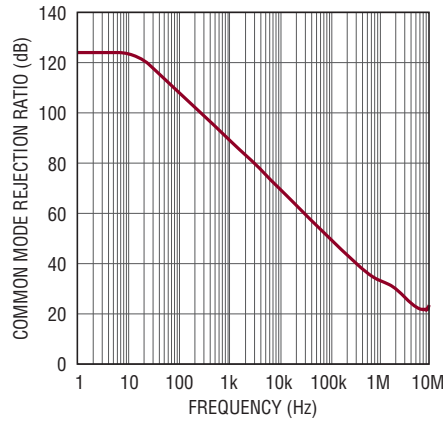

610912 G10

Amplifier Gain vs Frequency

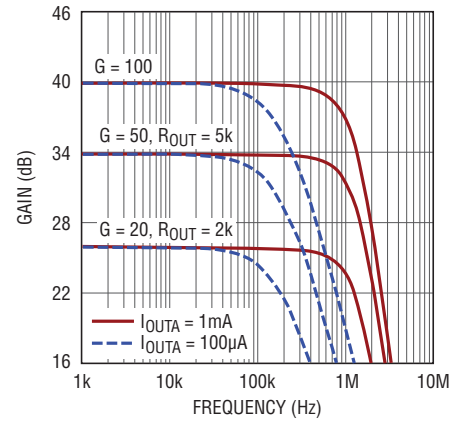

610912 G11

System Step Response

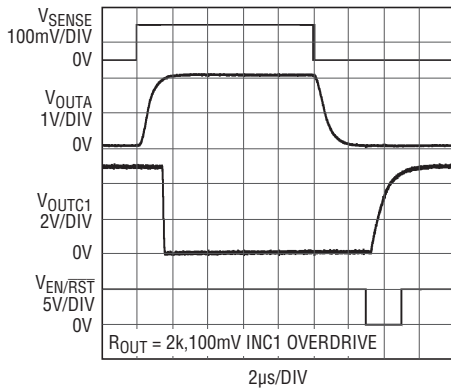

610912 G12

Amplifier Input Bias Current vs Temperature

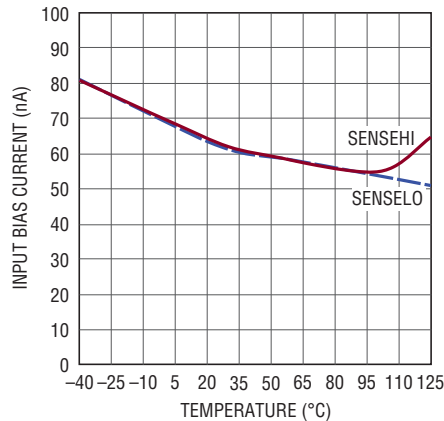

610912 G13

Amplifier Step Response ($V_{\text{SENSE}} = 0\text{mV}$ to 100mV)

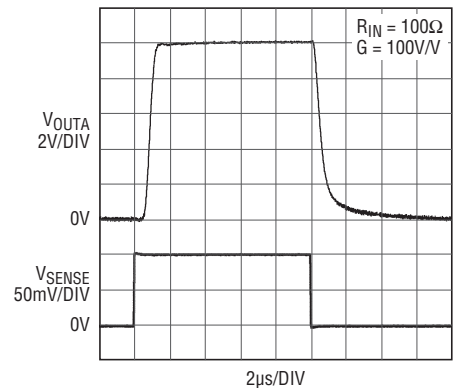

610912 G14

Amplifier Step Response ($V_{\text{SENSE}} = 10\text{mV}$ to 100mV)

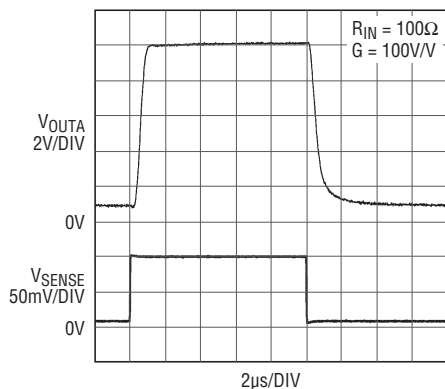

610912 G15

Amplifier Step Response ($V_{\text{SENSE}} = 0\text{mV}$ to 100mV)

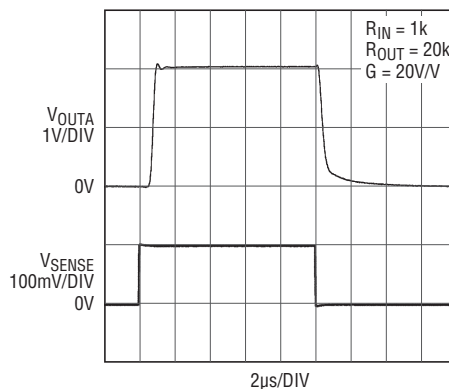

610912 G16

Amplifier Step Response ($V_{\text{SENSE}} = 10\text{mV}$ to 100mV)

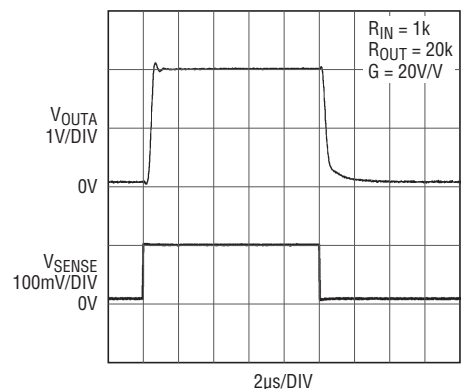

610912 G17

610912fa

TYPICAL PERFORMANCE CHARACTERISTICS Performance characteristics taken at $T_A = 25^\circ\text{C}$, $V^+ = 12\text{V}$, $V_{\text{PULLUP}} = V^+$, $V_{\text{EN/RST}} = 2.7\text{V}$, $R_{\text{IN}} = 100\Omega$, $R_{\text{OUT}} = R1 + R2 + R3 = 10\text{k}$, gain = 100, $R_C = 25.5\text{k}$, $C_L = C_{\text{LC}} = 2\text{pF}$, unless otherwise noted. (See Figure 3)

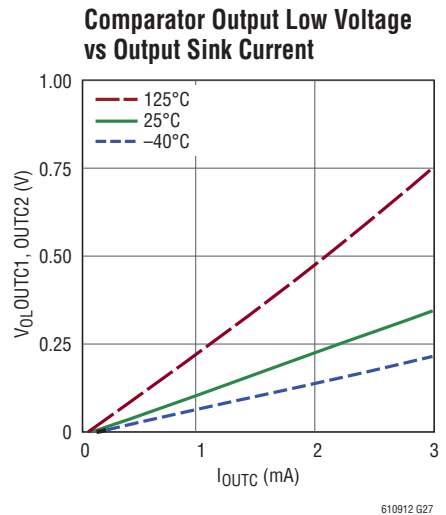
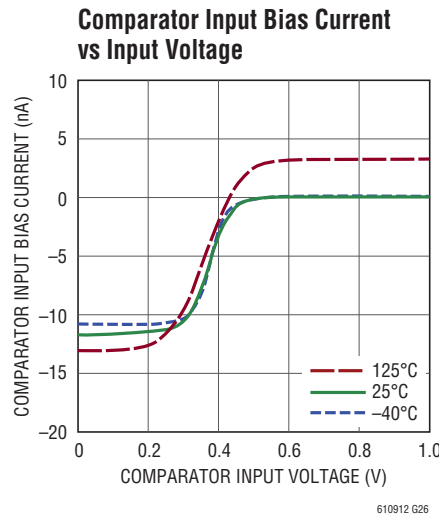
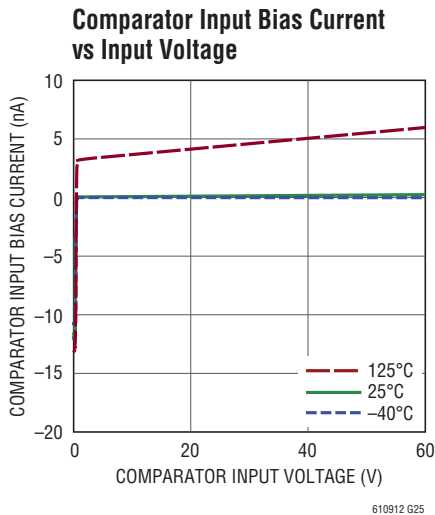
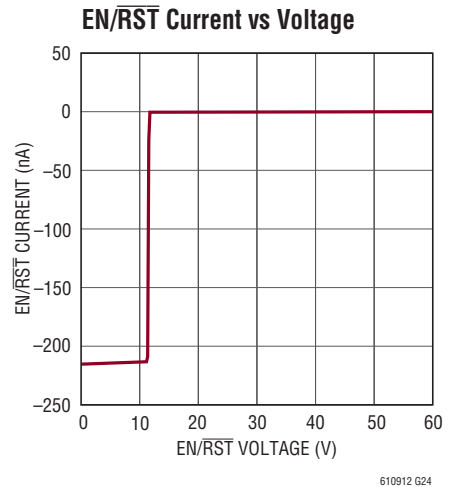
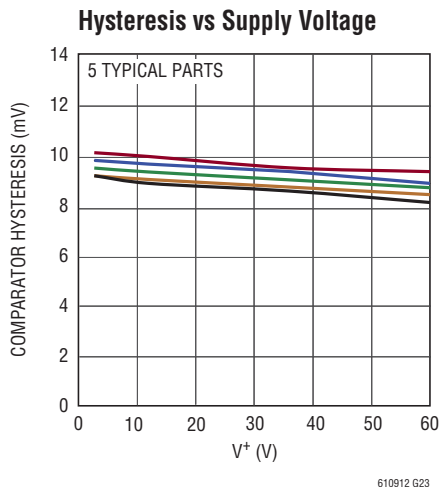
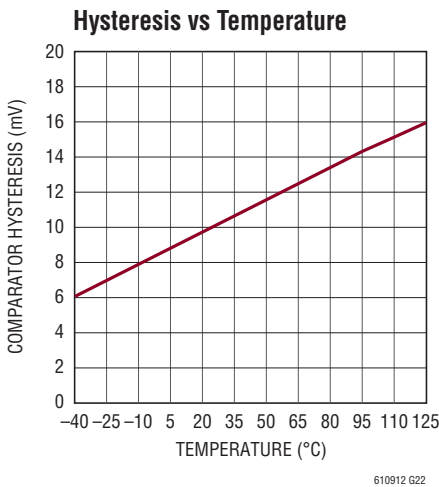
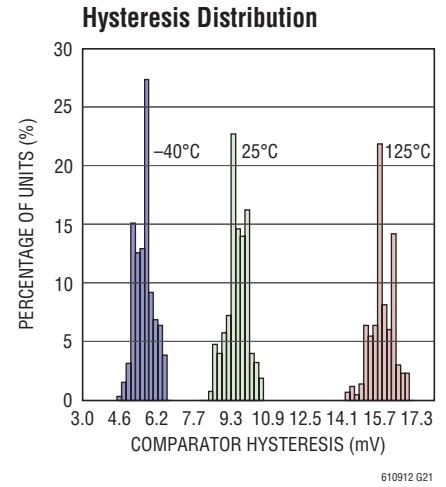
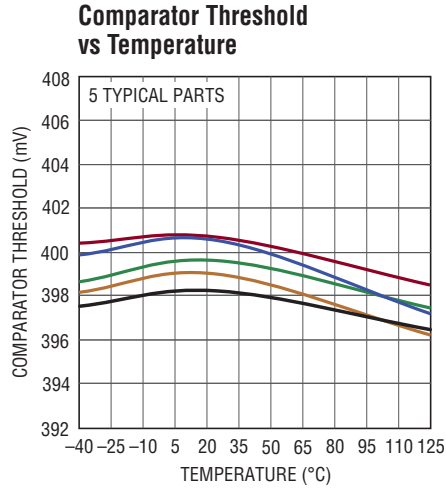
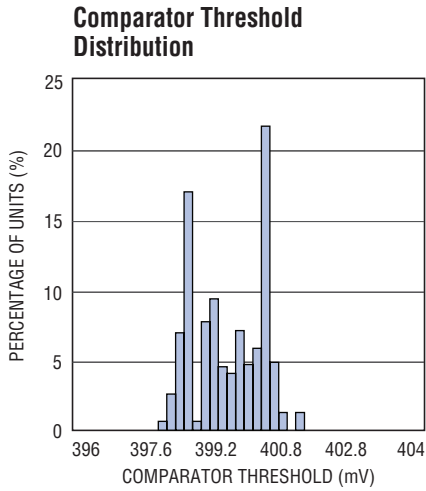

TYPICAL PERFORMANCE CHARACTERISTICS Performance characteristics taken at $T_A = 25^\circ\text{C}$, $V^+ = 12\text{V}$, $V_{\text{PULLUP}} = V^+$, $V_{\text{EN/RST}} = 2.7\text{V}$, $R_{\text{IN}} = 100\Omega$, $R_{\text{OUT}} = R1 + R2 + R3 = 10\text{k}$, gain = 100, $R_C = 25.5\text{k}$, $C_L = C_{LC} = 2\text{pF}$, unless otherwise noted. (See Figure 3)

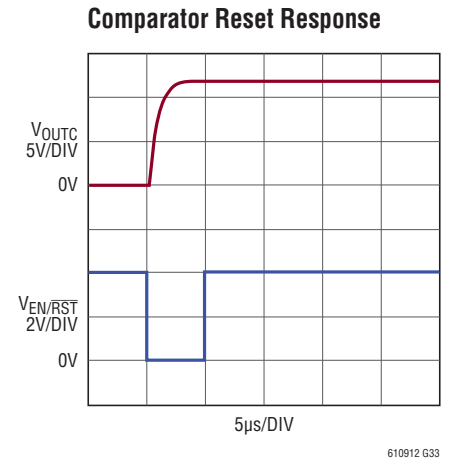
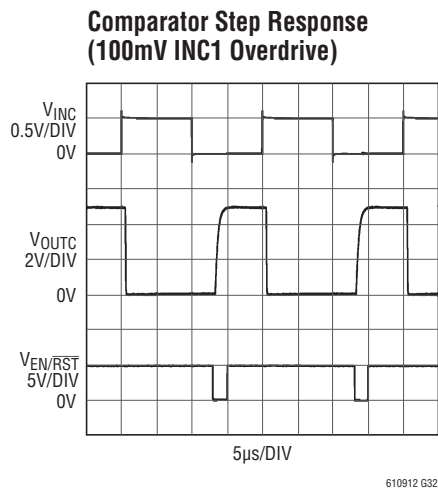
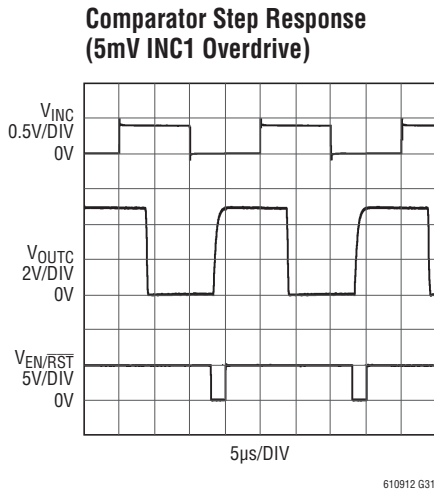
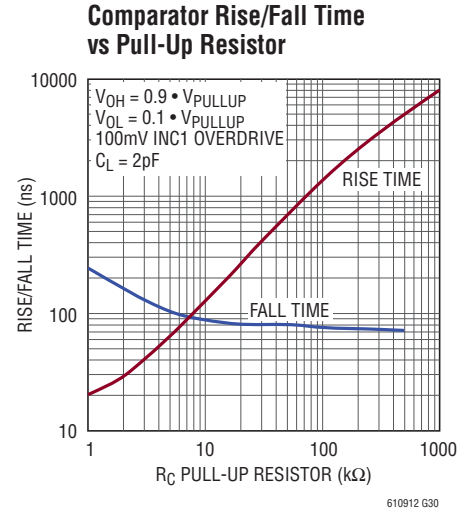
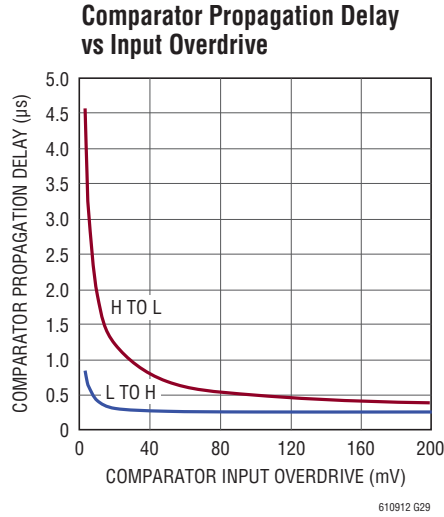
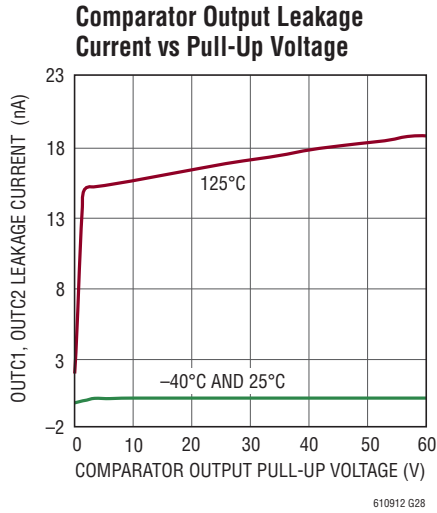

PIN FUNCTIONS

SENSELO (Pin 1): Sense Amplifier Input. This pin must be tied to the load end of the sense resistor.

EN/RST (Pin 2): Enable and Latch Reset Input. When the EN/RST pin is pulled high the LT6109 is enabled. When the EN/RST pin is pulled low for longer than typically $40\mu\text{s}$, the LT6109 will enter the shutdown mode. Pulsing this pin low for between $2\mu\text{s}$ and $15\mu\text{s}$ will reset the comparators of the LT6109.

OUTC2 (Pin 3): Open-Drain Comparator 2 Output. Off-state voltage may be as high as 60V above V^- , regardless of V^+ used.

OUTC1 (Pin 4): Open-Drain Comparator 1 Output. Off-state voltage may be as high as 60V above V^- , regardless of V^+ used.

V^- (Pin 5): Negative Supply Pin. This pin is normally connected to ground.

PIN FUNCTIONS

INC1 (Pin 6): This is the inverting input of comparator 1. The second input of this comparator is internally connected to the 400mV reference.

INC2 (Pin 7): This is the input of comparator 2. For the LT6109-1 this is the noninverting input of comparator 2. For the LT6109-2 this is the inverting input of comparator 2. The second input of each of these comparators is internally connected to the 400mV reference.

OUTA (Pin 8): Current Output of the Sense Amplifier. This pin will source a current that is equal to the sense voltage divided by the external gain setting resistor, R_{IN} .

V⁺ (Pin 9): Positive Supply Pin. The V⁺ pin can be connected directly to either side of the sense resistor, R_{SENSE} . When V⁺ is tied to the load end of the sense resistor, the SENSEHI pin can go up to 0.2V above V⁺. Supply current is drawn through this pin.

SENSEHI (Pin 10): Sense Amplifier Input. The internal sense amplifier will drive SENSEHI to the same potential as SENSELO. A resistor (typically R_{IN}) tied from supply to SENSEHI sets the output current, $I_{OUT} = V_{SENSE}/R_{IN}$, where V_{SENSE} is the voltage developed across R_{SENSE} .

BLOCK DIAGRAMS

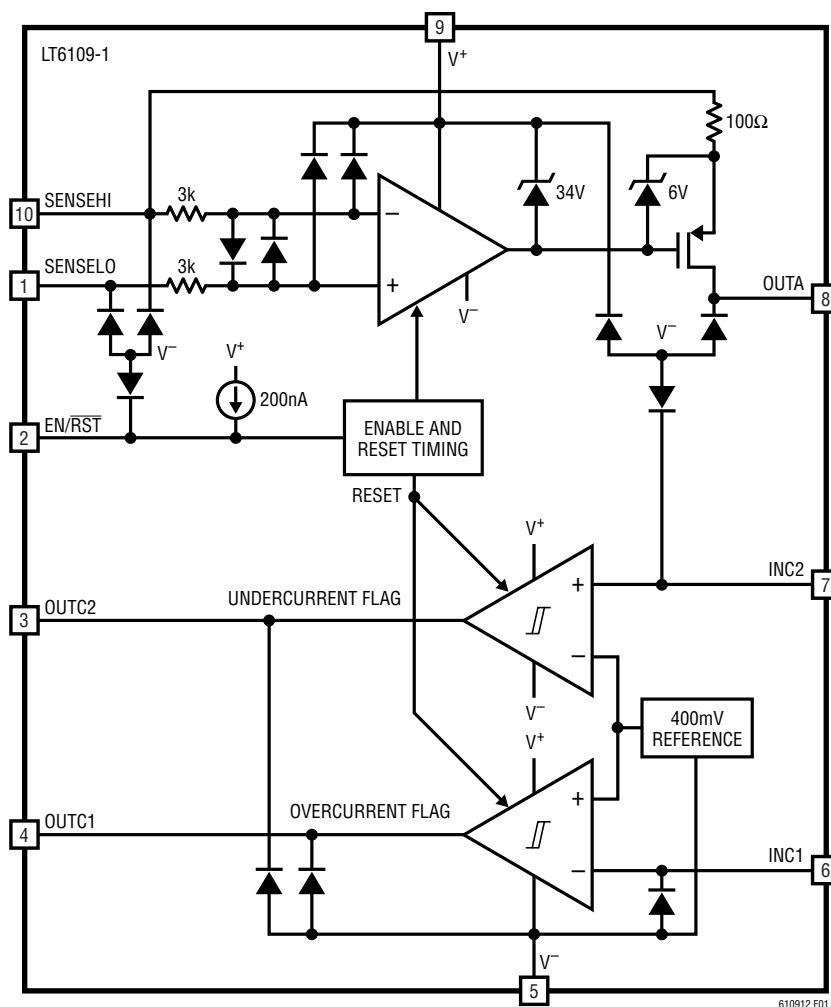

Figure 1. LT6109-1 Block Diagram (Comparators with Opposing Polarity)

BLOCK DIAGRAMS

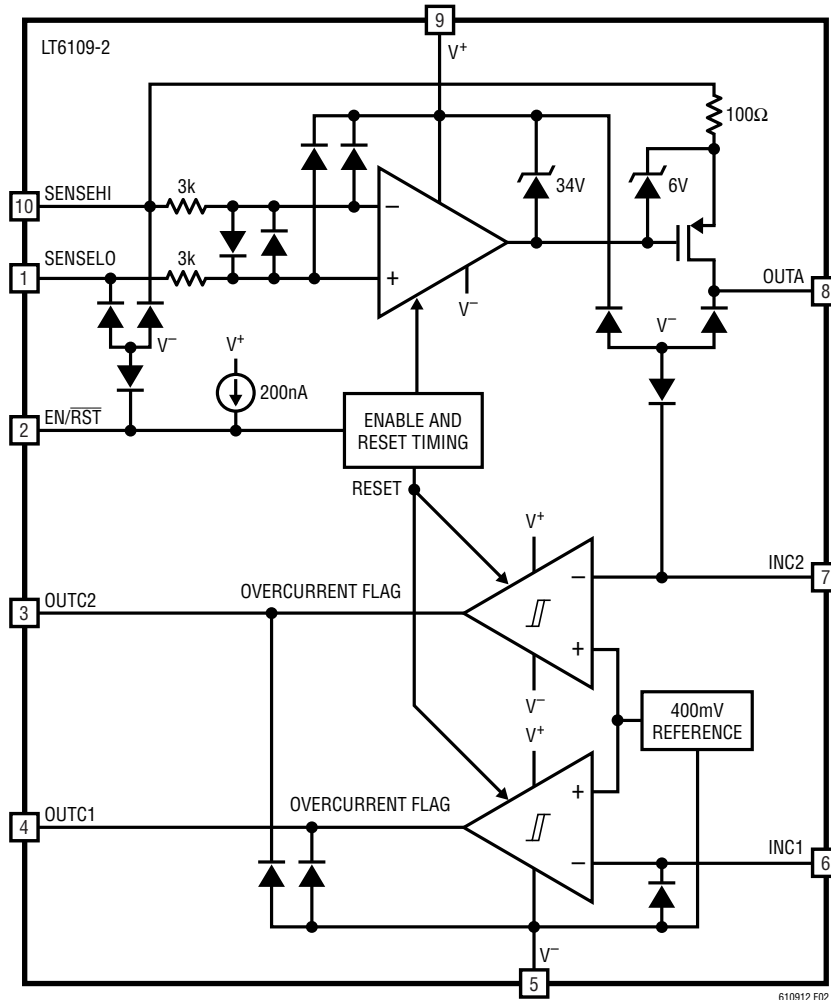

Figure 2. LT6109-2 Block Diagram (Comparators with the Same Polarity)

APPLICATIONS INFORMATION

The LT6109 high side current sense amplifier provides accurate monitoring of currents through an external sense resistor. The input sense voltage is level-shifted from the sensed power supply to a ground referenced output and is amplified by a user-selected gain to the output. The output voltage is directly proportional to the current flowing through the sense resistor.

The LT6109 comparators have a threshold set with a built-in 400mV precision reference and have 10mV of hysteresis. The open-drain outputs can be easily used to level shift to digital supplies.

Amplifier Theory of Operation

An internal sense amplifier loop forces SENSEHI to have the same potential as SENSELO as shown in Figure 3. Connecting an external resistor, R_{IN} , between SENSEHI and V_{SUPPLY} forces a potential, V_{SENSE} , across R_{IN} . A corresponding current, I_{OUTA} , equal to V_{SENSE}/R_{IN} , will flow through R_{IN} . The high impedance inputs of the sense amplifier do not load this current, so it will flow through an internal MOSFET to the output pin, OUTA.

APPLICATIONS INFORMATION

The output current can be transformed back into a voltage by adding a resistor from OUTA to V⁻ (typically ground). The output voltage is then:

$$V_{OUT} = V^- + I_{OUTA} \cdot R_{OUT}$$

where $R_{OUT} = R_1 + R_2 + R_3$ as shown in Figure 3.

Table 1. Example Gain Configurations

GAIN	R _{IN}	R _{OUT}	V _{SENSE} FOR V _{OUT} = 5V	I _{OUTA} AT V _{OUT} = 5V
20	499Ω	10k	250mV	500μA
50	200Ω	10k	100mV	500μA
100	100Ω	10k	50mV	500μA

Useful Equations

Input Voltage: $V_{SENSE} = I_{SENSE} \cdot R_{SENSE}$

Voltage Gain: $\frac{V_{OUT}}{V_{SENSE}} = \frac{R_{OUT}}{R_{IN}}$

Current Gain: $\frac{I_{OUTA}}{I_{SENSE}} = \frac{R_{SENSE}}{R_{IN}}$

Note that $V_{SENSE(MAX)}$ can be exceeded without damaging the amplifier, however, output accuracy will degrade as V_{SENSE} exceeds $V_{SENSE(MAX)}$, resulting in increased output current, I_{OUTA} .

Selection of External Current Sense Resistor

The external sense resistor, R_{SENSE} , has a significant effect on the function of a current sensing system and must be chosen with care.

First, the power dissipation in the resistor should be considered. The measured load current will cause power dissipation as well as a voltage drop in R_{SENSE} . As a result, the sense resistor should be as small as possible while still providing the input dynamic range required by the measurement. Note that the input dynamic range is the difference between the maximum input signal and the minimum accurately reproduced signal, and is limited primarily by input DC offset of the internal sense amplifier of the LT6109. To ensure the specified performance, R_{SENSE} should be small enough that V_{SENSE} does not exceed $V_{SENSE(MAX)}$ under peak load conditions. As an example, an application may require the maximum sense

voltage be 100mV. If this application is expected to draw 2A at peak load, R_{SENSE} should be set to 50mΩ.

Once the maximum R_{SENSE} value is determined, the minimum sense resistor value will be set by the resolution or dynamic range required. The minimum signal that can be accurately represented by this sense amplifier is limited by the input offset. As an example, the LT6109 has a maximum input offset of 125μV. If the minimum current is 20mA, a sense resistor of 6.25mΩ will set V_{SENSE} to 125μV. This is the same value as the input offset. A larger sense resistor will reduce the error due to offset by increasing the sense voltage for a given load current. Choosing a 50mΩ R_{SENSE} will maximize the dynamic range and provide a system that has 100mV across the sense resistor at peak load (2A), while input offset causes an error equivalent to only 2.5mA of load current.

In the previous example, the peak dissipation in R_{SENSE} is 200mW. If a 5mΩ sense resistor is employed, then the effective current error is 25mA, while the peak sense voltage is reduced to 10mV at 2A, dissipating only 20mW.

The low offset and corresponding large dynamic range of the LT6109 make it more flexible than other solutions in this respect. The 125μV maximum offset gives 72dB of dynamic range for a sense voltage that is limited to 500mV max.

Sense Resistor Connection

Kelvin connection of the SENSEHI and SENSELO inputs to the sense resistor should be used in all but the lowest power applications. Solder connections and PC board interconnections that carry high currents can cause significant error in measurement due to their relatively large resistances. One 10mm × 10mm square trace of 1oz copper is approximately 0.5mΩ. A 1mV error can be caused by as little as 2A flowing through this small interconnect. This will cause a 1% error for a full-scale V_{SENSE} of 100mV. A 10A load current in the same interconnect will cause a 5% error for the same 100mV signal. By isolating the sense traces from the high current paths, this error can be reduced by orders of magnitude. A sense resistor with integrated Kelvin sense terminals will give the best results. Figure 3 illustrates the recommended method for connecting the SENSEHI and SENSELO pins to the sense resistor.

APPLICATIONS INFORMATION

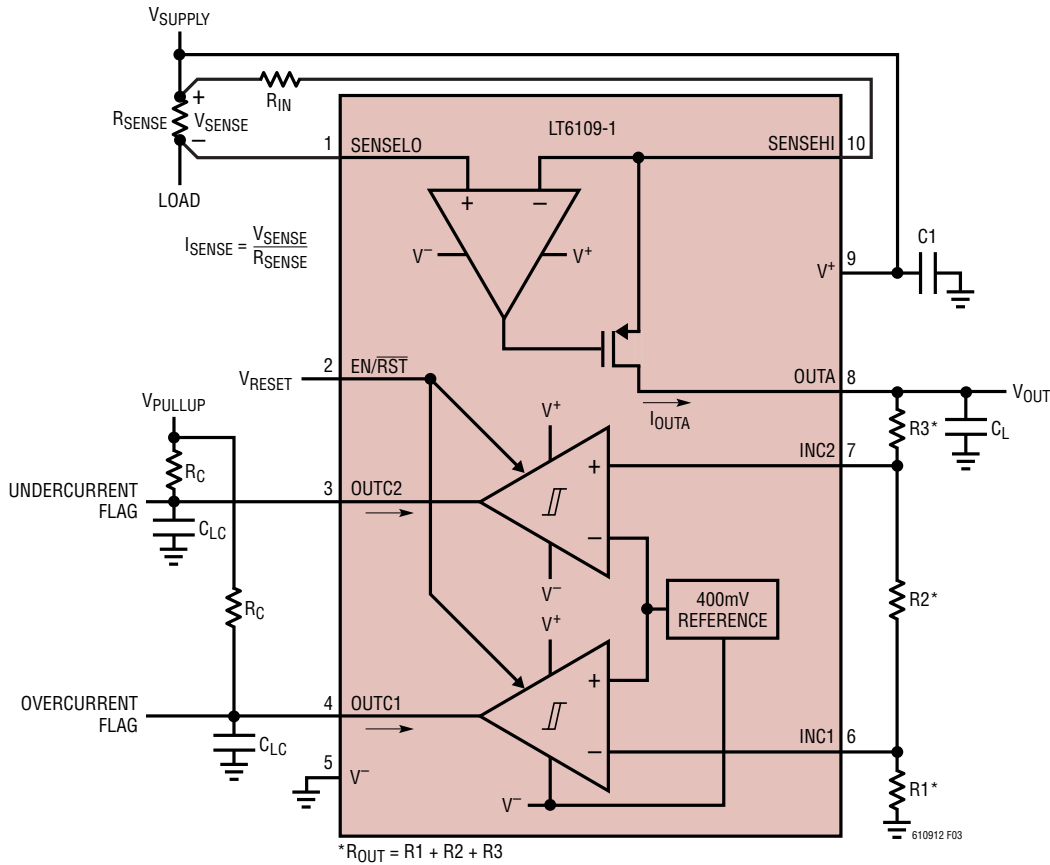

Figure 3. LT6109-1 Typical Connection

Selection of External Input Gain Resistor, R_{IN}

R_{IN} should be chosen to allow the required speed and resolution while limiting the output current to 1mA. The maximum value for R_{IN} is 1k to maintain good loop stability. For a given V_{SENSE} , larger values of R_{IN} will lower power dissipation in the LT6109 due to the reduction in I_{OUT} while smaller values of R_{IN} will result in faster response time due to the increase in I_{OUT} . If low sense currents must be resolved accurately in a system that has a very wide dynamic range, a smaller R_{IN} may be used if the maximum I_{OUTA} current is limited in another way, such as with a Schottky diode across R_{SENSE} (Figure 4). This will reduce the high current measurement accuracy by limiting the result, while increasing the low current measurement resolution.

This approach can be helpful in cases where occasional bursts of high currents can be ignored.

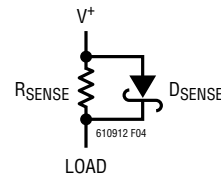

Figure 4. Shunt Diode Limits Maximum Input Voltage to Allow Better Low Input Resolution Without Overranging

Care should be taken when designing the board layout for R_{IN} , especially for small R_{IN} values. All trace and interconnect resistances will increase the effective R_{IN} value, causing a gain error.

The power dissipated in the sense resistor can create a thermal gradient across a printed circuit board and consequently a gain error if R_{IN} and R_{OUT} are placed such that they operate at different temperatures. If significant power is being dissipated in the sense resistor then care

APPLICATIONS INFORMATION

should be taken to place R_{IN} and R_{OUT} such that the gain error due to the thermal gradient is minimized.

Selection of External Output Gain Resistor, R_{OUT}

The output resistor, R_{OUT} , determines how the output current is converted to voltage. V_{OUT} is simply $I_{OUTA} \cdot R_{OUT}$. Typically, R_{OUT} is a combination of resistors configured as a resistor divider which has voltage taps going to the comparator inputs to set the comparator thresholds.

In choosing an output resistor, the maximum output voltage must first be considered. If the subsequent circuit is a buffer or ADC with limited input range, then R_{OUT} must be chosen so that $I_{OUTA(MAX)} \cdot R_{OUT}$ is less than the allowed maximum input range of this circuit.

In addition, the output impedance is determined by R_{OUT} . If another circuit is being driven, then the input impedance of that circuit must be considered. If the subsequent circuit has high enough input impedance, then almost any useful output impedance will be acceptable. However, if the subsequent circuit has relatively low input impedance, or draws spikes of current such as an ADC load, then a lower output impedance may be required to preserve the accuracy of the output. More information can be found in the Output Filtering section. As an example, if the input impedance of the driven circuit, $R_{IN(DRIVEN)}$, is 100 times R_{OUT} , then the accuracy of V_{OUT} will be reduced by 1% since:

$$\begin{aligned} V_{OUT} &= I_{OUTA} \cdot \frac{R_{OUT} \cdot R_{IN(DRIVEN)}}{R_{OUT} + R_{IN(DRIVEN)}} \\ &= I_{OUTA} \cdot R_{OUT} \cdot \frac{100}{101} = 0.99 \cdot I_{OUTA} \cdot R_{OUT} \end{aligned}$$

Amplifier Error Sources

The current sense system uses an amplifier and resistors to apply gain and level-shift the result. Consequently, the output is dependent on the characteristics of the amplifier, such as gain error and input offset, as well as the matching of the external resistors.

Ideally, the circuit output is:

$$V_{OUT} = V_{SENSE} \cdot \frac{R_{OUT}}{R_{IN}}; V_{SENSE} = R_{SENSE} \cdot I_{SENSE}$$

In this case, the only error is due to external resistor mismatch, which provides an error in gain only. However, offset voltage, input bias current and finite gain in the amplifier can cause additional errors:

Output Voltage Error, $\Delta V_{OUT(VOS)}$, Due to the Amplifier DC Offset Voltage, V_{OS}

$$\Delta V_{OUT(VOS)} = V_{OS} \cdot \frac{R_{OUT}}{R_{IN}}$$

The DC offset voltage of the amplifier adds directly to the value of the sense voltage, V_{SENSE} . As V_{SENSE} is increased, accuracy improves. This is the dominant error of the system and it limits the available dynamic range.

Output Voltage Error, $\Delta V_{OUT(IBIAS)}$, Due to the Bias Currents I_{B^+} and I_{B^-}

The amplifier bias current I_{B^+} flows into the SENSELO pin while I_{B^-} flows into the SENSEHI pin. The error due to I_B is the following:

$$\Delta V_{OUT(IBIAS)} = R_{OUT} \left(I_{B^+} \cdot \frac{R_{SENSE}}{R_{IN}} - I_{B^-} \right)$$

Since $I_{B^+} \approx I_{B^-} = I_{BIAS}$, if $R_{SENSE} \ll R_{IN}$ then,

$$\Delta V_{OUT(IBIAS)} = -R_{OUT} (I_{BIAS})$$

It is useful to refer the error to the input:

$$\Delta V_{IN(IBIAS)} = -R_{IN} (I_{BIAS})$$

For instance, if I_{BIAS} is 100nA and R_{IN} is 1k, the input referred error is 100 μ V. This error becomes less significant as the value of R_{IN} decreases. The bias current error can be reduced if an external resistor, R_{IN^+} , is connected as shown in Figure 5, the error is then reduced to:

$$V_{OUT(IBIAS)} = \pm R_{OUT} \cdot I_{OS}; I_{OS} = I_{B^+} - I_{B^-}$$

Minimizing low current errors will maximize the dynamic range of the circuit.

APPLICATIONS INFORMATION

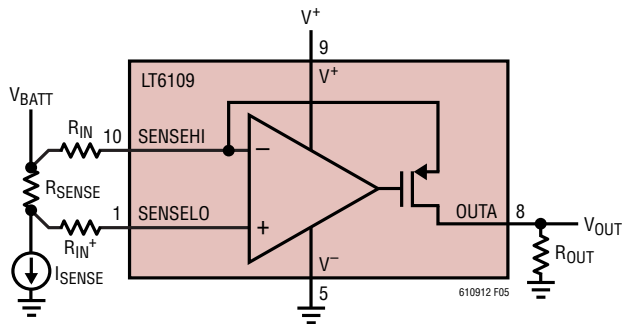

Figure 5. R_{IN+} Reduces Error Due to I_B

Output Voltage Error, $\Delta V_{OUT(GAIN ERROR)}$, Due to External Resistors

The LT6109 exhibits a very low gain error. As a result, the gain error is only significant when low tolerance resistors are used to set the gain. Note the gain error is systematically negative. For instance, if 0.1% resistors are used for R_{IN} and R_{OUT} then the resulting worst-case gain error is -0.4% with $R_{IN} = 100\Omega$. Figure 6 is a graph of the maximum gain error which can be expected versus the external resistor tolerance.

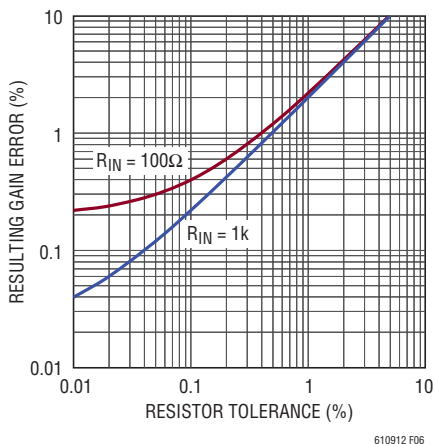

Figure 6. Gain Error vs Resistor Tolerance

Output Current Limitations Due to Power Dissipation

The LT6109 can deliver a continuous current of 1mA to the OUTA pin. This current flows through R_{IN} and enters the current sense amplifier via the SENSEHI pin. The power dissipated in the LT6109 due to the output signal is:

$$P_{OUT} = (V_{SENSEHI} - V_{OUTA}) \cdot I_{OUTA}$$

$$\text{Since } V_{SENSEHI} \approx V^+, P_{OUTA} \approx (V^+ - V_{OUTA}) \cdot I_{OUTA}$$

There is also power dissipated due to the quiescent power supply current:

$$P_S = I_S \cdot V^+$$

The comparator output current flows into the comparator output pin and out of the V^- pin. The power dissipated in the LT6109 due to each comparator is often insignificant and can be calculated as follows:

$$P_{OUTC1,C2} = (V_{OUTC1,C2} - V^-) \cdot I_{OUTC1,C2}$$

The total power dissipated is the sum of these dissipations:

$$P_{TOTAL} = P_{OUTA} + P_{OUTC1} + P_{OUTC2} + P_S$$

At maximum supply and maximum output currents, the total power dissipation can exceed 100mW. This will cause significant heating of the LT6109 die. In order to prevent damage to the LT6109, the maximum expected dissipation in each application should be calculated. This number can be multiplied by the θ_{JA} value, 160°C/W , to find the maximum expected die temperature. Proper heat sinking and thermal relief should be used to ensure that the die temperature does not exceed the maximum rating.

Output Filtering

The AC output voltage, V_{OUT} , is simply $I_{OUTA} \cdot Z_{OUT}$. This makes filtering straightforward. Any circuit may be used which generates the required Z_{OUT} to get the desired filter response. For example, a capacitor in parallel with R_{OUT} will give a lowpass response. This will reduce noise at the output, and may also be useful as a charge reservoir to keep the output steady while driving a switching circuit such as a MUX or ADC. This output capacitor in parallel with R_{OUT} will create an output pole at:

$$f_{-3dB} = \frac{1}{2 \cdot \pi \cdot R_{OUT} \cdot C_L}$$

SENSELO, SENSEHI Range

The difference between V_{BATT} (see Figure 7) and V^+ , as well as the maximum value of V_{SENSE} , must be considered to ensure that the SENSELO pin doesn't exceed the range listed in the Electrical Characteristics table. The SENSELO and SENSEHI pins of the LT6109 can function from 0.2V

APPLICATIONS INFORMATION

above the positive supply to 33V below it. These operating voltages are limited by internal diode clamps shown in Figures 1 and 2. On supplies less than 35.5V, the lower range is limited by $V^- + 2.5V$. This allows the monitored supply, V_{BATT} , to be separate from the LT6109 positive supply as shown in Figure 7. Figure 8 shows the range of operating voltages for the SENSELO and SENSEHI inputs, for different supply voltage inputs (V^+). The SENSELO and SENSEHI range has been designed to allow the LT6109 to monitor its own supply current (in addition to the load), as long as V_{SENSE} is less than 200mV. This is shown in Figure 9.

Minimum Output Voltage

The output of the LT6109 current sense amplifier can produce a non-zero output voltage when the sense voltage is zero. This is a result of the sense amplifier V_{OS} being forced across R_{IN} as discussed in the Output Voltage Error, $\Delta V_{OUT(V_{OS})}$ section. Figure 10 shows the effect of the input offset voltage on the transfer function for parts at the V_{OS} limits. With a negative offset voltage, zero input sense voltage produces an output voltage. With a positive offset voltage, the output voltage is zero until the input sense voltage exceeds the input offset voltage. Neglecting V_{OS} , the output circuit is not limited by saturation of pull-down circuitry and can reach 0V.

Response Time

The LT6109 amplifier is designed to exhibit fast response to inputs for the purpose of circuit protection or current monitoring. This response time will be affected by the external components in two ways, delay and speed.

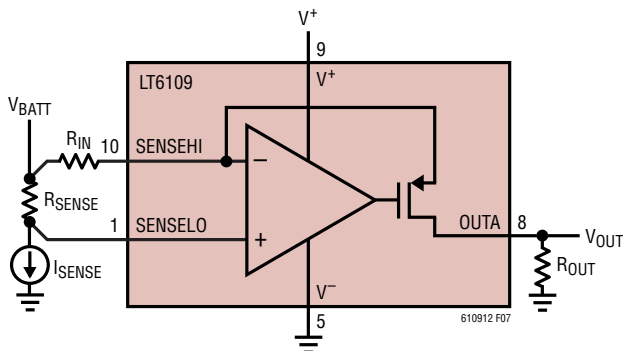

Figure 7. V^+ Powered Separately from Load Supply (V_{BATT})

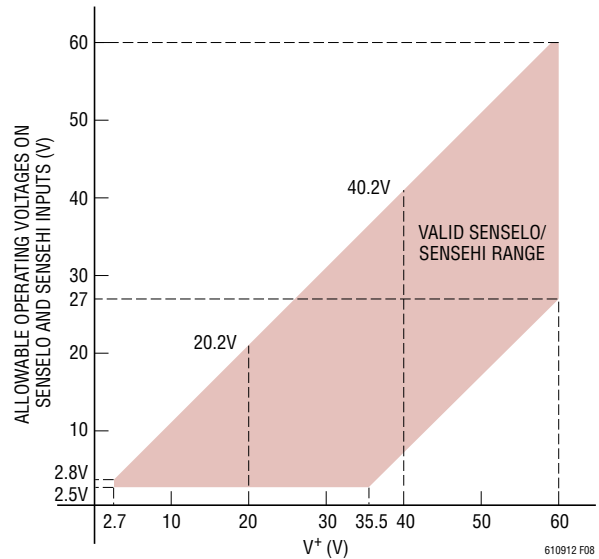

Figure 8. Allowable SENSELO, SENSEHI Voltage Range

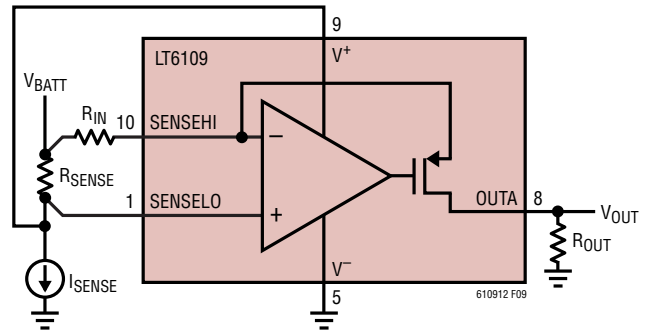

Figure 9. LT6109 Supply Current Monitored with Load

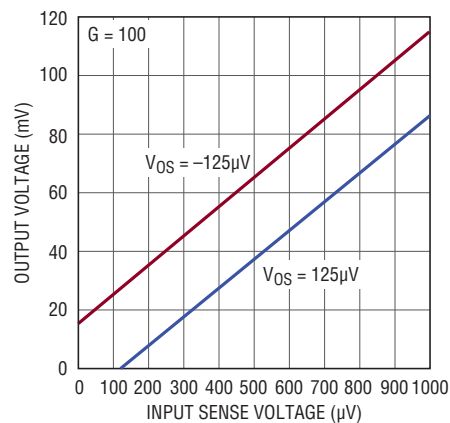

Figure 10. Amplifier Output Voltage vs Input Sense Voltage

APPLICATIONS INFORMATION

If the output current is very low and an input transient occurs, there may be an increased delay before the output voltage begins to change. The Typical Performance Characteristics show that this delay is short and it can be improved by increasing the minimum output current, either by increasing R_{SENSE} or decreasing R_{IN} . Note that the Typical Performance Characteristics are labeled with respect to the initial sense voltage.

The speed is also affected by the external components. Using a larger R_{OUT} will decrease the response time, since $V_{OUT} = I_{OUTA} \cdot Z_{OUT}$ where Z_{OUT} is the parallel combination of R_{OUT} and any parasitic and/or load capacitance. Note that reducing R_{IN} or increasing R_{OUT} will both have the effect of increasing the voltage gain of the circuit. If the output capacitance is limiting the speed of the system, R_{IN} and R_{OUT} can be decreased together in order to maintain the desired gain and provide more current to charge the output capacitance.

The response time of the comparators is the sum of the propagation delay and the fall time. The propagation delay is a function of the overdrive voltage on the input of the comparators. A larger overdrive will result in a lower propagation delay. This helps achieve a fast system response time to fault events. The fall time is affected by the load on the output of the comparator as well as the pull-up voltage.

The LT6109 amplifier has a typical response time of 500ns and the comparators have a typical response time of 500ns. When configured as a system, the amplifier output drives the comparator input causing a total system response time which is typically greater than that implied by the individually specified response times. This is due to the overdrive on the comparator input being determined by the speed of the amplifier output.

Internal Reference and Comparators

The integrated precision reference and comparators combined with the high precision current sense allow for rapid and easy detection of abnormal load currents. This is often critical in systems that require high levels of safety and reliability. The LT6109 comparators are optimized for fault detection and are designed with latching outputs. Latching outputs prevent faults from clearing themselves and

require a separate system or user to reset the outputs. In applications where the comparator output can intervene and disconnect loads from the supply, latched outputs are required to avoid oscillation. Latching outputs are also useful for detecting problems that are intermittent. The comparator outputs on the LT6109 are always latching and there is no way to disable this feature.

Each of the comparators has one input available externally, with the two versions of the part differing by the polarity of those available inputs. The other comparator inputs are connected internally to the 400mV precision reference. The input threshold (the voltage which causes the output to transition from high to low) is designed to be equal to that of the reference. The reference voltage is established with respect to the device V^- connection.

Comparator Inputs

The comparator inputs can swing from V^- to 60V regardless of the supply voltage used. The input current for inputs well above the threshold is just a few pAs. With decreasing input voltage, a small bias current begins to be drawn out of the input near the threshold, reaching 50nA max when at ground potential. Note that this change in input bias current can cause a small nonlinearity in the OUTA transfer function if the comparator inputs are coupled to the amplifier output with a voltage divider. For example, if the maximum comparator input current is 50nA, and the resistance seen looking out of the comparator input is 1k, then a change in output voltage of 50 μ V will be seen on the analog output when the comparator input voltage passes through its threshold. If both comparator inputs are connected to the output then they must both be considered.

Setting Comparator Thresholds

The comparators have an internal precision 400mV reference. In order to set the trip points of the LT6109-1 comparators, the output currents, I_{OVER} and I_{UNDER} , as well as the maximum output current, I_{MAX} , must be calculated:

$$I_{OVER} = \frac{V_{SENSE(OVER)}}{R_{IN}}, \quad I_{UNDER} = \frac{V_{SENSE(UNDER)}}{R_{IN}},$$

$$I_{MAX} = \frac{V_{SENSE(MAX)}}{R_{IN}}$$

APPLICATIONS INFORMATION

where I_{OVER} and I_{UNDER} are the over and under currents through the sense resistor which cause the comparators to trip. I_{MAX} is the maximum current through the sense resistor.

Depending on the desired maximum amplifier output voltage (V_{MAX}) the three output resistors, R1, R2 and R3, can be configured in two ways. If:

$$V_{MAX} > \left[\frac{400mV}{I_{OVER}} + \frac{400mV - I_{UNDER}(R1)}{I_{UNDER}} \right] I_{MAX}$$

then use the configuration shown in Figure 3. The desired trip points and full-scale analog output voltage for the circuit in Figure 3 can then be achieved using the following equations:

$$R1 = \frac{400mV}{I_{OVER}}$$

$$R2 = \frac{400mV - I_{UNDER}(R1)}{I_{UNDER}}$$

$$R3 = \frac{V_{MAX} - I_{MAX}(R1 + R2)}{I_{MAX}}$$

If:

$$V_{MAX} < \left[\frac{400mV}{I_{OVER}} + \frac{400mV - I_{UNDER}(R1)}{I_{UNDER}} \right] I_{MAX}$$

then use the configuration shown in Figure 11.

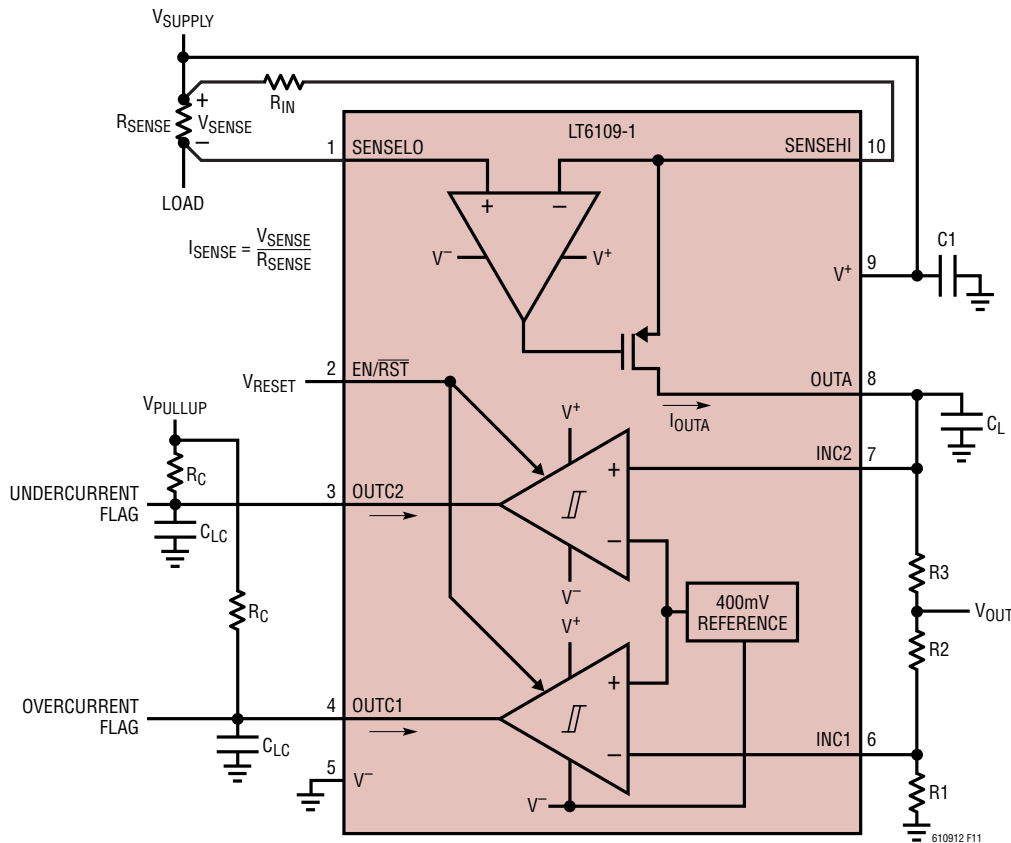

Figure 11. Typical Configuration with Alternative R_{OUT} Configuration

APPLICATIONS INFORMATION

The desired trip points and full-scale analog output voltage for the circuit in Figure 13 can be achieved as follows:

$$R1 = \frac{400\text{mV}}{I_{\text{OVER}}}$$

$$R2 = \frac{V_{\text{MAX}} - I_{\text{MAX}}(R1)}{I_{\text{MAX}}}$$

$$R3 = \frac{400\text{mV} - I_{\text{UNDER}}(R1 + R2)}{I_{\text{UNDER}}}$$

Trip points for the LT6109-2 can be set by replacing I_{UNDER} with a second overcurrent, I_{OVER2} .

Hysteresis

Each comparator has a typical built-in hysteresis of 10mV to simplify design, ensure stable operation in the presence of noise at the inputs, and to reject supply noise that might be induced by state change load transients. The hysteresis is designed such that the threshold voltage is altered when the output is transitioning from low to high as is shown in Figure 12.

External positive feedback circuitry can be employed to increase the effective hysteresis if desired, but such circuitry will have an effect on both the rising and fall-

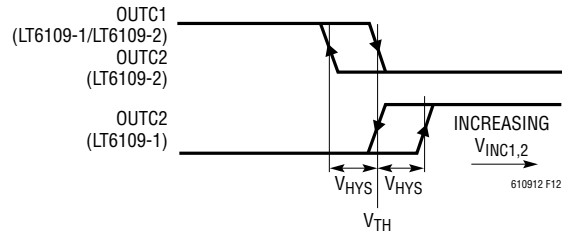

Figure 12. Comparator Output Transfer Characteristics

ing input thresholds, V_{TH} (the actual internal threshold remains unaffected).

Figure 13 shows how to add additional hysteresis to a noninverting comparator.

$R6$ can be calculated from the extra hysteresis being added, $V_{\text{HYS(EXTRA)}}$ and the amplifier output current which you want to cause the comparator output to trip, I_{UNDER} . Note that the hysteresis being added, $V_{\text{HYS(EXTRA)}}$, is in addition to the typical 10mV of built-in hysteresis.

$$R6 = \frac{400\text{mV} - V_{\text{HYS(EXTRA)}}}{I_{\text{UNDER}}}$$

$R1$ should be chosen such that $R1 \gg R6$ so that V_{OUTA} does not change significantly when the comparator trips.

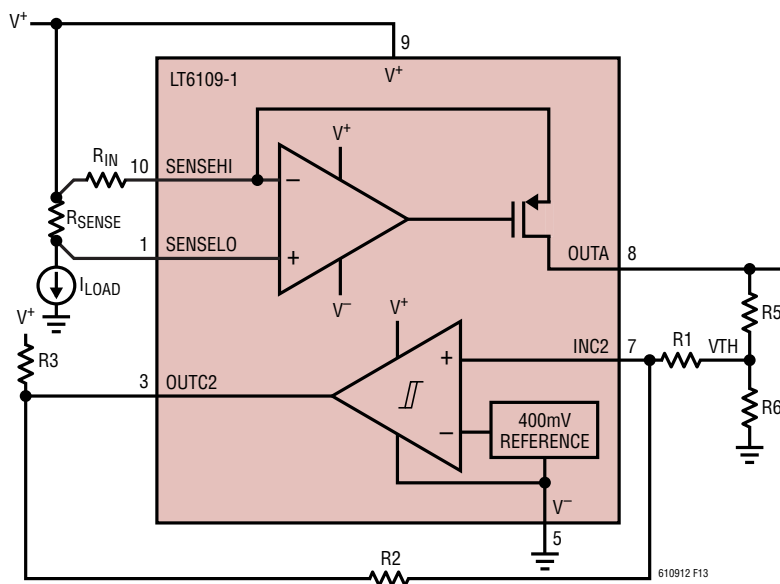

Figure 13. Noninverting Comparator with Added Hysteresis

APPLICATIONS INFORMATION

R3 should be chosen to allow sufficient V_{OL} and comparator output rise time due to capacitive loading.

R2 can be calculated:

$$R2 = \frac{R1 \cdot (V^+ - 400\text{mV}) - (V_{\text{HYS(EXTRA)}} \cdot R3)}{V_{\text{HYS(EXTRA)}}$$

For very large values of R2 PCB related leakage may become an issue. A tee network can be implemented to reduce the required resistor values.

The approximate total hysteresis will be:

$$V_{\text{HYS}} = 10\text{mV} + R1 \cdot \left(\frac{V^+ - 400\text{mV}}{R2 + R3} \right)$$

For example, to achieve $I_{\text{UNDER}} = 100\mu\text{A}$ with 50mV of total hysteresis, $R6 = 3.57\text{k}$. Choosing $R1 = 35.7\text{k}$, $R3 = 10\text{k}$ and $V^+ = 5\text{V}$ results in $R2 = 4.12\text{M}$.

The analog output voltage will also be affected when the comparator trips due to the current injected into R6 by the positive feedback. Because of this, it is desirable to have $(R1 + R2 + R3) \gg R6$. The maximum V_{OUTA} error caused by this can be calculated as:

$$\Delta V_{\text{OUTA}} = V^+ \cdot \left(\frac{R6}{R1 + R2 + R3 + R6} \right)$$

In the previous example, this is an error of 4.3mV at the output of the amplifier or 43μV at the input of the amplifier assuming a gain of 100.

When using the comparators with their inputs decoupled from the output of the amplifier, they may be driven directly by a voltage source. It is useful to know the threshold voltage equations with the additional hysteresis. The input falling edge threshold which causes the output to transition from high to low is:

$$V_{\text{TH(F)}} = 400\text{mV} \cdot R1 \cdot \left(\frac{1}{R1} + \frac{1}{R2 + R3} \right) - \left(\frac{V^+ \cdot R1}{R2 + R3} \right)$$

The input rising edge threshold which causes the output to transition from low to high is:

$$V_{\text{TH(R)}} = 410\text{mV} \cdot R1 \cdot \left(\frac{1}{R1} + \frac{1}{R2} \right)$$

Figure 14 shows how to add additional hysteresis to an inverting comparator.

R7 can be calculated from the amplifier output current which is required to cause the comparator output to trip, I_{OVER} .

$$R7 = \frac{400\text{mV}}{I_{\text{OVER}}}, \text{ Assuming } (R1 + R2) \gg R7$$

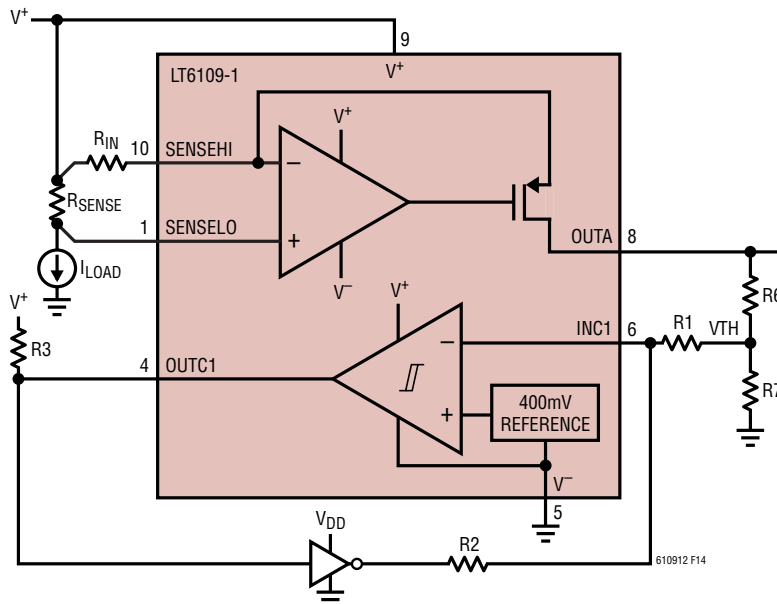

Figure 14. Inverting Comparator with Added Hysteresis

APPLICATIONS INFORMATION

To ensure $(R1 + R2) \gg R7$, R1 should be chosen such that $R1 \gg R7$ so that V_{OUTA} does not change significantly when the comparator trips.

R3 should be chosen to allow sufficient V_{OL} and comparator output rise time due to capacitive loading.

R2 can be calculated:

$$R2 = R1 \cdot \left(\frac{V_{DD} - 390\text{mV}}{V_{HYS(EXTRA)}} \right)$$

Note that the hysteresis being added, $V_{HYS(EXTRA)}$, is in addition to the typical 10mV of built-in hysteresis. For very large values of R2 PCB related leakage may become an issue. A tee network can be implemented to reduce the required resistor values.

The approximate total hysteresis is:

$$V_{HYS} = 10\text{mV} + R1 \cdot \left(\frac{V_{DD} - 390\text{mV}}{R2} \right)$$

For example, to achieve $I_{OVER} = 900\mu\text{A}$ with 50mV of total hysteresis, $R7 = 442\Omega$. Choosing $R1 = 4.42\text{k}$, $R3 = 10\text{k}$ and $V_{DD} = 5\text{V}$ results in $R2 = 513\text{k}$.

The analog output voltage will also be affected when the comparator trips due to the current injected into R7 by the positive feedback. Because of this, it is desirable to have $(R1 + R2) \gg R7$. The maximum V_{OUTA} error caused by this can be calculated as:

$$\Delta V_{OUTA} = V_{DD} \cdot \left(\frac{R7}{R1 + R2 + R7} \right)$$

In the previous example, this is an error of 4.3mV at the output of the amplifier or $43\mu\text{V}$ at the input of the amplifier assuming a gain of 100.

When using the comparators with their inputs decoupled from the output of the amplifier they may be driven directly by a voltage source. It is useful to know the threshold voltage equations with additional hysteresis. The input rising edge threshold which causes the output to transition from high to low is:

$$V_{TH(R)} = 400\text{mV} \cdot \left(1 + \frac{R1}{R2} \right)$$

The input falling edge threshold which causes the output to transition from low to high is:

$$V_{TH(F)} = 390\text{mV} \cdot \left(1 + \frac{R1}{R2} \right) - V_{DD} \left(\frac{R1}{R2} \right)$$

Comparator Outputs

The comparator outputs can maintain a logic low level of 150mV while sinking 500 μA . The outputs can sink higher currents at elevated V_{OL} levels as shown in the Typical Performance Characteristics. Load currents are conducted to the V^- pin. The output off-state voltage may range between 0V and 60V with respect to V^- , regardless of the supply voltage used. As with any open-drain device, the outputs may be tied together to implement wire-OR logic functions. The LT6109-1 can be used as a single-output window comparator in this way.

EN/ $\overline{\text{RST}}$ Pin

The EN/ $\overline{\text{RST}}$ pin performs the two functions of resetting the latch on the comparators as well as shutting down the LT6109. After powering on the LT6109, the comparators must be reset in order to guarantee a valid state at their outputs.

Applying a pulse to the EN/ $\overline{\text{RST}}$ pin will reset the comparators from their tripped state as long as the input on the comparator is below the threshold and hysteresis for an inverting comparator or above the threshold and hysteresis for a noninverting comparator. For example, if V_{INC1} is pulled higher than 400mV and latches the comparator, a reset pulse will not reset that comparator unless its input is held below the threshold by a voltage greater than the 10mV typical hysteresis. The comparator outputs typically unlatch in 0.5 μs with 2pF of capacitive load. Increased capacitive loading will cause increased unlatch time.

Figure 15 shows the reset functionality of the EN/ $\overline{\text{RST}}$ pin. The width of the pulse applied to reset the comparators must be greater than $t_{RPW(MIN)}$ (2 μs) but less than $t_{RPW(MAX)}$ (15 μs). Applying a pulse that is longer than 40 μs typically (or tying the pin low) will cause the part to enter shutdown. Once the part has entered shutdown, the supply current will be reduced to 3 μA typically and the amplifier, comparators and reference will cease to function

APPLICATIONS INFORMATION

until the $\overline{\text{EN/RST}}$ pin is transitioned high. When the part is disabled, both the amplifier and comparator outputs are high impedance.

When the $\overline{\text{EN/RST}}$ pin is transitioned from low to high to enable the part, the amplifier output PMOS can turn on momentarily causing typically 1mA of current to flow into the SENSEHI pin and out of the OUTA pin. Once the amplifier is fully on, the output will go to the correct current. Figure 16 shows this behavior and the impact it has

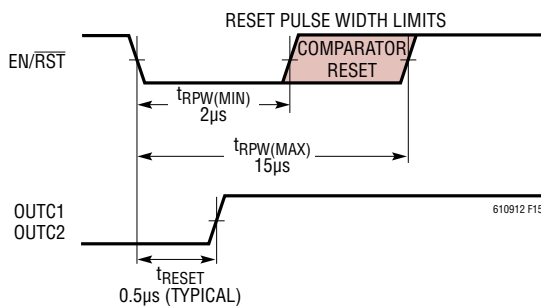

Figure 15. Comparator Reset Functionality

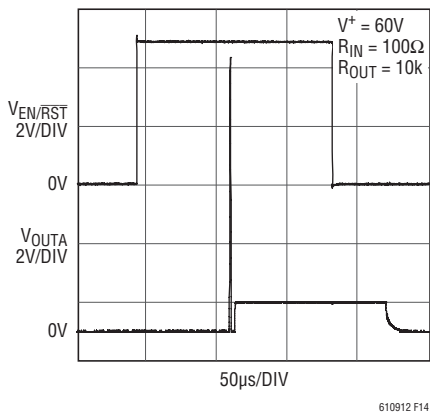

Figure 16. Amplifier Enable Response

on V_{OUTA} . Circuitry connected to OUTA can be protected from these transients by using an external diode to clamp V_{OUTA} or a capacitor to filter V_{OUTA} .

Power Up

After powering on the LT6109, the comparators must be reset in order to guarantee a valid state at their outputs. Fast supply ramps may cause a supply current transient during start-up as shown in the Typical Performance Characteristics. This current can be lowered by reducing the edge speed of the supply.

Reverse-Supply Protection

The LT6109 is not protected internally from external reversal of supply polarity. To prevent damage that may occur during this condition, a Schottky diode should be added in series with V^- (Figure 17). This will limit the reverse current through the LT6109. Note that this diode will limit the low voltage operation of the LT6109 by effectively reducing the supply voltage to the part by V_D .

Also note that the comparator reference, comparator output and $\overline{\text{EN/RST}}$ input are referenced to the V^- pin. In order to preserve the precision of the reference and to avoid driving the comparator inputs below V^- , R2 must connect to the V^- pin. This will shift the amplifier output voltage up by V_D . V_{OUTA} can be accurately measured differentially across R1 and R2. The comparator output low voltage will also be shifted up by V_D . The $\overline{\text{EN/RST}}$ pin threshold is referenced to the V^- pin. In order to provide valid input levels to the LT6109 and avoid driving $\overline{\text{EN/RST}}$ below V^- the negative supply of the driving circuit should be tied to V^- .

TYPICAL APPLICATIONS

MCU Interfacing with Hardware Interrupts

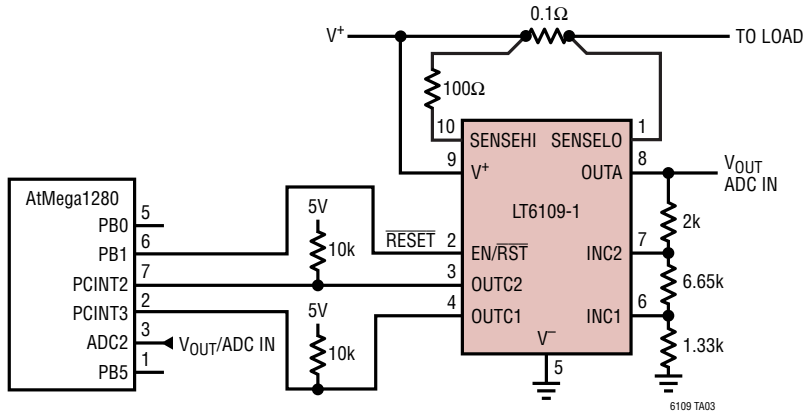

Example:

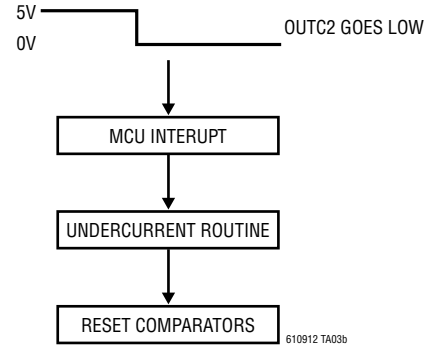

The comparators are set to have a 50mA undercurrent threshold and a 300mA overcurrent threshold. The MCU

will receive the comparator outputs as hardware interrupts and immediately run an appropriate fault routine.

Simplified DC Motor Torque Control

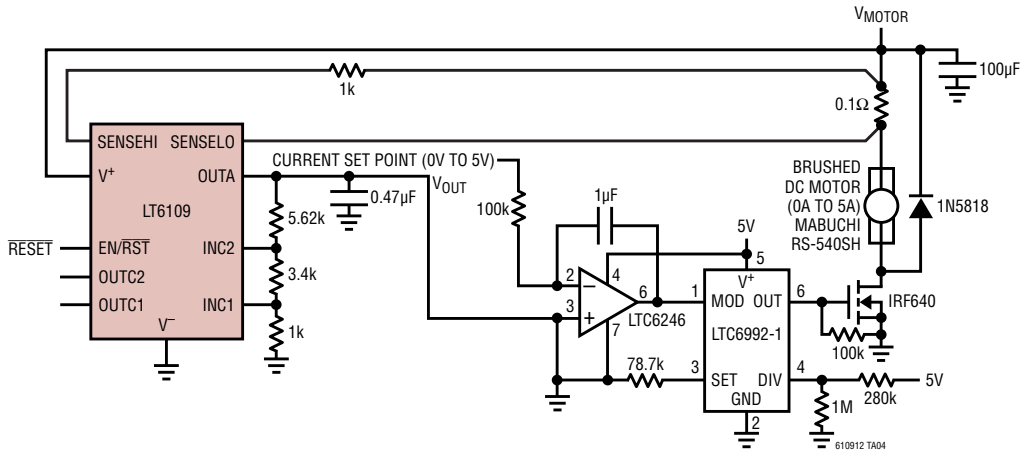

The figure shows a simplified DC motor control circuit. The circuit controls motor current, which is proportional to motor torque; the LT6109 is used to provide current

feedback to a difference amplifier that controls the current in the motor. The LTC[®]6992 is used to convert the output of the difference amp to the motor's PWM control signal.

TYPICAL APPLICATIONS

Precision Power-On Reset Using a TimerBlox® Circuit

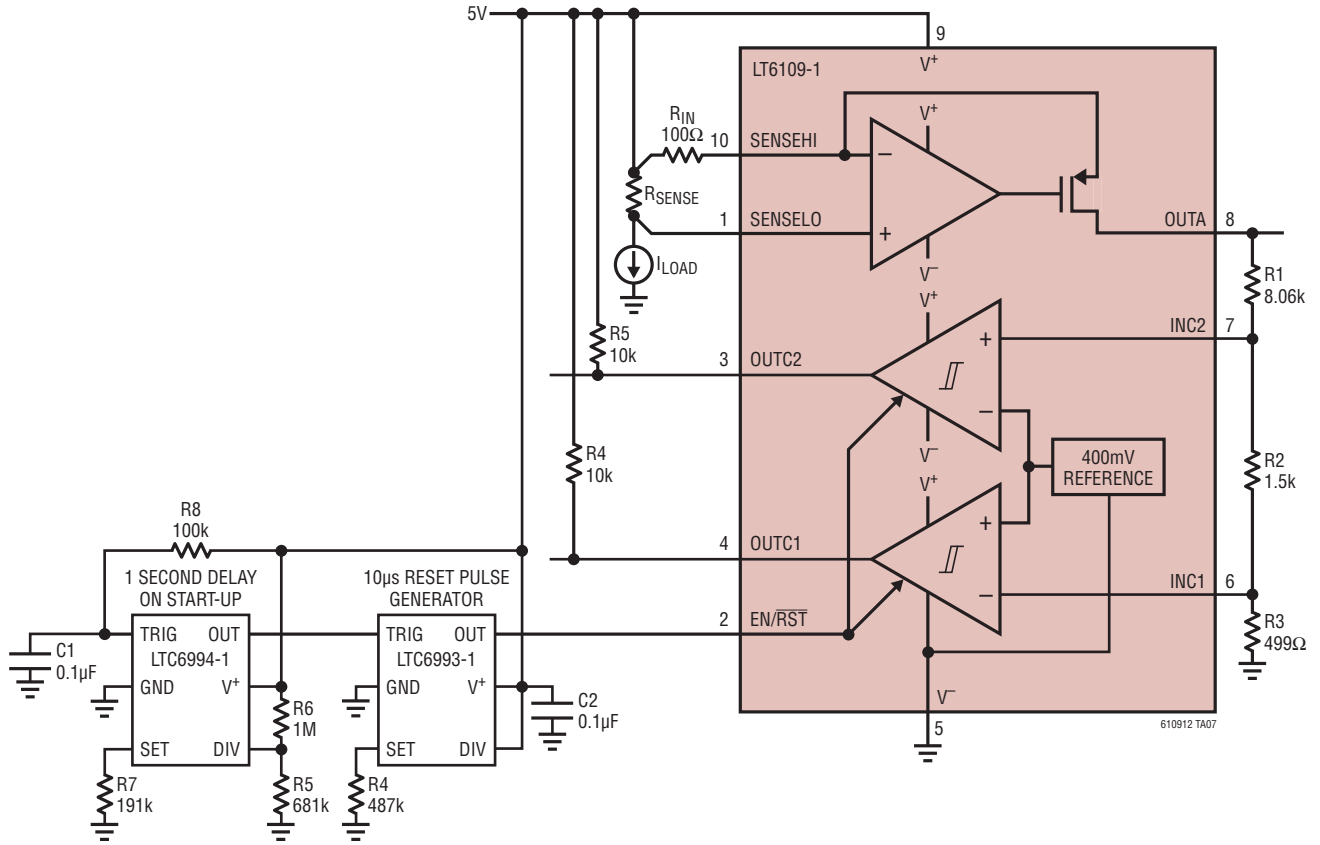

PACKAGE DESCRIPTION

MS Package
10-Lead Plastic MSOP
 (Reference LTC DWG # 05-08-1661 Rev E)

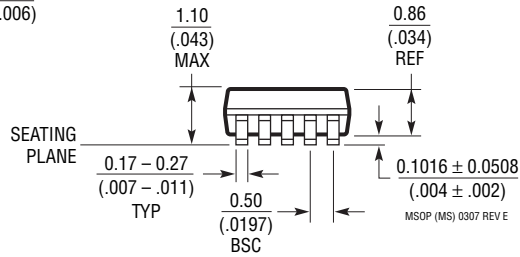
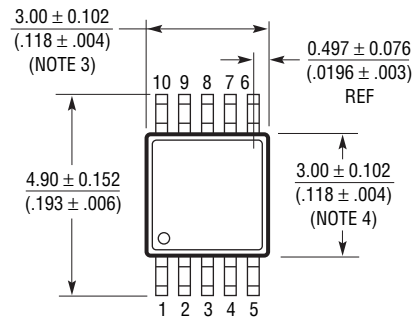
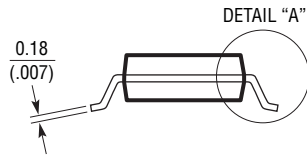
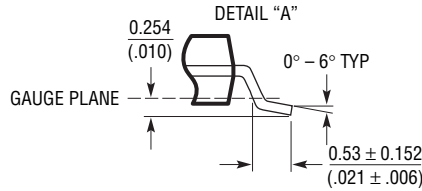
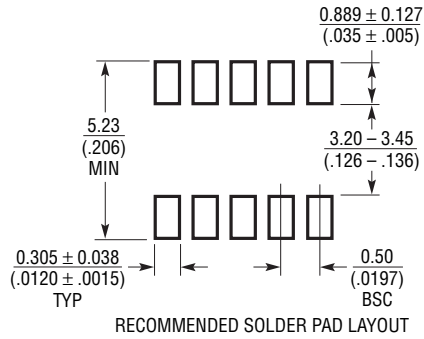

NOTE:

1. DIMENSIONS IN MILLIMETER/(INCH)
2. DRAWING NOT TO SCALE
3. DIMENSION DOES NOT INCLUDE MOLD FLASH, PROTRUSIONS OR GATE BURRS.
 MOLD FLASH, PROTRUSIONS OR GATE BURRS SHALL NOT EXCEED 0.152mm (.006") PER SIDE
4. DIMENSION DOES NOT INCLUDE INTERLEAD FLASH OR PROTRUSIONS.
 INTERLEAD FLASH OR PROTRUSIONS SHALL NOT EXCEED 0.152mm (.006") PER SIDE
5. LEAD COPLANARITY (BOTTOM OF LEADS AFTER FORMING) SHALL BE 0.102mm (.004") MAX

REVISION HISTORY

REV	DATE	DESCRIPTION	PAGE NUMBER
A	12/12	Addition of A-grade Performance and Electrical Characteristics	1, 3, 4, 11, 13, 15 (Fig10), 28
		Correction to Typical Application diagram	1
		Addition of A-grade Order Information	2
		Clarification to Absolute Maximum Short Circuit Duration	2
		Edits to Electrical Characteristics conditions and notes	3, 4
		Clarification to nomenclature used in Typical Performance Characteristics	5-8
		Clarification to Description of Pin Functions	8, 9
		Internal Reference Block redrawn for consistency	9, 10, 12, 17, 18, 19, 25, 26
		Edits to Applications Information	10-16, 18, 20-25
		Addition of LT6108 to Related Parts	28

Looking for pricing, stock, or lifecycle information?

Click below to explore more details on WIN SOURCE:

 [View LT6109AHMS-1#PBF on WIN SOURCE](#)

 [Analog Devices Inc. Information](#)

Optimize Your Supply Chain with WIN SOURCE Solutions

-  Global Sourcing Solution
-  Obsolete Management
-  Cost Control Management
-  Shortage Management
-  Alternative Solution
-  Excess Inventory Management