



**THE DATASHEET OF
DS4266D+**



DDR Clock Oscillator

General Description

The DS4266 surface-mount ceramic crystal oscillator is part of Maxim's DS4-XO crystal oscillator product family. The DS4266 is a 266MHz crystal oscillator designed to support high-performance DDR memory applications that require a stable, low-jitter, and tight duty-cycle clock source. The device provides an overall accuracy and stability better than ± 50 ppm, including aging. Jitter performance is better than $0.7\text{ps}_{\text{RMS}}$ typically over a 12kHz to 20MHz bandwidth, and duty-cycle performance is better than 48%/52%.

The DS4266 has an output frequency of 266MHz, and it supports LVDS and LVPECL output types. The DS4266 is constructed using a fundamental crystal in conjunction with high-performance silicon germanium PLL technology, enabling very low phase noise and phase jitter performance. The device operates from a $3.3\text{V} \pm 5\%$ power supply and consumes a maximum current of 100mA.

The DS4266 is packaged in a miniature 5mm x 3.2mm x 1.49mm, 10-lead LCCC ceramic package, making it suitable for applications where board space is critical.

Applications

DDR Memory Clock Source

Features

- ◆ $< 0.7\text{ps}_{\text{RMS}}$ (typ) from 12kHz to 20MHz Jitter
- ◆ LVDS or LVPECL Output Types
- ◆ 3.3V Operating Voltage
- ◆ 5.0mm x 3.2mm x 1.49mm, 10-Pin LCCC Ceramic Package
- ◆ -40°C to $+85^{\circ}\text{C}$ Operating Temperature Range
- ◆ Lead-Free/RoHS Compliant

Ordering Information

PART	TEMP RANGE	PIN-PACKAGE
DS4266D+	-40°C to $+85^{\circ}\text{C}$	10 LCCC
DS4266P+	-40°C to $+85^{\circ}\text{C}$	10 LCCC

+ Denotes a lead(Pb)-free/RoHS-compliant package. The lead finish is JESD97 category e4 (Au over Ni) and is compatible with both lead-based and lead-free soldering processes.

Pin Configuration and Selector Guide appear at end of data sheet.

Typical Operating Circuits

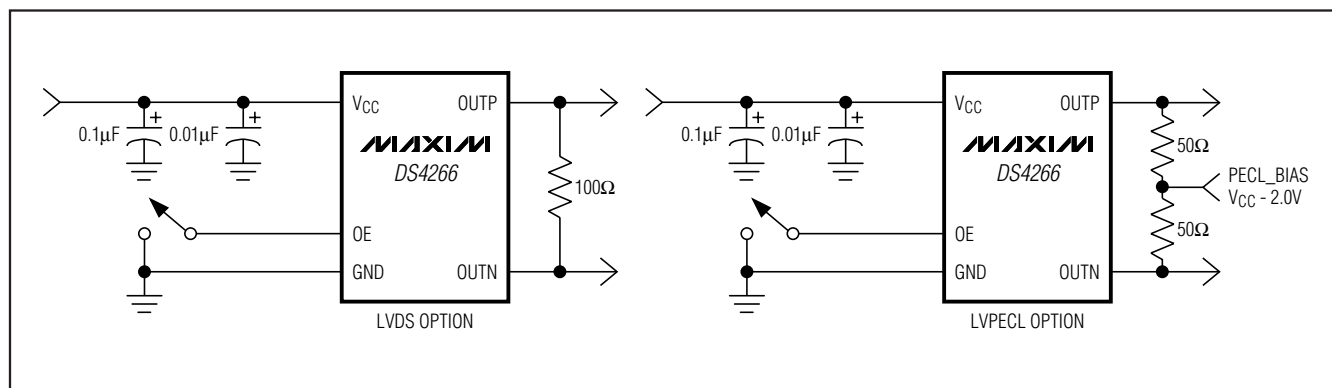

DDR Clock Oscillator

ABSOLUTE MAXIMUM RATINGS

Power-Supply Voltage (V_{CC})-0.3V, +4V
 Operating Temperature Range-40°C to +85°C
 Junction Temperature+150°C

Storage Temperature Range-55°C to +85°C
 Soldering Temperature Profile
 (3 passes max of reflow)Refer to the IPC/JEDEC
 J-STD-020 Specification.

Stresses beyond those listed under "Absolute Maximum Ratings" may cause permanent damage to the device. These are stress ratings only, and functional operation of the device at these or any other conditions beyond those indicated in the operational sections of the specifications is not implied. Exposure to absolute maximum rating conditions for extended periods may affect device reliability.

ELECTRICAL CHARACTERISTICS

($V_{CC} = 3.135V$ to $3.465V$, $T_A = -40^\circ C$ to $+85^\circ C$, unless otherwise noted.)

PARAMETER	SYMBOL	CONDITIONS	MIN	TYP	MAX	UNITS
Operating Voltage Range	V_{CC}	(Note 1)	3.135	3.3	3.465	V
Operating Current	I_{CC_D}	LVDS, output loaded or unloaded		52	75	mA
	I_{CC_PU}	LVPECL, output unloaded		49	70	
	I_{CC_PI}	LVPECL, output load 50Ω at $V_{CC} - 2.0V$		74	100	
Output Frequency	f_{OUT}			f_{NOM}		MHz
Oscillator Startup Time	$t_{STARTUP}$	(Note 2)			50	ms
Frequency Stability	Δf_{TOTAL}	Over temperature range, aging, load, supply, and initial tolerance (Note 3)	-50	f_{NOM}	+50	ppm
Frequency Stability Over Temperature with Initial Tolerance	Δf_{TEMP}	$V_{CC} = 3.3V$	-35		+35	ppm
Initial Tolerance	$\Delta f_{INITIAL}$	$V_{CC} = 3.3V$, $T_A = +25^\circ C$		± 20		ppm
Frequency Change Due to ΔV_{CC}	Δf_{VCC}	$V_{CC} = 3.3V \pm 5\%$	-3		+3	ppm/V
Frequency Change Due to Load Variation	Δf_{LOAD}	$\pm 10\%$ variation in termination resistance		± 1		ppm
Aging (15 Years)	Δf_{AGING}		-7		+7	ppm
Jitter	J_{RMS}	Integrated phase RMS; 12kHz to 5MHz, $V_{CC} = 3.3V$, $T_A = +25^\circ C$		0.7		ps
		Integrated phase RMS; 12kHz to 20MHz, $V_{CC} = 3.3V$, $T_A = +25^\circ C$		0.7		
		Integrated phase RMS; 12kHz to 80MHz, $V_{CC} = 3.3V$, $T_A = +25^\circ C$		1.0		
Input-Voltage High (OE)	V_{IH}	(Note 1)	$0.7 \times V_{CC}$		V_{CC}	V
Input-Voltage Low (OE)	V_{IL}	(Note 1)	0		$0.3 \times V_{CC}$	V
Input Leakage (OE)	I_{LEAK}	$GND \leq OE \leq V_{CC}$	-50		+5.0	μA

DDR Clock Oscillator

DS4266

ELECTRICAL CHARACTERISTICS (continued)

($V_{CC} = 3.135V$ to $3.465V$, $T_A = -40^{\circ}C$ to $+85^{\circ}C$, unless otherwise noted.)

PARAMETER	SYMBOL	CONDITIONS	MIN	TYP	MAX	UNITS
LVDS						
Output High Voltage	$V_{OHLVDSO}$	100 Ω differential load (Note 1)			1.475	V
Output Low Voltage	$V_{OLLVDSO}$	100 Ω differential load (Note 1)	0.925			V
Differential Output Voltage	$ V_{ODLVDSO} $	100 Ω differential load	250		425	mV
Output Common-Mode Voltage Variation	$V_{LVDSOCOM}$	100 Ω differential load			150	mV
Change in Differential Magnitude or Complementary Inputs	$\Delta V_{ODLVDSO} $	100 Ω differential load			25	mV
Offset Output Voltage	$V_{OFFLVDSO}$	100 Ω differential load (Note 1)	1.125		1.275	V
Differential Output Impedance	R_{OLVDSO}		80		140	Ω
Output Current	$I_{LVSSLVDSO}$	OUTN or OUTP shorted to ground and measure the current in the shorting path			40	mA
	I_{LLVDSO}	OUTN or OUTP shorted together		6.5		
Output Rise Time (Differential)	t_{RLVDSO}	20% to 80%		175		ps
Output Fall Time (Differential)	t_{FLVDSO}	80% to 20%		175		ps
Duty Cycle	D_{CYCLE_LVDS}		48		52	%
Propagation Delay from OE Going Low to Logical 1 at OUTP	t_{PA1}				200	ns
Propagation Delay from OE Going High to Output Active	t_{P1A}				200	ns
LVPECL						
Output High Voltage	V_{OH}	Output connected to 50 Ω at PECL_BIAS at $V_{CC} - 2.0V$	$V_{CC} - 1.085$		$V_{CC} - 0.88$	V
Output Low Voltage	V_{OL}	Output connected to 50 Ω at PECL_BIAS at $V_{CC} - 2.0V$	$V_{CC} - 1.825$		$V_{CC} - 1.62$	V
Differential Voltage	V_{DIFF_PECL}	Output connected to 50 Ω at PECL_BIAS at $V_{CC} - 2.0V$	0.595	0.710		V
Rise Time	t_{R-PECL}			200		ps
Fall Time	t_{F-PECL}			200		ps
Duty Cycle	D_{CYCLE_PECL}		48		52	%
Propagation Delay from OE Going Low to Output High Impedance	t_{PAZ}				200	ns
Propagation Delay from OE Going High to Output Active	t_{PZA}				200	ns

Note 1: All voltages referenced to ground.

Note 2: AC parameters are guaranteed by design and not production tested.

Note 3: Frequency stability is calculated as: $\Delta f_{TOTAL} = \Delta f_{TEMP} + \Delta f_{VCC} \times (3.3 \times 5\%) + \Delta f_{LOAD} + \Delta f_{AGING}$.

DDR Clock Oscillator

Single-Sideband Phase Noise at $f_O = f_{NOM}$

$f_M =$	SINGLE-SIDEBAND PHASE NOISE AT $f_O = f_{NOM}$ (dBc/Hz)
	266MHz
10Hz	-65
100Hz	-95
1kHz	-113
10kHz	-113
100kHz	-118
1MHz	-137
10MHz	-149
20MHz	-153

Typical Operating Characteristics

($V_{CC} = +3.3V$, $T_A = +25^\circ C$, unless otherwise noted.)

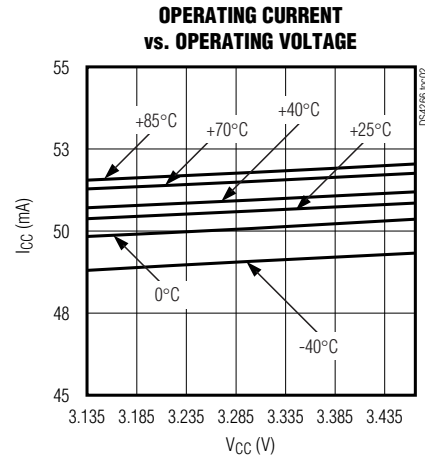
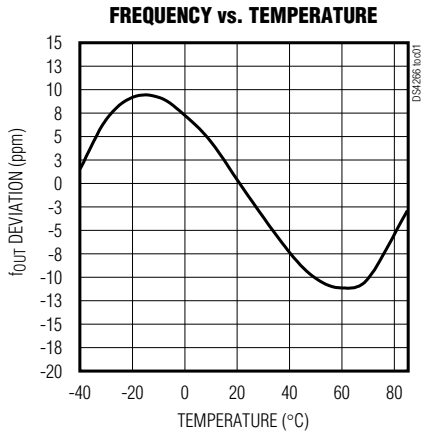

Pin Description

PIN	NAME	FUNCTION
1	OE	Active-High Output Enable. Has an internal pullup 100k Ω resistor.
2, 7-10	N.C.	No Connection. Must be floated.
3	GND	Ground
4	OUTP	Positive Output for LVPECL or LVDS
5	OUTN	Negative Output for LVPECL or LVDS
6	V_{CC}	Supply Voltage
—	EP	Exposed Paddle. Do not connect this pad or place exposed metal under the pad.

DDR Clock Oscillator

DS4266

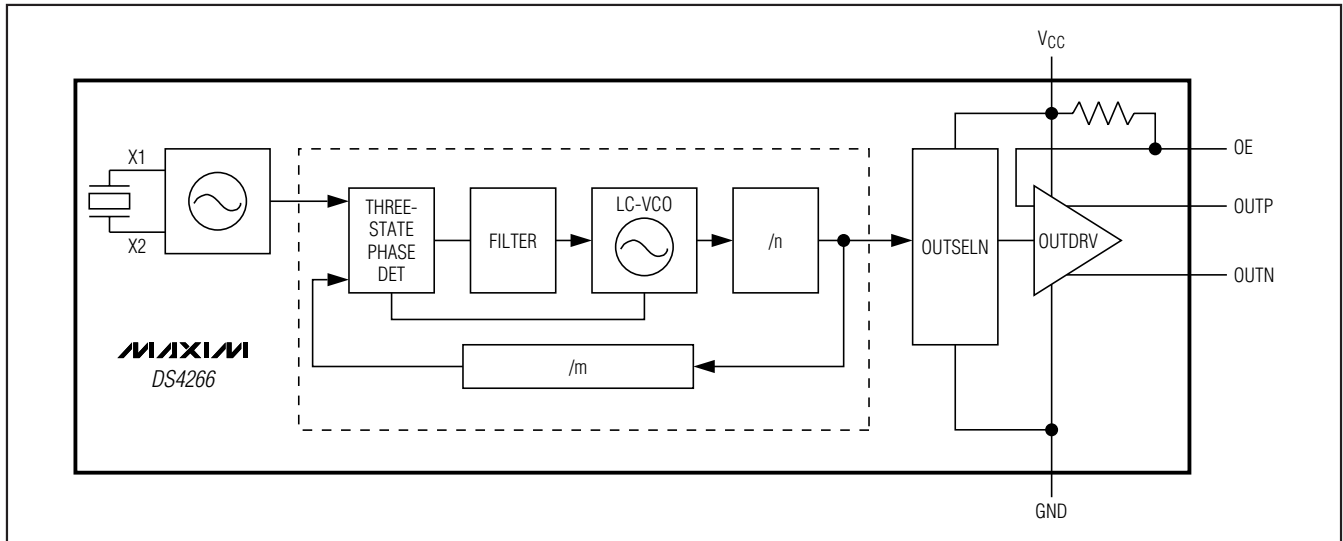

Figure 1. Functional Diagram

Detailed Description

The DS4266 consists of a fundamental-mode crystal and synthesizer IC packaged in a 5mm x 3.2mm x 1.49mm, 10-pin LCCC ceramic package. The device produces a frequency output of 266.00MHz. Two differential output types are available: LVDS and LVPECL. The device output can be enabled or disabled through the OE signal input. When the OE signal is low, LVPECL

outputs go to the PECL_BAS level of $V_{CC} - 2.9V$, while the LVDS outputs are a logical 1. See Figures 2 and 3 for LVDS and LVPECL output timing diagrams.

Additional Information

For more available frequencies in the DS4-XO family, refer to the DS4125 data sheet at www.maxim-ic.com/DS4125.

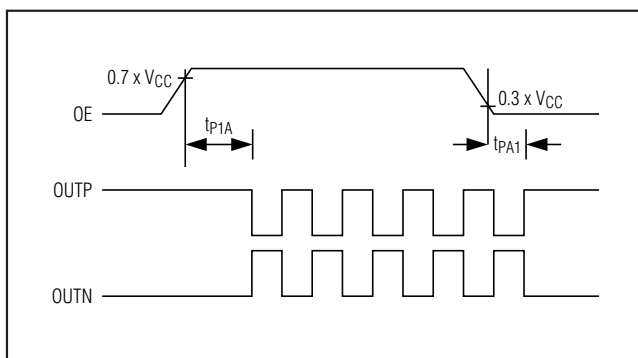

Figure 2. LVDS Output Timing Diagram When OE Is Enabled and Disabled

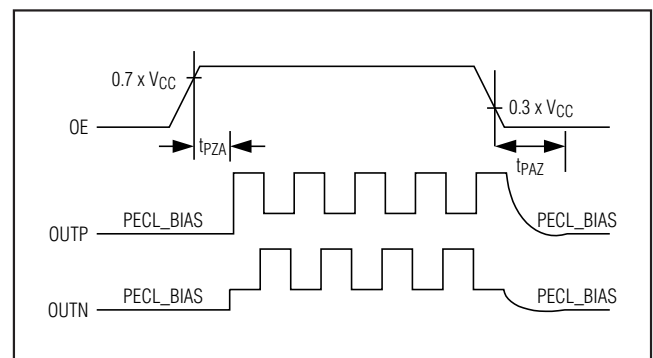

Figure 3. LVPECL Output Timing Diagram When OE Is Enabled and Disabled

DDR Clock Oscillator

Selector Guide

PART	FREQUENCY (NOM) (MHz)	FREQUENCY STABILITY (ppm)	OUTPUT TYPE	TOP MARK
DS4266D+	266	±50	LVDS	66D
DS4266P+	266	±50	LVPECL	66P

+Denotes a lead(Pb)-free/RoHS-compliant package. The lead finish is JESD97 category e4 (Au over Ni) and is compatible with both lead-based and lead-free soldering processes.

Pin Configuration

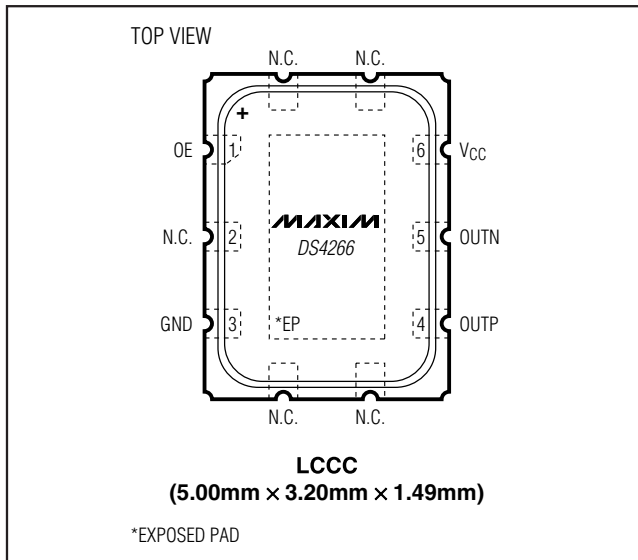

Chip Information

SUBSTRATE CONNECTED TO GROUND
PROCESS: BiPOLAR SiGe

Thermal Information

THETA-JA (°C/W)
90

Package Information

For the latest package outline information and land patterns, go to www.maxim-ic.com/packages.



PACKAGE TYPE	PACKAGE CODE	DOCUMENT NO.
10 LCCC	L1053+H2	21-0389

Maxim cannot assume responsibility for use of any circuitry other than circuitry entirely embodied in a Maxim product. No circuit patent licenses are implied. Maxim reserves the right to change the circuitry and specifications without notice at any time.

6 **Maxim Integrated Products, 120 San Gabriel Drive, Sunnyvale, CA 94086 408-737-7600**

Looking for pricing, stock, or lifecycle information?

Click below to explore more details on WIN SOURCE:

-  [View DS4266D+ on WIN SOURCE](#)
-  [Maxim Integrated Information](#)

Optimize Your Supply Chain with WIN SOURCE Solutions

-  Global Sourcing Solution
-  Obsolete Management
-  Cost Control Management
-  Shortage Management
-  Alternative Solution
-  Excess Inventory Management