



# THE DATASHEET OF NTE6008





ELECTRONICS, INC.  
 44 FARRAND STREET  
 BLOOMFIELD, NJ 07003  
 (973) 748-5089  
<http://www.nteinc.com>

## NTE6006 thru NTE6011 Fast Recovery Rectifier, 200ns 40 Amp, DO5

**Description:**

The NTE6006 through NTE6011 are fast recovery silicon rectifiers in a DO5 type package designed for special applications such as DC power supplies, inverters, converters, ultrasonic systems, chop-pers, low RF interference, sonar power supplies, and free wheeling diodes. A complete line of fast recovery rectifiers, these devices have a typical recovery time of 150ns providing high efficiency at frequencies to 250kHz.

**Absolute Maximum Ratings:** (Note 1)

Peak Repetitive Reverse Voltage,  $V_{RRM}$

Working Peak Reverse Voltage,  $V_{RWM}$

DC Blocking Voltage,  $V_R$

NTE6006, NTE6007*	200V
NTE6008, NTE6009*	400V
NTE6010, NTE6011*	600V

Non-Repetitive Peak Reverse Voltage,  $V_{RSM}$

NTE6006, NTE6007*	250V
NTE6008, NTE6009*	450V
NTE6010, NTE6011*	650V

RMS Reverse Voltage,  $V_{R(RMS)}$

NTE6006, NTE6007*	140V
NTE6008, NTE6009*	280V
NTE6010, NTE6011*	420V

Average Rectified Forward Current (Single phase, resistive load,  $T_C = +100^\circ C$ ),  $I_O$  . . . . . 40A

Non-Repetitive Peak Surge Current (Surge applied at rated load conditions),  $I_{FSM}$  . . . . . 350A

Operating Junction Temperature Range,  $T_J$  . . . . .  $-65^\circ$  to  $+160^\circ C$

Storage Temperature Range,  $T_{stg}$  . . . . .  $-65^\circ$  to  $+175^\circ C$

Thermal Resistance, Junction-to-Case,  $R_{thJC}$  . . . . .  $0.85^\circ C/W$

Note 1. \* Indicates Anode-to-Case polarity, Cathode-to-Case is standard.

**Electrical Characteristics:**

Parameter	Symbol	Test Conditions	Min	Typ	Max	Unit
Instantaneous Forward Voltage	$v_F$	$i_F = 125A, T_J = +150^\circ C$	-	1.3	1.6	V
Forward Voltage	$V_F$	$I_F = 40A, T_C = +25^\circ C$	-	1.0	1.4	V
Reverse Current (Rated DC Voltage)	$I_R$	$T_C = +25^\circ C$	-	25	50	$\mu A$
		$T_C = +100^\circ C$	-	1.0	2.0	mA

**Reverse Recovery Characteristics:**

Parameter	Symbol	Test Conditions	Min	Typ	Max	Unit
Reverse Recovery Time	$t_{rr}$	$I_F = 1A$ to $V_R = 30V$	-	150	200	ns
		$I_{FM} = 36A, di/dt = 25A/\mu s$	-	200	400	ns
Reverse Recovery Current	$I_{RM(REC)}$	$I_F = 1A$ to $V_R = 30V$	-	2.0	3.0	A

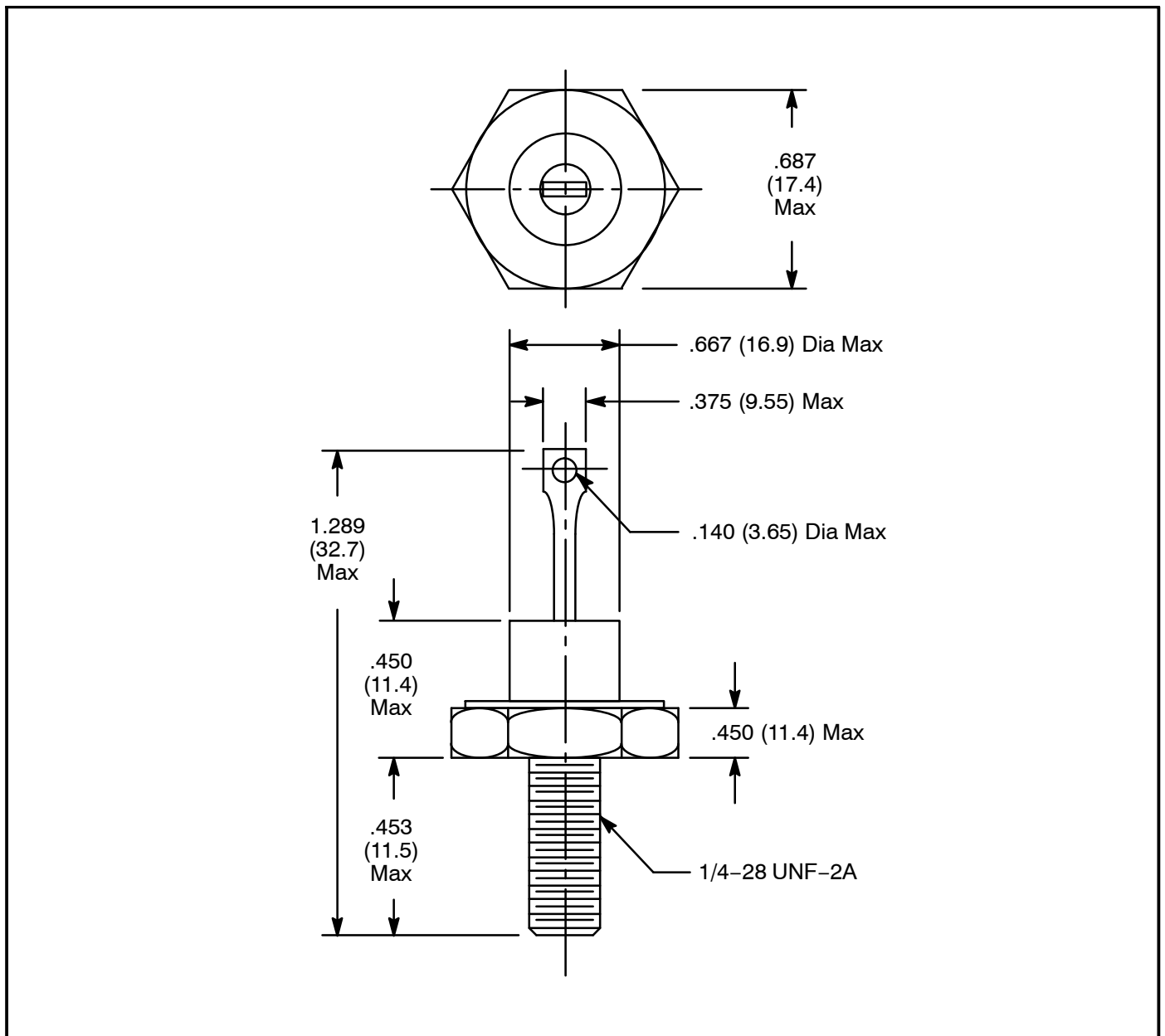

## Looking for pricing, stock, or lifecycle information?

Click below to explore more details on WIN SOURCE:

 [View NTE6008 on WIN SOURCE](#)

 [NTE Information](#)

## Optimize Your Supply Chain with WIN SOURCE Solutions

-  Global Sourcing Solution
-  Obsolete Management
-  Cost Control Management
-  Shortage Management
-  Alternative Solution
-  Excess Inventory Management