



# THE DATASHEET OF NBSG72AMNEVB



# NBSG72A

## 2.5V/3.3V SiGe Differential 2 X 2 Crosspoint Switch with Output Level Select

The NBSG72A is a high-bandwidth fully differential 2 X 2 crosspoint switch with Output Level Select (OLS) capabilities. This is a part of the GigaComm™ family of high performance Silicon Germanium products. The device is housed in a low profile 3 X 3 mm 16-pin QFN package.

Differential inputs incorporate internal 50 Ω termination resistors and accept NECL (Negative ECL), PECL (Positive ECL), LVCMOS/LVTTL, CML, or LVDS. The OLS input is used to program the peak-to-peak output amplitude between 0 mV and 800 mV in five discrete steps. The SELECT inputs are single-ended and can be driven with either LVECL or LVCMOS/LVTTL input levels.

- Maximum Input Clock Frequency > 7 GHz Typical
- Maximum Input Data Rate > 7 Gb/s Typical
- 200 ps Typical Propagation Delay (OLS = FLOAT)
- 55/45 ps Typical Rise/Fall Times (OLS = FLOAT)
- Selectable Swing PECL Output with Operating Range:  
 $V_{CC} = 2.375 \text{ V}$  to  $3.465 \text{ V}$  with  $V_{EE} = 0 \text{ V}$
- Selectable Swing NECL Output with NECL Inputs with  
Operating Range:  $V_{CC} = 0 \text{ V}$  with  $V_{EE} = -2.375 \text{ V}$  to  $-3.465 \text{ V}$
- Selectable Output Levels (0 mV, 200 mV, 400 mV, 600 mV or  
800 mV Peak-to-Peak Output)
- 50 Ω Internal Input Termination Resistors
- Single-Ended LVECL or LVCMOS/LVTTL Select Inputs  
(SELA, SELB)
- Pb-Free Package is Available



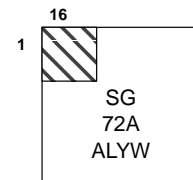
ON Semiconductor®

<http://onsemi.com>

### MARKING DIAGRAM\*



QFN-16  
MN SUFFIX  
CASE 485G



A = Assembly Location  
L = Wafer Lot  
Y = Year  
W = Work Week

\*For additional marking information, refer to  
Application Note AND8002/D.

### ORDERING INFORMATION

See detailed ordering and shipping information in the package  
dimensions section on page 13 of this data sheet.

# NBSG72A

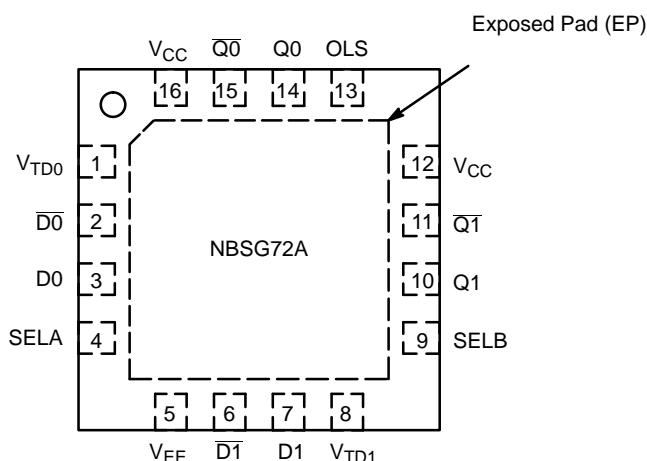


Figure 1. QFN-16 Pinout (Top View)

Table 1. PIN DESCRIPTION

Pin No.	Name	I/O	Description
1	VTD0	-	Common Internal 50 $\Omega$ Termination Pin for D0 and $\overline{D0}$ Input. See Table 4. (Note 1)
2	$\overline{D0}$	LVDS, CML, ECL, LVTTTL, LVCMOS Input	Inverted Differential Input 0.
3	D0	LVDS, CML, ECL, LVTTTL, LVCMOS Input	Noninverted Differential Input 0.
4	SELA	LVECL, LVCMOS Input	Select Logic Input A. Internal 75 k $\Omega$ Pulldown to $V_{EE}$ .
5	$V_{EE}$	-	Negative Supply. All $V_{EE}$ Pins must be Externally Connected to Power Supply to Guarantee Proper Operation.
6	$\overline{D1}$	LVDS, CML, ECL, LVTTTL, LVCMOS Input	Inverted Differential Input 1.
7	D1	LVDS, CML, ECL, LVTTTL, LVCMOS Input	Noninverted Differential Input 1.
8	VTD1	-	Common Internal 50 $\Omega$ Termination Pin for D1 and $\overline{D1}$ Input. See Table 4. (Note 1)
9	SELB	LVECL, LVCMOS Input	Select Logic Input B. Internal 75 k $\Omega$ Pulldown to $V_{EE}$ .
10	Q1	RSECL Output	Noninverted Differential Output.
11	$\overline{Q1}$	RSECL Output	Inverted Differential Output.
12	$V_{CC}$	-	Positive Supply. All $V_{CC}$ Pins must be Externally Connected to Power Supply to Guarantee Proper Operation.
13	OLS (Note 2)	Input	Input Pin for Output Level Select (OLS) See Table 3.
14	Q0	RSECL Output	Noninverted Differential Output Typically Terminated with 50 $\Omega$ Resistor to $V_{TT} = V_{CC} - 2.0$ V.
15	$\overline{Q0}$	RSECL Output	Inverted Differential Output Typically Terminated with 50 $\Omega$ Resistor to $V_{TT} = V_{CC} - 2.0$ V.
16	$V_{CC}$	-	Positive Supply. All $V_{CC}$ Pins must be Externally Connected to Power Supply to Guarantee Proper Operation.
-	EP	-	Exposed Pad. The thermally exposed pad on package bottom (see case drawing) must be attached to a heat-sinking conduit.

1. In the differential configuration when the input termination pins (VTD0, VTD1) are connected to a common termination voltage, and if no signal is applied then the device will be susceptible to self-oscillation.
2. When an output level of 400 mV is desired and  $V_{CC} - V_{EE} > 3.0$  V, 2 k $\Omega$  resistor should be connected from OLS pin to  $V_{EE}$ .

# NBSG72A

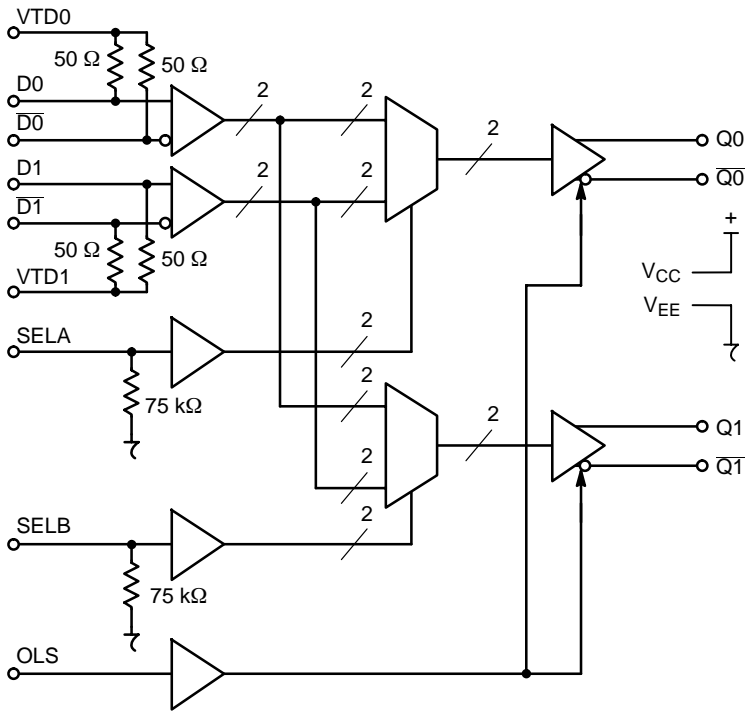


Figure 2. Logic/Block Diagram

Table 2. TRUTH TABLE

SELA	SELB	Q0	Q1
LOW	LOW	D0	D0
HIGH	LOW	D1	D0
LOW	HIGH	D0	D1
HIGH	HIGH	D1	D1

Table 3. OUTPUT LEVEL SELECT (OLS)

OLS	Output Amplitude ( $V_{OUTPP}$ )	OLS Sensitivity
$V_{CC}$	800 mV	OLS - 75 mV
$V_{CC} - 0.4$ V	200 mV	OLS $\pm$ 150 mV
$V_{CC} - 0.8$ V	600 mV	OLS $\pm$ 100 mV
$V_{CC} - 1.2$ V	0	OLS $\pm$ 75 mV
$V_{EE}$ (Note 3)	400 mV	OLS $\pm$ 100 mV
FLOAT	600 mV	N/A

3. When an output level of 400 mV is desired and  $V_{CC} - V_{EE} > 3.0$  V, a 2 k $\Omega$  resistor should be connected from OLS to  $V_{EE}$ .

Table 4. INTERFACING OPTIONS

Interfacing Options	Connections
CML	Connect VTD0 and VTD1 to $V_{CC}$
LVDS	VTD0 and VTD1 Should Be Left Floating.
AC-COUPLED	Bias VTD0 and VTD1 Inputs within Common Mode Range (VIHCMR)
RSECL, PECL, NECL	Standard ECL Termination Techniques
LVC MOS / LVTTTL	The external voltage should be applied to the unused complementary differential input. Nominal voltage is 1.5 V for LVTTTL and $V_{CC}/2$ for LVC MOS Inputs.

# NBSG72A

**Table 5. ATTRIBUTES**

Characteristics	Value
Internal Input Pulldown Resistor (SELA, SELB)	75 kΩ
ESD Protection	Human Body Model Machine Model Charged Device Model
	> 2 kV > 50 V > 1 kV
Moisture Sensitivity (Note 1)	Level 1
Flammability Rating	Oxygen Index: 28 to 34
	UL 94 V-0 @ 0.125 in
Transistor Count	436
Meets or exceeds JEDEC Spec EIA/JESD78 IC Latchup Test	

1. For additional information, see Application Note AND8003/D.

**Table 6. MAXIMUM RATINGS**

Symbol	Parameter	Condition 1	Condition 2	Rating	Units
$V_{CC}$	Positive Power Supply	$V_{EE} = 0\text{ V}$		3.6	V
$V_{EE}$	Negative Power Supply	$V_{CC} = 0\text{ V}$		-3.6	V
$V_I$	Positive Input Negative Input	$V_{EE} = 0\text{ V}$ $V_{CC} = 0\text{ V}$	$V_I \leq V_{CC}$ $V_I \geq V_{EE}$	3.6 -3.6	V V
$V_{INPP}$	Differential Input Voltage $ D_X - \overline{D_X} $	$V_{EE} - V_{CC} \geq 2.8\text{ V}$ $V_{EE} - V_{CC} < 2.8\text{ V}$		2.8 $ V_{CC} - V_{EE} $	V
$I_{out}$	Output Current	Continuous Surge		25 50	mA mA
$I_{IN}$	Input Current Through $R_T$ (50 Ω Resistor)	Static Surge		45 80	mA mA
$T_A$	Operating Temperature Range			-40 to +85	°C
$T_{stg}$	Storage Temperature Range			-65 to +150	°C
$\theta_{JA}$	Thermal Resistance (Junction-to-Ambient) (Note 2)	0 lfpm 500 lfpm	QFN-16 QFN-16	42 35	°C/W °C/W
$\theta_{JC}$	Thermal Resistance (Junction-to-Case)	(Note 2)	QFN-16	4	°C/W
$T_{sol}$	Wave Solder	< 15 sec		225	°C

Maximum ratings are those values beyond which device damage can occur. Maximum ratings applied to the device are individual stress limit values (not normal operating conditions) and are not valid simultaneously. If these limits are exceeded, device functional operation is not implied, damage may occur and reliability may be affected.

2. JEDEC standard multilayer board – 1S2P (1 signal, 2 power).

# NBSG72A

**Table 7. DC CHARACTERISTICS, INPUT WITH PECL OUTPUT**  $V_{CC} = 2.5\text{ V}$ ;  $V_{EE} = 0\text{ V}$  (Note 3)

Symbol	Characteristic	-40°C			25°C			85°C			Unit
		Min	Typ	Max	Min	Typ	Max	Min	Typ	Max	
$I_{EE}$	Negative Power Supply Current	40	55	65	40	55	65	40	55	65	mA
$V_{OH}$	Output HIGH Voltage (Note 4)	1460	1510	1560	1490	1540	1590	1515	1565	1615	mV
$V_{OL}$	Output LOW Voltage (Note 4)										mV
	(OLS = $V_{CC}$ )	555	705	855	595	745	895	625	775	925	
	(OLS = $V_{CC} - 0.4\text{ V}$ )	1235	1295	1355	1270	1330	1390	1295	1355	1415	
	(OLS = $V_{CC} - 0.8\text{ V}$ , OLS = FLOAT)	775	895	1015	810	930	1050	840	960	1080	
	(OLS = $V_{CC} - 1.2\text{ V}$ )	1455	1505	1555	1490	1540	1590	1510	1560	1610	
	(OLS = $V_{EE}$ )	1005	1095	1185	1040	1130	1220	1065	1155	1245	
$V_{OUTPP}$	Output Voltage Amplitude										mV
	(OLS = $V_{CC}$ )	700	800		680	795		680	790		
	(OLS = $V_{CC} - 0.4\text{ V}$ )	125	215		120	210		120	210		
	(OLS = $V_{CC} - 0.8\text{ V}$ , OLS = FLOAT)	525	615		520	610		515	605		
	(OLS = $V_{CC} - 1.2\text{ V}$ )	0	5		0	0		0	5		
	(OLS = $V_{EE}$ )	325	415		320	410		320	410		
$V_{IH}$	Input HIGH Voltage (Single-Ended) (Note 6) D0, $\overline{D0}$ , D1, $\overline{D1}$	$V_{EE} + 1275$	$V_{CC} - 1000^*$	$V_{CC}$	$V_{EE} + 1275$	$V_{CC} - 1000^*$	$V_{CC}$	$V_{EE} + 1275$	$V_{CC} - 1000^*$	$V_{CC}$	mV
$V_{IL}$	Input LOW Voltage (Single-Ended) (Note 7) D0, $\overline{D0}$ , D1, $\overline{D1}$	$V_{EE}$	$V_{CC} - 1400^*$	$V_{IH} - 150$	$V_{EE}$	$V_{CC} - 1400^*$	$V_{IH} - 150$	$V_{EE}$	$V_{CC} - 1400^*$	$V_{IH} - 150$	mV
$V_{IHCMR}$	Input HIGH Voltage Common Mode Range (Differential Configuration) (Note 5)	1.2		2.5	1.2		2.5	1.2		2.5	V
$R_{TIN}$	Internal Input Termination Resistor	45	50	55	45	50	55	45	50	55	$\Omega$
$I_{IH}$	Input HIGH Current (@ $V_{IH}$ )		35	100		35	100		35	100	$\mu\text{A}$
$I_{IL}$	Input LOW Current (@ $V_{IL}$ )		20	100		20	100		20	100	$\mu\text{A}$

NOTE: Device will meet the specifications after thermal equilibrium has been established when mounted in a test socket or printed circuit board with maintained transverse airflow greater than 500 lpm. Electrical parameters are guaranteed only over the declared operating temperature range. Functional operation of the device exceeding these conditions is not implied. Device specification limit values are applied individually under normal operating conditions and not valid simultaneously.

\*Typicals used for testing purposes.

3. Input and output parameters vary 1:1 with  $V_{CC}$ .  $V_{EE}$  can vary +0.125 V to -0.965 V.

4. All loading with 50  $\Omega$  to  $V_{CC} - 2.0\text{ V}$ .

5.  $V_{IHCMR}$  min varies 1:1 with  $V_{EE}$ ,  $V_{IHCMR}$  max varies 1:1 with  $V_{CC}$ . The  $V_{IHCMR}$  range is referenced to the most positive side of the differential input signal.

6.  $V_{IH}$  cannot exceed  $V_{CC}$ .

7.  $V_{IL}$  always  $\geq V_{EE}$ .

# NBSG72A

**Table 8. DC CHARACTERISTICS, INPUT WITH PECL OUTPUT**  $V_{CC} = 3.3\text{ V}$ ;  $V_{EE} = 0\text{ V}$  (Note 8)

Symbol	Characteristic	-40°C			25°C			85°C			Unit
		Min	Typ	Max	Min	Typ	Max	Min	Typ	Max	
$I_{EE}$	Negative Power Supply Current	40	55	65	40	55	65	40	55	65	mA
$V_{OH}$	Output HIGH Voltage (Note 9)	2260	2310	2360	2290	2340	2390	2315	2365	2415	mV
$V_{OL}$	Output LOW Voltage (Note 9)										mV
	(OLS = $V_{CC}$ )	1320	1470	1620	1360	1510	1660	1390	1540	1690	
	(OLS = $V_{CC} - 0.4\text{ V}$ )	2030	2090	2150	2065	2125	2185	2090	2150	2210	
	(OLS = $V_{CC} - 0.8\text{ V}$ , OLS = FLOAT)	1550	1670	1790	1585	1705	1825	1615	1735	1855	
	(OLS = $V_{CC} - 1.2\text{ V}$ )	2260	2310	2360	2290	2340	2390	2315	2365	2415	
	** (OLS = $V_{EE}$ )	1785	1875	1965	1820	1910	2000	1850	1940	2030	
$V_{OUTPP}$	Output Amplitude Voltage										mV
	(OLS = $V_{CC}$ )	715	815		705	805		690	800		
	(OLS = $V_{CC} - 0.4\text{ V}$ )	130	220		125	215		125	215		
	(OLS = $V_{CC} - 0.8\text{ V}$ , OLS = FLOAT)	550	640		545	635		540	630		
	(OLS = $V_{CC} - 1.2\text{ V}$ )	0	0		0	0		0	0		
	** (OLS = $V_{EE}$ )	345	435		340	430		335	425		
$V_{IH}$	Input HIGH Voltage (Single-Ended) (Note 11) D0, $\overline{D0}$ , D1, $\overline{D1}$	$V_{EE} + 1275$	$V_{CC} - 1000^*$	$V_{CC}$	$V_{EE} + 1275$	$V_{CC} - 1000^*$	$V_{CC}$	$V_{EE} + 1275$	$V_{CC} - 1000^*$	$V_{CC}$	mV
$V_{IL}$	Input LOW Voltage (Single-Ended) (Note 12) D0, $\overline{D0}$ , D1, $\overline{D1}$	$V_{IH} - 2600$	$V_{CC} - 1400^*$	$V_{IH} - 150$	$V_{IH} - 2600$	$V_{CC} - 1400^*$	$V_{IH} - 150$	$V_{IH} - 2600$	$V_{CC} - 1400^*$	$V_{IH} - 150$	mV
$V_{IHCMR}$	Input HIGH Voltage Common Mode Range (Differential Configuration) (Note 10)	1.2		3.3	1.2		3.3	1.2		3.3	V
$R_{TIN}$	Internal Input Termination Resistor	45	50	55	45	50	55	45	50	55	$\Omega$
$I_{IH}$	Input HIGH Current (@ $V_{IH}$ )		35	100		35	100		35	100	$\mu\text{A}$
$I_{IL}$	Input LOW Current (@ $V_{IL}$ )		20	100		20	100		20	100	$\mu\text{A}$

NOTE: Device will meet the specifications after thermal equilibrium has been established when mounted in a test socket or printed circuit board with maintained transverse airflow greater than 500 lfm. Electrical parameters are guaranteed only over the declared operating temperature range. Functional operation of the device exceeding these conditions is not implied. Device specification limit values are applied individually under normal operating conditions and not valid simultaneously.

\*Typicals used for testing purposes.

\*\*When an output level of 400 mV is desired and  $V_{CC} - V_{EE} > 3.0\text{ V}$ , a 2 k $\Omega$  resistor should be connected from OLS to  $V_{EE}$ .

8. Input and output parameters vary 1:1 with  $V_{CC}$ .  $V_{EE}$  can vary +0.925 V to -0.165 V.

9. All loading with 50  $\Omega$  to  $V_{CC} - 2.0\text{ V}$ .

10.  $V_{IHCMR}$  min varies 1:1 with  $V_{EE}$ ,  $V_{IHCMR}$  max varies 1:1 with  $V_{CC}$ . The  $V_{IHCMR}$  range is referenced to the most positive side of the differential input signal.

11.  $V_{IH}$  cannot exceed  $V_{CC}$ .

12.  $V_{IL}$  always  $\geq V_{EE}$ .

# NBSG72A

**Table 9. DC CHARACTERISTICS, NECL INPUT WITH NECL OUTPUT**  $V_{CC} = 0\text{ V}$ ;  $V_{EE} = -3.465\text{ V}$  to  $-2.375\text{ V}$  (Note 13)

Symbol	Characteristic	-40°C			25°C			85°C			Unit
		Min	Typ	Max	Min	Typ	Max	Min	Typ	Max	
$I_{EE}$	Negative Power Supply Current	40	55	65	40	55	65	40	55	65	mA
$V_{OH}$	Output HIGH Voltage (Note 14)	-1040	-990	-840	-1010	-960	-910	-985	-935	-885	mV
$V_{OL}$	Output LOW Voltage (Note 14) -3.465 V $\leq V_{EE} \leq$ -3.0 V (OLS = $V_{CC}$ ) (OLS = $V_{CC} - 0.4\text{ V}$ ) (OLS = $V_{CC} - 0.8\text{ V}$ , OLS = FLOAT) (OLS = $V_{CC} - 1.2\text{ V}$ ) **(OLS = $V_{EE}$ ) -3.0 V $< V_{EE} \leq$ -2.375 V (OLS = $V_{CC}$ ) (OLS = $V_{CC} - 0.4\text{ V}$ ) (OLS = $V_{CC} - 0.8\text{ V}$ , OLS = FLOAT) (OLS = $V_{CC} - 1.2\text{ V}$ ) (OLS = $V_{EE}$ )	-1980 -1270 -1750 -1040 -1515 -1945 -1265 -1725 -1045 -1495	-1830 -1210 -1630 -990 -1425 -1795 -1205 -1605 -995 -1405	-1680 -1150 -1510 -940 -1335 -1645 -1145 -1485 -945 -1315	-1940 -1235 -1715 -1010 -1480 -1905 -1230 -1690 -1010 -1460	-1790 -1175 -1595 -960 -1390 -1755 -1170 -1570 -960 -1370	-1640 -1115 -1475 -910 -1300 -1605 -1110 -1450 -910 -1280	-1910 -1210 -1685 -985 -1450 -1875 -1205 -1660 -990 -1435	-1760 -1150 -1565 -935 -1360 -1725 -1145 -1540 -940 -1345	-1610 -1090 -1445 -885 -1270 -1575 -1085 -1420 -890 -1255	mV
$V_{OUTPP}$	Output Voltage Amplitude -3.465 V $\leq V_{EE} \leq$ -3.0 V (OLS = $V_{CC}$ ) (OLS = $V_{CC} - 0.4\text{ V}$ ) (OLS = $V_{CC} - 0.8\text{ V}$ , OLS = FLOAT) (OLS = $V_{CC} - 1.2\text{ V}$ ) **(OLS = $V_{EE}$ ) -3.0 V $< V_{EE} \leq$ -2.375 V (OLS = $V_{CC}$ ) (OLS = $V_{CC} - 0.4\text{ V}$ ) (OLS = $V_{CC} - 0.8\text{ V}$ , OLS = FLOAT) (OLS = $V_{CC} - 1.2\text{ V}$ ) (OLS = $V_{EE}$ )	715 130 550 0 345 700 125 525 0 325	815 220 640 0 435 800 215 615 5 415		705 125 545 0 340 690 120 520 0 320	805 215 635 0 430 795 210 610 0 410		690 125 540 0 335 680 120 515 0 320	800 215 630 0 425 790 210 605 5 410		mV
$V_{IH}$	Input HIGH Voltage (Single-Ended) (Note 16) D0, $\overline{D0}$ , D1, $\overline{D1}$	$V_{EE} + 1275$	$V_{CC} - 1000^*$	$V_{CC}$	$V_{EE} + 1275$	$V_{CC} - 1000^*$	$V_{CC}$	$V_{EE} + 1275$	$V_{CC} - 1000^*$	$V_{CC}$	mV
$V_{IL}$	Input LOW Voltage (Single-Ended) (Note 17) D0, $\overline{D0}$ , D1, $\overline{D1}$	$V_{IH} - 2600$	$V_{CC} - 1400^*$	$V_{IH} - 150$	$V_{IH} - 2600$	$V_{CC} - 1400^*$	$V_{IH} - 150$	$V_{IH} - 2600$	$V_{CC} - 1400^*$	$V_{IH} - 150$	mV
$V_{IHCMR}$	Input HIGH Voltage Common Mode Range (Differential Configuration) (Note 15)	$V_{EE} + 1.2$		0.0	$V_{EE} + 1.2$		0.0	$V_{EE} + 1.2$		0.0	V
$R_{TIN}$	Internal Input Termination Resistor	45	50	55	45	50	55	45	50	55	$\Omega$
$I_{IH}$	Input HIGH Current (@ $V_{IH}$ )		35	100		35	100		35	100	$\mu\text{A}$
$I_{IL}$	Input LOW Current (@ $V_{IL}$ )		20	100		20	100		20	100	$\mu\text{A}$
$I_{OLS}$	OLS Input Current (See Figure 9) (OLS = $V_{CC}$ ) (OLS = $V_{CC} - 0.4\text{ V}$ ) (OLS = $V_{CC} - 0.8\text{ V}$ , OLS = FLOAT) (OLS = $V_{CC} - 1.2\text{ V}$ ) -3.0 V $< V_{EE} \leq$ -2.375 V (OLS = $V_{EE}$ ) -3.465 V $\leq V_{EE} \leq$ -3.0 V *(OLS = $V_{EE}$ )		300 100 5 -300 -1000 -1500	900 300 100 -300 -400 -600		300 100 5 -300 -400 -600	900 300 100 -300 -400 -600		300 100 5 -300 -400 -600	900 300 100 -300 -400 -600	$\mu\text{A}$

NOTE: Device will meet the specifications after thermal equilibrium has been established when mounted in a test socket or printed circuit board with maintained transverse airflow greater than 500 lfm. Electrical parameters are guaranteed only over the declared operating temperature range. Functional operation of the device exceeding these conditions is not implied. Device specification limit values are applied individually under normal operating conditions and not valid simultaneously.

\*Typicals used for testing purposes.

\*\*When an output level of 400 mV is desired and  $V_{CC} - V_{EE} > 3.0\text{ V}$ , a 2 k $\Omega$  resistor should be connected from OLS to  $V_{EE}$ .

13. Input and output parameters vary 1:1 with  $V_{CC}$ .

14. All loading with 50  $\Omega$  to  $V_{CC} - 2.0\text{ V}$ .

15.  $V_{IHCMR}$  min varies 1:1 with  $V_{EE}$ ,  $V_{IHCMR}$  max varies 1:1 with  $V_{CC}$ . The  $V_{IHCMR}$  range is referenced to the most positive side of the differential input signal.

16.  $V_{IH}$  cannot exceed  $V_{CC}$ .

17.  $V_{IL}$  always  $\geq V_{EE}$ .

# NBSG72A

**Table 10. AC CHARACTERISTICS**  $V_{CC} = 0\text{ V}$ ;  $V_{EE} = -3.465\text{ V}$  to  $-2.375\text{ V}$  or  $V_{CC} = 2.375\text{ V}$  to  $3.465\text{ V}$ ;  $V_{EE} = 0\text{ V}$  (Note 18)

Symbol	Characteristic	-40°C			25°C			85°C			Unit	
		Min	Typ	Max	Min	Typ	Max	Min	Typ	Max		
$V_{OUTPP}$	Output Voltage Amplitude $f_{in} < 5\text{ GHz}$ (Note 18)	400	590		450	590		440	590		mV	
	$f_{in} \leq 7\text{ GHz}$	200	250		180	250		130	250			
$t_{PLH}$	Propagation Delay to Output Differential D0, D1 → Q0, Q1 SELA, SELB → Q0, Q1	170 190	205 265	255 350	170 190	205 265	255 350	170 190	210 265	260 350	ps	
$t_{PHL}$	Propagation Delay to Output Differential D0, D1 → Q0, Q1 SELA, SELB → Q0, Q1	170 150	205 215	255 270	170 150	205 215	255 270	170 150	210 215	260 270	ps	
$t_{SKEW}$	Duty Cycle Skew (Note 19) Within-Device Skew Device-to-Device Skew		5.0 5.0 15	25 25 50		5.0 5.0 15	25 25 50		5.0 5.0 15	25 25 50	ps	
$t_{JITTER}$	RMS Random Clock Jitter (Note 20) $f_{in} \leq 7\text{ GHz}$		0.2	1.5		0.2	1.5		0.2	1.5	ps	
	Peak-to-Peak Data Dependent Jitter (Note 21) $f_{in} \leq 7\text{ Gb/s}$		12	18		12	18		12	18		
$V_{INPP}$	Input Voltage Swing/Sensitivity (Differential Configuration) (Note 22)	75		2600	75		2600	75		2600	mV	
$t_r$ $t_f$	Output Rise/Fall Times (Q0, Q1) (20% – 80%) @ 1 GHz		40 30	55 45	70 55	40 30	55 45	70 55	40 30	55 45	70 55	ps

NOTE: Device will meet the specifications after thermal equilibrium has been established when mounted in a test socket or printed circuit board with maintained transverse airflow greater than 500 lpm. Electrical parameters are guaranteed only over the declared operating temperature range. Functional operation of the device exceeding these conditions is not implied. Device specification limit values are applied individually under normal operating conditions and not valid simultaneously.

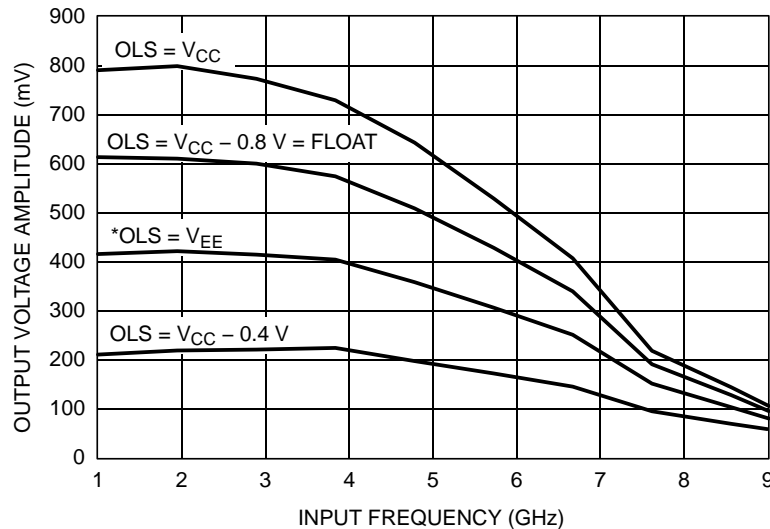
18. Measured using a 75 mV source, 50% duty cycle clock source. All loading with 50  $\Omega$  to  $V_{CC} - 2.0\text{ V}$ . OLS = FLOAT. Input edge rates 40 ps (20% – 80%).

19.  $t_{SKEW} = |t_{PLH} - t_{PHL}|$  for a nominal 50% differential clock input waveform.

20. Additive RMS jitter with 50% Duty Cycle clock signal at 7 GHz.

21. Additive Peak-to-Peak data dependent jitter with NRZ PRBS  $2^{31}-1$  data at 7 Gb/s.

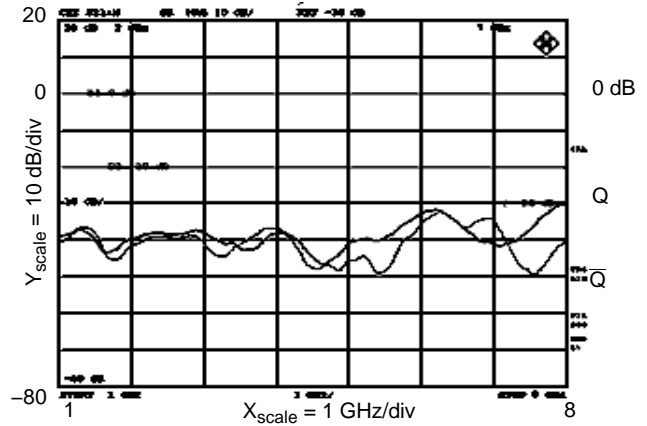
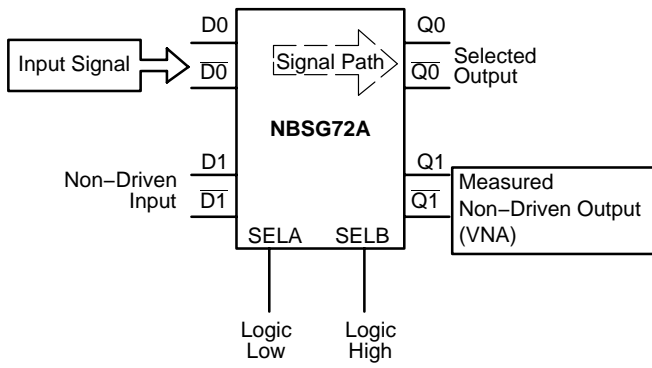
22. Input Voltage Swing is a single-ended measurement operating in differential mode.  $V_{INPP}$  (max) cannot exceed  $V_{CC} - V_{EE}$ .



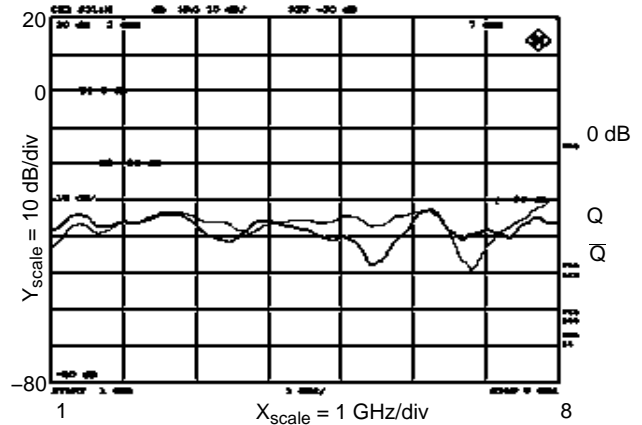
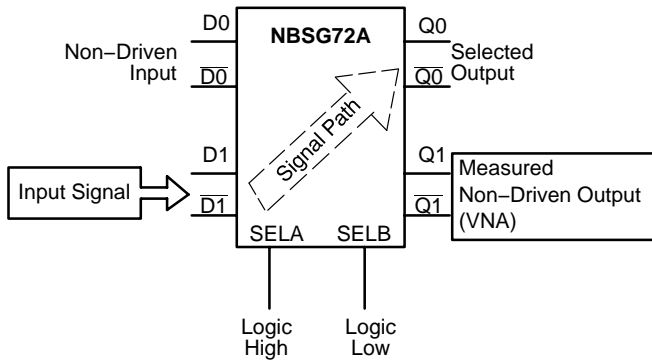
**Figure 3. Output Voltage Amplitude ( $V_{OUTPP}$ ) vs. Input Clock Frequency ( $f_{in}$ ) @ Ambient Temperature (Typical)**

\*When an output level of 400 mV is desired and  $V_{CC} - V_{EE} > 3.0\text{ V}$ , a 2 k $\Omega$  resistor should be connected from OLS to  $V_{EE}$ .

# NBSG72A

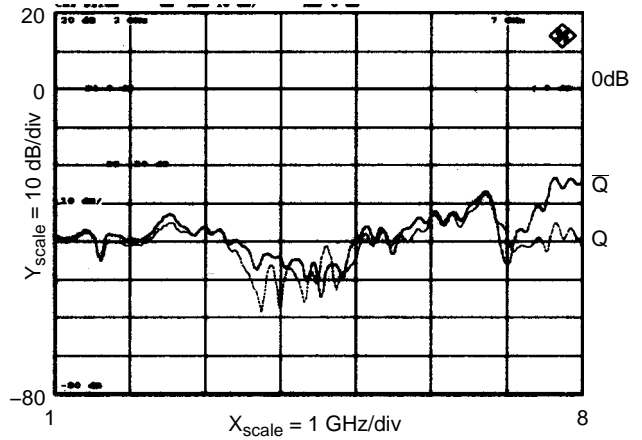
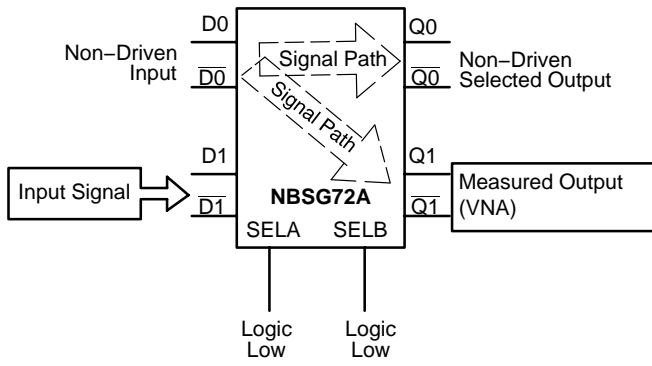


**Figure 4. Channel-to-Channel Crosstalk Isolation at Ambient Temperature (D0 to Q0 Signal Path Selected; SelA = Low, SelB = High)**

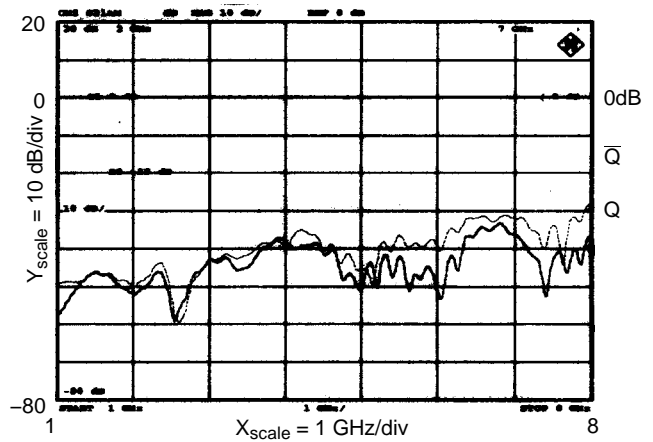
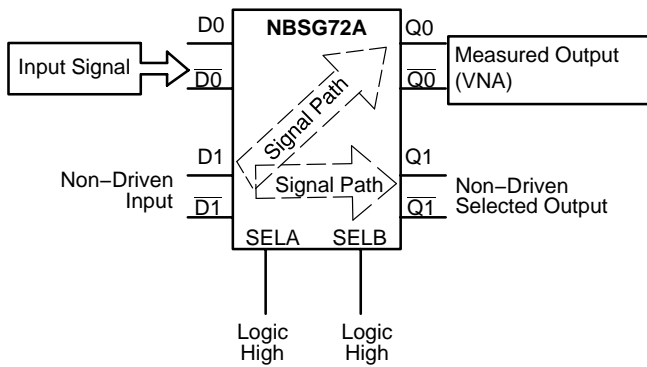


**Figure 5. Channel-to-Channel Crosstalk Isolation at Ambient Temperature (D1 to Q0 Signal Path Selected; SelA = High, SelB = Low)**

# NBSG72A

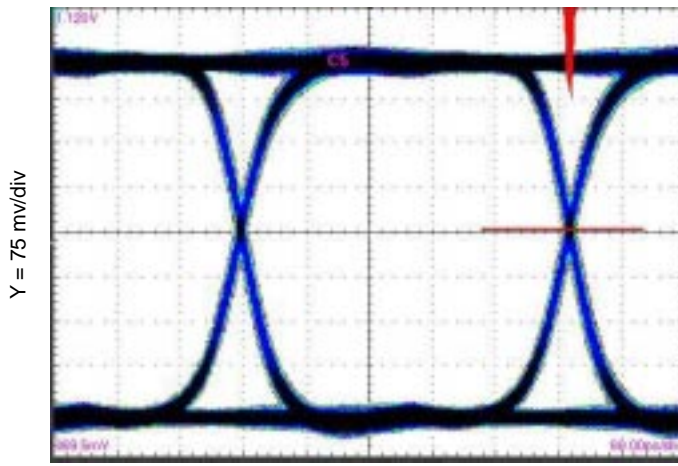


**Figure 6. Channel-to-Channel Crosstalk Isolation at Ambient Temperature (D0 to Q0 and Q1 Signal Path Selected; SelA = Low, SelB = Low)**



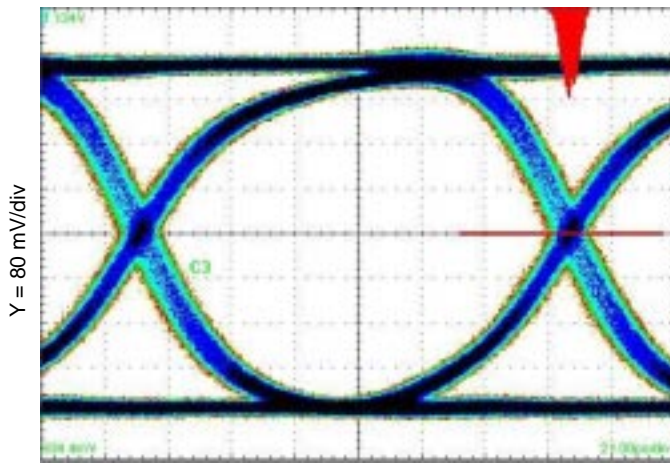
**Figure 7. Channel-to-Channel Crosstalk Isolation at Ambient Temperature (D1 to Q0 and Q1 Signal Path Selected; SelA = High, SelB = High)**

# NBSG72A



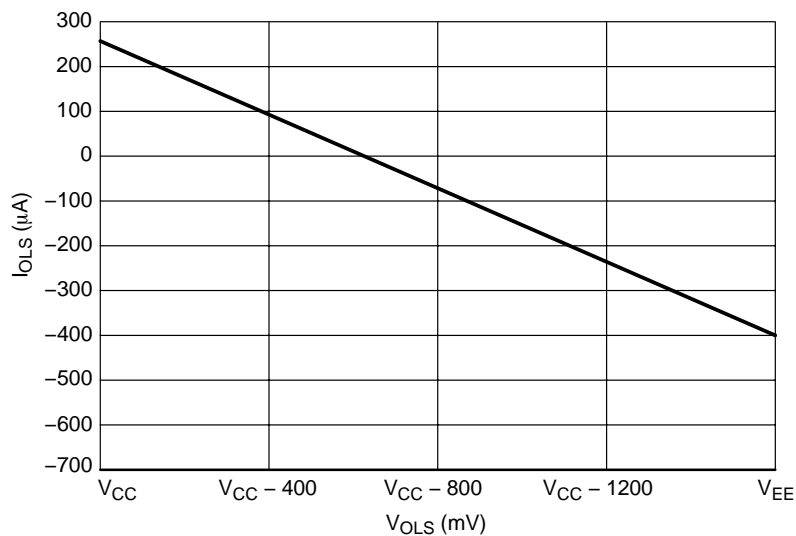
Total System Jitter = 17.2 ps  
 Input Generator Jitter = 10 ps  
 Device Jitter = 6.8 ps

**Figure 8. Eye Diagram at 3.2 Gb/s**  
 ( $V_{CC} - V_{EE} = 3.3\text{ V}$ , OLS = FLOAT @ 25°C with input pattern of  $2^{31}-1$  PRBS, 5000 Waveforms)



Total System Jitter = 17.2 ps  
 Input Generator Jitter = 10 ps  
 Device Jitter = 7.2 ps

**Figure 9. Eye Diagram at 7 GBit/s**  
 ( $V_{CC} - V_{EE} = 3.3\text{ V}$ , OLS = FLOAT @ 25°C with input pattern of  $2^{31}-1$  PRBS, 5000 Waveforms)



**Figure 10. Typical OLS Input Current vs. OLS Input Voltage**  
 ( $V_{CC} - V_{EE} = 3.3\text{ V}$  @ 25°C)

# NBSG72A

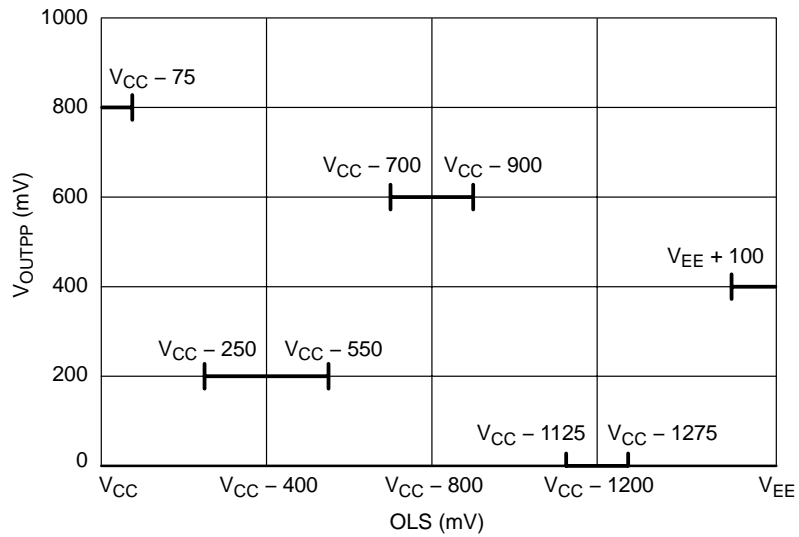


Figure 11. OLS Operating Area

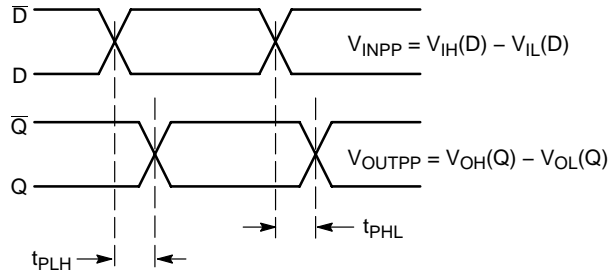


Figure 12. AC Reference Measurement

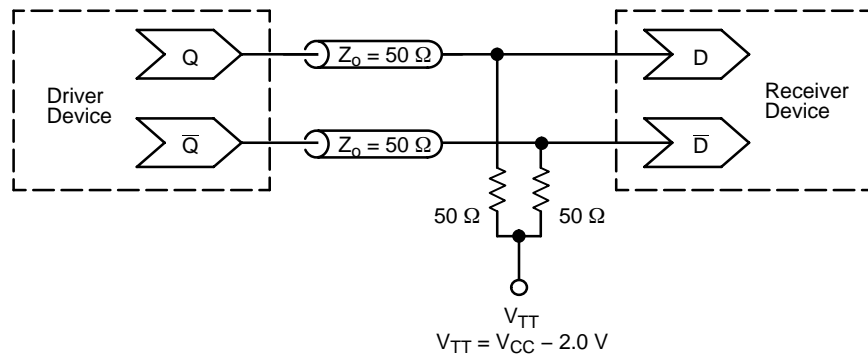


Figure 13. Typical Termination for Output Driver and Device Evaluation  
(See Application Note AND8020/D – Termination of ECL Logic Devices.)

## NBSG72A

### ORDERING INFORMATION

Device	Package	Shipping†
NBSG72AMN	QFN-16	123 Units / Rail
NBSG72AMNG	QFN-16 (Pb-Free)	123 Units / Rail
NBSG72AMNR2	QFN-16	3000 / Tape & Reel

Board	Description
NBSG72AMNEVB	NBSG72AMN Evaluation Board

†For information on tape and reel specifications, including part orientation and tape sizes, please refer to our Tape and Reel Packaging Specifications Brochure, BRD8011/D.

## NBSG72A

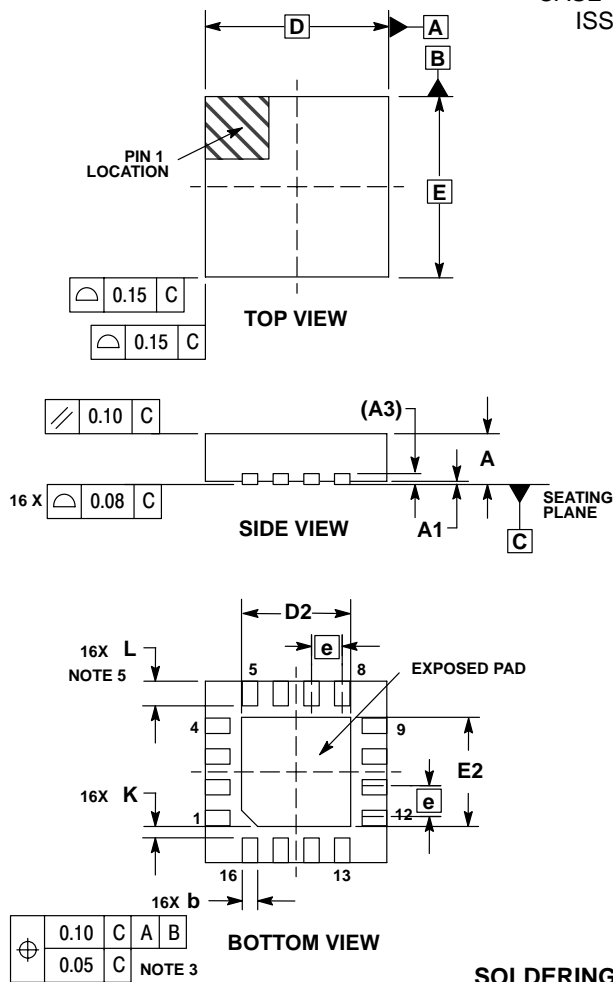
### Resource Reference of Application Notes

- AN1405/D** – ECL Clock Distribution Techniques
- AN1406/D** – Designing with PECL (ECL at +5.0 V)
- AN1503/D** – ECLinPS™ I/O SPICE Modeling Kit
- AN1504/D** – Metastability and the ECLinPS Family
- AN1568/D** – Interfacing Between LVDS and ECL
- AN1642/D** – The ECL Translator Guide
- AND8001/D** – Odd Number Counters Design
- AND8002/D** – Marking and Date Codes
- AND8020/D** – Termination of ECL Logic Devices
- AND8066/D** – Interfacing with ECLinPS
- AND8090/D** – AC Characteristics of ECL Devices

# NBSG72A

## PACKAGE DIMENSIONS

16 PIN QFN  
MN SUFFIX  
CASE 485G-01  
ISSUE B

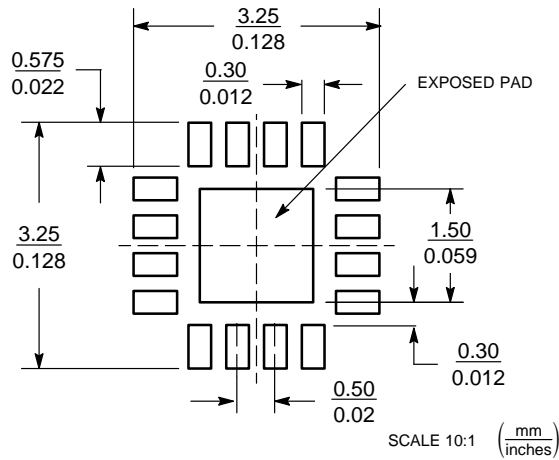


**NOTES:**

1. DIMENSIONING AND TOLERANCING PER ASME Y14.5M, 1994.
2. CONTROLLING DIMENSION: MILLIMETERS.
3. DIMENSION b APPLIES TO PLATED TERMINAL AND IS MEASURED BETWEEN 0.25 AND 0.30 MM FROM TERMINAL.
4. COPLANARITY APPLIES TO THE EXPOSED PAD AS WELL AS THE TERMINALS.
5. L<sub>max</sub> CONDITION CAN NOT VIOLATE 0.2 MM MINIMUM SPACING BETWEEN LEAD TIP AND FLAG

MILLIMETERS		
DIM	MIN	MAX
A	0.80	1.00
A1	0.00	0.05
A3	0.20 REF	
b	0.18	0.30
D	3.00 BSC	
D2	1.65	1.85
E	3.00 BSC	
E2	1.65	1.85
e	0.50 BSC	
K	0.20	---
L	0.30	0.50


### SOLDERING FOOTPRINT\*



\*For additional information on our Pb-Free strategy and soldering details, please download the ON Semiconductor Soldering and Mounting Techniques Reference Manual, SOLDERRM/D.

# NBSG72A

GigaComm is a trademark of Semiconductor Components Industries, LLC.

**ON Semiconductor** and  are registered trademarks of Semiconductor Components Industries, LLC (SCILLC). SCILLC reserves the right to make changes without further notice to any products herein. SCILLC makes no warranty, representation or guarantee regarding the suitability of its products for any particular purpose, nor does SCILLC assume any liability arising out of the application or use of any product or circuit, and specifically disclaims any and all liability, including without limitation special, consequential or incidental damages. "Typical" parameters which may be provided in SCILLC data sheets and/or specifications can and do vary in different applications and actual performance may vary over time. All operating parameters, including "Typicals" must be validated for each customer application by customer's technical experts. SCILLC does not convey any license under its patent rights nor the rights of others. SCILLC products are not designed, intended, or authorized for use as components in systems intended for surgical implant into the body, or other applications intended to support or sustain life, or for any other application in which the failure of the SCILLC product could create a situation where personal injury or death may occur. Should Buyer purchase or use SCILLC products for any such unintended or unauthorized application, Buyer shall indemnify and hold SCILLC and its officers, employees, subsidiaries, affiliates, and distributors harmless against all claims, costs, damages, and expenses, and reasonable attorney fees arising out of, directly or indirectly, any claim of personal injury or death associated with such unintended or unauthorized use, even if such claim alleges that SCILLC was negligent regarding the design or manufacture of the part. SCILLC is an Equal Opportunity/Affirmative Action Employer. This literature is subject to all applicable copyright laws and is not for resale in any manner.

## PUBLICATION ORDERING INFORMATION

### LITERATURE FULFILLMENT:

Literature Distribution Center for ON Semiconductor  
P.O. Box 61312, Phoenix, Arizona 85082-1312 USA  
**Phone:** 480-829-7710 or 800-344-3860 Toll Free USA/Canada  
**Fax:** 480-829-7709 or 800-344-3867 Toll Free USA/Canada  
**Email:** orderlit@onsemi.com

**N. American Technical Support:** 800-282-9855 Toll Free  
USA/Canada

**Japan:** ON Semiconductor, Japan Customer Focus Center  
2-9-1 Kamimeguro, Meguro-ku, Tokyo, Japan 153-0051  
**Phone:** 81-3-5773-3850

**ON Semiconductor Website:** <http://onsemi.com>

**Order Literature:** <http://www.onsemi.com/litorder>

For additional information, please contact your  
local Sales Representative.

## Looking for pricing, stock, or lifecycle information?

Click below to explore more details on WIN SOURCE:

- ⊖ [View NBSG72AMNEVB on WIN SOURCE](#)
- ⊖ [ON Semiconductor Information](#)

## Optimize Your Supply Chain with WIN SOURCE Solutions

- ✓ Global Sourcing Solution
- ✓ Obsolete Management
- ✓ Cost Control Management
- ✓ Shortage Management
- ✓ Alternative Solution
- ✓ Excess Inventory Management