



**THE DATASHEET OF
AISC-1210-2R7J-T**



SMD CERAMIC WIRE-WOUND INDUCTORS

AISC-1210-xxx



RoHS
Compliant



3.65 x 2.95 x 2.70mm

FEATURES:

- Exceptional high Q and SRF for high frequency applications
- Low DCR and high rated current
- Tight tolerances, many values at 2%
- Small size suitable for surface mounting
- Epoxy coating protects wound wire

APPLICATIONS:

- Widely used in mobile phones
- Bluetooth, W-LAN, Broadband Network
- High Frequency Communication Circuits
- Camcorders, TVs and other electronic devices

ELECTRICAL SPECIFICATIONS:

PARAMETERS

ABRACON P/N:	AISC-01210-xxx Series
Operating temperature	-40°C to +125°C
Storage temperature	-10°C to +40°C, 70% RH max.

Part Number AISC-1210- Inductance	Inductance	Tolerance	Min. Quality Factor	L/Q Test Freq.	Max. DC Resistance	Max. Rated Current	Min. Self-resonant Frequency
Units	nH	-	-	MHz	Ω	mA	MHz
Symbol	L	-	Q	Freq.	DCR	Ir	S.R.F
AISC-1210-3N9	3.9	J, K	30	100/300	0.05	1000	6000
AISC-1210-4N7	4.7	J, K	30	100/300	0.065	1000	5800
AISC-1210-8N2	8.2	J, K	30	100/300	0.07	1000	5500
AISC-1210-10N	10	G, J, K	40	100/300	0.08	1000	4000
AISC-1210-12N	12	G, J, K	40	100/300	0.08	1000	3200
AISC-1210-15N	15	G, J, K	40	100/300	0.10	1000	3200
AISC-1210-18N	18	G, J, K	50	100/300	0.10	1000	2800
AISC-1210-22N	22	G, J, K	50	100/300	0.10	1000	2200
AISC-1210-27N	27	G, J, K	50	100/300	0.11	1000	1800
AISC-1210-33N	33	G, J, K	55	100/300	0.11	1000	1800
AISC-1210-39N	39	G, J, K	55	100/300	0.12	1000	1500
AISC-1210-43N	43	G, J, K	55	100/300	0.12	1000	1500
AISC-1210-47N	47	G, J, K	55	100/300	0.13	1000	1500
AISC-1210-56N	56	G, J, K	55	100/300	0.14	1000	1450
AISC-1210-68N	68	G, J, K	55	100/300	0.15	900	1200
AISC-1210-82N	82	G, J, K	55	100/300	0.20	900	1000
AISC-1210-R10	100	G, J, K	55	100/300	0.20	850	900
AISC-1210-R12	120	G, J, K	60	100/300	0.25	800	800
AISC-1210-R15	150	G, J, K	60	100/300	0.25	750	700
AISC-1210-R18	180	G, J, K	60	50/300	0.30	700	650
AISC-1210-R22	220	G, J, K	60	50/300	0.40	770	650
AISC-1210-R27	270	G, J, K	40	50/300	0.40	630	580
AISC-1210-R33	330	G, J, K	45	50/150	0.58	590	580
AISC-1210-R39	390	G, J, K	45	50/150	0.58	530	510
AISC-1210-R47	470	G, J, K	45	50/150	0.80	490	480
AISC-1210-R56	560	G, J, K	45	35/150	1.10	460	420



SMD CERAMIC WIRE-WOUND INDUCTORS

AISC-1210-xxx



RoHS
Compliant



3.65 x 2.95 x 2.70mm

Key Electrical Specifications (Con'd)

Part Number AISC-0603-	Inductance	Tolerance	Min. Quality Factor	L/Q Test Freq.	Max. DC Resistance	Max. Rated Current	Min. Self-resonant Frequency
Units	nH	-	-	MHz	Ω	mA	MHz
Symbol	L	-	Q	Freq.	DCR	Ir	S.R.F
AISC-1210-R68	680	G, J, K	45	35/150	1.20	430	400
AISC-1210-R82	820	G, J, K	45	35/150	1.82	400	370
AISC-1210-1R0	1000	G, J, K	45	35/150	1.85	320	340
AISC-1210-1R2	1200	G, J, K	35	35/150	1.87	300	220
AISC-1210-1R5	1500	G, J, K	20	7.9/50	1.95	310	160
AISC-1210-1R8	1800	G, J, K	30	7.9/50	2.25	310	160
AISC-1210-2R2	2200	G, J, K	25	7.9/50	2.41	310	130
AISC-1210-2R7	2700	G, J, K	25	7.9/50	2.85	300	110
AISC-1210-3R0	3000	G, J, K	20	7.9/25	3.12	300	110
AISC-1210-3R9	3900	G, J, K	20	7.9/25	3.60	290	60
AISC-1210-4R7	4700	G, J, K	20	7.9/25	4.00	280	60
AISC-1210-5R6	5600	G, J, K	15	7.9/25	5.00	250	50
AISC-1210-6R8	6800	G, J, K	15	7.9/7.9	8.00	230	40
AISC-1210-8R6	8600	G, J, K	15	7.9/7.9	9.00	200	40

Test Conditions and Equipemnt

- Ambient Temperature: 20± 15°C
- Relative Humidity: 65%±20%
- Air Pressure: 86KPa to 106KPa

Inductance (L): Agilent4287A+Agilent16197A or equivalent, -13dBm or 10mA

Direct Current Resistance (DCR): HIOKI 3540 or equivalent

Q Factor (Q): Agilent4287A+Agilent16197A or equivalent, -13dBm or 10mA

Self-Resonant Frequency (SRF): Agilent4991B+Agilent16197A and HP 8753E or equivalent, -20dBm or 50mV

Rated Current (Ir): Ir is direct electric current as chip surface temperature rose just 20°C against chip initial surface temperature (Ta)

ELECTRICAL CHARACTERISTICS CURVES

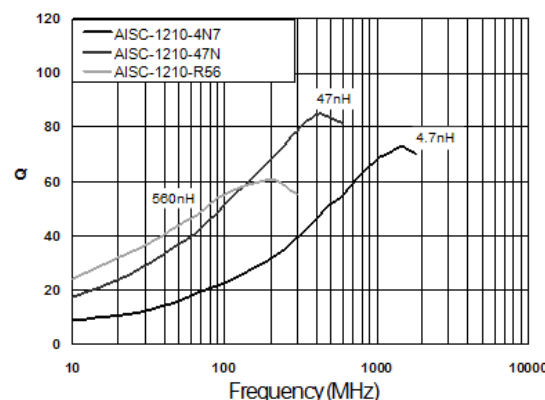
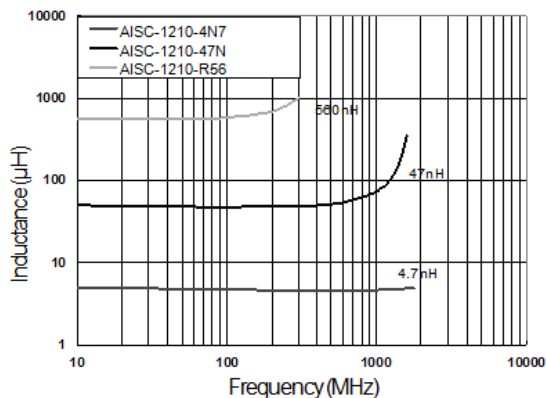

SMD CERAMIC WIRE-WOUND INDUCTORS

AISC-1210-xxx



RoHS
Compliant



3.65 x 2.95 x 2.70mm

PART IDENTIFICATIONS:

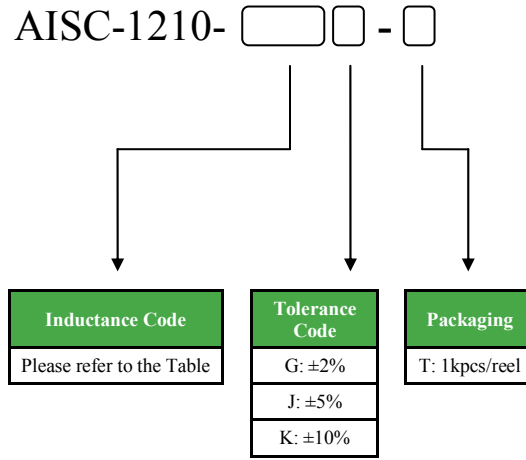

OUTLINE DIMENSIONS:

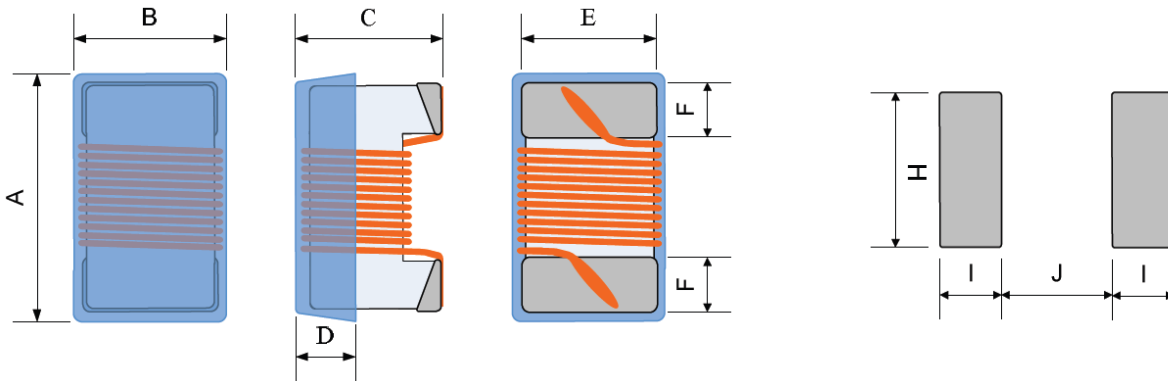

A MAX.	B MAX.	C MAX.	D REF.	E REF.	F REF.	H REF.	I REF.	J REF.
3.65	2.95	2.70	0.51	2.1±0.2	0.5±0.2	3.02	1.02	1.78

Materials

Dimension: mm

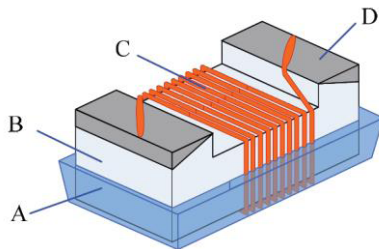

No.	Components	Material
A	Coating	Ultraviolet epoxy resin
B	Core	Ceramic
C	Wire	Polyurethane system enameled copper wire
D	Electrodes	Mo-Mn with Ni and Au plating



SMD CERAMIC WIRE-WOUND INDUCTORS

AISC-1210-xxx



RoHS
Compliant



3.65 x 2.95 x 2.70mm

REFLOW PROFILE:

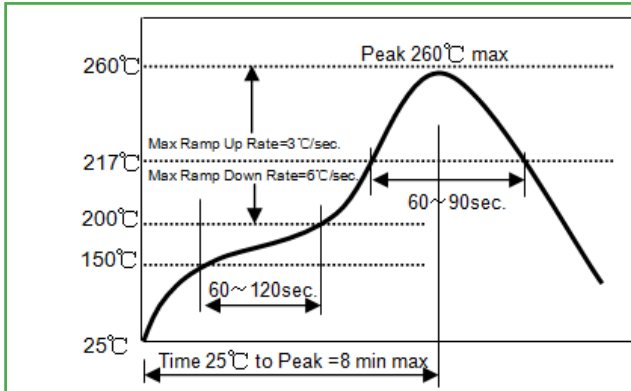

- Preheat condition: 150 ~200°C/60~120sec.
- Allowed time above 217°C: 60~90sec.
- Max temp: 260°C
- Max time at max temp: 10sec.
- Solder paste: Sn/3.0Ag/0.5Cu
- Allowed Reflow time: 2x max

TAPE & REEL:

T= tape and reel (1,000pcs/reel)

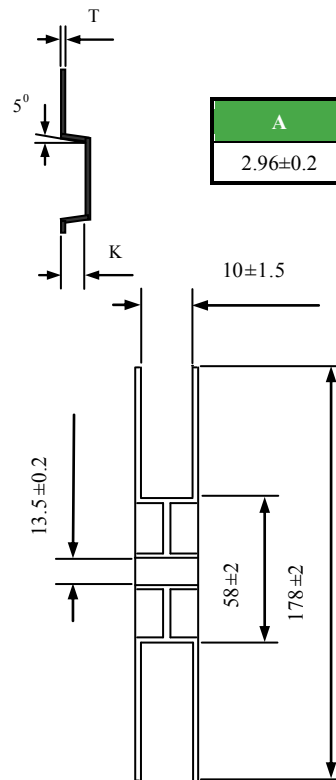
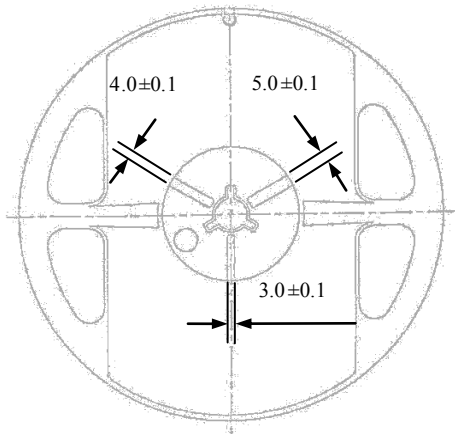
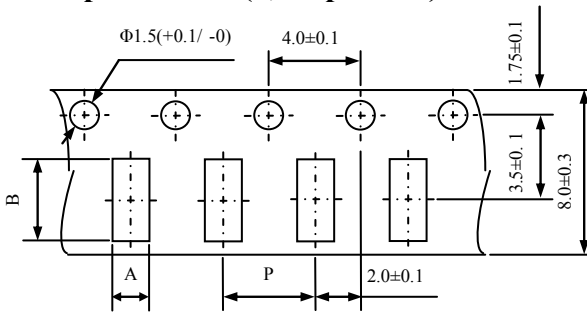

A	B	P	K Max	T
2.96±0.2	3.60±0.2	4.0±0.1	2.50±0.3	0.3±0.1

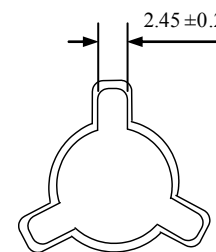

Dimension: mm

ATTENTION: Abracon Corporation's products are COTS – Commercial-Off-The-Shelf products; suitable for Commercial, Industrial and, where designated, Automotive Applications. Abracon's products are not specifically designed for Military, Aviation, Aerospace, Life-dependant Medical applications or any application requiring high reliability where component failure could result in loss of life and/or property. For applications requiring high reliability and/or presenting an extreme operating environment, written consent and authorization from Abracon Corporation is required. Please contact Abracon Corporation for more information.

ABRACON IS
ISO 9001 / QS 9000
CERTIFIED



Visit www.abracon.com for Terms & Conditions of Sale
30332 Esperanza, Rancho Santa Margarita, California 92688
tel 949-546-8000 | fax 949-546-8001 | www.abracon.com

Revised: 12.28.12

Looking for pricing, stock, or lifecycle information?

Click below to explore more details on WIN SOURCE:

 [View AISC-1210-2R7J-T on WIN SOURCE](#)

 [Abracon LLC Information](#)

Optimize Your Supply Chain with WIN SOURCE Solutions

-  Global Sourcing Solution
-  Obsolete Management
-  Cost Control Management
-  Shortage Management
-  Alternative Solution
-  Excess Inventory Management