



**THE DATASHEET OF
ELC-3GN470M**



Sincom

ISSUED BY

25 FEB 2005

SINCOM
INDUCTIVE TECH.

Approval Specifications

CUSTOMER : Digi Key
PART NAME : CHIP CHOKE COIL
CUSTOMER PART No. : ELC3GN□□□□
MATSUSHITA PART No. : ELC3GN□□□□
MODEL NAME / No. :
MANUFACTURED IN : INDONESIA

CUSTOMER'S ACKNOWLEDGEMENT

PLEASE RETURN ONE COPY

MATSUSHITA ELECTRONIC COMPONENTS (S) PTE. LTD.



No. 3 BEDOK SOUTH ROAD, SINGAPORE 469269

FAX : 62418954

TEL : 62495176

SPEC SERIAL NO.:

T1S - 05011

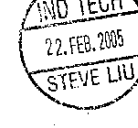
Approved	Checked	Prepared
		

21.05.03 (R-1)

TE-F-MP-18

1. この製品の使用材料は、「化学物質の審査及び製造等の規制に関する法律」に基づき、すべて既存化学物質として記載されている材料です。

All the materials used in this product are registered material under the Law Concerning the Examination and Regulation of Manufacture, etc. of Chemical Substances.

2. 本製品は、モントリオール議定書で規制されているオゾン層破壊物質(ODC)を製造工程及び購入部品・材料で一切使用していません。

This product has not been manufactured with any ozone depleting chemical controlled under the Montreal Protocol.

3. この製品に使用している全ての材料には、臭素系特定難燃物質「PBBOs、PBBs」を含有していません。

All the materials used in this product contain no brominated materials of PBBOs or PBBs as the flame-retardant.

4. 納入仕様書の「有効期間」について
有効期間は、特に、申し出のない限り(お客様の要望を含み)自動更新とします。
その際、連絡書・仕様書は、発行致しません。

"The Term of Validity" of Product Specifications for Information
Unless otherwise requested (including from customer), the term of validity shall be renewed automatically.

Then , informations and specifications shall be not issued.

5. Refer to "113-TEC-001" for ERS issues

SPECIFICATION (APPEARANCE)

(R-0)

151-ELC3-001

Part Name

CHIP CHOKE COIL (ELC3GN TYPE)

1 - 1

Apperance & Dimensions (Unit:mm)

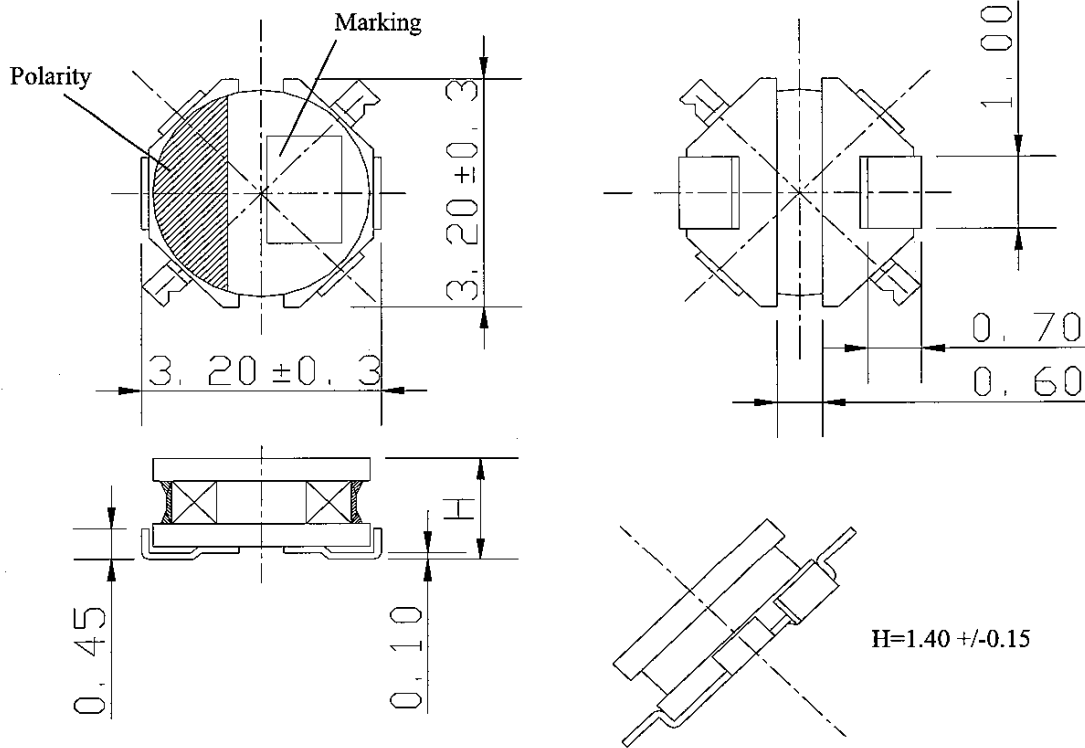

Recommended Land Patterns (Top view)

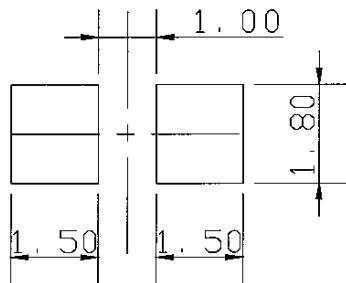

Part Number

MATSUSHITA'S P/N

ELC3 N M
 1 2 3 4

1	Height	G: 1.35+0.15/-0.15mm		
2	Inductance	2.7uH: 2R7	22uH: 220	100uH: 101
3	Tolerance	M: +20/-20%	N: +30/-30%	
4	Customer division			

Date Feb. 17. 2005

INDUCTIVE DEPARTMENT

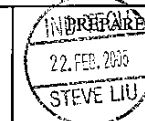
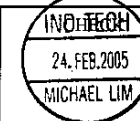
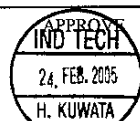

SPECIFICATION

(R- 0)

151-ELC3-006

Part Name

CHIP CHOKE COIL (ELC3GN TYPE)

1 - 1

Electrical Characteristics

CUSTOMER'S PART NUMBER	MATSUSHITA'S PART NUMBER	INDUCTANCE		DCR(20degC)		*RATED CURRENT [mA]	MARKING
		NOMINAL [uH]	TOL.	NOMINAL [ohm]	TOL.		
ELC3GN1R0N	ELC3GN1R0N	1	±30%	0.64	±20%	1300	A
ELC3GN1R6N	ELC3GN1R6N	1.6		0.83		1200	C
ELC3GN2R2N	ELC3GN2R2N	2.2		0.10		1000	D
ELC3GN3R3N	ELC3GN3R3N	3.3		0.13		970	E
ELC3GN4R7N	ELC3GN4R7N	4.7		0.20		760	H
ELC3GN6R8N	ELC3GN6R8N	6.8		0.25		680	K
ELC3GN8R2N	ELC3GN8R2N	8.2		0.41		540	L
ELC3GN100M	ELC3GN100M	10		0.43		530	M
ELC3GN150M	ELC3GN150M	15	0.60	430		O	
ELC3GN220M	ELC3GN220M	22	0.95	330		R	
ELC3GN330M	ELC3GN330M	33	1.40	280		T	
ELC3GN470M	ELC3GN470M	47	1.95	240		V	
ELC3GN680M	ELC3GN680M	68	3.00	190		X	

***Rated Current**

The maximum allowable current is a DC current which causes a 30% inductance reduction from its nominal value or coil temperature to rise 45degC whichever smaller.

(Reference ambient temperature 20degC)

TEST CONDITION (INDUCTANCE)

100kHz, 0.3Vrms

SPECIFICATION

CHIP CHOKE COIL RELIABILITY CHARACTERISTICS

(R-1)

151-ELL4-022

1 - 1

ITEM	SPECIFICATION	TEST METHOD / CONDITION	
Appearance And Structure	(1) The appearance shall be no damage practically harmful. (2) Other items shall be in accordance with the appearance and the structure in the individual specification.		
Insulation Resistance	More than 100 [Mohm]	After applying DC 100[V].	
Withstand Voltage	There shall be no abnormal.	After applying DC 100V for 60 [s]. Between core and coil.	
Operating temp. range	-40 to 105 [degC] (Including self - temperature rise)		
ENVIRONMENTAL CHARACTERISTICS	Moisture Life	(1) There shall not be case deformation or change in appearance. (2) There shall be no shorting or disconnection.	With rated current applied, coil shall be subjected to 90 to 95% [RH] at 60 +/- 2 degC for 500 +/- 8 [h]. Measurements shall be made after 1[h] stabilization at room temperature.
	High Temp. Life	(1) There shall not be case deformation or change in appearance. (2) There shall be no shorting or disconnection.	With rated current applied, coil shall be stored at 85 +/- 2 [degC] for 500 +/- 8 [h]. Measurements shall be made after 1[h] stabilization at room temperature.
	Cold Resistance	Inductance shall not change more than +/- 10%	Coil shall be stored at -40 +/- 2 [degC] for 500 +/- 8 [h]. Measurements shall be made after 1 [h]. stabilization at room temperature.
	Heat Resistance	Inductance shall not change more than +/- 10%	Coil shall be stored at 85 +/- 2 [degC] for 500 +/- 8 [h]. Measurements shall be made after 1 [h]. stabilization at room temperature.
	Moisture Resistance	(1) Inductance shall not change more than +/- 10% (2) There shall be no abnormal in withstand voltage.	Coil shall be subjected to 95 to 95% RH at 60 +/- 2 [degC] for 500 +/- 8 [h]. Measurements shall be made after 1 [h]. stabilization at room temperature.
	Thermal Shock	(1) There shall not be case deformation or change in appearance. (2) Inductance shall not change more than +/- 10%	-40 +/- 2 degC (for 0.5h) <=> 85 +/- 2 degC (for 0.5h) 10 cycles. Measurements shall be made after 1 [h]. stabilization at room temperature.
	Temp. Characteristics	Inductance shall not change more than +/- 15%	-25 to 85 [degC] Standard: Values at 20 [degC] (at Idc=0 [A])
PHYSICAL CHARACTERISTICS	Vibration Resistance	(1) There shall not be case deformation or change in appearance. (2) Inductance shall not change more than +/- 10%	After vibrating at frequencies ranging from 10 to 55 [Hz] (10 to 55 to 10/min.) with amplitude for 1.5 [mm] for 2 +/- 0.1 [h] each X-Y-Z axis.
	Terminal Strength	Terminal shall not come out.	Pulling strength of terminal: 0.98[N] { 0.1kgf } for 30 [s]
	Solderability	Solder shall be attached more than 90% around the dipped portion.	After fluxing, coil shall be dipped in a melted solder bath (M705) at 255 +/- 5 [°C] for 3 +/- 0.5 [s]
	Soldering Heat Resistance	(1) There shall not be case deformation or change in appearance. (2) Inductance shall not change more than +/- 10%	The coil shall be subjected to reflow soldering 2 times. Measurements shall be made after 1 [h]. stabilization at room temperature. Reflow soldering: Preheating: 150 +/- 10 [°C] , 3 [min] . Solder dipping: 250 +/- 10 [°C] , 10 +/- 0.5 [s]

SPECIFICATION (COMMON)

(R - 1)

151-ELC3-003

CHIP CHOKE COIL PRECAUTION FOR USE OF THE COIL.

1 - 1

ITEM	CONTENTS	REMARKS
REFLOW SOLDERING	<p style="text-align: center;">HOT BLAST REFLOW FURNACE.</p> <p style="text-align: center;">Peak Temperature: 260degC max Time above 200degC: 80 sec max</p>	<p style="text-align: center;">PC board</p> <p style="text-align: center;">Products</p> <p style="text-align: center;">Testing point</p> <p style="text-align: center;">(Reflow soldering should be limited to 2times.)</p>
WASHING OF BOARD	When the soldered PC board washed by fleon or others, you are requested to contact engineering department as for washer and washing conditions advance.	
RESOLDERING WITH A SOLDERING IRON	The temperature of the tip of the soldering iron should be 300°C or less, 3 seconds. And resoldering with a soldering iron should be limited to 1 time, and after that should be cooling these.	
MOUNTING SIDE	External force must be less than 5.0 [N] : while mounting.	
OTHERS	The customer is requested to store the products at the normal temperature (-5°C to 35°C) and the normal humidity (85%RH max.) in the packages we supplied. The package shall not be exposed to direct sunlight and harmful gas, and care should be taken so as not cause dew.	

- 1 . Don't make space between the coil and PC board.
- 2 . Don't heap up the coil.
- 3 . Be careful not to pressing force to the terminal.
- 4 . Don't use the coil dipped on the floor.

DATE 24-Feb-2005

INDUCTIVE DEPARTMET

SPECIFICATION (MATERIAL)	(R-0)
Part Name	151-ELC3-004
CHIP CHOKE COIL (ELC3*N TYPE)	1 - 1

Structure

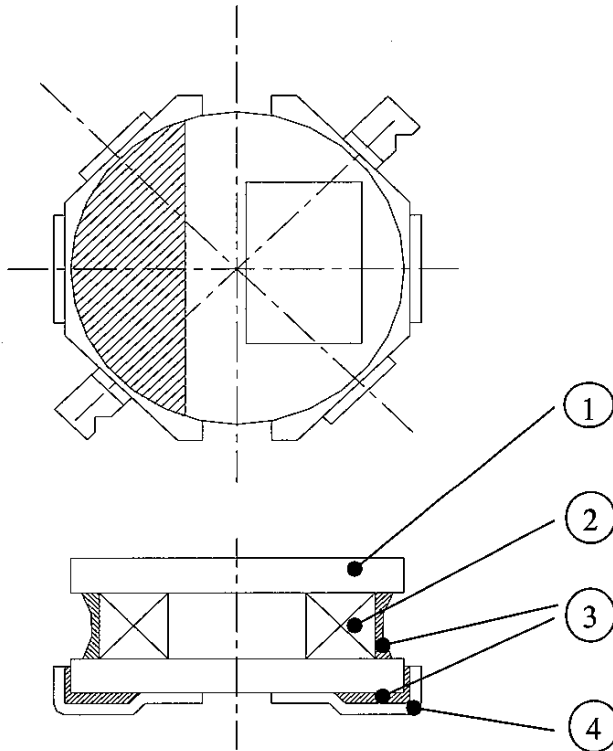

Material List

ITEM	PART NAME	MATERIALS	MANUFACTURE
1	Core	Ferrite	TDK CO.,LTD. HITACHI METALS LTD. FDK CO.,LTD. ZHEJIANG TIAN TONG ELECT. CO.,LTD HUOH YOW ENTERPRISE CO.,LTD
2	Coil	Polyurethane Enameled Copper Wire	RIKEN ELECTRIC WIRE CO.,LTD. TOUTOKU ELECTRIC CO.,LTD. DAIICHI DENKO CO.,LTD. HITACHI DENNSEN LTD.
3	Adhesive	Epoxy Resin	OPTIONAL
4	Terminal	Phosphor Bronze	OPTIONAL

Date Feb. 17. 2005	INDUCTIVE DEPARTMENT			
--------------------	----------------------	--	--	--

SPECIFICATION (PACKAGING)

(R - 0)

151-ELC3-005

Part Name

CHIP CHOKE COIL (ELC3GN TYPE)

2 - 1

Taping

(1) CARRIER TAPE DIMENSIONS.

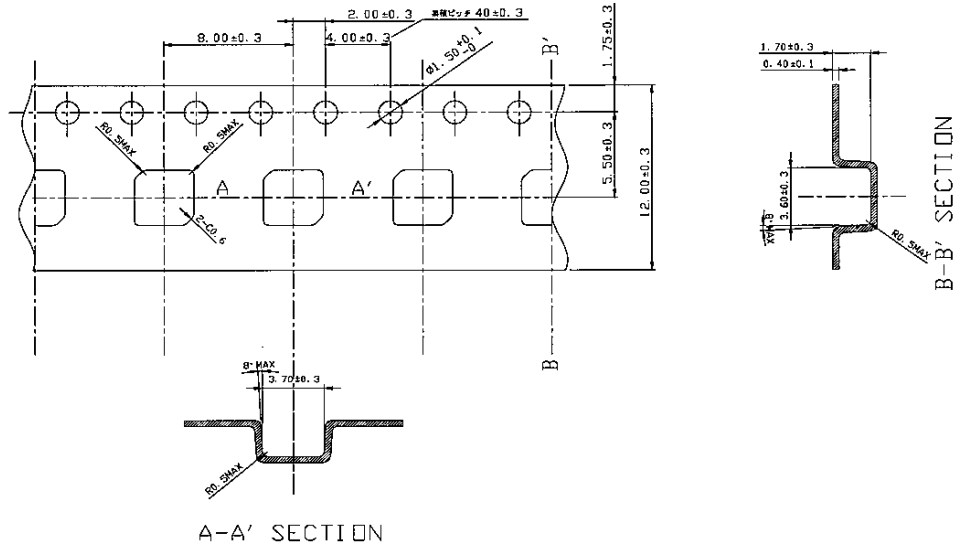

(2) COVER TAPE PEEL STRENGTH AND TEST METHOD

PEEL SPEED : 300mm/min
PEEL STRENGTH : 0.1 to 1.07N

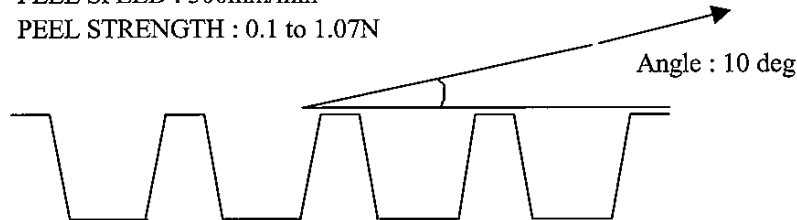

(3) PACKAGING

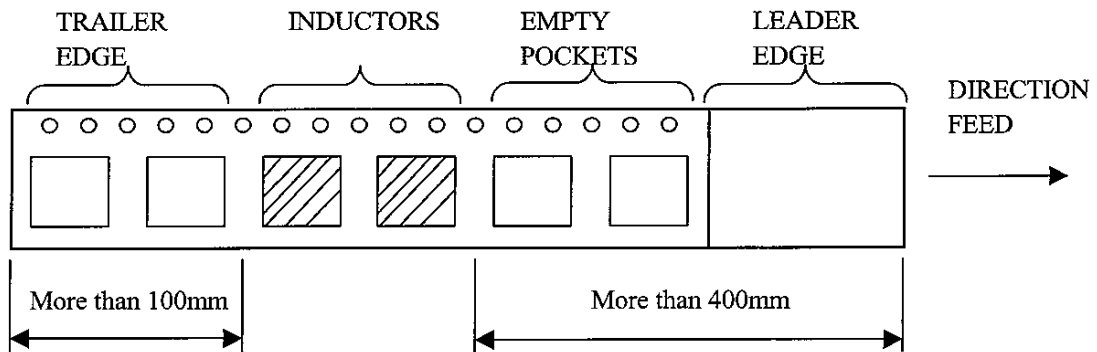

Date Feb. 17. 2005

INDUCTIVE DEPARTMENT

SPECIFICATION (PACKAGING)

(R-0)
151-ELC3-005

Part Name

CHIP CHOKE COIL (ELC3GN TYPE)

2 - 2

Taping

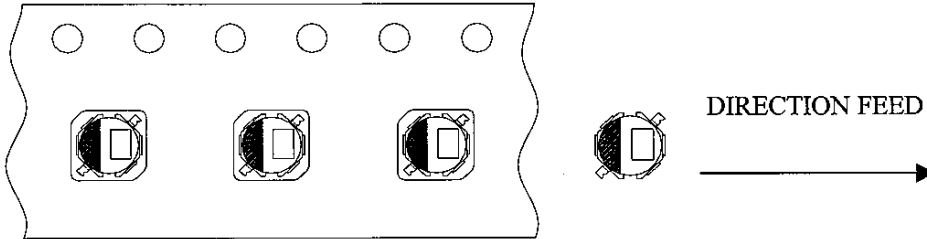

There shall not be more empty pockets than two and those pockets shall not be consecutive.

Reel Dimensions

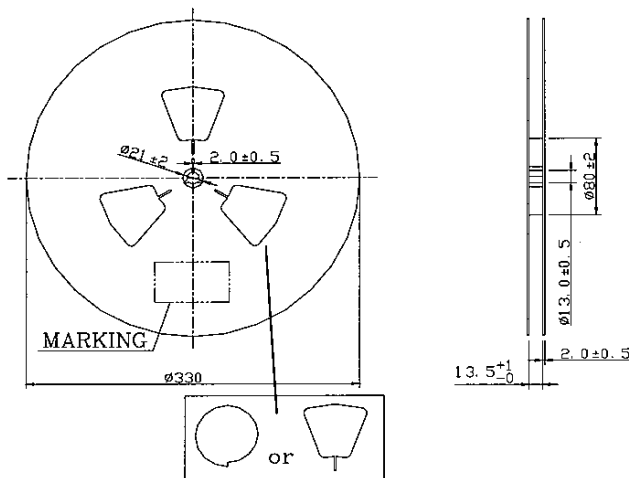

- (1) QUANTITY PER REEL: 2000pcs.
- (2) MARKING: CUSTOMER'S P/N,
OUR P/N, QUANTITY AND Lot No.

Packed Form

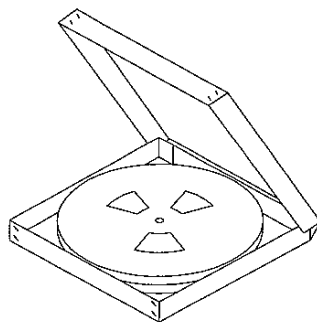

- (1) MARKING: CUSTOMER'S P/N,
OUR P/N, QUANTITY AND Lot No.

Material Use

Corrugated Card Board.

Date Feb. 17. 2005

INDUCTIVE DEPARTMENT

Looking for pricing, stock, or lifecycle information?

Click below to explore more details on WIN SOURCE:

 [View ELC-3GN470M on WIN SOURCE](#)

 [Panasonic Information](#)

Optimize Your Supply Chain with WIN SOURCE Solutions

-  Global Sourcing Solution
-  Obsolete Management
-  Cost Control Management
-  Shortage Management
-  Alternative Solution
-  Excess Inventory Management