



**THE DATASHEET OF
M310220**





Part No. M310220

Wi-Fi / BT / Zigbee or S-Band Ceramic Antenna

2.4 GHz

Supports: Wi-Fi applications, Bluetooth, Zigbee, WLAN, Satellite IoT



KYOCERA AVX's series of Ceramic Isolated Magnetic Dipole™ (IMD) antennas deliver on the key needs of device designers for higher functionality and performance in smaller/thinner designs. These innovative antennas provide compelling advantages for Bluetooth® enabled cell phones, media players and other mobile devices. Also covers S-Band for Satellite IoT Applications.

Real-World Performance and Implementation

Ceramic antennas may look alike on the outside, but the important difference is inside. Other antennas may contain simple PiFA or monopole designs that interact with their surroundings, complicating layout or changing performance with use position. KYOCERA AVX's antennas utilize patented IMD technology to deliver a unique size and performance combination.

Greater Flexibility

KYOCERA AVX's first-in-class IMD technology enables you to develop concept designs that are more advanced and that deliver superior performance in reception critical applications.

Electrical Specifications

Typical performance on 40 x 60 mm PCB

Frequency (MHz)	2400 – 2485	1980-2020	2170-2200
Peak Gain	1.7 dBi	Refer to Appendix 1	Refer to Appendix 1
Average Efficiency	67%		
VSWR Match	2.0:1 max		
Feed Point Impedance	50 ohms unbalanced		
Polarization	Linear		
Power Handling	0.5 Watt CW		

Mechanical Specifications & Ordering Part Number

Ordering Part Number	M310220
Size (mm)	3.00 x 1.50 x 1.08
Mounting	Surface mounted
Weight (grams)	0.1
Packaging	Tape & Reel, M310220 – 1,000 pieces per reel
Demo Board	M310220-01 (2.4 GHz) M310220-03 (S-band)

Ceramic Wi-Fi / Bluetooth Antenna or S-Band

2400 – 2485 MHz (Wi-Fi/BT)
 1980 – 2020 MHz (S-Band)
 2170 – 2200 MHz (S-Band)

KEY BENEFITS

Stay-in-Tune

IMD antenna technology provides superior RF field containment, resulting in less interaction with surrounding components.

Quicker Time-to-Market

By optimizing antenna size, performance and emissions, customer and regulatory specifications are more easily met.

Environmental Compliance

Products are the latest RoHS version compliant.

APPLICATIONS

- Embedded design
 - Headsets, Tablets
 - Gateway, Access Point
 - Handheld
 - Telematics
 - Healthcare
- Applications (FDA Class I)
 - M2M, Industrial devices
 - Smart Grid
 - OBD-II
 - Satellite IoT

2.4 GHz KYOCERA AVX's Embedded Antenna Specifications
 KYOCERA AVX's produces a wide variety of standard and custom antennas to meet user needs.

Antenna Dimensions

Typical antenna dimensions (mm)

Part Number	A (mm)	B (mm)	C (mm)
M310220	3.00 ± 0.2	1.50 ± 0.2	1.08 ± 0.1

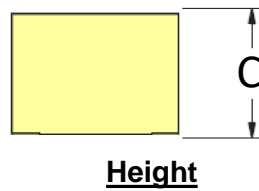
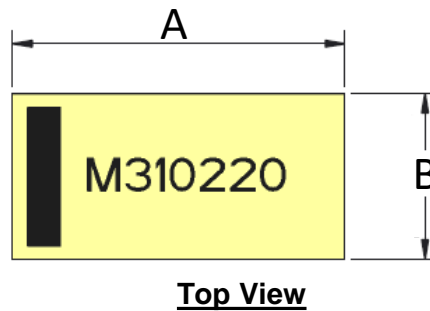
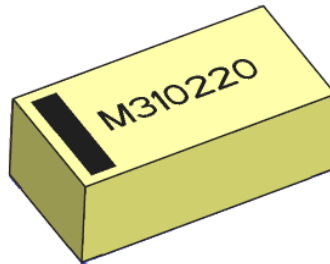

Pin	Description
1	Feed
2	Ground

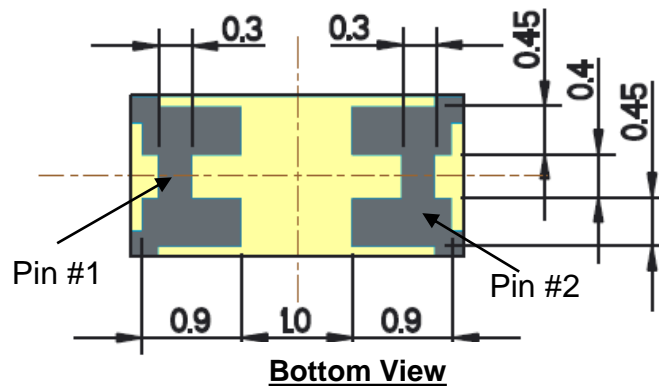

2.4 GHz KYOCERA AVX's' Embedded Antenna Specifications
 KYOCERA AVX's produces a wide variety of standard and custom antennas to meet user needs.

VSWR, Efficiency Plots

Typical performance on 40 x 60 mm PCB

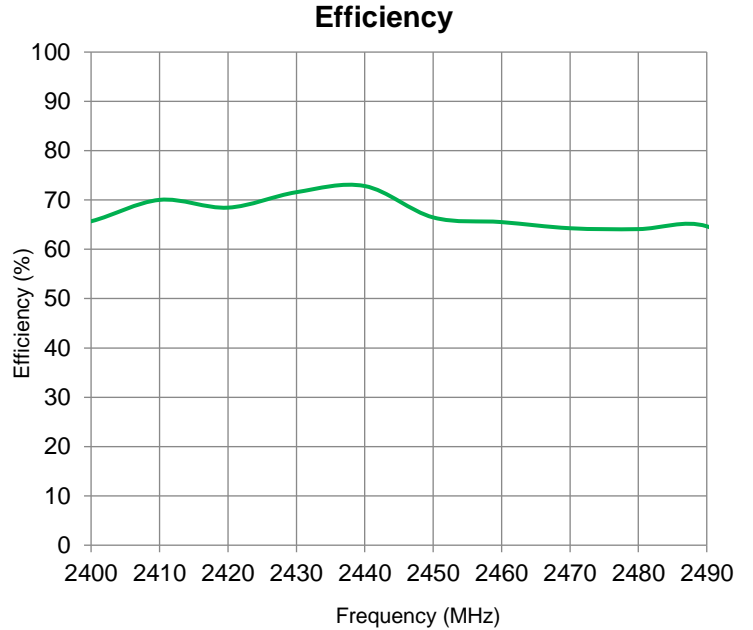
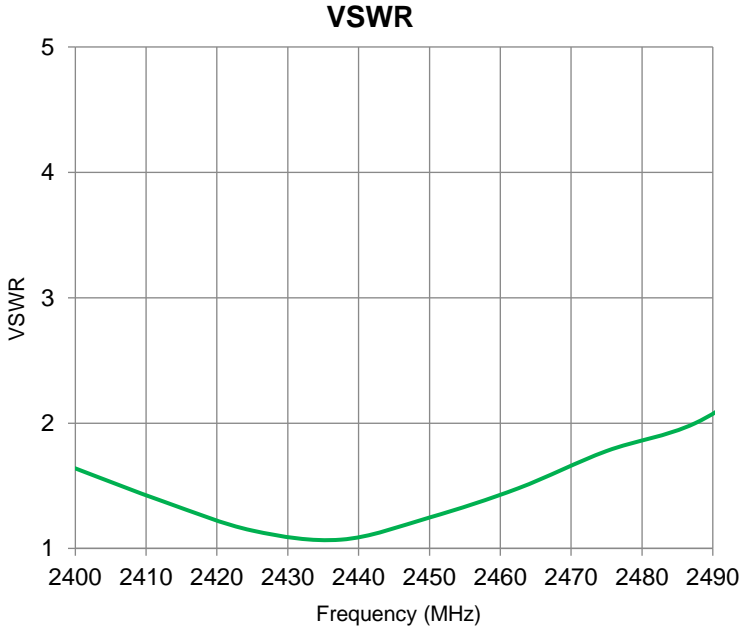

Antenna Radiation Patterns

Typical performance on 40 x 60 mm PCB
 Measured @ 2440 MHz

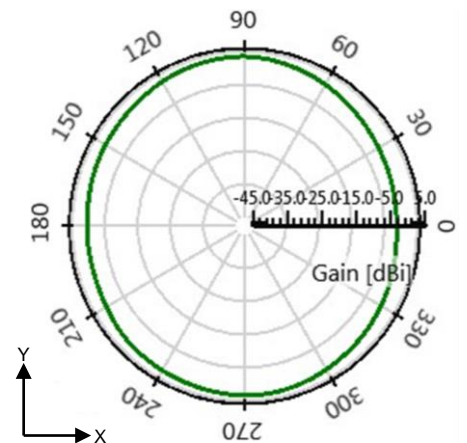
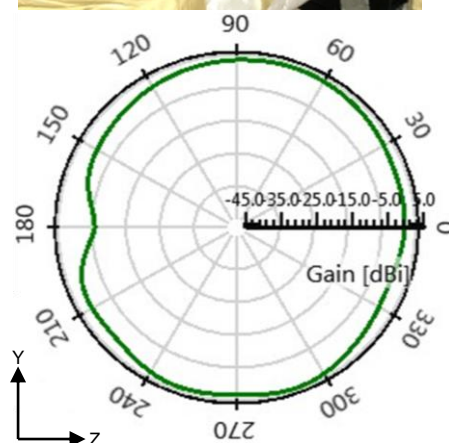
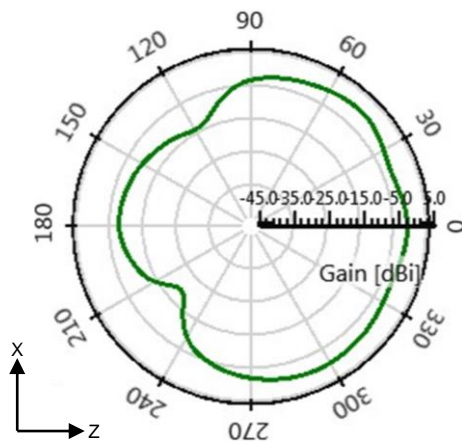
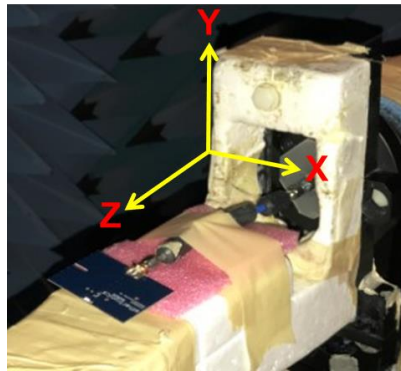

2.4 GHz KYOCERA AVX's' Embedded Antenna Specifications
 KYOCERA AVX's produces a wide variety of standard and custom antennas to meet user needs.

Antenna Layout

Typical layout dimensions (mm)

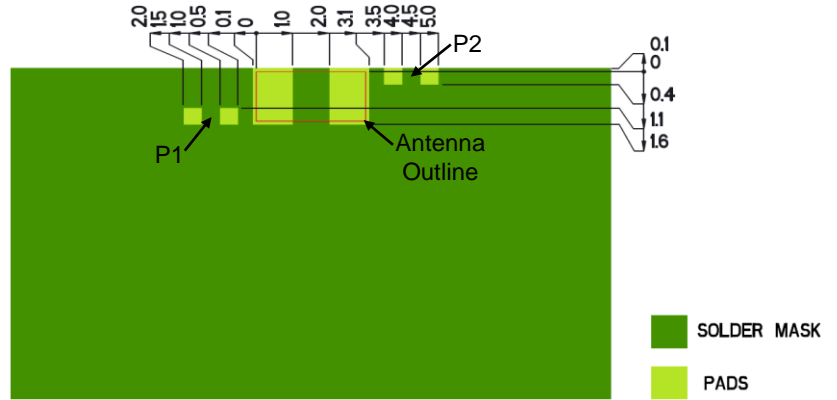
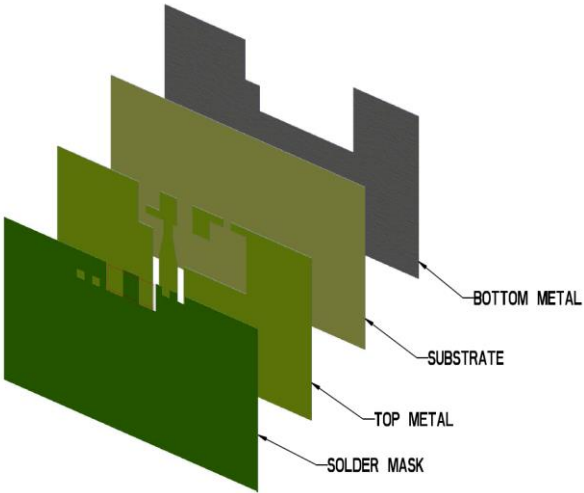

- Additional VIAS: Diam. 0.2mm to be placed around antenna, (no vias on transmission lines).
- Via holes must be covered by solder mask

Pin Descriptions

Pin#	Description
1	Feed
2	Ground

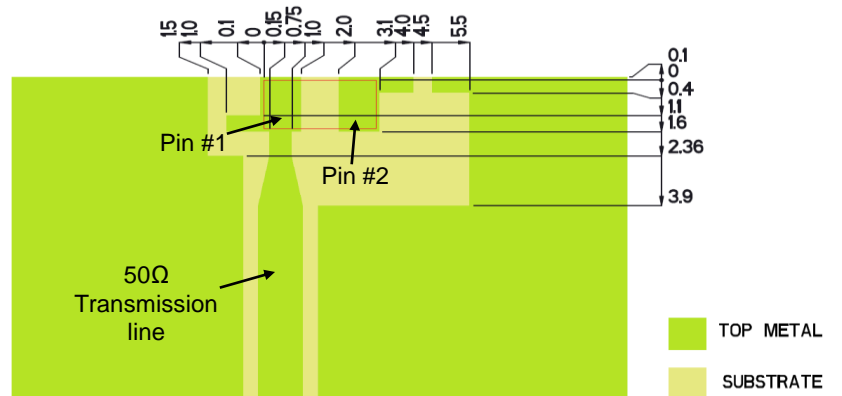

Matching Network (Demo Board)

Component	Value	Tolerance
P1	4.7pF	±0.05pF
P2	2.7pF	±0.05pF

*Actual matching values depend on customer design

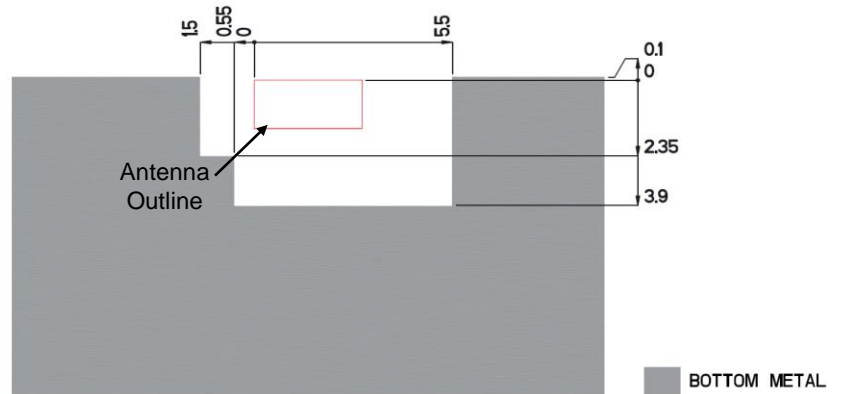
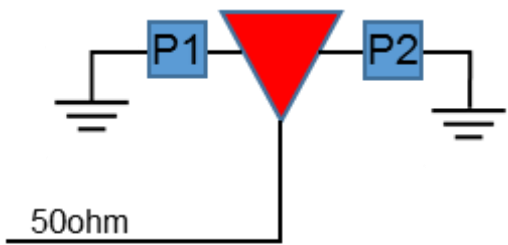

2.4 GHz KYOCERA AVX's' Embedded Antenna Specifications
 KYOCERA AVX's produces a wide variety of standard and custom antennas to meet user needs.

Antenna Layout Tips (General reference)

Important, layout guidelines for correct operation of KYOCERA AVX's Ceramic Antennas. Please read guidelines below before laying out the antenna in a device. Figure 1 shows the typical antenna layout. Figure 2 shows KYOCERA AVX's' antenna layout.

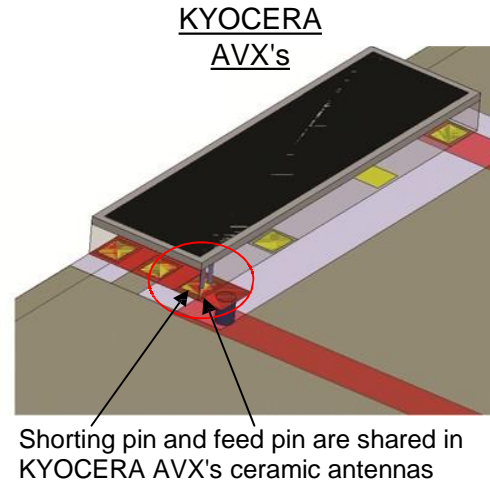
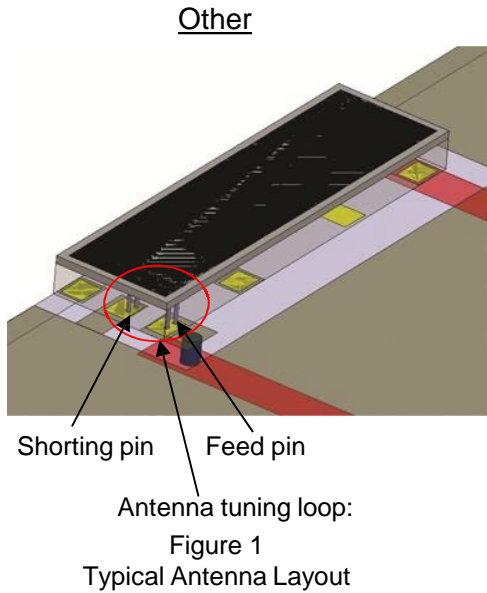

Figure 2
 KYOCERA AVX's Antenna
 Layout
 (Required)

- The antenna tuning loop is formed by the PCB layout.
- The feed pin and shorting pin are combined because it requires very close proximity to achieve more band- width.

2.4 GHz KYOCERA AVX's' Embedded Antenna Specifications
 KYOCERA AVX's produces a wide variety of standard and custom antennas to meet user needs.

Antenna Demo Board

Typical layout dimensions (mm)

Part Number	A (mm)	B (mm)	C (mm)
M310220-01	60.0	40.0	30.0

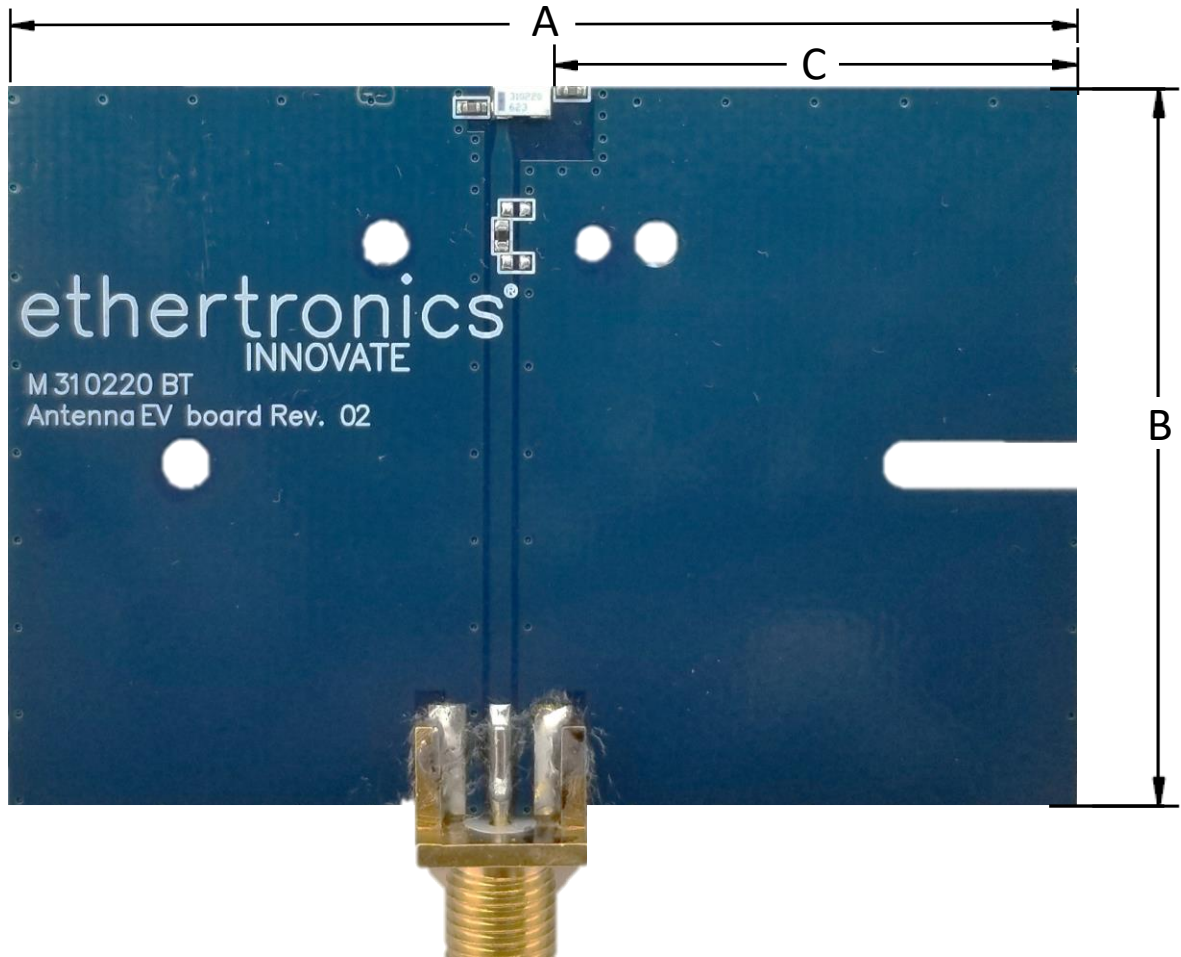

S-Band KYOCERA AVX's Embedded Antenna Specifications
 KYOCERA AVX's produces a wide variety of standard and custom antennas to meet user needs.

Appendix 1

Appendix 1 gives instructions on how to achieve the S-Band (1980 – 2020 MHz, 2170 – 2200 MHz)

Electrical Specifications

Typical Characteristics, using 60 x 40 mm PCB.

Bands (MHz)	1980-2020	2170-2200
Average Efficiency	40%	40%
Return Loss	< - 8dB	< - 5dB
Power handling	0.5 Watt CW	0.5 Watt CW
Feed Point Impedance	50Ω unbalanced	
Polarization	Linear	
Radiation Pattern	Omni-directional	

S-Band KYOCERA AVX's Embedded Antenna Specifications
 KYOCERA AVX's produces a wide variety of standard and custom antennas to meet user needs.

Return Loss, Efficiency Data

Typical M310220 performance dimensions (mm)

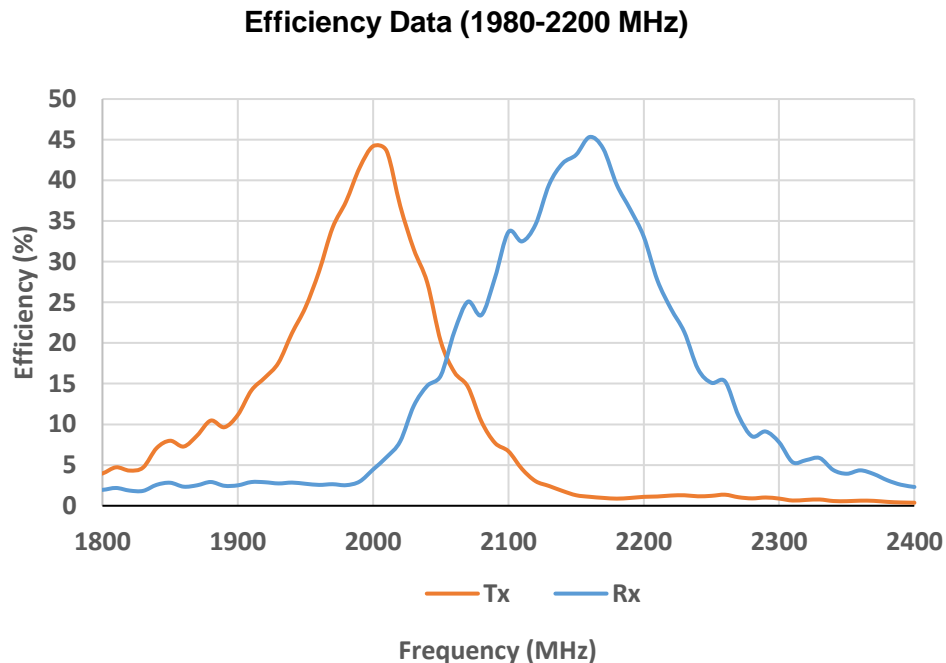
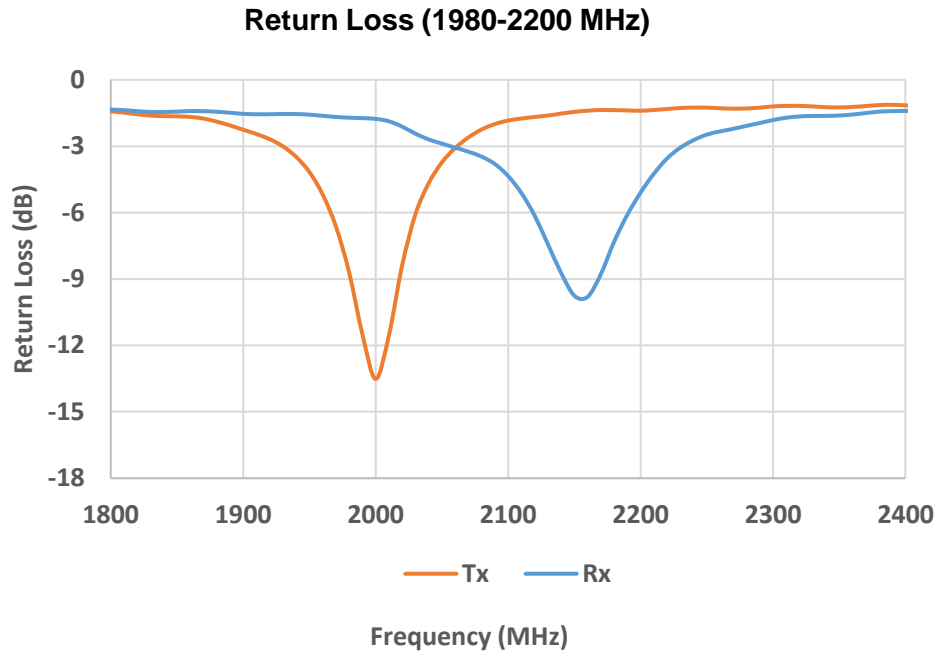

S-Band KYOCERA AVX's Embedded Antenna Specifications
 KYOCERA AVX's produces a wide variety of standard and custom antennas to meet user needs.

Low/ High Band Radiation Pattern

Typical performance M310220 performance in Free Space (2000-2180 MHz)

Position at phi = 0

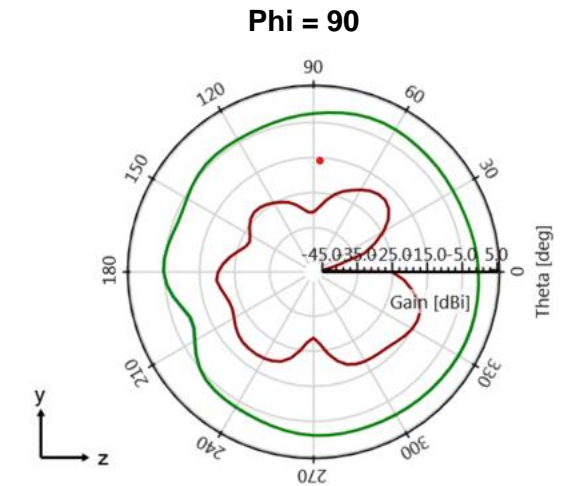
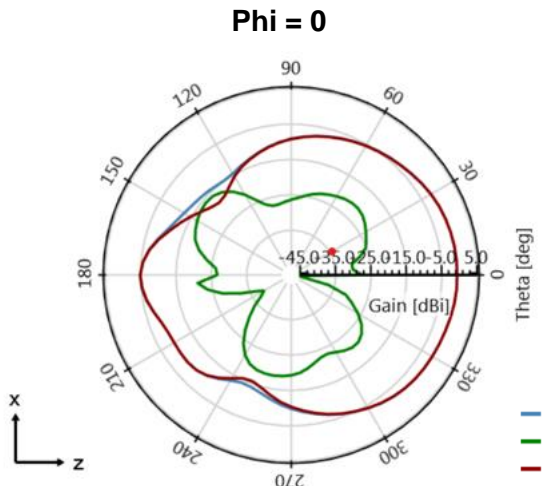
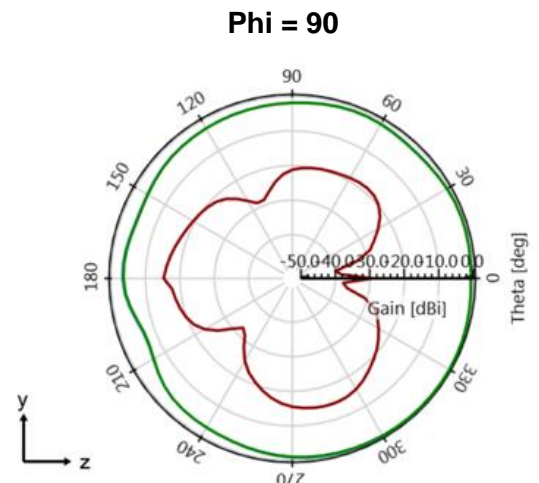
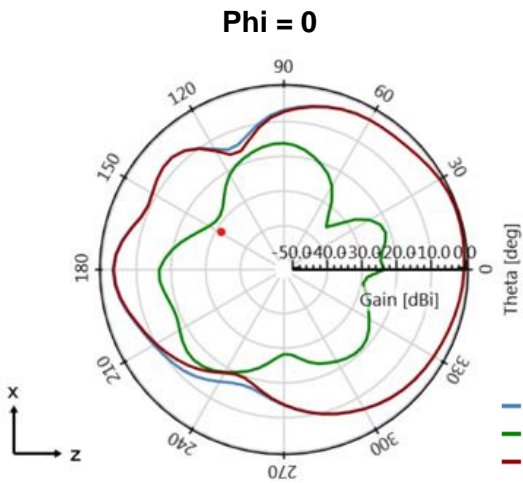
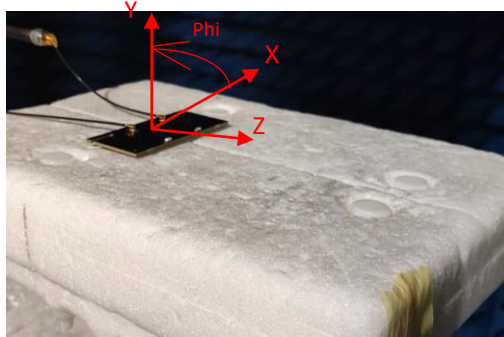

S-Band KYOCERA AVX's Embedded Antenna Specifications
 KYOCERA AVX's produces a wide variety of standard and custom antennas to meet user needs.

Mechanical Dimensions

Typical antenna dimensions (mm)

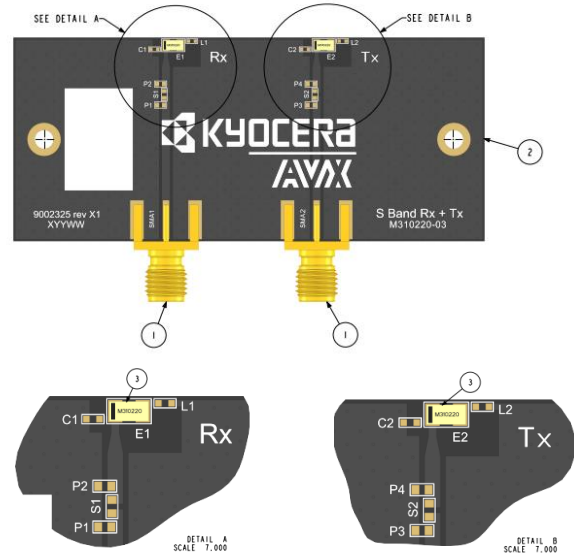
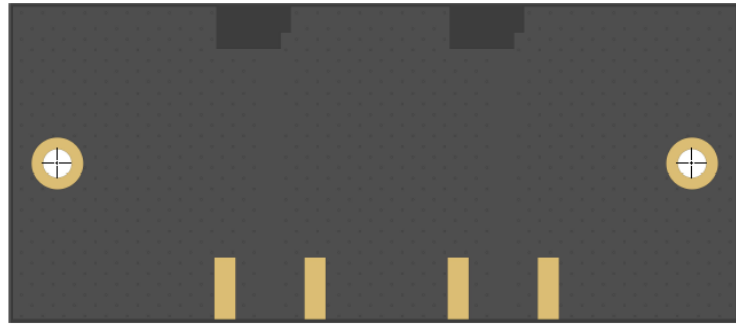
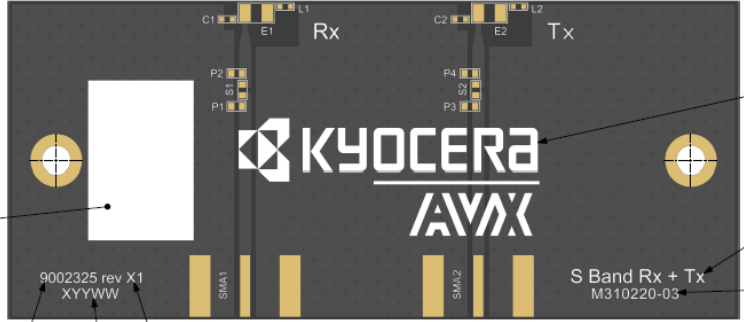

Top soldermask

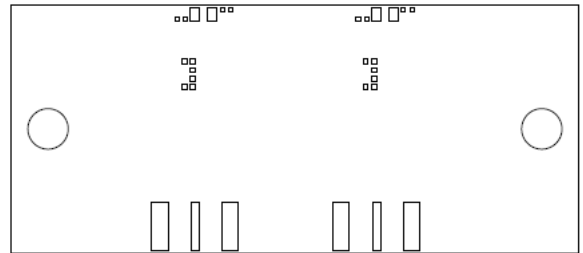

Top metal

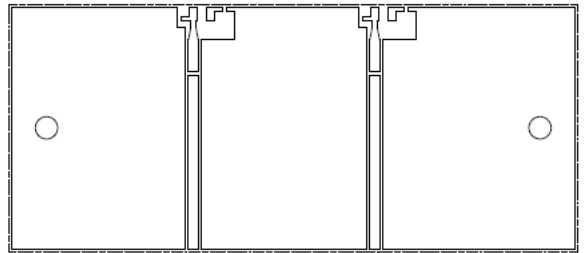

Bottom metal

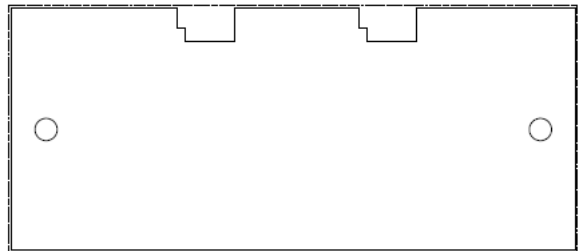

Bottom soldermask

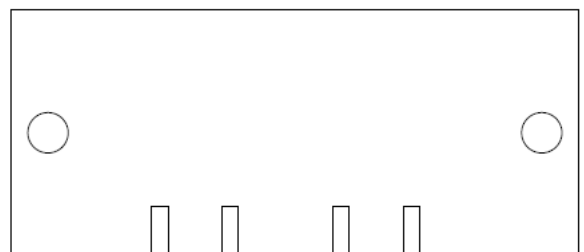

S-Band KYOCERA AVX's Embedded Antenna Specifications
 KYOCERA AVX's produces a wide variety of standard and custom antennas to meet user needs.

Antenna Demo Board Dimensions (M310220-03)

Typical Board dimensions (mm)

Part Number	A (mm)	B (mm)	C (mm)
M310220-03	69.00	30.00	0.80

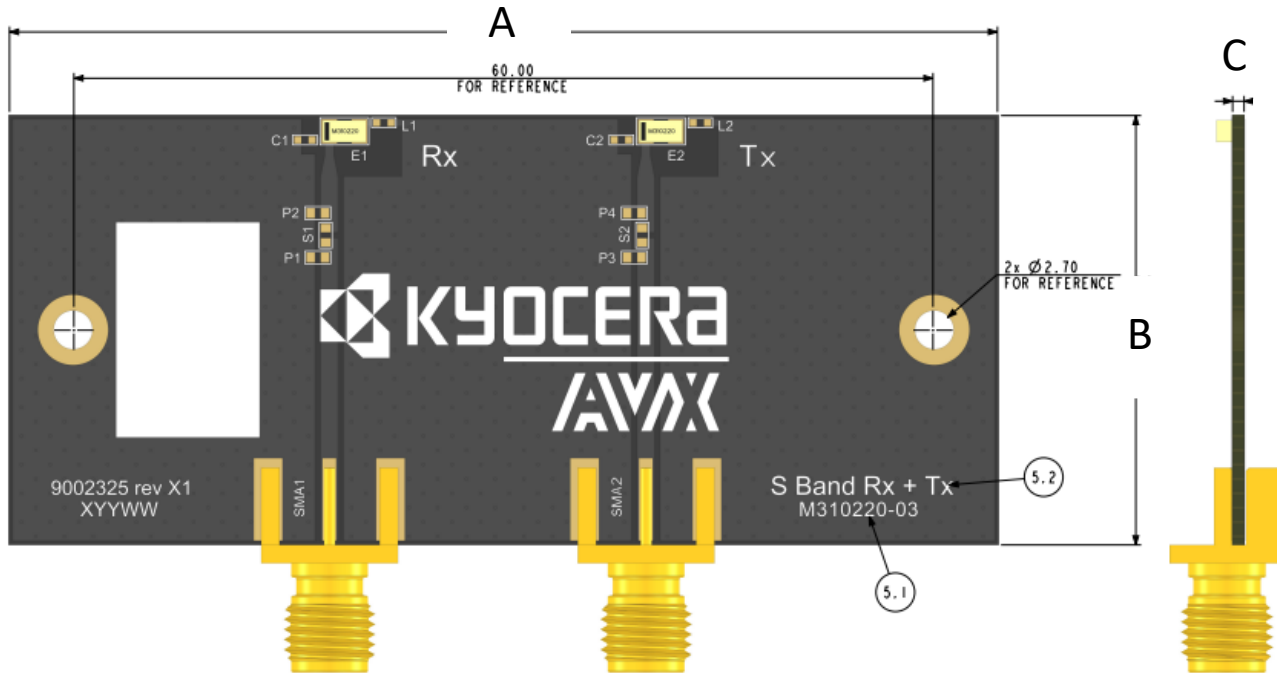

Looking for pricing, stock, or lifecycle information?

Click below to explore more details on WIN SOURCE:

 [View M310220 on WIN SOURCE](#)

 [Ethertronics/AVX Information](#)

Optimize Your Supply Chain with WIN SOURCE Solutions

-  Global Sourcing Solution
-  Obsolete Management
-  Cost Control Management
-  Shortage Management
-  Alternative Solution
-  Excess Inventory Management