



**THE DATASHEET OF
AS3418-EWLM**





Datasheet

DS000507

AS3418

Low Noise ANC Solution

v4-00 • 2020-Jan-23

Content Guide

| | | | |
|----------|--|-----------|--|
| 1 | General Description..... 3 | 6.8 | Operation Modes 33 |
| 1.1 | Key Benefits & Features 3 | 6.9 | V _{NEG} Charge Pump 38 |
| 1.2 | Applications 4 | 6.10 | EEPROM..... 39 |
| 1.3 | Block Diagram 4 | 6.11 | Production Trimming Interface..... 41 |
| 2 | Ordering Information..... 5 | 6.12 | I ² C Interface 42 |
| 3 | Pin Assignment 6 | 7 | Register Description 47 |
| 3.1 | Pin Diagram..... 6 | 7.1 | Register Overview..... 47 |
| 3.2 | Pin Description 6 | 7.2 | Detailed Register Description 49 |
| 4 | Absolute Maximum Ratings..... 9 | 8 | Application Information 70 |
| 5 | Electrical Characteristics 10 | 8.1 | Schematic 70 |
| 6 | Functional Description..... 12 | 8.2 | External Components 72 |
| 6.1 | Audio Line Input 12 | 9 | Package Drawings & Markings... 74 |
| 6.2 | Microphone Inputs..... 13 | 10 | Revision Information..... 76 |
| 6.3 | Microphone Supply 19 | 11 | Legal Information 77 |
| 6.4 | Headphone Amplifier..... 21 | | |
| 6.5 | Music Bypass Switch 25 | | |
| 6.6 | Operational Amplifier..... 28 | | |
| 6.7 | System 30 | | |

1 General Description

The AS3418 speaker driver with Ambient Noise Cancelling function for headsets, headphones or ear pieces. They are intended to improve quality of e.g. music listening, a phone conversation etc. by reducing background ambient noise.

The fully analog implementation allows the lowest power consumption, lowest system BOM cost and most natural received voice enhancement otherwise difficult to achieve with DSP implementations. The device is designed to be easily applied to existing architectures.

An internal EEPROM can be optionally used to store the microphones gain calibration settings. The AS3418 can be used in different configurations for best trade-off of noise cancellation, required filtering functions and mechanical designs.

The AS3418 targeting feed-forward topology is used to effectively reduce frequencies typically up to 2-3 kHz. The typical bandwidth for a feed-forward system is from 20Hz up to 3 kHz which is lower than the feed-forward systems.

The filter loop for the system is determined by measurements, for each specific headset individually, and depends very much on mechanical designs. The gain and phase compensation filter network is implemented with cheap resistors and capacitors for lowest system costs.

1.1 Key Benefits & Features

The benefits and features of AS3418, Low Noise ANC Solution, are listed below:

Figure 1:
Added Value of Using AS3418

| Benefits | Features |
|--------------------------------|---|
| Low Noise Floor | Low Noise Amplifiers |
| Integrated Music Bypass Switch | Depletion mode transistors for passive music bypass |
| Smallest ANC form factor | WL-CSP package 2.645mm x 2.545mm; 0.4mm pitch |
| Reprogrammable ANC settings | EEPROM Memory for system settings |

1.2 Applications

- Ear Pieces
- Headsets
- Hands-Free Kits
- Mobile Phones
- Voice Communicating Devices

1.3 Block Diagram

The functional blocks of this device are shown below:

Figure 2 :
Functional Blocks of AS3418

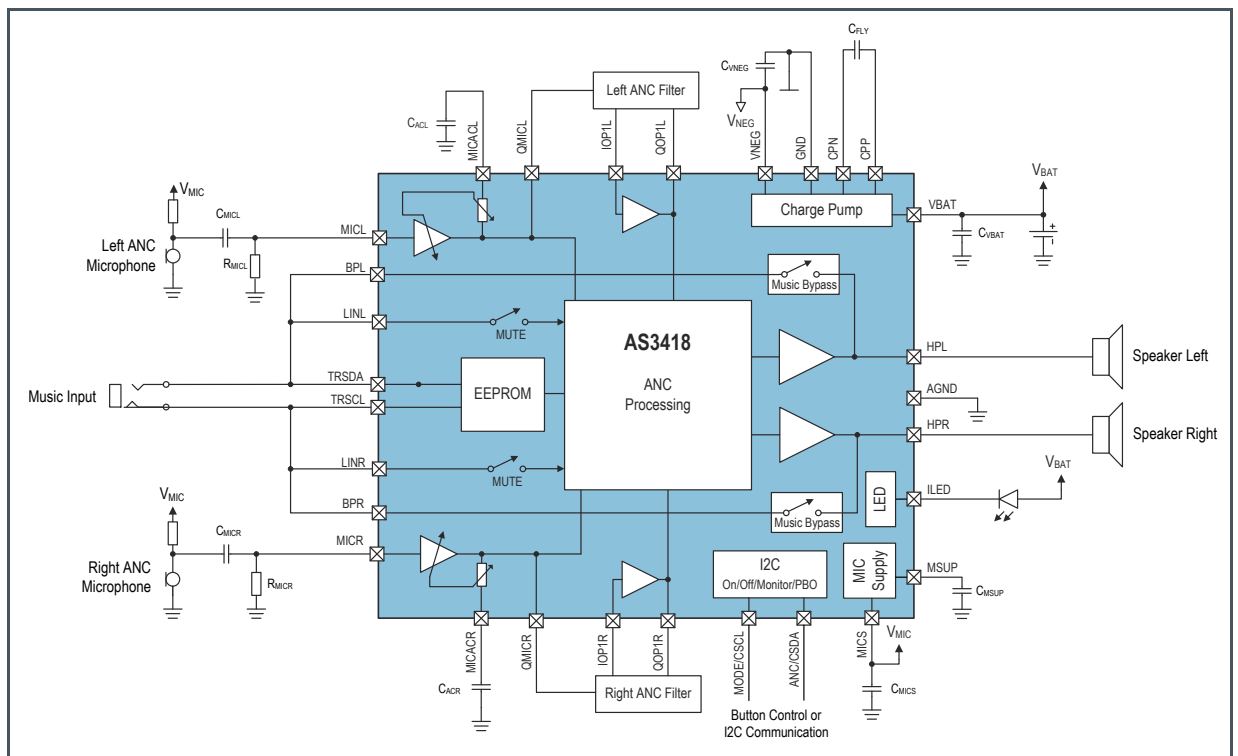

2 Ordering Information

| Ordering Code | Package | Marking | Delivery Form | Delivery Quantity |
|---------------|---------|---------|---------------|-------------------|
| AS3418-EWLT | WL-CSP | AS3418 | Tape & Reel | 6500 pcs/reel |
| AS3418-EWLM | WL-CSP | AS3418 | Tape & Reel | 500 pcs/reel |

3 Pin Assignment

3.1 Pin Diagram

Figure 3 :
Pin Assignment AS3418

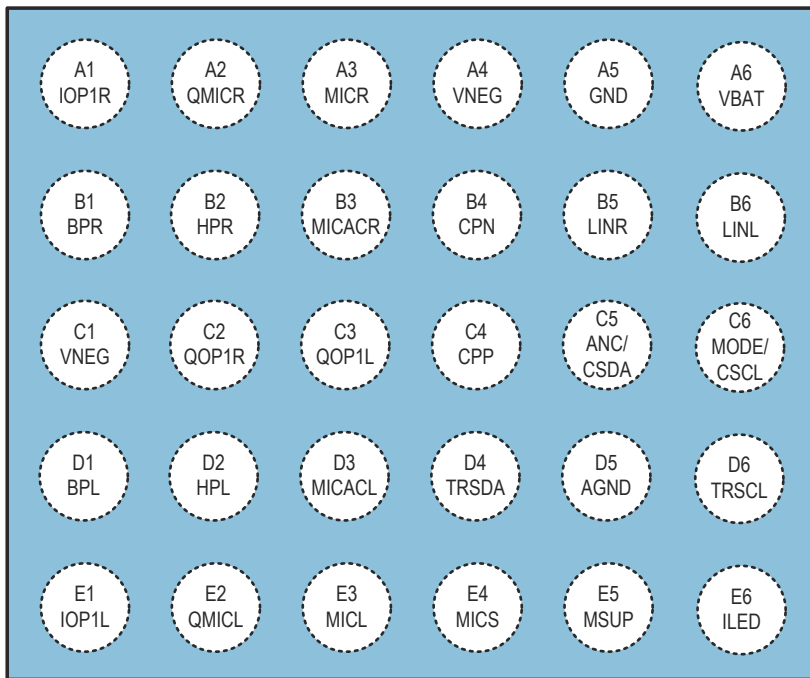

3.2 Pin Description

Figure 4:
Pin Description of AS3418

| Pin Number | Pin Name | Pin Type ⁽¹⁾ | Description |
|------------|----------|-------------------------|--|
| A1 | IOP1R | ANA IN | ANC filter OPAMP1 input - right channel. |
| A2 | QMICR | ANA OUT | ANC microphone preamplifier output - right channel. |
| A3 | MICR | ANA IN | ANC microphone preamplifier input - right channel. |
| A4 | VNEG | SUP OUT | V _{NEG} charge pump output terminal. This output provides the negative amplifier supply voltage for all OPAMPs and the headphone amplifier. |

| Pin Number | Pin Name | Pin Type ⁽¹⁾ | Description |
|------------|---------------|-------------------------|--|
| A5 | GND | ANA IN | V _{NEG} charge pump ground terminal. |
| A6 | VBAT | SUP IN | Positive supply terminal of AS3418. |
| B1 | BPR | ANA IN | Right audio bypass switch input. This pin features a music bypass function for the right audio channel in off mode operation in order to replace and external analog switch. |
| B2 | HPR | ANA OUT | Headphone amplifier output - right channel. |
| B3 | MICACR | ANA OUT | Microphone preamplifier AC coupling ground terminal. This pin requires a typ. 10µF capacitor connected to AGND pin. |
| B4 | CPN | ANA OUT | V _{NEG} charge pump negative terminal for flying capacitor |
| B5 | LINR | ANA IN | Line input - right channel. |
| B6 | LINL | ANA IN | Line input - left channel. |
| C1 | VNEG | SUP OUT | V _{NEG} charge pump output terminal. This output provides the negative amplifier supply voltage for all OPAMPs and the headphone amplifier. |
| C2 | QOP1R | ANA OUT | ANC filter OPAMP1 output - right channel |
| C3 | QOP1L | ANA OUT | ANC filter OPAMP1 output - left channel |
| C4 | CPP | ANA OUT | V _{NEG} charge pump positive terminal for flying capacitor |
| C5 | ANC/ CSDA | DIG IN/OUT | Serial interface data signal line for I ² C interface and alternatively ANC control to enable/disable ANC. |
| C6 | MODE/ CSCL | DIG IN | Serial Interface clock signal line for I ² C interface and alternatively control pin for power up/down and Monitor mode. |
| D1 | BPL | ANA IN | Left audio bypass switch input. This pin features a music bypass function for the left audio channel in off mode operation in order to replace and external analog switch. |
| D2 | HPL | ANA OUT | Headphone amplifier output - left channel. |
| D3 | MICACL | ANA OUT | Microphone preamplifier AC coupling ground terminal. This pin requires a typ. 10µF capacitor connected to AGND pin. |
| D4 | TRSDA | ANA IN | Data input for production trimming. Can be connected to LINL pin to enable production trimming via 3.5mm audio jack. |
| D5 | AGND | ANA IN | Analog reference ground. Do not connect this pin to power or digital ground plane. |
| D6 | TRSCL | ANA IN | Clock input for production trimming. Can be connected to LINR pin to enable production trimming via 3.5mm audio jack. |
| E1 | IOP1L | ANA IN | ANC filter OPAMP1 input - left channel |

| Pin Number | Pin Name | Pin Type ⁽¹⁾ | Description |
|------------|----------|-------------------------|--|
| E2 | QMICL | ANA OUT | ANC microphone preamplifier output - left channel |
| E3 | MICL | ANA IN | ANC microphone preamplifier input - left channel |
| E4 | MICS | SUP OUT | Microphone Supply output to source analog ECM via a bias resistor or MEMs microphones. This pin needs an output blocking capacitor with 4.7µF. |
| E5 | MSUP | SUP IN/OUT | In default configuration a charge pump output that provides the power for the low noise microphone supply LDO. The internal charge pump can also be disabled the MSUP serves as a supply input terminal to source the low noise microphone supply LDO. |
| E6 | ILED | ANA IN | Current sink input for on-indication LED. The Cathode of an LED can be directly connected to this terminal without the need of an external current limitation resistor. |

- (1) Explanation of abbreviations:
- | | |
|------------|-----------------------------------|
| ANA IN | Analog Input |
| ANA OUT | Analog Output |
| DIG IN | Digital Input |
| SUP IN/OUT | Supply input or supply output pad |
| SUP IN | Supply input terminal |
| SUP OUT | Supply output terminal |

4 Absolute Maximum Ratings

Stresses beyond those listed under “Absolute Maximum Ratings” may cause permanent damage to the device. These are stress ratings only. Functional operation of the device at these or any other conditions beyond those indicated under “Operating Conditions” is not implied. Exposure to absolute maximum rating conditions for extended periods may affect device reliability.

Figure 5
Absolute Maximum Ratings of AS3418

| Symbol | Parameter | Min | Max | Unit | Comments |
|--|------------------------------------|------------------------|------------------------|------|--|
| Electrical Parameters | | | | | |
| V _{SUP_MAX} | Supply Voltage to Ground | -0.5 | 2 | V | Applicable for pin VBAT |
| V _{GND_MAX} | Ground Terminals | -0.5 | +0.5 | V | Applicable for pin AGND and GND |
| V _{NEG_MAX} | Negative Terminals | -2.0 | 0.5 | V | Applicable for pin VNEG |
| V _{CP_MAX} | Charge Pump Terminals | V _{NEG} - 0.5 | V _{POS} + 0.5 | V | Applicable for pins CPN and CPP |
| V _{HP_MAX} | Headphone Pins | V _{NEG} - 0.5 | V _{POS} + 0.5 | V | Applicable for pins HPR and HPL |
| V _{ANA_MAX} | Analog Pins | V _{NEG} - 0.5 | V _{POS} + 0.5 | V | Applicable for pins LINL, LINR, MICL/R, HPR, HPL, QMICL/R, IOP1x, QOP1x, CPP, CPN, TRSCL, BPR, TRSDA, BPL, MICACL and MICACR |
| V _{CON_MAX} | Control Pins | V _{NEG} - 0.5 | 5 | V | Applicable for pins ANC/CSDA and MODE/CSCL |
| V _{OTHER_MAX} | Other Pins | V _{NEG} - 0.5 | 5 | V | Applicable for pins MICS and MICFB |
| I _{SCR} | Input Current (latch-up immunity) | | ± 100 | mA | Class II JEDEC JESD78D |
| Electrostatic Discharge | | | | | |
| ESD _{HBM} | Electrostatic Discharge HBM | | ± 2000 | V | Norm: JS-001-2014 |
| Temperature Ranges and Storage Conditions | | | | | |
| T _J | Operating Junction Temperature | | 85 | °C | |
| T _{STRG} | Storage Temperature Range | - 55 | 125 | °C | |
| T _{BODY} | Package Body Temperature | | 260 | °C | IPC/JEDEC J-STD-020 ⁽¹⁾ |
| RH _{NC} | Relative Humidity (non-condensing) | 5 | 85 | % | |
| MSL | Moisture Sensitivity Level | | 1 | | Unlimited floor lifetime |

(1) The reflow peak soldering temperature (body temperature) is specified according to IPC/JEDEC J-STD-020 “Moisture/Reflow Sensitivity Classification for Nonhermetic Solid State Surface Mount Devices.” The lead finish for Pb-free leaded packages is “Matte Tin” (100% Sn)

5 Electrical Characteristics

$V_{BAT} = 1.4V$ to $1.8V$, $T_A = -20^{\circ}C$ to $85^{\circ}C$. Typical values are at $V_{BAT} = 1.6V$, $T_A = 25^{\circ}C$, unless otherwise specified. All limits are guaranteed. The parameters with Min and Max values are guaranteed with production tests or SQC (Statistical Quality Control) methods.

Figure 6:
Electrical Characteristics of AS3418

| Symbol | Parameter | Conditions | Min | Typ | Max | Unit |
|---------------------------------|---|---|------------------------------|------|-----------------------------|-------------|
| T_A | Ambient Temperature Range | | -20 | | 85 | $^{\circ}C$ |
| Supply Voltages | | | | | | |
| GND | Reference Ground | | 0 | | 0 | V |
| V_{BAT} | Battery Supply Voltage | Normal Operation | 1.4 | 1.6 | 1.8 | V |
| V_{NEG} | Charge Pump Voltage | | -1.8 | | -1.2 | V |
| V_{DELTA} | Difference of Ground Supplies GND, AGND | To achieve good performance, the negative supply terminals should be connected to a low impedance ground plane. | -0.1 | | 0.1 | V |
| Other Pins | | | | | | |
| V_{MICS} | Microphone Supply Voltage | Applicable to MICS pin | 0 | | 3.6 | V |
| V_{ANALOG} | Analog Pins | MICACL, MICACR, LINR, LINL, HPR, HPL, QMICL, QMICR, IOP1x, and QOP1x | V_{NEG} | | V_{BAT} | V |
| $V_{CONTROL}$ | Control Pins | Applicable to MODE/C_SCL and ANC/C_SDA pins | 0 | | 3.7 | V |
| V_{CP} | Charge Pump Pins | Applicable to CPN and CPP pins | V_{NEG} | | V_{BAT} | V |
| V_{TRIM} | Application Trim Pins | Applicable to TRSCL and TRSDA pins | $V_{NEG} - 0.3$ or -1.8 | | $V_{BAT} + 0.5$ or 1.8 | V |
| V_{BYP} | Bypass Pins | Applicable to BPR and BPL pins | $V_{NEG} - 0.3$ or -1.8 | | $V_{BAT} + 0.5$ or 1.8 | V |
| V_{MIC} | Microphone Inputs | Applicable to MICL and MICR pins. | V_{NEG} | | V_{BAT} | V |
| Block Power Requirements | | | | | | |
| I_{OFF} | Off mode current | MODE/C_SCL pin low, device switched off | | 1 | 5 | μA |
| I_{SYS} | Reference supply current | $V_{BAT} = 1.8V$; Bias generation, oscillator, POR and V_{NEG} | | 1.45 | | mA |
| | | $V_{BAT} = 1.4V$; Bias generation, oscillator, POR and V_{NEG} | | 1 | | mA |
| I_{MIC} | Microphone gain stage current | $V_{BAT} = 1.8V$; no signal, stereo, High quality mode | | 0.97 | | mA |
| | | $V_{BAT} = 1.8V$; no signal, stereo, ECO mode | | 0.68 | | mA |
| | | $V_{BAT} = 1.4V$; no signal, stereo, High quality mode | | 0.92 | | mA |

| Symbol | Parameter | Conditions | Min | Typ | Max | Unit |
|---|---|---|-----|------|-----|------|
| | | $V_{BAT} = 1.4V$; no signal, stereo, ECO mode | | 0.63 | | mA |
| I_{HP} | Headphone stage current | $V_{BAT} = 1.8V$; no signal, high quality mode | | 2.9 | | mA |
| | | $V_{BAT} = 1.8V$; no signal, ECO mode | | 2.4 | | mA |
| | | $V_{BAT} = 1.4V$; no signal, high quality mode | | 2.78 | | mA |
| | | $V_{BAT} = 1.4V$; no signal, ECO mode | | 2.32 | | mA |
| I_{OP1} | ANC Filter OPAMP current | $V_{BAT} = 1.8V$; OP1L and OP1R enabled, High quality mode | | 1 | | mA |
| | | $V_{BAT} = 1.8V$; OP1L and OP1R enabled, ECO mode | | 0.7 | | mA |
| | | $V_{BAT} = 1.8V$; OP1L and OP1R enabled, High quality mode | | 0.95 | | mA |
| | | $V_{BAT} = 1.8V$; OP1L and OP1R enabled, ECO mode | | 0.65 | | mA |
| I_{MICS} | Microphone low noise LDO supply current | $V_{BAT} = 1.8V$; no load; high quality mode | | 0.69 | | mA |
| | | $V_{BAT} = 1.4V$; no load; high quality mode | | 0.67 | | mA |
| | | $V_{BAT} = 1.8V$; no load; ECO mode | | 0.33 | | mA |
| | | $V_{BAT} = 1.4V$; no load; ECO mode | | 0.32 | | mA |
| I_{MICS_CP} | Microphone supply charge pump current | $V_{BAT} = 1.8V$; no load | | 0.3 | | mA |
| | | $V_{BAT} = 1.4V$; no load | | 0.26 | | mA |
| Typical System Power Consumption | | | | | | |
| P_{FF} | Typical power consumption feed forward application in high quality mode configuration | $V_{BAT} = 1.8V$; OP1L, OP1R enabled, 250 μ A microphone load; all amplifiers in high quality mode | | 15 | | mW |
| | | $V_{BAT} = 1.4V$; OP1L, OP1R enabled, 250 μ A microphone load; all amplifiers in high quality mode | | 10.7 | | mW |
| P_{FF_ECO} | Typical power consumption feed forward application in ECO mode configuration | $V_{BAT} = 1.8V$; OP1L, OP1R enabled, 250 μ A microphone load; all amplifiers in ECO mode | | 12.4 | | mW |
| | | $V_{BAT} = 1.4V$; OP1L, OP1R enabled, 250 μ A microphone load; all amplifiers in ECO mode | | 8.8 | | mW |

6 Functional Description

This section provides a detailed description of the device related components.

6.1 Audio Line Input

The chip features one stereo line input for music playback. In monitor mode the line inputs can also be muted in order to interrupt the music playback and increase speech intelligibility.

Figure 7:
Stereo Line Input

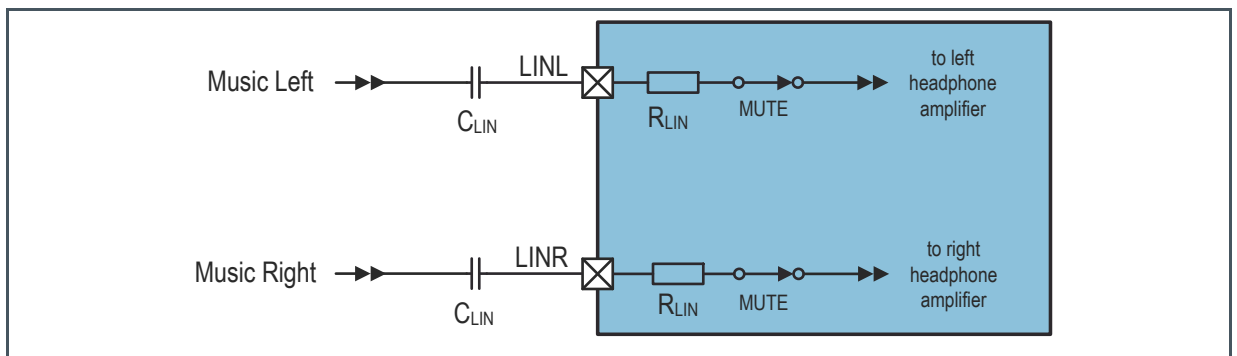

If there is a high pass function desired in an application, to block very low frequencies that could harm the speaker or eliminate little offset voltages, a series capacitor C_{LIN} can support this function. The implementation is shown in Figure 7. The correct capacitor value for the desired cut-off frequency can be calculated with the following formula:

Equation 1:

$$C_{LIN} = \frac{1}{2 * \pi * R_{LIN} * f_{cut-off}}$$

A typical cut-off frequency in an audio application is 20Hz. With an input impedance R_{LIN} of typ. 1k Ω and a desired cut off frequency of 20Hz the input capacitor should be bigger than 8 μ F. Therefore a typical value of 10 μ F is recommended.

6.1.1 Parameter

$V_{BAT}=1.65V$, $T_A= 25^{\circ}C$ unless otherwise specified.

Figure 8:
Parameter of Line Input

| Symbol | Parameter | Conditions | Min | Typ | Max | Unit |
|------------|--------------------|------------|-----|--------------------|-----------|------------|
| V_{LIN} | Input Signal Level | | | V_{BAT}^* 0.9 | V_{BAT} | V_{PEAK} |
| R_{LIN} | Input Impedance | | | 1 | | k Ω |
| A_{MUTE} | Mute Attenuation | | 100 | | | dB |

6.2 Microphone Inputs

The AS3418 offers two low noise microphone inputs with full digital control and a dedicated DC offset cancellation pin for each microphone input. In total each gain stage offers up to 63 gain steps of 0.5dB resulting in a gain range from 0dB to +31dB. The microphone gain is stored digitally during production, in an EEPROM memory on the ANC chip. Besides the standard microphone gain register for left and right channel, the chip features also four additional microphone gain registers for Monitor- and Playback Only operation mode. Thus, in Monitor/Playback Only mode, a completely different gain setting for left and right microphone can be selected to implement voice filter functions in order to amplify the speech band for better intelligibility.

Figure 9:
Stereo Microphone Inputs

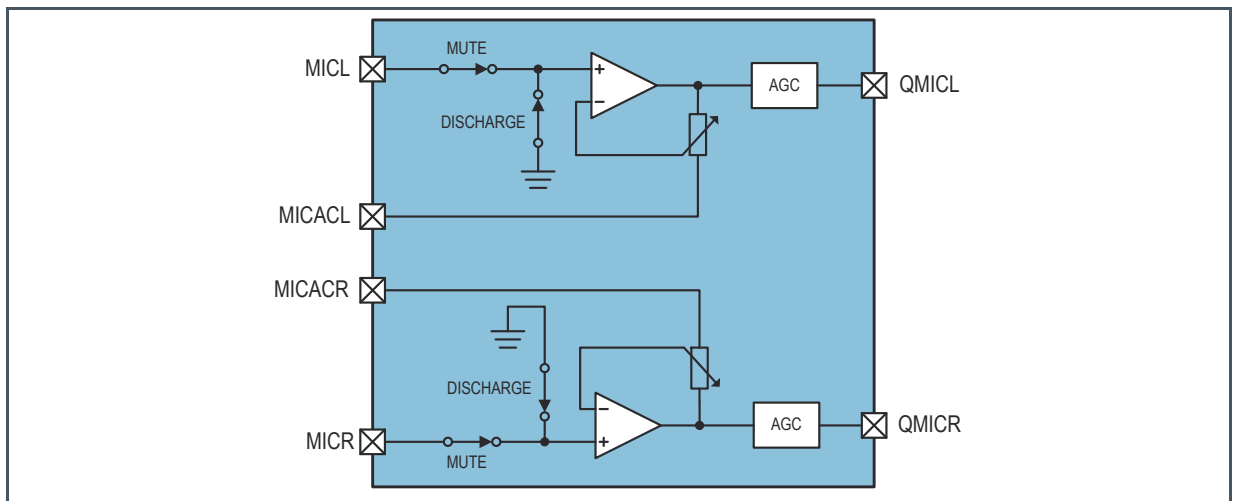

To avoid unwanted start-up pop noise, a soft-start function is implemented for an automatic gain ramping of the device. In case of an overload condition on the microphone input (e.g. high sound pressure level) there is also an automatic gain control (AGC) function available which reduces the gain to a moderate level. For some designs it might be useful to switch off this feature. Especially in feedback systems infrasound can cause an overload condition of the microphone preamplifier that results in low frequency noise which can be avoided by disabling the AGC.

6.2.1 Input Capacitor Selection

The microphone preamplifier needs a bias resistor (R_{BIAS}) per channel as well as DC blocking capacitors (C_{MIC}). The capacitors C_{AC} are DC blocking capacitors to avoid DC amplification of the non-inverting microphone preamplifier. This capacitor has an influence on the frequency response because the internal feedback resistors create a high pass filter. The typical application circuit is shown in Figure 10 with all necessary components.

Figure 10:
Microphone Capacitor Selection Circuit

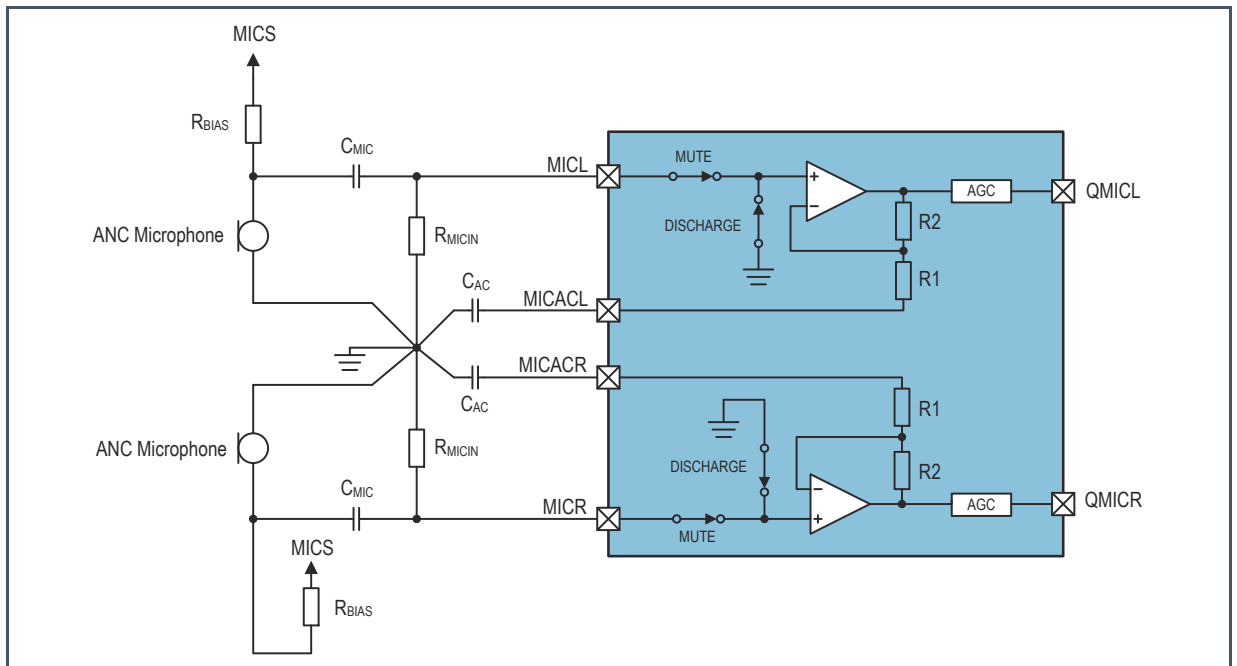

The corner frequency of this high pass filter is defined with the capacitor C_{AC} and the gain of the headphone amplifier. Figure 11 shows an overview of typical cut-off frequencies with different microphone gain settings.

Figure 11:
Microphone Cut-Off Frequency Overview

| Microphone Gain | R_1 | R_2 | $f_{cut-off}$ |
|-----------------|----------------|----------------|---------------|
| 0dB | 22.2k Ω | 0 Ω | 1.7Hz |
| 3dB | 15716 Ω | 6484 Ω | 1.9Hz |
| 6dB | 11126 Ω | 11074 Ω | 2.2Hz |
| 9dB | 7877 Ω | 14323 Ω | 2.7Hz |
| 12dB | 5576 Ω | 16623 Ω | 3.5Hz |
| 15dB | 3948 Ω | 18252 Ω | 4.5Hz |

| Microphone Gain | R ₁ | R ₂ | f _{cut-off} |
|-----------------|----------------|----------------|----------------------|
| 18dB | 2795Ω | 19405Ω | 6.1Hz |
| 21dB | 1979Ω | 20221Ω | 8.4Hz |
| 24dB | 1400Ω | 20800Ω | 11.5Hz |
| 27dB | 992Ω | 21208Ω | 16.3Hz |
| 30dB | 702Ω | 21498Ω | 22.7Hz |

It is important when doing the ANC filter simulations to include all microphone filter components to incorporate the **gain and phase influence** of these components. In the cut-off frequency overview, capacitor C_{AC} was defined as 10μF which results in a rather low cut-off frequency for best ANC filter design. If a different capacitor value is desired in the application, the following formula defines the transfer function of the high pass circuit of the microphone preamplifier:

Equation 2:

$$|A| = \frac{\sqrt{4 * C_{AC}^2 * f^2 * (R_1 + R_2)^2 * \pi^2 + 1}}{\sqrt{4 * C_{AC}^2 * f^2 * R_1^2 * \pi^2 + 1}}$$

The simplified transfer function does not include the high pass filter defined by CMIC and RMICIN. With the recommended values of 2.2μF for CMIC and 22kΩ for RMICIN this filter can be neglected because of the very low cut-off frequency of 1.5Hz. The cut-off frequency for this filter can be calculated with the following formula:

Equation 3:

$$f_{cut-off} = \frac{1}{2 * \pi * R_{MICIN} * C_{MIC}}$$

The simulated frequency response for the microphone preamplifier with the recommended component values is shown in Figure 12.

Figure 12 :
Simulated Microphone Frequency Response

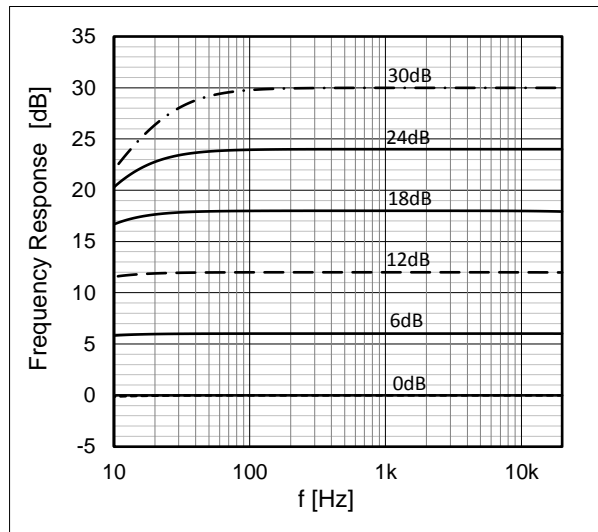

In applications with PCB space limitations it is also possible to remove the capacitors C_{AC} and connect MICACL and MICACR pins directly to AGND. In this configuration AC coupling of the QMICR and QMICL signals is recommended.

6.2.2 Parameter

$V_{BAT}=1.8V$, $T_A= 25^{\circ}C$, $C_{AC}=10\mu F$, $C_{MIC}=4.7\mu F$ and $R_{MICIN}=2.2k\Omega$ unless otherwise specified.

Figure 13:
Microphone Parameter

| Symbol | Parameter | Conditions | Min | Typ | Max | Unit |
|----------------|------------------------------------|--|-----|------|-----|-------------------|
| V_{MICIN_0} | Typical maximum Input Signal Level | Preamplifier gain=0dB, THD < 0.1% | | 1050 | | mV _{RMS} |
| V_{MICIN_0} | | Preamplifier gain=20dB, THD < 0.1% | | 110 | | mV _{RMS} |
| SNR | Signal to Noise Ratio | 0dB gain, High quality mode, AGC disabled | | 119 | | dB |
| | | 10dB gain, High quality mode, AGC disabled | | 109 | | dB |
| | | 20dB gain, High quality mode, AGC disabled | | 106 | | dB |
| | | 0dB gain, ECO mode, AGC disabled | | 117 | | dB |
| | | 10dB gain, ECO mode, AGC disabled | | 108 | | dB |

| Symbol | Parameter | Conditions | Min | Typ | Max | Unit |
|---|-------------------------------|---|---------------------------|---|-----|---------------|
| | | 20dB gain, ECO mode, AGC disabled | | 105 | | dB |
| $V_{\text{NOISE-A}}$ | A-weighted output noise floor | 0dB gain, 20Hz – 20kHz bandwidth, high quality | | 1.3 | | μV |
| | | 10dB gain, 20Hz – 20kHz bandwidth, high quality | | 4.5 | | μV |
| | | 20dB gain, 20Hz – 20kHz bandwidth, high quality | | 13.7 | | μV |
| | | 0dB gain, 20Hz – 20kHz bandwidth, ECO mode | | 1.4 | | μV |
| | | 10dB gain, 20Hz – 20kHz bandwidth, ECO mode | | 5 | | μV |
| | | 20dB gain, 20Hz – 20kHz bandwidth, ECO mode | | 15.7 | | μV |
| | | I_{MIC} | Block Current Consumption | $V_{\text{BAT}} = 1.8\text{V}$; no signal, stereo, normal mode | | 1 |
| $V_{\text{BAT}} = 1.8\text{V}$; no signal, stereo, ECO mode | | | | 0.7 | | mA |
| $V_{\text{BAT}} = 1.4\text{V}$; no signal, stereo, normal mode | | | | 0.9 | | mA |
| $V_{\text{BAT}} = 1.4\text{V}$; no signal, stereo, ECO mode | | | | 0.6 | | mA |
| A_{MIC} | Programmable Gain | | 0 | | 31 | dB |
| | Gain Step Size | | | 0.5 | | dB |
| | Gain Step Precision | | | | 0.2 | dB |

Figure 14 :
Microphone Frequency Response (MICACx grounded; $C_{MIC}=10\mu F$)

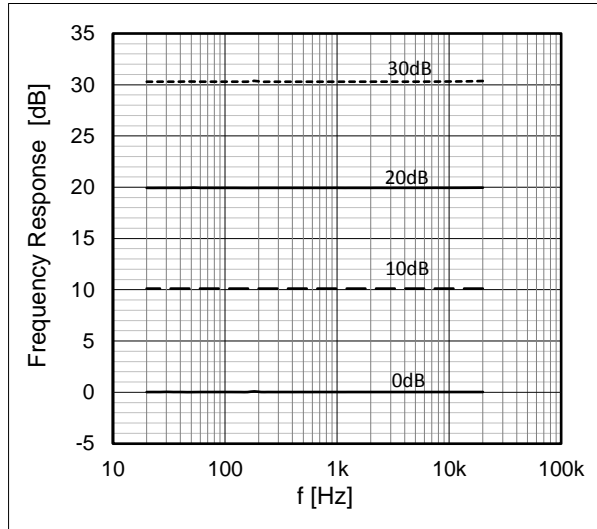

Figure 15:
Microphone THD+N vs. V_{input} High Quality Mode (A-weighted)

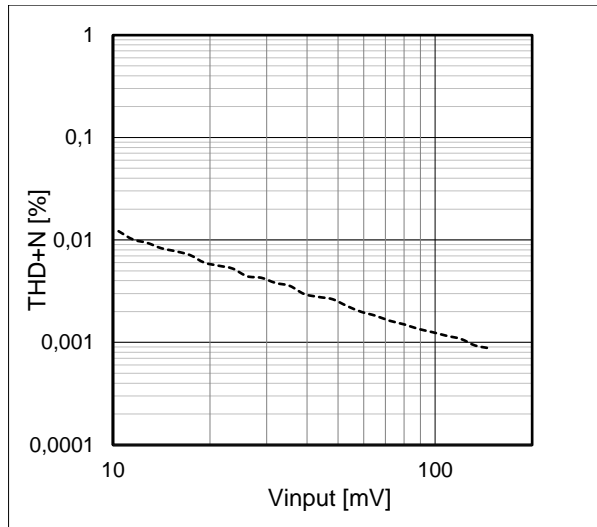
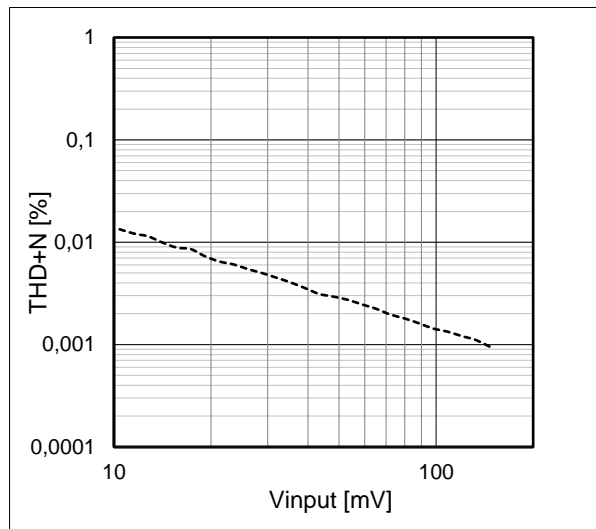

Figure 16:
Microphone THD+N vs. V_{input} ECO Mode (A-weighted)



6.3 Microphone Supply

The AS3418 features an integrated microphone supply voltage regulator and a charge pump to source the microphone LDO even with a 1.4V chip supply voltage in order to increase the sensitivity of the microphone. The microphone supply charge pump is in default configuration enabled and can be controlled in ANC and Monitor operation mode with register **ANCMON_MICS_CP_ON** bit. For PBO operation mode there is a dedicated control bit **PBO_MICS_CP_ON**.

The output of the charge pump is directly connected to an internal microphone supply ultra-low noise voltage regulator. This low dropout (LDO) regulator is in default configuration enabled and can be controlled with **ANCMON_MICS_ON** bit. The default output voltage of the regulator is 2.9V. If there is a lower output voltage desired in an application the voltage level can be changed via register **MICS_V_SEL** register.

If the AS3418 is connected to a 1.5V battery the input voltage will of course drop during operation because the battery is discharging during operation. In order to make sure the microphone supply LDO has enough headroom to regulate properly the device features an automatic output voltage adjustment feature. This function makes sure the voltage regulator has enough headroom and adjusts the output voltage of the LDO accordingly.

Figure 17:
Microphone Supply

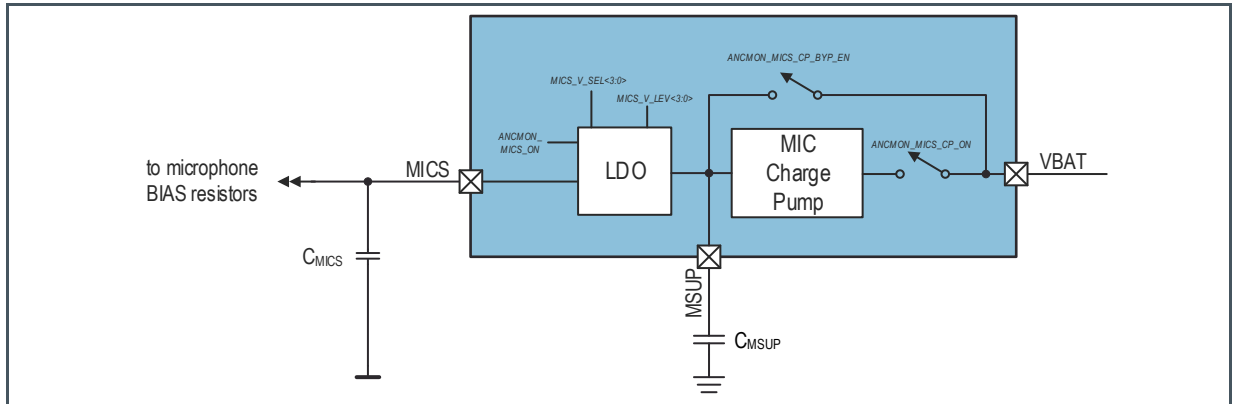

The microphone supply charge pump is also used to switch off the integrated music bypass switch of the AS3418 in active mode. Therefore, during normal operation the microphone supply must not be switched off if the BPL and BPR pins are in use.

6.3.1 Parameter

$V_{BAT}=1.8V$, $T_A=25^{\circ}C$, $C_{MSUP} = 4.7\mu F$ and $C_{MICS} = 4.7\mu F$ unless otherwise specified.

Figure 18:
Microphone Supply Parameter

| Symbol | Parameter | Conditions | Min | Typ | Max | Unit |
|---------------|---|--|-----|------|-----|---------|
| V_{MICS} | Microphone supply LDO output voltage | $V_{BAT}=1.8V$; no load; charge pump activated | | 2.9 | | V |
| | | $V_{BAT}=1.4V$; no load; charge pump activated | | 2.5 | | V |
| V_{MSUP} | Microphone supply charge pump output voltage | $V_{BAT}=1.8V$; no load; MICS voltage regulator off | | 3.15 | | V |
| | | $V_{BAT}=1.4V$; no load; MICS voltage regulator off | | 2.7 | | V |
| $V_{Noise-A}$ | Microphone Supply Noise at MICS output | High quality mode enabled; 1mA load; A-weighted | | 1.7 | | μV |
| | | High quality mode disabled; 1mA load; A-weighted | | 2.2 | | μV |
| I_{MICS} | Current consumption low noise voltage regulator | $V_{BAT} = 1.8V$; no load; HIQ_EN_MICS_LDO = 1 | | 0.69 | | mA |
| | | $V_{BAT} = 1.4V$; no load; HIQ_EN_MICS_LDO = 1 | | 0.67 | | mA |

| Symbol | Parameter | Conditions | Min | Typ | Max | Unit |
|----------------|---|---|-----|------|-----|------|
| | | $V_{BAT} = 1.8V$; no load; HIQ_EN_MICS_LDO = 0 | | 0.33 | | mA |
| | | $V_{BAT} = 1.4V$; no load; HIQ_EN_MICS_LDO = 0 | | 0.32 | | mA |
| I_{MICS_CP} | Current consumption microphone supply charge pump | $V_{BAT} = 1.8V$; MICS voltage regulator off; no load | | 0.3 | | mA |
| | | $V_{BAT} = 1.8V$; MICS voltage regulator off; 1mA load | | 3.5 | | mA |
| | | $V_{BAT} = 1.4V$; MICS voltage regulator off; no load | | 0.26 | | mA |
| | | $V_{BAT} = 1.4V$; MICS voltage regulator off; 1mA load | | 3.33 | | mA |
| I_{OUT} | Output current | Charge pump activated | | 2 | | mA |

Figure 19:
Microphone Supply Load Characteristic

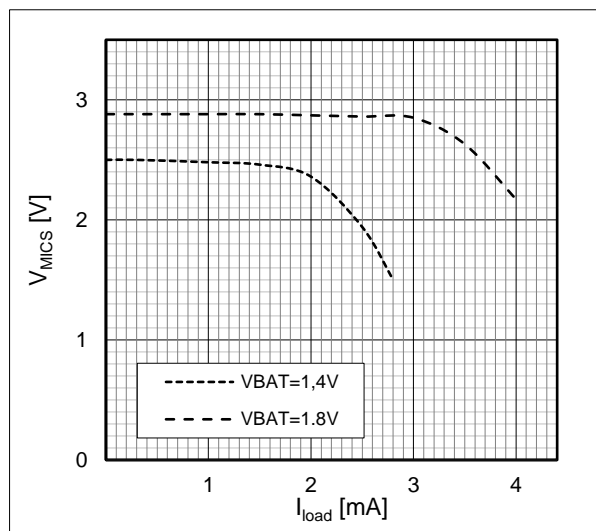

6.4 Headphone Amplifier

The headphone amplifier is a true ground output using V_{NEG} as negative supply. It is designed to feature an output power of $2 \times 34mW @ 32\Omega$ load. For higher output requirements, the headphone amplifier is also capable of operating in bridged mode. In this mode the left output is carrying the inverted signal of the right output shown in Figure 21. With a V_{BAT} voltage of 1.8V, a maximum output power of 100mW can be achieved. This is necessary for over- and on ear headsets with higher output power requirements. The amplifier itself features various input sources. The line input signal is directly connected to the headphone amplifier. The input multiplexer supports three different input signals

which can be configured according in the **ANC_HPH_MUX**, **MON_HPH_MUX** and **PBO_HPH_MUX** registers independently for each operation mode. The “Open” setting is being used to disable the active noise cancelling function.

Figure 20:
Headphone Amplifier Single Ended

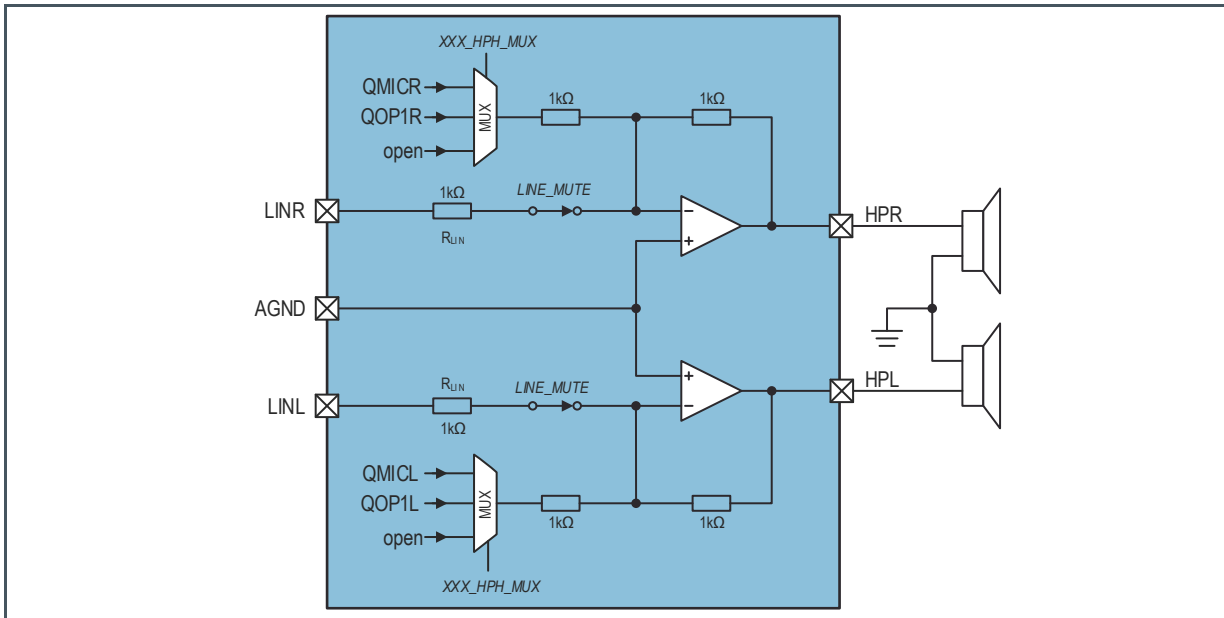
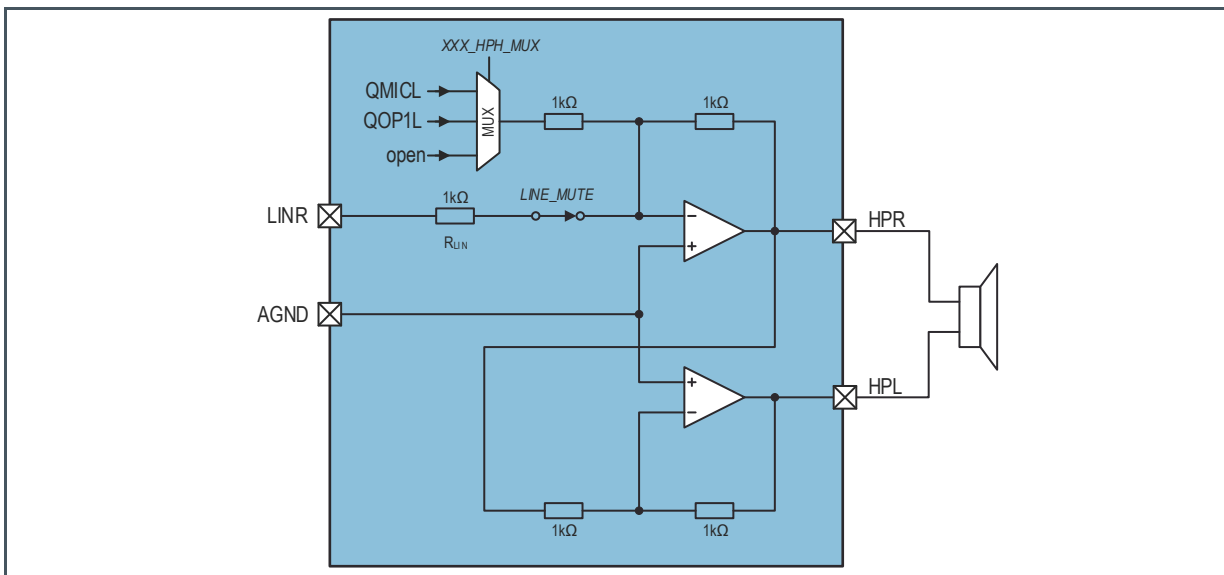

Figure 21:
Headphone Amplifier Differential



6.4.1 Parameter

$V_{BAT} = 1.8V$, $T_A = 25^{\circ}C$, unless otherwise specified.

Figure 22:
Microphone Supply Parameter

| Symbol | Parameter | Conditions | Min | Typ | Max | Unit |
|---------------------|--|---|-----|-------|-----|----------|
| R _{L_HP} | Load Impedance | Stereo Operation Mode | 16 | 32 | | Ω |
| | | Mono Operation Mode | 32 | | | Ω |
| C _{L_HP} | Load Capacitance | Per channel | | | 100 | pF |
| P _{HP} | Nominal Output Power Stereo Mode | $V_{BAT} = 1.8V$; 32 Ω load; THD<0.1% | | 35 | | mW |
| | | $V_{BAT} = 1.4V$; 32 Ω load; THD<0.1% | | 20 | | mW |
| | | $V_{BAT} = 1.8V$; 16 Ω load; THD<0.1% | | 55 | | mW |
| | | $V_{BAT} = 1.4V$; 16 Ω load; THD<0.1% | | 30 | | mW |
| P _{BRIDGE} | Nominal Output Power Differential Mode | $V_{BAT} = 1.8V$; 32 Ω load; THD<0.1% | | 130 | | mW |
| | | $V_{BAT} = 1.4V$; 32 Ω load; THD<0.1% | | 75 | | mW |
| I _{HPH} | Supply Current | $V_{BAT} = 1.8V$; no input signal, normal mode | | 2.9 | | mA |
| | | $V_{BAT} = 1.8V$; no input signal, ECO mode | | 2.4 | | mA |
| | | $V_{BAT} = 1.4V$; no input signal, normal mode | | 2.8 | | mA |
| | | $V_{BAT} = 1.4V$; no signal, ECO mode | | 2.3 | | mA |
| P _{SRRHP} | Power Supply Rejection Ratio | 1kHz | | 100 | | dB |
| SNR | Signal to Noise Ratio | High Quality Mode, Line Input -> HPH stereo in phase test signal; 32 Ω load; $V_{BAT} = 1.8V$; A-weighted | | 117 | | dB |
| | | High Quality Mode, Line Input -> HPH stereo out of phase test signal; 32 Ω load; $V_{BAT} = 1.8V$; A-weighted | | 117.5 | | dB |
| | | ECO Mode, Line Input -> HPH stereo in phase test signal; 32 Ω load; $V_{BAT} = 1.8V$; A-weighted | | 114 | | dB |

| Symbol | Parameter | Conditions | Min | Typ | Max | Unit |
|----------------------|----------------------------------|--|-----|-------|-----|------|
| | | ECO Mode, Line Input -> HPH stereo out of phase test signal; 32Ω load; V _{BAT} = 1.8V; A- weighted | | 114.5 | | dB |
| A _{CHANNEL} | Channel Separation | 32Ω load | | 93 | | dB |
| V _{NOISE-A} | A-Weighted Output Noise Floor | High Quality Mode; 32Ω load; HP_MUX = nc; LINx connected to ground | | 1.5 | | μV |
| | | ECO Mode; 32Ω load; HP_MUX = nc; LINx connected to ground | | 2.1 | | μV |

Figure 23:
Headphone THD+N vs. Output Power 32Ω
Stereo – High Quality Mode

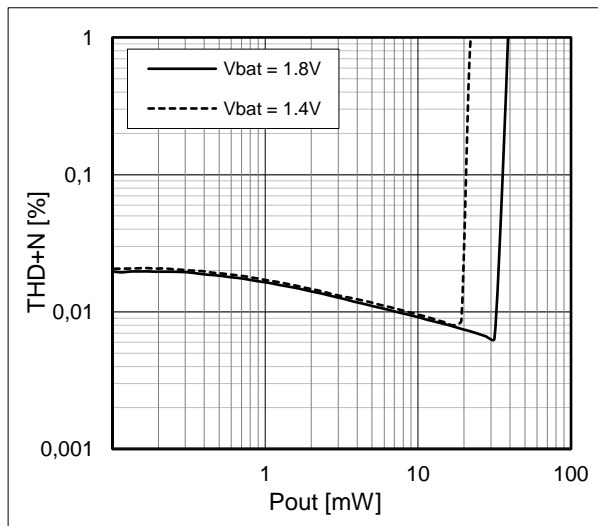

Figure 24:
Headphone THD+N vs. Output Power 32Ω
Stereo – ECO Mode

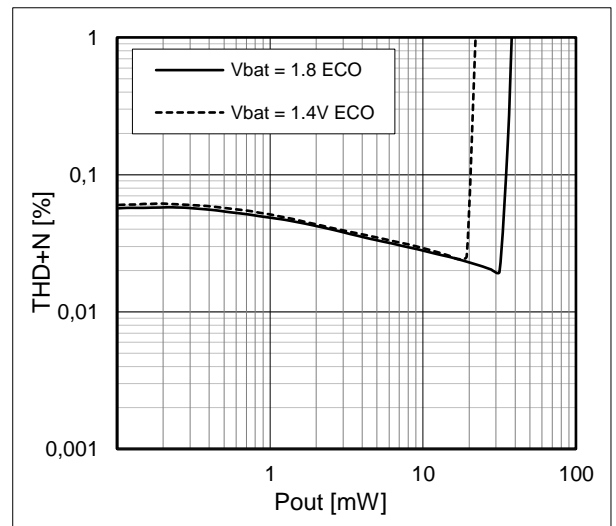

Figure 25:
Headphone THD+N vs. Output Power 16Ω
Stereo – High Quality Mode

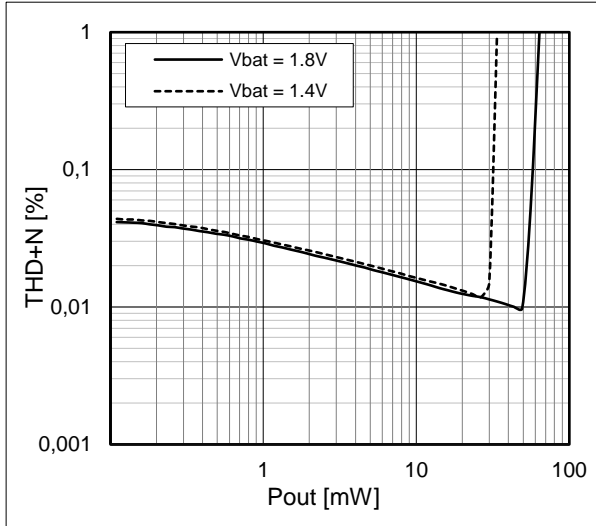

Figure 26:
Headphone THD+N vs. Output Power 16Ω
Stereo – ECO Mode

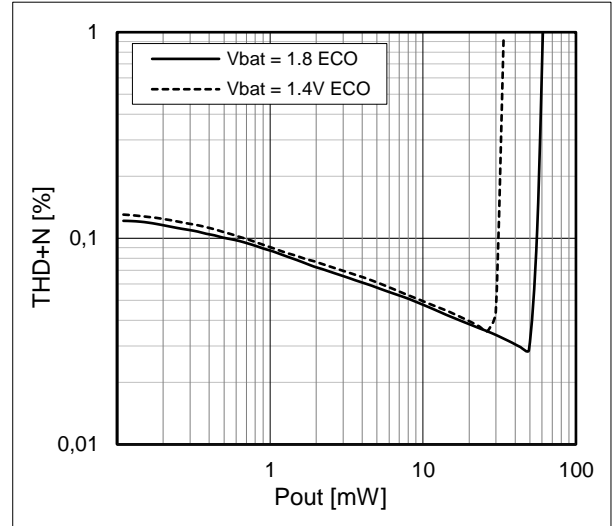

Figure 27:
Headphone THD+N vs. Output Power 32Ω
MONO – High Quality Mode (1.8/1.4V)

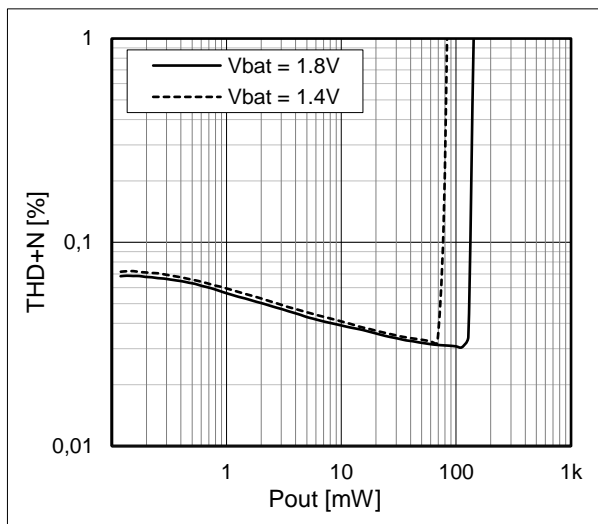
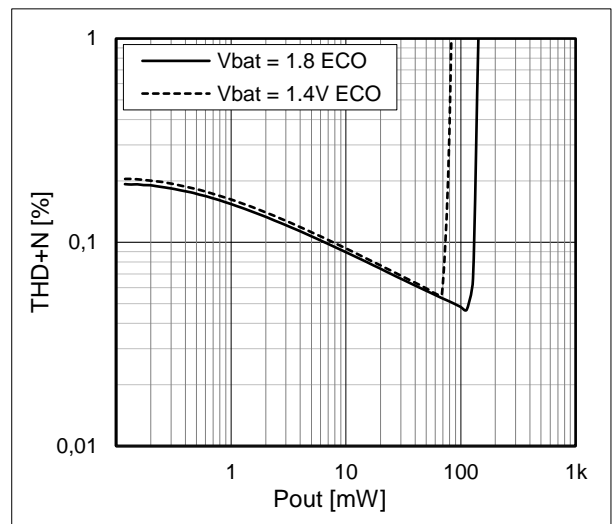

Figure 28:
Headphone THD+N vs. Output Power 32Ω
MONO –ECO Mode (1.8/1.4V)



6.5 Music Bypass Switch

If the AS3418 is switched off, the device features a unique feature, which are integrated music bypass switches. These switches can be used to replace a mechanical switch to bypass the music signal in

off mode or if the headset runs out of battery. Figure 29 shows the basic music playback path of the AS3418 with a full battery. In this mode the line input signal is feed to the headphone amplifier. The integrated bypass switches are automatically disabled in this operation mode.

Figure 29:
Bypass Mode Inactive

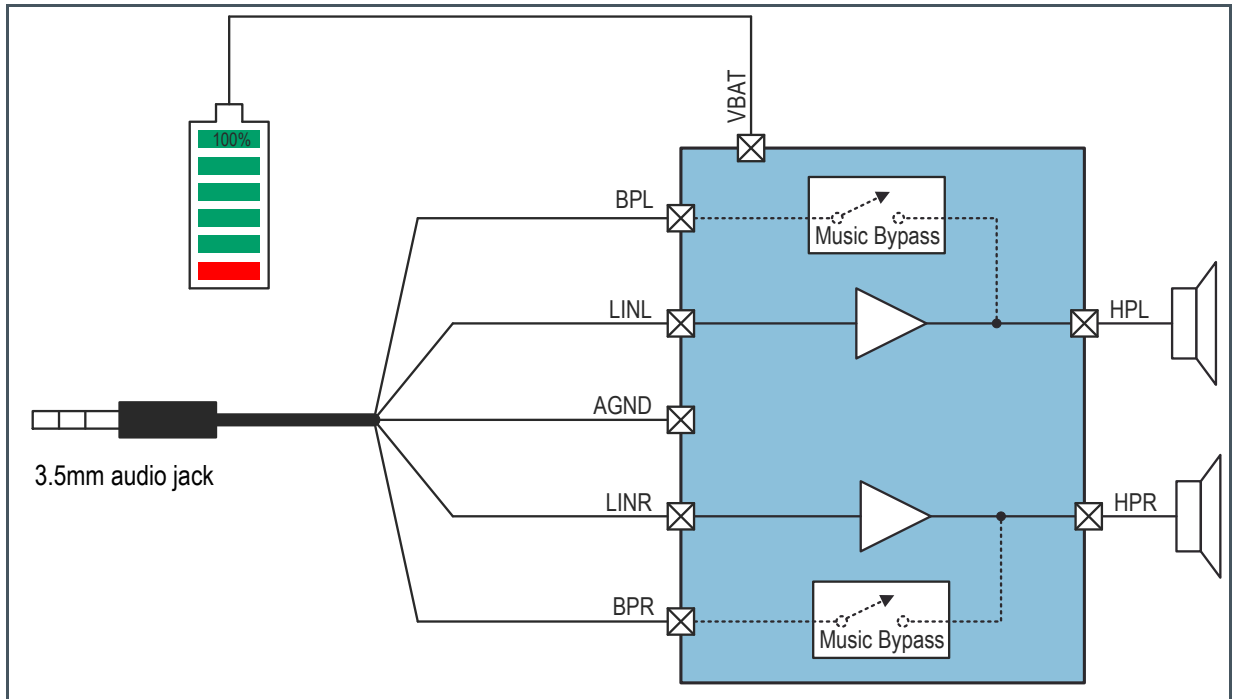
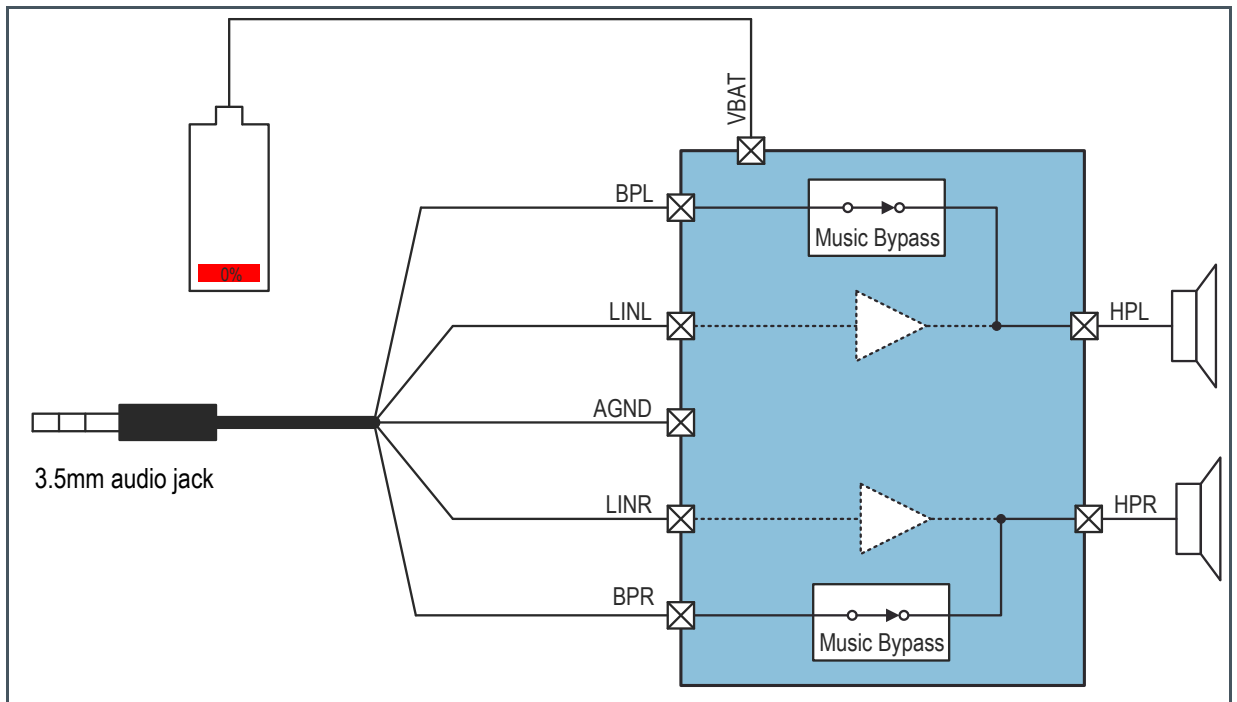

Figure 30 shows the AS3418 in off mode with an empty battery. This is basically the same use case as no battery at all. In this mode the internal bypass switch becomes active. The headphone amplifier is not powered because the headset has run out of battery and the bypass switch becomes active. Thus the music signal coming from the 3.5mm audio jack is routed through the ANC chip, without any power source connected to the device, to the speakers. The integrated bypass switch works even without any battery connected to the device. It helps to reduce BOM costs and PCB area. Furthermore it facilitates new industrial designs to ANC solutions.

Figure 30:
Bypass Mode Active



6.5.1 Parameter

$V_{BAT} = 0V$, $T_A = 25^\circ C$, unless otherwise specified.

Figure 31:
Bypass Switch Parameter

| Symbol | Parameter | Conditions | Min | Typ | Max | Unit |
|--------------|---------------------------|-------------------------------------|-----|-----|-----|----------|
| R_{SWITCH} | Switch resistance | Power down | | 1.2 | | Ω |
| THD | Total Harmonic Distortion | 0dBV input signal, 32 Ω load | | -85 | | dB |
| | | 0dBV input signal, 16 Ω load | | -79 | | dB |

Figure 32 :
Bypass THD+N vs. Output Power 32Ω Load

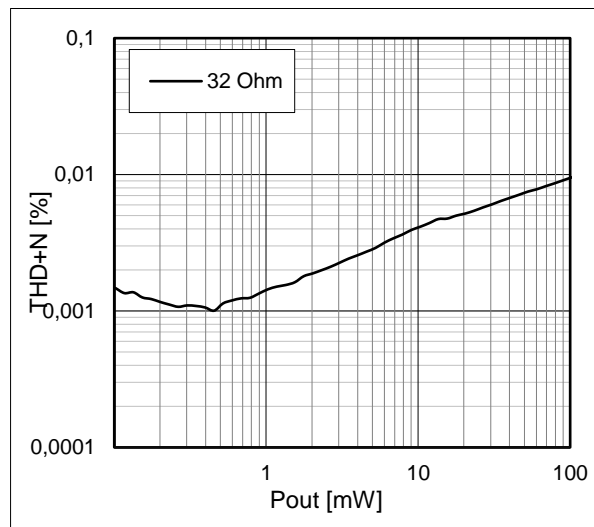

6.6 Operational Amplifier

The AS3418 offers one general purpose operational amplifier for feed-forward ANC. The amplifier is used to develop the gain- and phase compensation filter for the ANC signal path.

Figure 33:
Operational Amplifier

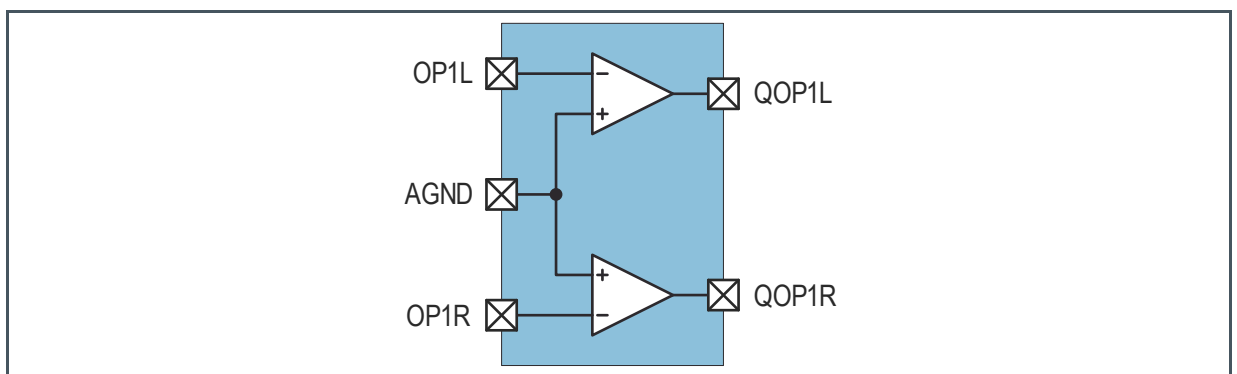

6.6.1 Parameter

$V_{BAT} = 1.8V$, $T_A = 25^{\circ}C$, $R_{input} = R_{FB} = 1k\Omega$ unless otherwise specified.

Figure 34:
Operational Amplifier Parameter

| Symbol | Parameter | Conditions | Min | Typ | Max | Unit |
|---------------|--|---|-----|---------------------|-----------|------------|
| V_{IN} | Input Signal Level | Gain=0dB | | $0.9 \cdot V_{BAT}$ | V_{BAT} | V_{PEAK} |
| SNR | Signal to Noise Ratio | 10k Ω load, Gain = 0dB ⁽¹⁾ , $V_{BAT}=1.8V$, High Quality Mode | | 114.5 | | dB |
| | | 10k Ω load, Gain = 0dB ⁽¹⁾ , $V_{BAT}=1.4V$ High Quality Mode | | 111.4 | | dB |
| | | 10k Ω load, Gain = 0dB ⁽¹⁾ , $V_{BAT}=1.8V$, ECO Mode | | 113.3 | | dB |
| | | 10k Ω load, Gain = 0dB ⁽¹⁾ , $V_{BAT}=1.4V$, ECO Mode | | 110 | | dB |
| I_{OP1} | Block Current Consumption | $V_{BAT} = 1.8V$; OP1L and OP1R enabled; normal mode | | 1 | | mA |
| | | $V_{BAT} = 1.8V$; OP1L and OP1R enabled; ECO mode | | 0.7 | | mA |
| | | $V_{BAT} = 1.4V$; OP1L and OP1R enabled; normal mode | | 0.95 | | mA |
| | | $V_{BAT} = 1.4V$; OP1L and OP1R enabled; ECO mode | | 0.65 | | mA |
| $V_{NOISE-A}$ | Input Referred Noise Floor A- Weighted | High Quality Mode | | 2.2 | | μV |
| | | ECO Mode | | 2.6 | | μV |
| V_{OFFSET} | DC offset voltage | Gain=0dB | | | 500 | μV |
| C_L | Load Capacitance | | | | 100 | pF |
| R_L | Load Impedance | | 1 | | | k Ω |
| A_{LOOP} | Open Loop Gain | 100MHz | | 120 | | dB |

(1) SNR figure measured with 20dB gain to minimize audio analyzer noise floor

Figure 35 :
Operational Amplifier Frequency Response

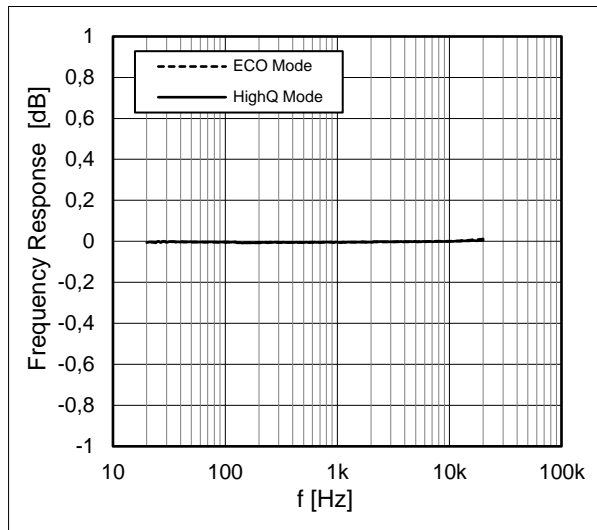
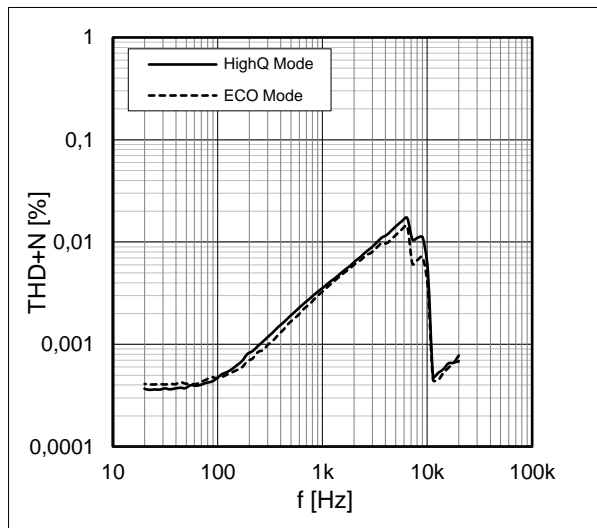

Figure 36 :
OPAMP THD+N vs. Frequency



6.7 System

This chapter describes the power up and power down conditions of AS3418. Furthermore the Start-up sequence of the device is also described in more detail.

Figure 37:
Power Up Conditions

| # | Source | Description |
|---|----------------------------------|---|
| 1 | MODE/CSCL pin | <p>Depending on the operation mode the power up/down pin MODE/CSCL pin behaves differently:</p> <p>Slider Mode: Mode pin has to be driven high turn on the device. Since the timing can be programmed the value depends also on POWER_UP_BUT_TIME register setting. With default configuration of POWER_UP_BUT_TIME register typ. button press time is ~16ms.</p> <p>Full Slider Mode: Mode pin has to be driven high turn on the device. Since the timing can be programmed the value depends also on POWER_UP_BUT_TIME register setting. With default configuration of POWER_UP_BUT_TIME register typ. button press time is ~16ms.</p> <p>Push Button Mode: Mode pin has to be driven high turn on the device. Since the timing can be programmed the value depends also on POWER_UP_BUT_TIME register setting. With default configuration of POWER_UP_BUT_TIME register typ. button press time is ~16ms.</p> |
| 2 | I ² C start condition | In I ² C mode, an I ² C start condition turns on the device. For this startup function I2C_MODE bit must be set in the EEPROM register. |

The chip automatically powers down if one of the following conditions arises:

Figure 38:
Power Down Conditions

| # | Source | Description |
|---|-------------------------------------|---|
| 1 | MODE/CSCL pin | <p>Depending on the operation mode the power MODE/CSCL pin behaves differently:</p> <p>Slider Mode: Mode pin has to be driven low for min. 10ms to turn off the device</p> <p>Full Slider Mode: Mode pin has to be driven low for min. 10ms to turn off the device</p> <p>Push Button Mode: Mode pin has to be high for the time defined in PWR_DOWN_BUT_TIME register to turn off the device.</p> |
| 2 | I ² C power down command | Power down by serial interface is initiated by clearing the PWR_HOLD bit. (Please mind that the I2C_MODE bit has to be set before clearing the PWR_HOLD bit to enable the I ² C power down mode) |
| 3 | V _{NEG} over current | Power down if V _{NEG} is higher than the V _{NEG} off-threshold. |

6.7.1 Start-Up Sequence

The AS3418 has a defined startup sequence. Once the AS3418 MODE pin is pulled high, the device initiates the automatic startup sequence shown in Figure 39 or Figure 40 depending on the operation

mode. In case the **I2C_MODE** bit is set the device behaves differently during startup compared to normal operation with external slide switch or push button.

Figure 39:
Normal Start-Up Sequence

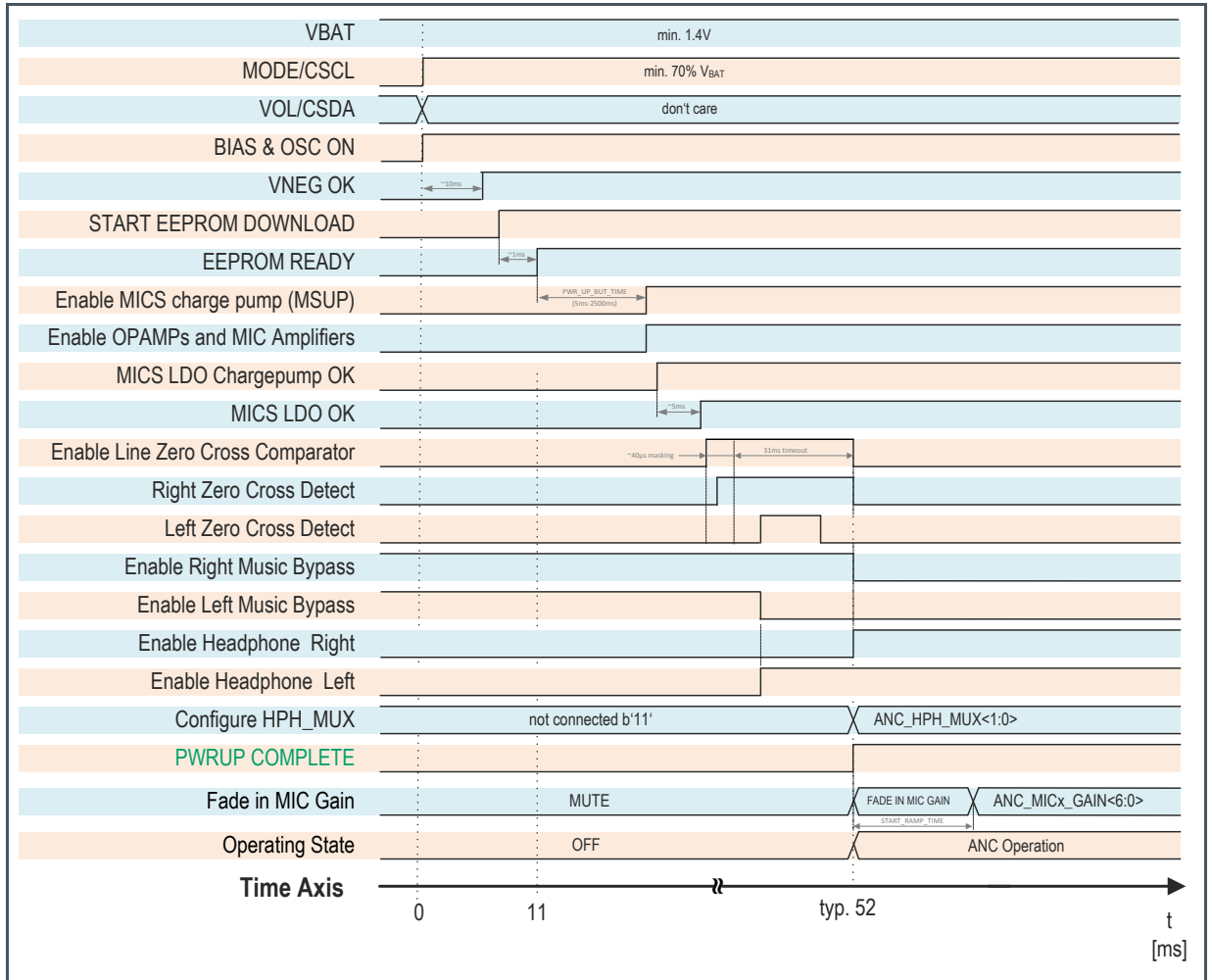
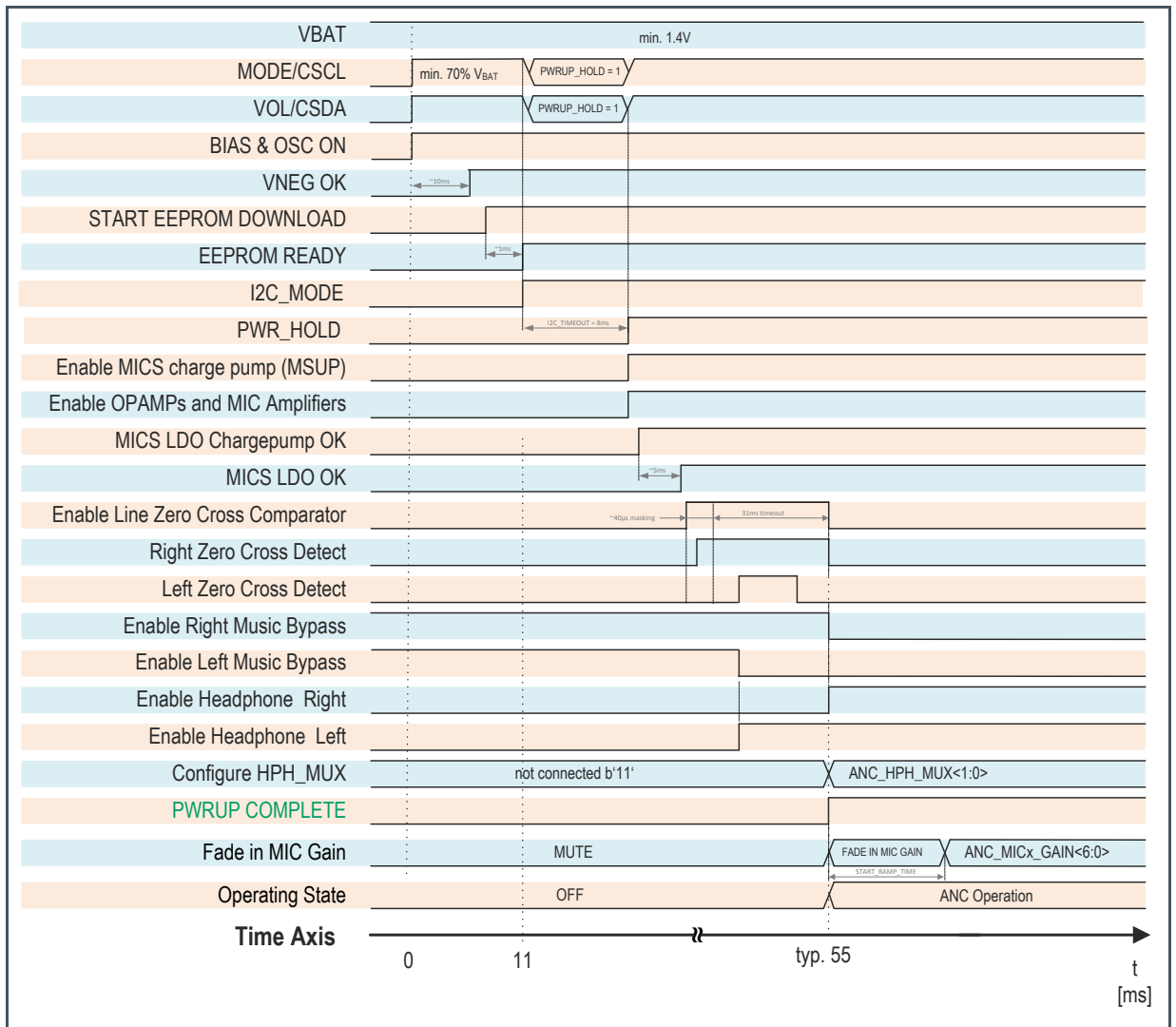

Figure 40:
I²C Start-Up Sequence



6.8 Operation Modes

If the AS3418 is in stand-alone mode (no I²C control), the device can work in different operation modes. An overview of the different operation modes is shown in Figure 41.

Figure 41:
Operation Modes

| MODE | Description |
|------|---|
| OFF | Chip is turned off. |
| ANC | Chip is turned on and active noise cancellation is enabled. |

| MODE | Description |
|---------|--|
| MONITOR | In Monitor Mode, a different (normally higher) microphone preamplifier gain can be configured to get an amplification of the ambient noise. To get rid of the low pass filtering needed for the noise cancellation, the headphone input multiplexer can be set to a different (normally to MIC) source to increase speech intelligibility. In addition, the Line Input signal can be muted for further improved intelligibility. If the device is operated in I ² C mode, it is also possible to enter the monitor mode by setting the MON_MODE_EN bit in register 0x03. |
| PBO | The Playback Only mode is a special mode that disables the noise cancelling function and just keeps e.g. line input amplifier or headphone amplifier active. Certainly this operation mode can also be used as an alternative Monitor or ANC mode with different gain settings. |

With the AS3418 design engineers have different options to enter the described operation modes shown in Figure 41. In addition to the different user interface modes described in the following three chapters, it is also important to configure the device accordingly. Figure 42 shows the required register configuration settings to enable the different AS3418 control modes.

Figure 42:
User Interface Control Modes

| MODE | Register UI_MODE<1:0> | |
|------------------|-----------------------|---|
| Button Mode | 0 | 0 |
| Slider Mode | 0 | 1 |
| Full Slider Mode | 1 | 0 |
| Do not use | 1 | 1 |

6.8.1 Full Slider Mode

Full Slider Mode enables the AS3418 to be connected to two slide switches for Power, ANC and Monitor Mode control. To enable this operation mode register **UI_MODE** has to be set to 'd2'. The typical connection of the slide switches is shown in Figure 43.

Figure 43:
Full Slider Mode

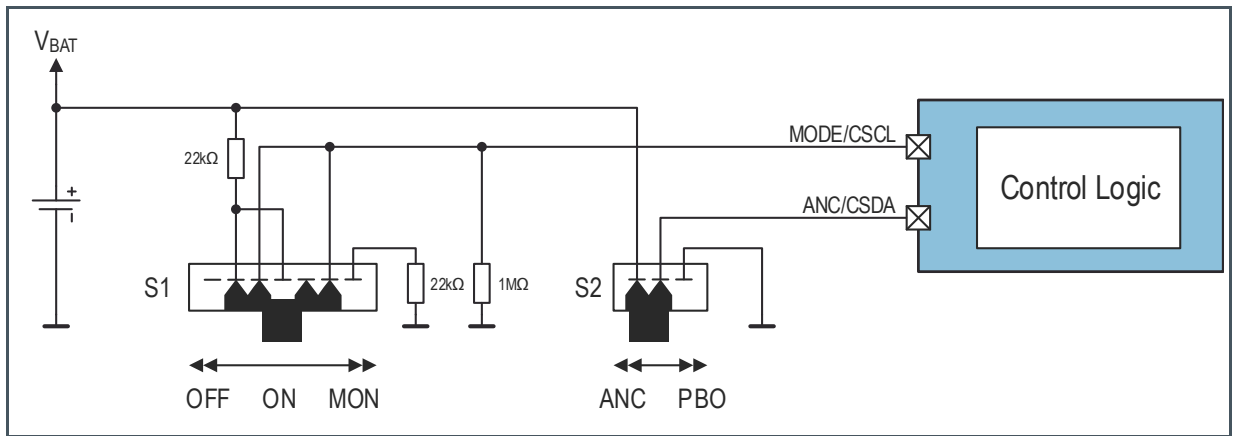

In Full Slider Mode the MODE/CSCL pin can detect three different input levels to distinguish between the different operating modes On, Off and Monitor mode. The timing diagram with all relevant information is shown in Figure 44.

Figure 44:
Full Slider Timing Diagram

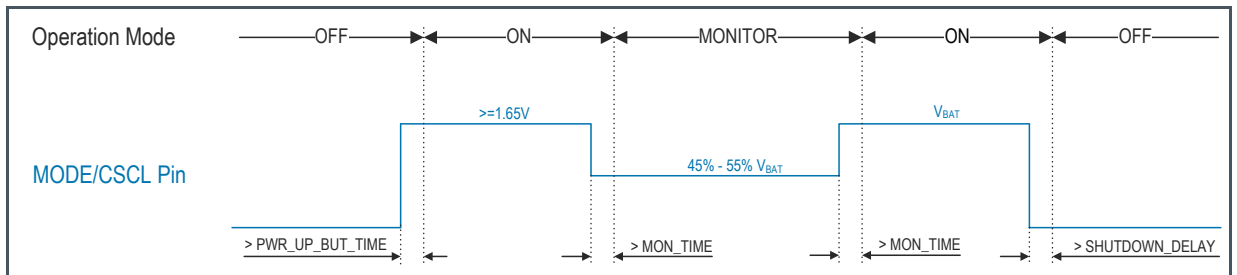

6.8.2 Slider Mode

Slider Mode is similar to Full Slider Mode with the only difference that it is possible to use a push button (S3) to enable and disable the Monitor Mode. In order to enable this operation mode, register **UI_MODE** has to be set to 'd1'. The typical connection of the slide switches and push button is shown in Figure 45.

Figure 45:
Slider Mode

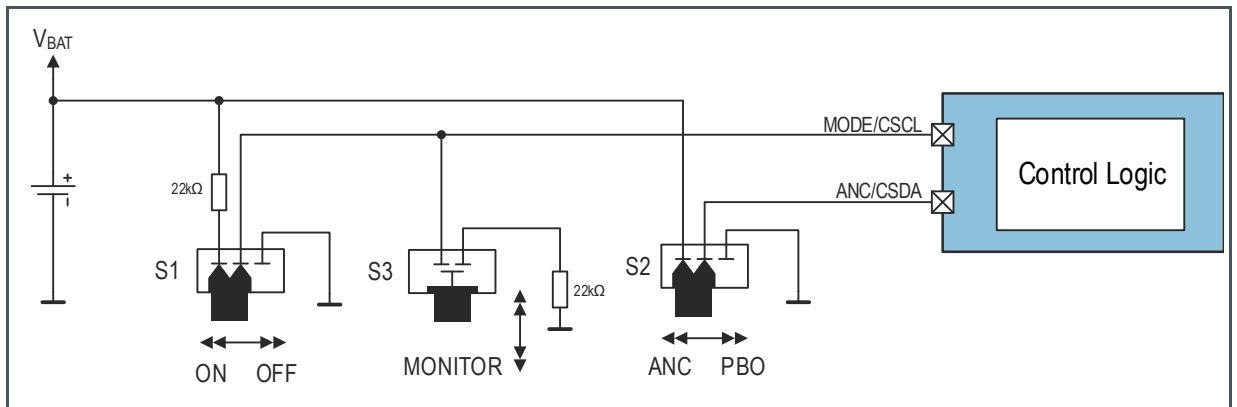

The advantage of this mode compared to Full Slider Mode is the automatic hold function of the Monitor Mode. Once the push button S3 is pressed, the device enters monitor mode. This mode stays active until the user pushes the button again.

Figure 46:
Slider Mode Timing Diagram

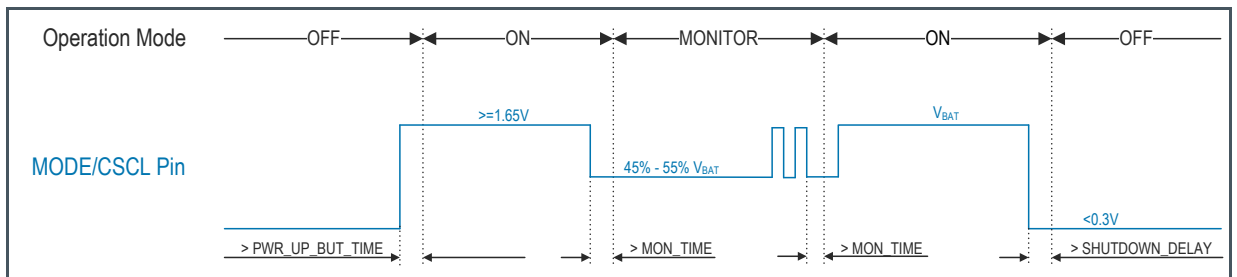

6.8.3 Push Button Mode

Push Button mode allows the user to control the device with a single normally open (NO) push button. A simple key press ($>PWR_UP_BUT_TIME$) powers up the AS3418. Once the device is running, a long key press ($>PWR_DOWN_BUT_TIME$) the device down. The device features two configuration registers ($PWR_UP_BUT_TIME$ and $PWR_DOWN_BUT_TIME$) that allows the user to re-configure the power up- and power down button press time. Monitor Mode can be activated with a second, short key press. To avoid unwanted change of operation mode it is also possible to configure the button press time (MON_TIME) to enter monitor mode. A timing diagram of this function is shown in Figure 48. If the monitor mode function is not desired, it is possible to deactivate the monitor mode by clearing the bit MON_EN in register 0x0F. The typical connection of the push button to the AS3418 is shown in Figure 47.

Figure 47:
Push Button Mode

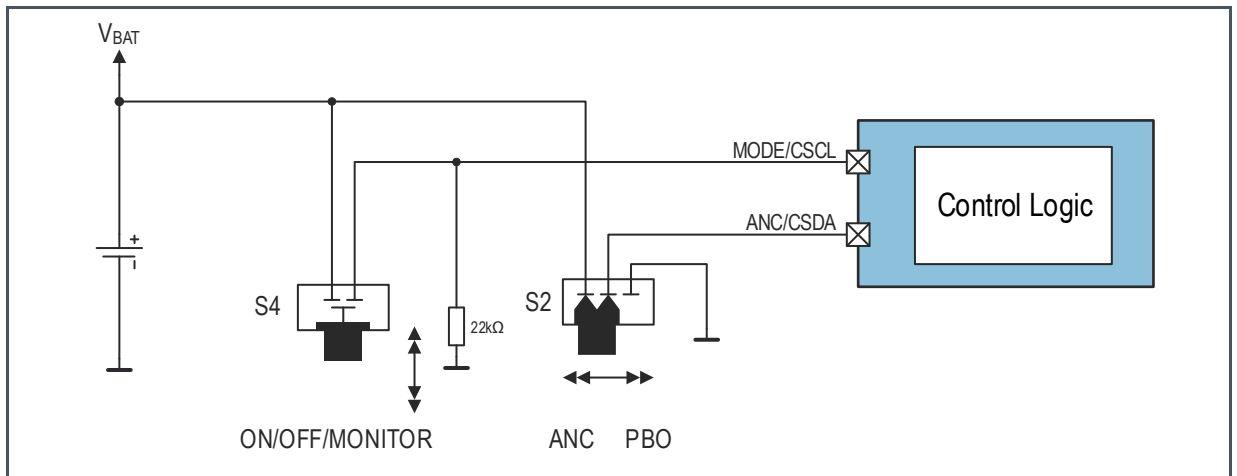
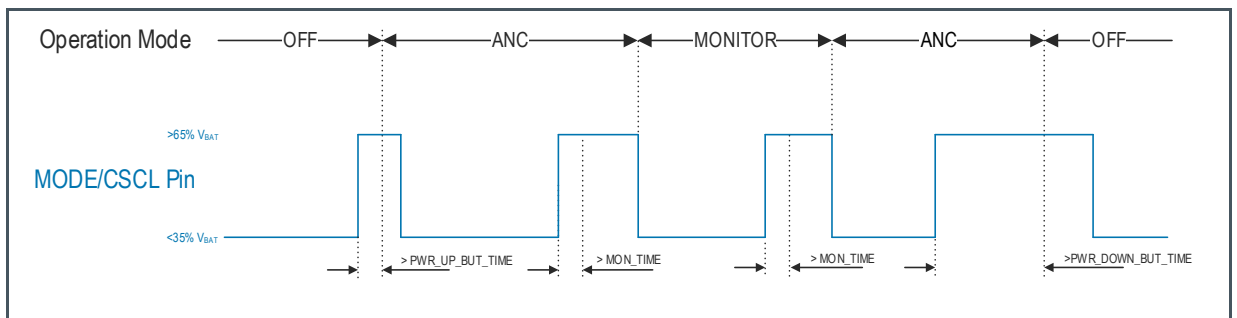

Figure 48:
Push Button Timing Diagram



6.8.4 Playback Only Mode

The active noise cancelling feature of the AS3418 can also be disabled with the ANC/CSDA pin. The ANC/CSDA pin has to be pulled high to enable the ANC function during startup (ANC MODE). If the pin is connected to ground, the chip enters playback only mode (PBO MODE) in which the ANC function can be disabled or an alternative monitor/ANC mode is configured. The functional blocks in this operation mode can be controlled in registers **PBO_MODE0** and **PBO_MODE1**. Typically only the line input amplifiers and the headphone amplifier are enabled in the playback only mode. If this function is not desired you just need to pull the pin high with an external 22kΩ resistor.

Figure 49:
Playback Only Mode Timing Diagram

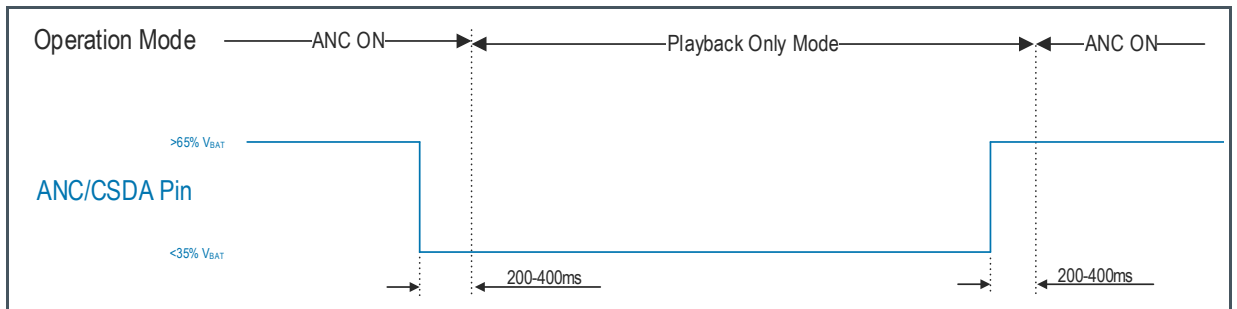

6.9 V_{NEG} Charge Pump

The V_{NEG} charge pump uses one external $2.2\mu F$ ceramic capacitor (C_{FLY}) to generate a negative supply voltage out of the input voltage to supply all audio related blocks. This allows a true-ground headphone output with no need of external DC-decoupling capacitors.

Figure 50:
 V_{NEG} Charge Pump

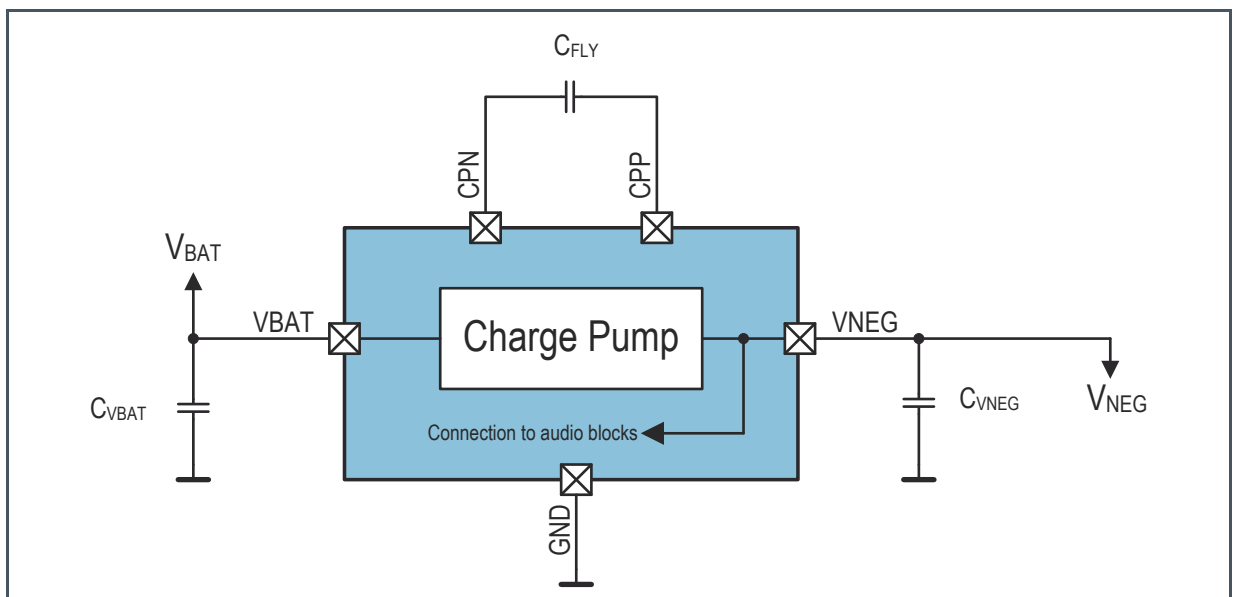

The charge pump typically requires an input capacitor C_{VBAT} with $4.7\mu F$, an output capacitor C_{VNEG} with a capacity of typ. $10\mu F$ and a flying capacitor C_{FLY} with $2.2\mu F$.

6.9.1 Parameter

$V_{BAT} = 1.8V$, $T_A = 25^\circ C$, unless otherwise specified.

Figure 51:
 V_{NEG} Charge Pump Parameter

| Symbol | Parameter | Conditions | Min | Typ | Max | Unit |
|------------|----------------------------|----------------------------|------|-----|------|---------|
| V_{IN} | Input Voltage | V_{BAT} | 1.4 | 1.6 | 1.8 | V |
| V_{OUT} | Output Voltage | V_{NEG} | -1.8 | | -1 | V |
| C_{VBAT} | V_{BAT} input capacitor | Effective capacitive value | 1.6 | 4.7 | 5.46 | μF |
| C_{VNEG} | V_{NEG} output capacitor | Effective capacitive value | 3.4 | 10 | 12 | μF |
| C_{FLY} | Flying capacitor | Effective capacitive value | 0.97 | 2.2 | 2.86 | μF |

6.10 EEPROM

The AS3418 features an integrated EEPROM that stores the system configuration data like microphone gain settings and configuration of the different operation modes during power down operation mode. Because the EEPROM is not bit addressable the AS3418 has an additional register bank in parallel to the EEPROM that is loaded with the EEPROM content during startup of the device. Each time AS3418 is powered up the EEPROM content is loaded to the register bank (0x00 – 0x1D) to configure the AS3418 according to the application requirements. The registers can be accessed via the I²C interface for embedded applications and system evaluation purpose. For non-embedded systems where no MCU is in place to configure the device there are two dedicated production trimming signal lines available that allow access to the AS3418 registers and upload/download function of the EEPROM.

Figure 52:
Register Access

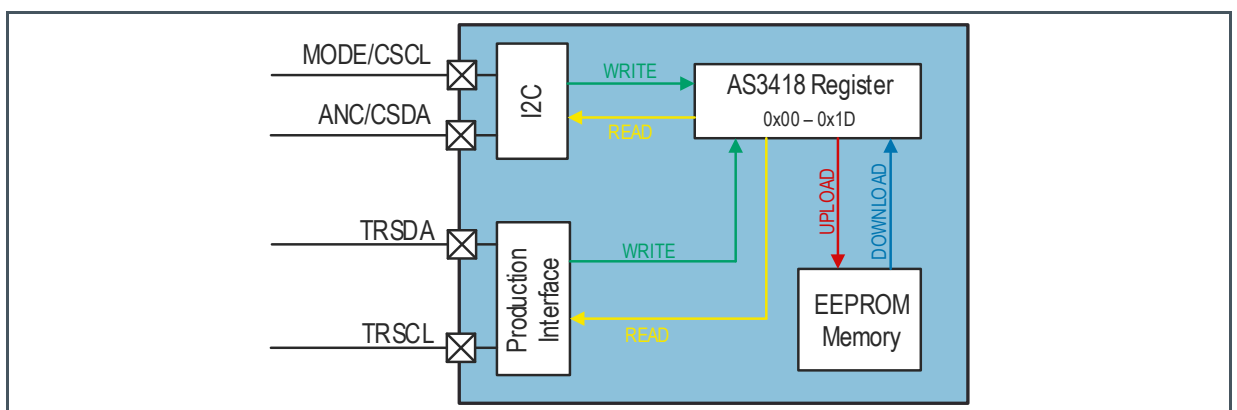

The EEPROM supports three operation modes:

- **Upload Operation** - The Upload function copies the register content of register 0x01 – 0x1D and stores it permanently to the EEPROM.
- **Download Operation** - The Download function copies the permanently stored EEPROM content to the registers of AS3418 and overwrites the existing register content with the EEPROM values like it happens during startup of the device.
- **TEST UPLOAD** - The Test Upload function is a feature to trigger a test EEPROM upload. During this test the device does not write the EEPROM settings, instead it just tries if it would be possible to write the EEPROM successfully. It is recommended to perform this test each time before a real EEPROM upload is triggered.

6.10.1 EEPROM Download Function

In order to trigger an EEPROM Download function (copy EEPROM content to AS3418 system registers) the **EEPROM_DOWNLOAD** bit has to be set in register 0x34. Once the bit is set via I²C interface or the production trimming interface the **EE_READY** bit in register 0x01 can be checked if the download of the EEPROM content is finished. As long as the **EE_READY** bit is zero the download process is ongoing. Once the bit is set the download process is completed. A flow chart of the download is shown in Figure 53.

Figure 53:
EEPROM Download Flow Chart

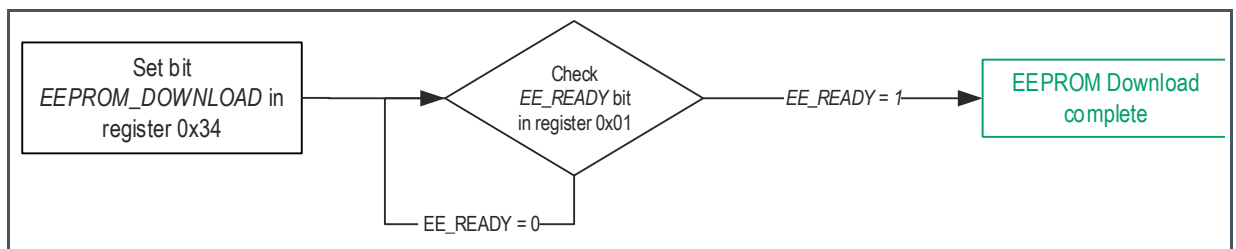

6.10.2 EEPROM Upload Function

An EEPROM Upload function can be simply triggered by setting the **EEPROM_UPLOAD** bit in register 0x34. Once the bit is set, the **EE_READY** bit has to be monitored to check the status of the EEPROM. If the Upload function is completed the **EE_READY** bit is set and the next step in the upload sequence is to check the **EE_WR_OK** bit in the same register 0x01. If the upload process was successfully completed the bit is set to '1'. In case the upload failed the bit is set to '0'. The flow chart for the EEPROM Upload sequence is shown in Figure 54.

Figure 54:
EEPROM Upload Flow Chart

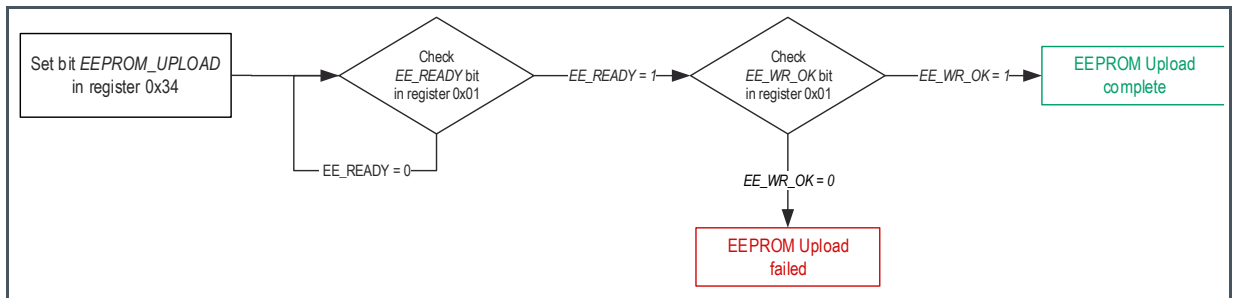

6.10.3 EEPROM Upload Test Function

Before an EEPROM Upload function is started it is recommended to do first an Upload Test. During this test the device does not write the EEPROM settings, instead it just tries if it would be possible to write the EEPROM successfully. It is checked if the power supply is sufficient to trigger a real EEPROM Upload.

Figure 55:
EEPROM Upload Test Function

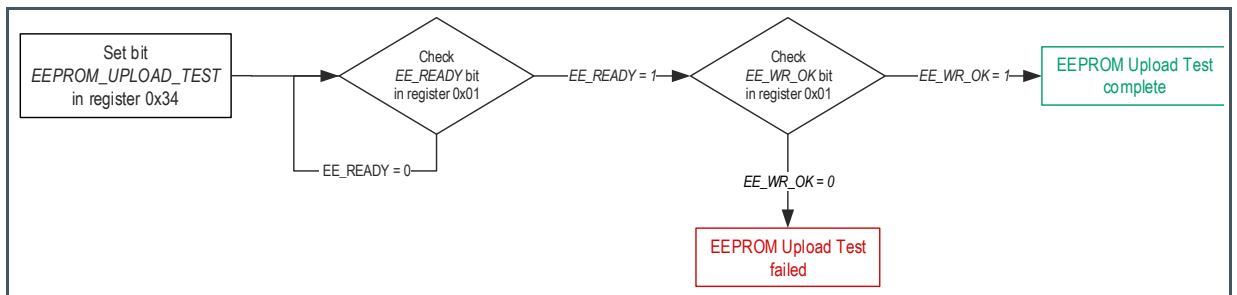

The sequence for the Upload test function is similar to the real Upload. The only difference is that the **EEPROM_UPLOAD_TEST** bit has to be set to start the upload test instead of the **EEPROM_UPLOAD** bit. The flow chart for the Upload test sequence is shown in Figure 55.

6.11 Production Trimming Interface

In addition to option programming the AS3418 via I2C interface, the AS3418 features a second unique trimming mechanism. This very special mode enables the analog music inputs of the AS3418 to become a digital production trimming input.

Figure 56:
Production Trim Box

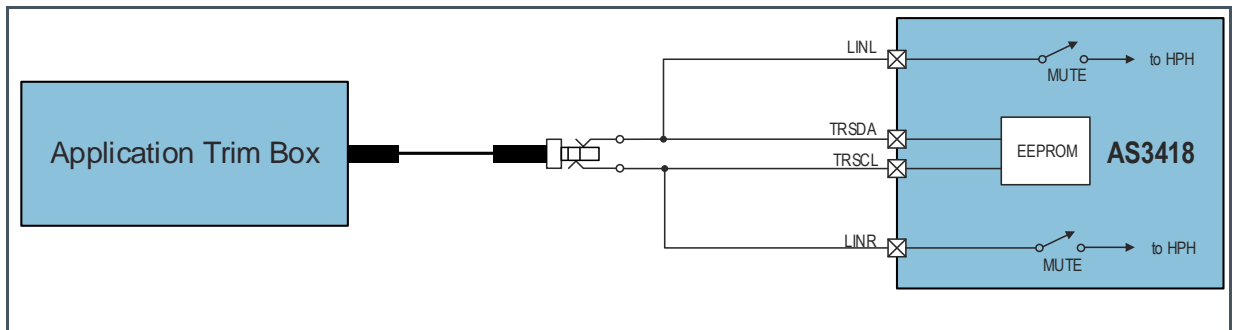

With this new system, there is no need for mechanical potentiometers any more. Up to now, operators in production used to use screw drivers to fine tune the ANC performance of each headset. The disadvantage of this is reliability and cost of potentiometers. Additionally, operators are not always precise in their work, thus yielding inconsistent results. With the production trimming system from ams there are no mechanical potentiometers required. The operator connects a 3.5mm audio jack to a trimming box and this box enables the audio input of the headset to become the ANC tuning input. This new feature also helps industrial designers of headset because there are no more considerations concerning leakage holes for the old mechanical trimming. Thus, the headset can be fully assembled and ready for the ANC test system at the end of the manufacturing process. The trim box can be easily controlled with an USB interface so it is also possible to create fully automated trimming systems. For further details please contact our local sales office; they can provide you with source code examples and application notes.

6.12 I²C Interface

In order to configure the device using the evaluation software or a MCU the AS3418 features a serial two wire interface. The I²C address for the device can be found in Figure 57.

Figure 57:
I²C Slave Address

| 7 bit I2C address | 8 Bit read address | 8 Bit write address |
|-------------------|--------------------|---------------------|
| 0x47 | 0x8F | 0x8E |

6.12.1 Protocol

Figure 58:
I2C Serial Interface Symbol Definition

| Symbol | Definition | RW | Note |
|----------|-----------------------------------|----|--------------------|
| S | Start condition after stop | R | 1 bit |
| Sr | Repeated start | R | 1 bit |
| DW | Device address for write | R | 1000 1110b (8Eh) |
| DR | Device address for read | R | 1000 1111b (8Fh) |
| WA | Word address | R | 8 bit |
| A | Acknowledge | W | 1 bit |
| N | No Acknowledge | R | 1 bit |
| reg_data | Register data/write | R | 8 bit |
| data (n) | Register data/read | W | 8 bit |
| P | Stop condition | R | 1 bit |
| WA++ | Increment word address internally | R | during acknowledge |
| | AS3418 (=slave) transmits data | | |
| | AS3418 (=slave) receives data | | |

Figure 59:
Byte Write

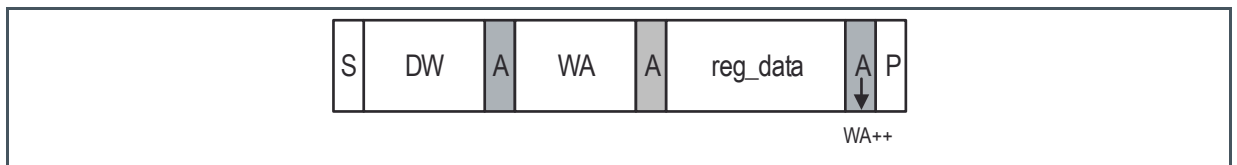
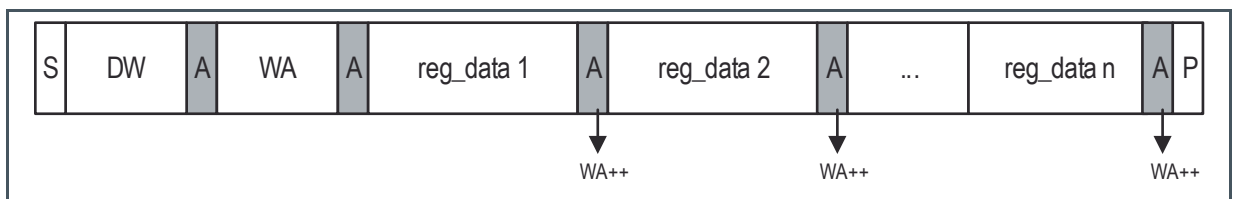

Figure 60:
Page Write



Byte Write and Page Write formats are used to write data to the slave. The transmission begins with the START condition, which is generated by the master when the bus is in IDLE state (the bus is free). The device-write address is followed by the word address. After the word address any number of data bytes can be sent to the slave. The word address is incremented internally, in order to write subsequent data bytes to subsequent address locations.

For reading data from the slave device, the master has to change the transfer direction. This can be done either with a repeated START condition followed by the device-read address, or simply with a new transmission START followed by the device-read address, when the bus is in IDLE state. The device-read address is always followed by the 1st register byte transmitted from the slave. In Read Mode any number of subsequent register bytes can be read from the slave. The word address is incremented internally.

Figure 61:
Random Read

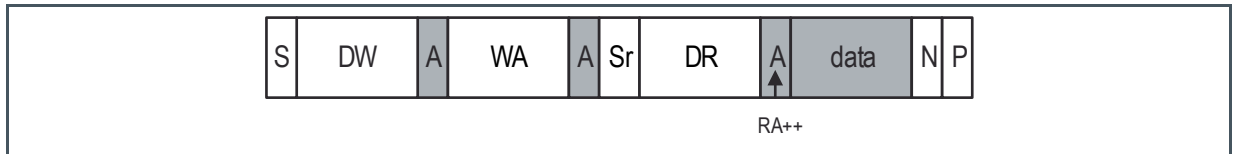

Random Read and Sequential Read are combined formats. The repeated START condition is used to change the direction after the data transfer from the master.

The word address transfer is initiated with a START condition issued by the master while the bus is idle. The START condition is followed by the device-write address and the word address.

In order to change the data direction a repeated START condition is issued on the 1st SCL pulse after the acknowledge bit of the word address transfer. After the reception of the device-read address, the slave becomes the transmitter. In this state the slave transmits register data located by the previous received word address vector. The master responds to the data byte with a not-acknowledge, and issues a STOP condition on the bus.

Figure 62:
Sequential Read

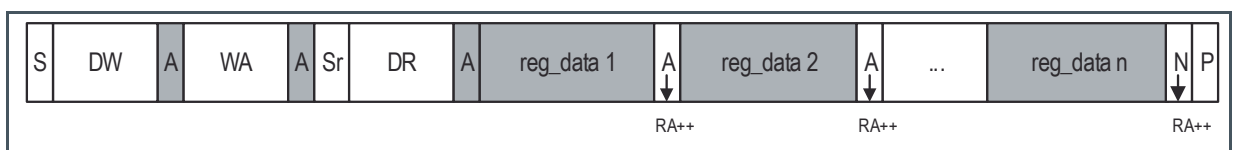

Sequential Read is the extended form of Random Read, as more than one register-data bytes are transferred subsequently. Different from the Random Read, for a sequential read, the transferred register-data bytes are responded with an acknowledge from the master. The number of data bytes transferred in one sequence is unlimited (consider the behavior of the word-address counter). To terminate the transmission the master has to send a not-acknowledge following the last data byte and then generate the STOP condition.

Figure 63:
Current Address Read

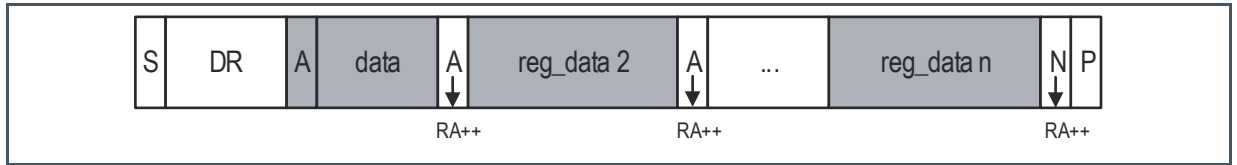

To keep the access time as short as possible, this format allows a read access without the word address transfer in advance to the data transfer. The bus is idle and the master issues a START condition followed by the Device-Read address. Analogous to Random Read, a single byte transfer is terminated with a not-acknowledge after the 1st register byte. Analogous to Sequential Read an unlimited number of data bytes can be transferred, where the data bytes have to be responded with an acknowledge from the master. For termination of the transmission, the master sends a not-acknowledge following the last data byte and a subsequent STOP condition.

6.12.2 Parameter

V_{BAT} = 1.8V, T_A = 25°C, unless otherwise specified.

Figure 64:
I²C Serial Timing

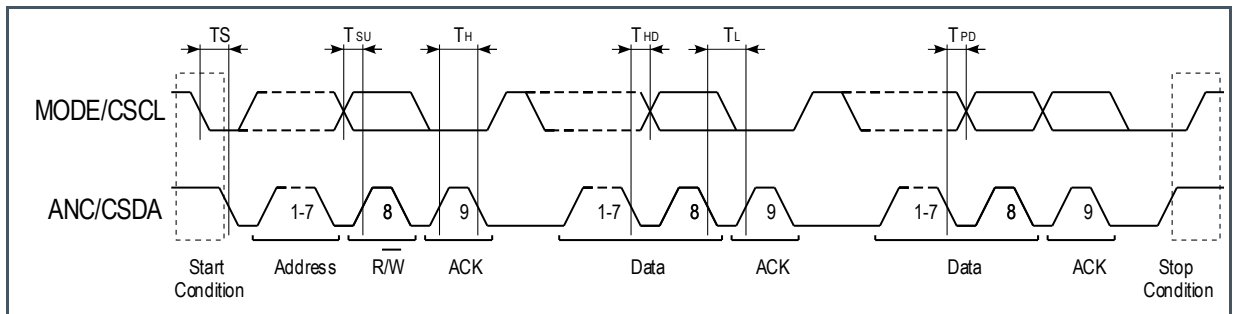

Figure 65:
I²C Serial Interface Parameter

| Symbol | Parameter | Conditions | Min | Typ | Max | Unit |
|------------------|-----------------------------|--|------|-----|------|------|
| V _{CSL} | CSCL, CSDA Low Input Level | (max 30% V _{BAT}) | 0 | - | 0.42 | V |
| V _{CSH} | CSCL, CSDA High Input Level | CSCL, CSDA (min 70% V _{BAT}) | 1.16 | - | | V |
| HYST | CSCL, CSDA Input Hysteresis | | | 450 | | mV |

| Symbol | Parameter | Conditions | Min | Typ | Max | Unit |
|----------|-----------------------|---|-----|-----|-----|------|
| V_{OL} | CSDA Low Output Level | at 3mA | - | - | 0.4 | V |
| T_{sp} | Spike insensitivity | | 50 | 100 | - | ns |
| T_H | Clock high time | max. 400kHz clock speed | 500 | | | ns |
| T_L | Clock low time | max. 400kHz clock speed | 500 | | | ns |
| T_{SU} | | CSDA has to change Tsetup before rising edge of CSCL | 250 | - | - | ns |
| T_{HD} | | No hold time needed for CSDA relative to rising edge of CSCL | 0 | - | - | ns |
| T_S | | CSDA H hold time relative to CSDA edge for start/stop/rep_start | 200 | - | - | ns |
| T_{PD} | | CSDA prop delay relative to low going edge of CSCL | | 50 | | ns |

7 Register Description

7.1 Register Overview

Figure 66:
Register Overview

| Addr | Name | <D7> | <D6> | <D5> | <D4> | <D3> | <D2> | <D1> | <D0> |
|---------------------------------------|--------------------|---------------------|-------------------------|------------------------|----------------------|----------------------|---------------------|------------------|---------------|
| System Registers | | | | | | | | | |
| 0x00 | ID | DESIGN_VERSION<3:0> | | | CHIP_ID<3:0> | | | | |
| 0x01 | SYSTEM_STATUS | - | - | - | EE_WR_TEST_OK | EE_READY | LOBAT | PWRUP_COMPLETE | PWR_HOLD |
| 0x02 | MODE_REG0 | NO_LOBAT_OFF | EN_ZERO_CROSS | DELAY_HPH_MUX | UI_MODE<1:0> | | MICS_DC_EN | HPH_MODE | I2C_MODE |
| 0x03 | MODE_REG1 | PBO_MODE_EN | MON_MODE_EN | - | ANCMON_MIC_S_CP_BYEN | ANCMON_MIC_S_CP_ON | ANCMON_MIC_S_LDO_ON | ANCMON_MIC_ON | ANCMON_HPH_ON |
| 0x04 | MICS_VOLTAGE | MICS_LDO_CV_MODE | MICS_LDO_CD_MODE | - | - | MICS_V_SEL<3:0> | | | |
| 0x05 | PUSH_DELAY | - | - | PWR_DOWN_BUT_TIME<2:0> | | PWR_UP_BUT_TIME<2:0> | | | |
| 0x06 | ON_DELAY | - | - | LDO_BOOST<2:0> | | | | ON_DELAY<2:0> | |
| 0x07 | HIQ_MODE_REG | HIQ_ECO_PRESET<1:0> | | - | - | HIQ_EN_MICS_LDO | HIQ_EN_HPH | HIQ_EN_MIC | HIQ_EN_OPAMP |
| 0x08 | LED_MON | - | - | - | MON_LED_MODE<2:0> | | MON_ILED<1:0> | | |
| 0x09 | LED_ANC | - | PBO_LED_MODE<1:0> | | - | ANC_LED_MODE<1:0> | | ANC_ILED<1:0> | |
| ANC Mode Control Registers | | | | | | | | | |
| 0x0A | ANC_MODE_REG | ANC_HPH_MUX<1:0> | | LIN_MUTE | - | - | - | ANC_OP1L_ON | ANC_OP1R_ON |
| 0x0B | ANC_MIC_LEFT_GAIN | - | ANC_MIC_LEFT_GAIN<6:0> | | | | | | |
| 0x0C | ANC_MIC_RIGHT_GAIN | - | ANC_MIC_RIGHT_GAIN<6:0> | | | | | | |
| Monitor Mode Control Registers | | | | | | | | | |
| 0x0D | MONITOR_MODE0 | MON_EN | 0 | MON_LIN_MUTE | MON_MIX_EN | 0 | 0 | MON_OP1L_ON | MON_OP1R_ON |
| 0x0E | MONITOR_MODE1 | - | - | MON_TIME<1:0> | | - | - | MON_HPH_MUX<1:0> | |

| Addr | Name | <D7> | <D6> | <D5> | <D4> | <D3> | <D2> | <D1> | <D0> |
|--|-------------------------|-----------------------|-------------------------|------------------------|------------------------|-----------------|----------------------|------------------|-----------------|
| 0x0F | MON_MIC_LEFT_GAIN | - | MON_MIC_LEFT_GAIN<6:0> | | | | | | |
| 0x10 | MON_MIC_RIGHT_GAIN | - | MON_MIC_RIGHT_GAIN<6:0> | | | | | | |
| PBO Mode Control Registers | | | | | | | | | |
| 0x11 | PBO_MODE0 | PBO_EN | - | PBO_LIN_MUTE | PBO_MIX_EN | - | - | PBO_OP1L_ON | PBO_OP1R_ON |
| 0x12 | PBO_MODE1 | - | HPH_ON/DISBYPASS | PBO_MICS_CP_BYP_EN | PBO_MICS_LD_ON | PBO_MICS_CP_ON | PBO_MIC_ON | PBO_HPH_MUX<1:0> | |
| 0x13 | PBO_MIC_LEFT_GAIN | - | PBO_MIC_LEFT_GAIN<6:0> | | | | | | |
| 0x14 | PBO_MIC_RIGHT_GAIN | - | PBO_MIC_RIGHT_GAIN<6:0> | | | | | | |
| AGC Control Registers | | | | | | | | | |
| 0x15 | AGC_CONTROL0 | ZERO_CROSS_EN | AGC_ATTACK_LEVEL<1:0> | AGC_RELEASE_LEVEL<1:0> | AGC_MUTE_EN | NEG_ATT_EN | AGC_EN | | |
| 0x16 | AGC_ATTACK_RELEASE_TIME | AGC_RELEASE_TIME<3:0> | | | AGC_ATTACK_TIME<3:0> | | | | |
| 0x17 | AGC_HOLD | ZERO_TIMEOUT<3:0> | | | HOLD_TIME<3:0> | | | | |
| 0x18 | AGC_START_TIME | - | - | - | - | - | START_RAMP_TIME<2:0> | | |
| Operation Mode Control Register | | | | | | | | | |
| 0x1A | MODE_SWITCH_CONTROL | - | SHUTDOWN_DELAY<1:0> | - | MODE_SWITCH_DELAY<1:0> | GAIN_JUMP_UP_EN | GAIN_JUMP_DOWN_EN | | |
| EEPROM Control Register | | | | | | | | | |
| 0x34 | EEPROM_CONTROL | - | - | - | - | - | EEPROM_UPLOAD_EST | EEPROM_UPLOAD | EEPROM_DOWNLOAD |

7.2 Detailed Register Description

7.2.1 System Registers

Figure 67:
ID Register Description

| Addr: 0x00 | | ID | | |
|------------|----------------|---------|--------|--|
| Bit | Bit Name | Default | Access | Bit Description |
| 7:4 | DESIGN_VERSION | 0110 | R | Design version number to identify the design version of the AS3418. 0110: Chip Version 3.0 |
| 3:0 | CHIP_ID | 0001 | R | This register represents the chip ID number of AS3418. 0001: AS3418 |

Figure 68:
SYSTEM_STATUS Register Description

| Addr: 0x01 | | SYSTEM_STATUS | | |
|------------|----------------|---------------|--------|--|
| Bit | Bit Name | Default | Access | Bit Description |
| 4 | EE_WR_TEST_OK | - | R | This register reports if an EEPROM upload test was successfully finished. This bit is also used for the EEPROM-Program-Test (together with EEPROM_UPLOAD_TEST), where a “dummy-write” can be initialized to check the power-supply 0: EEPROM upload TEST failed 1: EEPROM upload TEST successful |
| 3 | EE_READY | - | R | This registers indicates the status after a read/write command of the EEPROM. 0: EEPROM busy 1: EEPROM ready |
| 1 | PWRUP_COMPLETE | 1 | R | This bit indicates the Power-Up sequencer status of AS3418. The signal goes high after all amplifiers are enabled but before the microphone signal is faded in. 0: Power-up sequence incomplete 1: Power-up sequence completed |
| 0 | PWR_HOLD | 1 | R/W | This bit allows an MCU, using the I ² C interface, to power down the AS3418. A start condition on the I ² C interface will wake up the device again. This function |

| Addr: 0x01 | | SYSTEM_STATUS | | |
|------------|----------|---------------|--------|---|
| Bit | Bit Name | Default | Access | Bit Description |
| | | | | works only if the I2C_MODE bit is set. In case I2C_MODE is low, the register content is ignored. 0: Power up hold is cleared and chip powers down 1: Device remains powered on |

Figure 69:
MODE_REG0 Register Description

| Addr: 0x02 | | MODE_REG0 | | |
|------------|---------------|-----------|--------|---|
| Bit | Bit Name | Default | Access | Bit Description |
| 6 | EN_ZERO_CROSS | 1 | R/W | This bit activates zero cross detection while switching between music bypass switch and headphone amplifier. 0: Zero cross detection is disabled. 1: Zero cross detection is enabled. |
| 5 | DELAY_HPH_MUX | 0 | R/W | This register controls the startup delay setting before the ANC_HPH_MUX setting is applied to the system. This function can help to reduce pop noise during startup of the device especially if there are components with long charging times involved. This bit is only valid during initial startup. 0: Headphone MUX delay disabled 1: Headphone MUX delay enabled |
| 4:3 | UI_MODE | 01 | R/W | This register defines the user interface operation mode of AS3418. For a detailed description of the different user interface modes please refer to chapter Operation Modes. 00: Push Button Operation Mode 01: Slider Operation Mode 10: Full Slider Operation 11: Do not use |
| 2 | MICS_DC_EN | 1 | R/W | This bit enables the internal microphone supply discharge function if the microphone supply is switched off. The MICS_LDO pin is discharged within ~10ms. 0: MICS_LDO discharge disabled 1: MICS_LDO discharge enabled |
| 1 | HPH_MODE | 0 | R/W | This register controls the operation mode of the headphone amplifier. The headphone amplifier supports single ended mode and differential mode. In differential output mode the right audio signal path is the active input signal for the headphone amplifier. |

| Addr: 0x02 | | MODE_REG0 | | |
|---|----------|-----------|--------|---|
| Bit | Bit Name | Default | Access | Bit Description |
| <p>0: Stereo single ended mode 1: Mono differential mode</p> | | | | |
| 0 | I2C_MODE | 0 | R/W | <p>All registers can be read and written by the I²C interface independent on the level of I2C_MODE bit but I2C_MODE controls whether the main modes of AS3418 (MON/ANC/PBO/ON/OFF) are controlled by the MON_MODE_EN, PBO_MODE_EN bits and SYSTEM_STATUS registers or by the buttons and switches. Once the bit is set and the system powers up because there's an I²C start condition applied to the CSCL and CSDA pins, the user has to write the PWR_HOLD bit within SHUTDOWN_DELAY, otherwise AS3418 powers down again.</p> <p>This can be done either over the CSDA/CSCL or over the application trimming interface.</p> <p>0: I²C mode control functions disabled 1: I²C mode control functions enabled</p> |

Figure 70:
MODE_REG1 Register Description

| Addr: 0x03 | | MODE_REG1 | | |
|------------|--------------------|-----------|--------|--|
| Bit | Bit Name | Default | Access | Bit Description |
| 7 | PBO_MODE_EN | 0 | R/W | <p>In case I2C_MODE bit is not set, the register content is ignored but can be read and written. In case I2C_MODE bit is set, this bit controls the operation mode of AS3418 (ANC, MON, PBO). In case the PBO_MODE_EN is 1, MON_MODE_EN has to be 0.</p> <p>0: ANC Mode 1: PBO Mode</p> |
| 6 | MON_MODE_EN | 0 | R/W | <p>In case I2C_MODE bit is not set, the register content is ignored but can be read and written. In case I2C_MODE bit is set, this bit controls the operation mode of AS3418 (ANC, MON, PBO). In case the PBO_MODE_EN is 1, MON_MODE_EN has to be 0.</p> <p>0: ANC Mode 1: MON Mode</p> |
| 4 | ANCMON_MICS_BYP_EN | 0 | R/W | <p>This bit enables the automatic VBAT to MICS bypass function when the microphone supply charge pump is switched off. This function has to be activated in case the microphone supply voltage regulator is supplied externally via MICS_CP pin.</p> |

| Addr: 0x03 | | MODE_REG1 | | |
|------------|--------------------|-----------|--------|--|
| Bit | Bit Name | Default | Access | Bit Description |
| | | | | 0: MIC charge pump bypass function disabled 1: MIC charge pump bypass function enabled |
| 3 | ANCMON_MICS_CP_ON | 1 | R/W | This bit controls the microphone supply charge pump. The microphone charge pump has a second function besides the bias voltage generation for microphones. It is also used to disable the integrated music bypass switch if the AS3418 is active. In case the integrated bypass switch is used in an application this bit must not be set to '0'. 0: Microphone supply charge pump disabled 1: Microphone supply charge pump enabled WARNING: Microphone supply is also used for disabling the Bypass switch. If Microphone supply is disabled an external supply is required. |
| 2 | ANCMON_MICS_LDO_ON | 1 | R/W | This bit controls the microphone supply. In case this bit is set to '1' the microphone supply voltage regulator (MICS output pin) is powered up. 0: Microphone supply switched off 1: Microphone supply switched on |
| 1 | ANCMON_MICS_ON | 1 | R/W | This bit powers up the microphone preamplifier. 0: Microphone preamplifier disabled 1: Microphone preamplifier enabled |
| 0 | ANCMON_HP_H_ON | 1 | R/W | This bit allows the user to power down headphone amplifier in case it is not used in the final application in order to save system power. 0: Headphone amplifier disabled 1: Headphone amplifier enabled |

Figure 71:
MICS_VOLTAGE Register Description

| Addr: 0x04 | | MICS_VOLTAGE | | |
|------------|------------------|--------------|--------|--|
| Bit | Bit Name | Default | Access | Bit Description |
| 7 | MICS_LDO_CV_MODE | - | R | Signals if the MICS_LDO is in constant voltage mode. 1: Constant voltage mode active 0: Constant voltage mode inactive |
| 6 | MICS_LDO_CD_MODE | - | R | Signals if the microphone supply is in constant drop mode 1: Constant drop mode active 0: Constant drop mode inactive |

| Addr: 0x04 | | MICS_VOLTAGE | | |
|------------|------------|--------------|--------|---|
| Bit | Bit Name | Default | Access | Bit Description |
| | | | | This register controls the output voltage of the integrated microphone supply regulator. 0000: 1.6V 0001: 1.7V 0010: 1.8V 0011: 1.9V 0100: 2.0V 0101: 2.1V 0110: 2.2V 0111: 2.3V 1000: 2.4V 1001: 2.5V 1010: 2.6V 1011: 2.7V(default) 1100: 2.8V 1101: 2.9V 1110: Do not use ... 1111: Do not use |
| 3:0 | MICS_V_SEL | 1011 | R/W | |

Figure 72:
PUSH_DELAY Register Description

| Addr: 0x05 | | PUSH_DELAY | | |
|------------|-------------------|------------|--------|--|
| Bit | Bit Name | Default | Access | Bit Description |
| | | | | This register controls the hold time for the push button in order to power down the AS3418. Depending on the register setting the power down push button time can be programmed accordingly. This delay is applied for button, slider and full slider mode. 000: 5ms 001: 500ms 010: 1000ms 011: 1500ms 100: 2000ms 101: 2500ms 110: 2500ms 111: 2500ms |
| 5:3 | PWR_DOWN_BUT_TIME | 111 | R/W | |

| Addr: 0x05 | | PUSH_DELAY | | |
|------------|-----------------|------------|--------|---|
| Bit | Bit Name | Default | Access | Bit Description |
| 2:0 | PWR_UP_BUT_TIME | 000 | R/W | <p>This register controls the hold time for the push button in order to power up the AS3418. Depending on the register setting the power up push button time can be programmed accordingly. This delay is applied for button, slider and full slider mode.</p> <p>000: 5ms 001: 500ms 010: 1000ms 011: 1500ms 100: 2000ms 101: 2500ms 110: 2500ms 111: 2500ms</p> |

Figure 73:
ON_DELAY Register Description

| Addr: 0x06 | | ON_DELAY | | |
|------------|-----------|----------|--------|--|
| Bit | Bit Name | Default | Access | Bit Description |
| 5:3 | LDO_BOOST | 001 | R/W | <p>This register controls the pre-charge time of the microphone supply LDO. LDO_BOOST is effective not only during startup but also whenever the LDO is enabled after startup.</p> <p>000: 0ms 001: 150ms 010: 400ms 011: 600ms 100: 800ms 101: 1000ms 110: 1200ms 111: 1500ms</p> |
| 2:0 | ON_DELAY | 000 | R/W | <p>This register controls the power on delay setting. If this register is set, the device powers up but stays in a Mute mode with the integrated bypass switches deactivated to block unwanted noise at the line input.</p> <p>000: 0ms 001: 200ms 010: 400ms 011: 600ms 100: 800ms 101: 1200ms</p> |

| Addr: 0x06 | | ON_DELAY | | |
|------------|----------|----------|--------|-----------------|
| Bit | Bit Name | Default | Access | Bit Description |
| | | | | 110: 1600ms |
| | | | | 111: 2000ms |

Figure 74:
 ECO_MODE_REG Register Description

| Addr: 0x07 | | ECO_MODE_REG | | |
|------------|---------------------|--------------|--------|---|
| Bit | Bit Name | Default | Access | Bit Description |
| 7:6 | HIQ_ECO_PR ESET | 00 | R/W | This register allows the device to achieve best offset performance. Depending on the quality settings of headphone amplifier, microphone pre-amplifier and OP1 the correct preset from the table below has to be configured to ensure lowest offset values. 00: HPH->HIQ; MIC->HIQ; OP1->HIQ 01: HPH->HIQ; MIC->ECO; OP1->ECO 10: HPH->HIQ; MIC->HIQ; OP1->ECO 11: HPH->ECO; MIC->ECO; OP1->ECO |
| 3 | HIQ_EN_MIC S_LDO | 1 | R/W | This bit enables the high quality mode of the microphone LDO. 0: High quality function disabled 1: High quality function enabled |
| 2 | HIQ_EN_HPH | 1 | R/W | This bit enables the high quality mode of the headphone amplifier. 0: High quality function disabled 1: High quality function enabled |
| 1 | HIQ_EN_MIC | 1 | R/W | This bit enables the high quality mode of the microphone amplifier. 0: High quality function disabled 1: High quality function enabled |
| 0 | HIQ_EN_OPA MP | 1 | R/W | This bit enables the high quality mode of the operational amplifiers for ANC filter design. 0: High quality function disabled 1: High quality function enabled |

Figure 75:
LED_MON Register Description

| Addr: 0x08 | | LED_MON | | |
|------------|--------------|---------|--------|---|
| Bit | Bit Name | Default | Access | Bit Description |
| 4:2 | MON_LED_MODE | 000 | R/W | <p>This register controls blinking time of LED in MON mode.</p> <p>000: LED always on</p> <p>001: 80ms PWM active / 80ms off 010: 80ms PWM active / 160ms off 011: 80ms PWM active / 240ms off 100: 80ms PWM active / 320ms off 101: 80ms PWM active / 400ms off 110: 80ms PWM active / 480ms off 111: 80ms PWM active / 560ms off</p> |
| 1:0 | MON_ILED | 00 | R/W | <p>This register controls the integrated LED driver current sink of the AS3418 in Monitor operation mode.</p> <p>00: ILED current sink switched off</p> <p>01: 25% duty cycle (4µs on/ 14µs off) 10: 50% duty cycle (9µs on/ 9µs off) 11: 100% duty cycle (18µs on/ 0µs off)</p> |

Figure 76:
LED_ANC Register Description

| Addr: 0x09 | | LED_ANC | | |
|------------|--------------|---------|--------|---|
| Bit | Bit Name | Default | Access | Bit Description |
| 6:5 | PBO_LED_MODE | 00 | R/W | <p>Defines the blinking scheme if PBO mode is active. Please note that PBO mode has not an individual LED control register. Therefore this setting uses hardcoded 25% PWM duty cycle for brightness.</p> <p>00: LED always off</p> <p>01: Blinking scheme as in ANC mode 10: Blinking scheme as in MON mode 11: LED always on (=PWM always active)</p> |
| 3:2 | ANC_LED_MODE | 00 | R/W | <p>This register controls the different LED effects for ANC mode with various on/off times as well as different flash frequencies.</p> <p>00: LED always on</p> <p>01: 80ms on / 1s off 10: 80ms on / 1.5s off</p> |

| Addr: 0x09 | | LED_ANC | | |
|--|----------|---------|--------|--|
| Bit | Bit Name | Default | Access | Bit Description |
| 11: 80ms on / 2.5s off | | | | |
| This register controls the integrated LED driver current sink of the AS3418 in ANC operation mode. The typical PWM frequency is $1/18\mu\text{s}=55.6\text{kHz}$. | | | | |
| 1:0 | ANC_ILED | 00 | R/W | 00: ILED current sink switched off 01: 25% duty cycle (4 μs on/ 14 μs off) 10: 50% duty cycle (9 μs on/ 9 μs off) 11: 100% duty cycle (18 μs on/ 0 μs off) |

7.2.2 ANC Mode Control Registers

Figure 77:
 ANC_MODE_REG Register Description

| Addr: 0x0A | | ANC_MODE_REG | | |
|------------|-------------|--------------|--------|---|
| Bit | Bit Name | Default | Access | Bit Description |
| 7:6 | ANC_HPH_MUX | 11 | R/W | This register selects the ANC input source for the headphone amplifier in ANC mode. Depending on the register, setting different outputs are routed to the headphone amplifier input. It is also possible to disconnect all ANC input sources which is sometimes desired in monitor mode. 00: QMIC outputs are connected to HPH input 01: OP1 outputs are connected to HPH input 10: Do not use this setting 11: Nothing connected to HPH input except line input in case it is enabled. |
| 5 | LIN_MUTE | 0 | R/W | This bit mutes the line input signal. If the bit is set the line input signal is disconnected from the headphone amplifier in ANC operation mode. 0: Line input signal enabled 1: Line input signal muted |
| 1 | ANC_OP1L_ON | 0 | R/W | This register enables the left channel of OPAMP 1 in ANC operation mode. 0: Left OP1 is switched off 1: Left OP1 is switched on |
| 0 | ANC_OP1R_ON | 0 | R/W | This register enables the right channel of OPAMP 1 in ANC operation mode. 0: Right OP1 is switched off |

| Addr: 0x0A | | ANC_MODE_REG | | |
|------------|----------|--------------|--------|-----------------------------|
| Bit | Bit Name | Default | Access | Bit Description |
| | | | | 1: Right OP1 is switched on |

Figure 78:
ANC_MIC_LEFT_GAIN Register Description

| Addr: 0x0B | | ANC_MIC_LEFT_GAIN | | |
|------------|-------------------|-------------------|--------|---|
| Bit | Bit Name | Default | Access | Bit Description |
| 6:0 | ANC_MIC_LEFT_GAIN | 101 0111 | R/W | Volume settings for left microphone input, adjustable in 63 steps of 0.5dB for ANC operation mode. 000 0000: 0dB 000 0001: 0.5dB gain 000 0010: 1.0dB gain 000 0011: 1.5dB gain ... 011 1110: 31dB gain 011 1111: Do not use 101 0111: MUTE (Mute code if NEG_ATT_EN bit set) 111 1111: MUTE (Mute code if NEG_ATT_EN bit not set) |

Figure 79:
ANC_MIC_RIGHT_GAIN Register Description

| Addr: 0x0C | | ANC_MIC_RIGHT_GAIN | | |
|------------|--------------------|--------------------|--------|---|
| Bit | Bit Name | Default | Access | Bit Description |
| 6:0 | ANC_MIC_RIGHT_GAIN | 101 0111 | R/W | Volume settings for right microphone input, adjustable in 63 steps of 0.5dB for ANC operation mode. 000 0000: 0dB 000 0001: 0.5dB gain 000 0010: 1.0dB gain 000 0011: 1.5dB gain ... 011 1110: 31dB gain 011 1111: Do not use 101 0111: MUTE (Mute code if NEG_ATT_EN bit set) |

| Addr: 0x0C | | ANC_MIC_RIGHT_GAIN | | |
|---|----------|--------------------|--------|-----------------|
| Bit | Bit Name | Default | Access | Bit Description |
| 111 1111: MUTE (Mute code if <i>NEG_ATT_EN</i> bit not set) | | | | |

7.2.3 Monitor Mode Control Registers

Figure 80:
MONITOR_MODE0 Register Description

| Addr: 0x0D | | MONITOR_MODE0 | | |
|------------|--------------|---------------|--------|---|
| Bit | Bit Name | Default | Access | Bit Description |
| 7 | MON_EN | 1 | R/W | This bit disables the monitor mode function in all operation modes. 0: Monitor mode disabled 1: Monitor mode enabled |
| 5 | MON_LIN_MUTE | 1 | R/W | This bit enables mute function for the line input in monitor more. 0: Line input enabled in Monitor mode 1: Line input muted in Monitor mode |
| 1 | MON_OP1L_ON | 0 | R/W | This register enables the left channel of OPAMP 1 in MON operation mode. 0: Left OP1 is switched off 1: Left OP1 is switched on |
| 0 | MON_OP1R_ON | 0 | R/W | This register enables the right channel of OPAMP 1 in MON operation mode. 0: Right OP1 is switched off 1: Right OP1 is switched on |

Figure 81:
MONITOR_MODE1 Register Description

| Addr: 0x0E | | MONITOR_MODE1 | | |
|------------|---------------|---------------|--------|--|
| Bit | Bit Name | Default | Access | Bit Description |
| 5:4 | MON_TIME<1:0> | 00 | R/W | Time needed to press the monitor switch until monitor mode is activated. 00: 25ms 01: 200ms |

| Addr: 0x0E | | MONITOR_MODE1 | | |
|------------|----------------------|---------------|--------|---|
| Bit | Bit Name | Default | Access | Bit Description |
| | | | | 10: 400ms 11: 600ms |
| 1:0 | MON_HPH_M UX<1:0> | 00 | R/W | <p>This register selects the ANC input source for the headphone amplifier in Monitor mode. Depending on the register setting different outputs are routed to the headphone amplifier input. It is also possible to disconnect all ANC input sources which is sometimes desired in monitor mode.</p> <p>00: QMIC outputs are connected to HPH input 01: OP1 outputs are connected to HPH input 10: Do not use (reserved for OP2) 11: QMIC, OP1 are disconnected from HPH</p> |

Figure 82:
MON_MIC_LEFT_GAIN Register Description

| Addr: 0x0F | | MON_MIC_LEFT_GAIN | | |
|------------|-----------------------|-------------------|--------|--|
| Bit | Bit Name | Default | Access | Bit Description |
| 6:0 | MON_MIC_LE FT_GAIN | 101 0111 | R/W | <p>Volume settings for left microphone input, adjustable in 63 steps of 0.5dB for Monitor operation mode.</p> <p>000 0000: 0dB 000 0001: 0.5dB gain 000 0010: 1.0dB gain 000 0011: 1.5dB gain ... 011 1110: 31dB gain 011 1111: Do not use</p> <p>101 0111: MUTE (Mute code if NEG_ATT_EN bit set) 111 1111: MUTE (Mute code if NEG_ATT_EN bit not set)</p> |

Figure 83:
MON_MIC_RIGHT_GAIN Register Description

| Addr: 0x10 | | MON_MIC_RIGHT_GAIN | | |
|------------|--------------------|--------------------|--------|---|
| Bit | Bit Name | Default | Access | Bit Description |
| 6:0 | MON_MIC_RIGHT_GAIN | 101 0111 | R/W | <p>Volume settings for right microphone input, adjustable in 63 steps of 0.5dB for Monitor operation mode.</p> <p>000 0000: 0dB 000 0001: 0.5dB gain 000 0010: 1.0dB gain 000 0011: 1.5dB gain ... 011 1110: 31dB gain 011 1111: do not use 101 0111: MUTE (Mute code if NEG_ATT_EN bit set) 111 1111: MUTE (Mute code if NEG_ATT_EN bit not set)</p> |

7.2.4 PBO Mode Control Registers

Figure 84:
PBO_MODE0 Register Description

| Addr: 0x11 | | PBO_MODE0 | | |
|------------|---------------|-----------|--------|--|
| Bit | Bit Name | Default | Access | Bit Description |
| 7 | PBO_EN | 1 | R/W | <p>This bit disables the Playback Only mode function in all modes. No external pull up resistor is required on ANC / CSDA pin if this bit is set to '0'.</p> <p>0: Playback only mode disabled 1: Playback only mode enabled</p> |
| 5 | PBO_LINE_MUTE | 0 | R/W | <p>This bit mutes the line input in Playback Only operation mode.</p> <p>0: Line input enabled 1: Line input muted</p> |
| 1 | PBO_OP1L_ON | 0 | R/W | <p>This register enables the left channel of OPAMP 1 in playback only mode.</p> <p>0: Left OP1 is switched off 1: Left OP1 is switched on</p> |

| Addr: 0x11 | | PBO_MODE0 | | |
|------------|-------------|-----------|--------|---|
| Bit | Bit Name | Default | Access | Bit Description |
| 0 | PBO_OP1R_ON | 0 | R/W | This register enables the right channel of OPAMP 1 in playback only mode. 0: Right OP1 is switched off 1: Right OP1 is switched on |

Figure 85:
PBO_MODE1 Register Description

| Addr: 0x12 | | PBO_MODE1 | | |
|------------|--------------------|-----------|--------|---|
| Bit | Bit Name | Default | Access | Bit Description |
| 6 | HPH_ON/DIS_BYPASS | 0 | R/W | This register disables the headphone amplifier in Playback Only mode and enables the integrated music bypass switch. 0: Headphone amplifier disabled/ Bypass enabled 1: Headphone amplifier enabled |
| 5 | PBO_MICS_CP_BYP_EN | 0 | R/W | This bit disables the automatic charge pump bypass function if the microphone supply charge pump is in off mode. 0: Charge Pump bypass disabled 1: Charge Pump bypass enabled |
| 4 | PBO_MICS_LDO_ON | 1 | R/W | This bit enables the microphone LDO in Playback Only operation mode. 0: Microphone Supply voltage LDO regulator disabled 1: Microphone Supply voltage LDO regulator enabled |
| 3 | PBO_MICS_CP_ON | 1 | R/W | This bit controls the microphone supply charge pump. Please mind that disabling the charge pump automatically activates the integrated music bypass switch. 0: Microphone supply charge pump disabled 1: Microphone supply charge pump enabled |
| 2 | PBO_MIC_ON | 0 | R/W | This register controls the microphone preamplifier in Playback Only operation mode. 0: Microphone preamplifier disabled 1: Microphone preamplifier enabled |
| 1:0 | PBO_HPH_MUX | 11 | R/W | This register selects the input source of the headphone amplifier in Playback Only operation mode. Depending on register setting the microphone |

| Addr: 0x12 | | PBO_MODE1 | | |
|------------|----------|-----------|--------|---|
| Bit | Bit Name | Default | Access | Bit Description |
| | | | | <p>preamplifier or OPAMP1 can be connected to the headphone amplifier input.</p> <p>00: QMIC outputs are connected to HPH input</p> <p>01: OP1 outputs are connected to HPH input</p> <p>10: Do not use</p> <p>11: Nothing connected to HPH input except line input.</p> |

Figure 86:
PBO_MIC_LEFT_GAIN Register Description

| Addr: 0x13 | | PBO_MIC_LEFT_GAIN | | |
|------------|-------------------|-------------------|--------|--|
| Bit | Bit Name | Default | Access | Bit Description |
| 6:0 | PBO_MIC_LEFT_GAIN | 101 0111 | R/W | <p>Volume settings for left microphone input, adjustable in 63 steps of 0.5dB for PBO operation mode.</p> <p>000 0000: 0dB</p> <p>000 0001: 0.5dB gain</p> <p>000 0010: 1.0dB gain</p> <p>000 0011: 1.5dB gain</p> <p>...</p> <p>011 1110: 31dB gain</p> <p>011 1111: do not use</p> <p>101 0111: MUTE (Mute code if NEG_ATT_EN bit set)</p> <p>111 1111: MUTE (Mute code if NEG_ATT_EN bit not set)</p> |

Figure 87:
PBO_MIC_RIGHT_GAIN Register Description

| Addr: 0x14 | | PBO_MIC_RIGHT_GAIN | | |
|------------|--------------------|--------------------|--------|---|
| Bit | Bit Name | Default | Access | Bit Description |
| 6:0 | PBO_MIC_RIGHT_GAIN | 101 0111 | R/W | <p>Volume settings for right microphone input, adjustable in 63 steps of 0.5dB for PBO operation mode.</p> <p>000 0000: 0dB</p> <p>000 0001: 0.5dB gain</p> <p>000 0010: 1.0dB gain</p> |

| Addr: 0x14 | | PBO_MIC_RIGHT_GAIN | | |
|------------|----------|--------------------|--------|---|
| Bit | Bit Name | Default | Access | Bit Description |
| | | | | 000 0011: 1.5dB gain |
| | | | | ... |
| | | | | 011 1110: 31dB gain |
| | | | | 011 1111: do not use |
| | | | | 101 0111: MUTE (Mute code if NEG_ATT_EN bit set) |
| | | | | 111 1111: MUTE (Mute code if NEG_ATT_EN bit not set) |

7.2.5 AGC Control Registers

Figure 88:
AGC_CONTROL0 Register Description

| Addr: 0x15 | | AGC_CONTROL0 | | |
|------------|---------------|--------------|--------|--|
| Bit | Bit Name | Default | Access | Bit Description |
| 7 | ZERO_CROSS_EN | 0 | R/W | This register disables the zero cross detection function of the AGC. 0: Zero cross detection disabled 1: Zero cross detection enabled |
| 6:5 | ATTACK_LEVEL | 0 | R/W | This register controls the attack level threshold voltage of the AGC. 00: 0.277* V_{BAT} attack level 01: 0.333* V _{BAT} attack level 10: 0.395* V _{BAT} attack level 11: 0.463* V _{BAT} attack level |
| 4:3 | RELEASE_LEVEL | 00 | R/W | This register controls the release level threshold voltage of the AGC. 00: 0.200* V_{BAT} release level 01: 0.250* V _{BAT} release level 10: 0.304* V _{BAT} release level 11: 0.364* V _{BAT} release level |
| 2 | AGC_MUTE_EN | 0 | R/W | This bit enables the mute function for the automatic gain control. 0: AGC mute function disabled 1: AGC mute function enabled |

| Addr: 0x15 | | AGC_CONTROL0 | | |
|------------|--------------|--------------|--------|---|
| Bit | Bit Name | Default | Access | Bit Description |
| 1 | NEG_ATTEN_EN | 0 | R/W | <p>This bit enables negative the negative gain option for the microphone preamplifier in case of a microphone overload condition. The gain can go down to -40dB. In case the AGC_MUTE_EN bit is not. If the AGC_MUTE_EN bit is set the preamplifier goes to -40dB and eventually mutes the output.</p> <p>0: Negative attenuation disabled 1: Negative attenuation enabled</p> |
| 0 | AGC_EN | 0 | R/W | <p>This bit enables/disabled the automatic gain control function of AS3418. This setting is valid for ANC, Monitor and PBO operation mode.</p> <p>0: AGC disabled 1: AGC enabled</p> |

Figure 89:
AGC_ATTACK_RELEASE_TIME Register Description

| Addr: 0x16 | | AGC_ATTACK_RELEASE_TIME | | |
|------------|------------------|-------------------------|--------|---|
| Bit | Bit Name | Default | Access | Bit Description |
| 7:4 | AGC_RELEASE_TIME | 0001 | R/W | <p>This register controls the AGC release time.</p> <p>0000: 0ms 0001: 0.5ms 0010: 1ms 0011: 2ms 0100: 4ms 0101: 8ms 0110: 10ms 0111: 12ms 1000: 16ms 1001: 20ms 1010: 24ms 1011: 28ms 1100: 32ms 1101: 64ms 1110: 128ms 1111: 256ms</p> |
| 3:0 | AGC_ATTACK_TIME | 0000 | R/W | <p>This register controls the AGC attack time.</p> <p>0000: 0.5µs 0001: 1µs 0010: 2µs</p> |

| Addr: 0x16 | | AGC_ATTACK_RELEASE_TIME | | |
|------------|----------|-------------------------|--------|-----------------|
| Bit | Bit Name | Default | Access | Bit Description |
| | | | | 0011: 4µs |
| | | | | 0100: 8µs |
| | | | | 0101: 12µs |
| | | | | 0110: 16µs |
| | | | | 0111: 24µs |
| | | | | 1000: 32µs |
| | | | | 1001: 64µs |
| | | | | 1010: 128µs |
| | | | | 1011: 256µs |
| | | | | 1100: 512µs |
| | | | | 1101: 1000µs |
| | | | | 1110: 2000µs |
| | | | | 1111: 4000µs |

Figure 90:
AGC_HOLD Register Description

| Addr: 0x17 | | AGC_HOLD | | |
|------------|------------------|----------|--------|---|
| Bit | Bit Name | Default | Access | Bit Description |
| | | | | This register controls the timeout of the zero cross detection. |
| | | | | 0000: 0 (no timeout) |
| | | | | 0001: 20ms |
| | | | | 0010: 40ms |
| | | | | 0011: 80ms |
| | | | | 0100: 120ms |
| | | | | 0101: 160ms |
| 7:4 | ZERO_TIMEO UT | 0000 | R/W | 0110: 240ms |
| | | | | 0111: 320ms |
| | | | | 1000: 400ms |
| | | | | 1001: 480ms |
| | | | | 1010: 560ms |
| | | | | 1011: 640ms |
| | | | | 1100: 800ms |
| | | | | 1101: 960ms |
| | | | | 1110: 1120ms |
| | | | | 1111: 1280ms |
| 3:0 | HOLD_TIME | 0000 | R/W | This register controls the AGC hold time. |
| | | | | 0000: 0 (no hold time) |

| Addr: 0x17 | | AGC_HOLD | | |
|------------|----------|----------|--------|-----------------|
| Bit | Bit Name | Default | Access | Bit Description |
| | | | | 0001: 20ms |
| | | | | 0010: 40ms |
| | | | | 0011: 80ms |
| | | | | 0100: 120ms |
| | | | | 0101: 160ms |
| | | | | 0110: 240ms |
| | | | | 0111: 320ms |
| | | | | 1000: 400ms |
| | | | | 1001: 480ms |
| | | | | 1010: 560ms |
| | | | | 1011: 640ms |
| | | | | 1100: 800ms |
| | | | | 1101: 960ms |
| | | | | 1110: 1120ms |
| | | | | 1111: 1280ms |

Figure 91:
AGC_START_TIME Register Description

| Addr: 0x18 | | AGC_START_TIME | | |
|------------|--------------------------|----------------|--------|---|
| Bit | Bit Name | Default | Access | Bit Description |
| 2:0 | START_RAM P_TIME<2:0> | 000 | R/W | <p>This register controls the AGC gain ramp up step time only during startup of the device.</p> <p>000: 1ms/step</p> <p>001: 2ms/step</p> <p>010: 4ms/step</p> <p>011: 8ms/step</p> <p>100: 16ms/step</p> <p>101: 32ms/step</p> <p>110: 64ms/step</p> <p>111: 128ms/step</p> |

7.2.6 Operation Mode Control Register

Figure 92:
MODE_SWITCH_CONTROL Register Description

| Addr: 0x1A | | MODE_SWITCH_CONTROL | | |
|------------|-------------------|---------------------|--------|---|
| Bit | Bit Name | Default | Access | Bit Description |
| 6:5 | SHUTDOWN_DELAY | 00 | R/W | <p>This register controls the shutdown delay function of AS3418.</p> <p>00: 10ms(default after reset)</p> <p>01: 80ms</p> <p>10: 200ms</p> <p>11: 400ms</p> |
| 3:2 | MODE_SWITCH_DELAY | 11 | R/W | <p>Defines the time switching from ANC to PBO and PBO to MONITOR operation mode. During this mode switching delay the headphone amplifier multiplexer is not connected to any source.</p> <p>00: 5ms</p> <p>01: 100ms</p> <p>10: 200ms</p> <p>11: 400ms</p> |
| 1 | GAIN_JUMP_UP_EN | 0 | R/W | <p>This bit is independent of AGC_EN bit. The gain after a gain register write is not immediately set but is stepped up from old to new value if it is lower than the old gain setting. Gain change will follow AGC_RELEASE_TIME register setting.</p> <p>0: Gain Jump up disabled</p> <p>1: The gain is immediately set after a gain register write if it is higher than the old gain setting</p> |
| 0 | GAIN_JUMP_DOWN_EN | 0 | R/W | <p>This bit is independent of AGC_EN bit. The gain after a gain register write is not immediately set but is stepped down from old to new value if it's lower than the old gain setting. Gain change will follow AGC_ATTACK_TIME register setting.</p> <p>0: Gain Jump down disabled</p> <p>1: Gain jump down enabled</p> |

7.2.7 EEPROM Control Registers

Figure 93:
EEPROM_CONTROL Register Description

| Addr: 0x34 | | EEPROM_CONTROL | | |
|------------|--------------------|----------------|--------|--|
| Bit | Bit Name | Default | Access | Bit Description |
| 2 | EEPROM_UPLOAD_TEST | 0 | R/W | <p>The register bit supports an EEPROM upload test function which simulates an EEPROM write without executing the actual write in order to check if the supply voltage is high enough for proper EEPROM programming. Once the bit is set, the test is started automatically and cleared after the test is finished. The result, if the test was positive, can be read out in register EE_WR_TEST_OK.</p> <p>0: EEPROM upload test disabled 1: EEPROM upload test started</p> |
| 1 | EEPROM_UPLOAD | 0 | R/W | <p>This register triggers the EEPROM upload function which copies all register content of AS3418 to the AS3418 to store it permanently to the device. Once the upload is completed the bit is cleared automatically. The success of the EEPROM upload can be read out in register EE_READY.</p> <p>0: EEPROM upload function disabled 1: EEPROM upload function started</p> |
| 0 | EEPROM_DOWNLOAD | 0 | R/W | <p>This register triggers the EEPROM download function which copies all EEPROM content to the AS3418 configuration registers. Once the download is completed the bit is cleared automatically. The success of the EEPROM download can be read out in register EE_READY.</p> <p>0: EEPROM upload function disabled 1: EEPROM upload function started</p> |

Figure 95:
Slider Operation Mode – Application Example

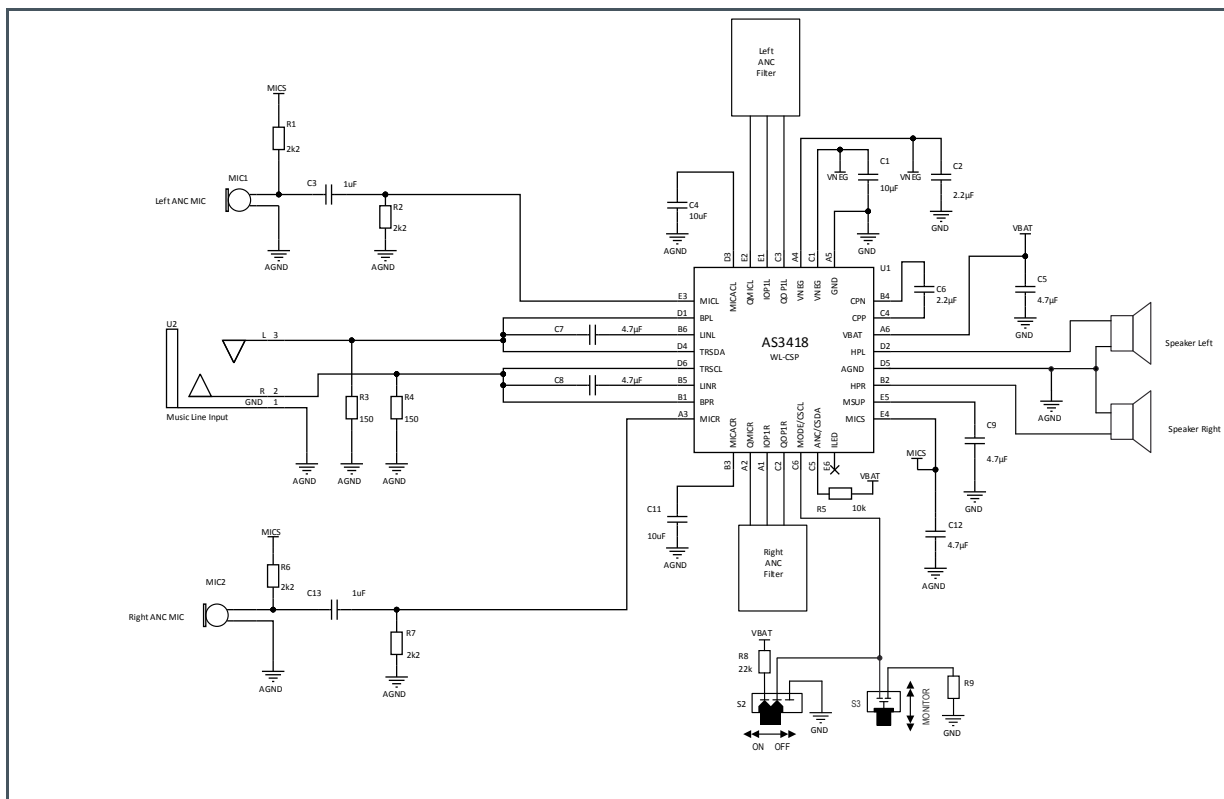
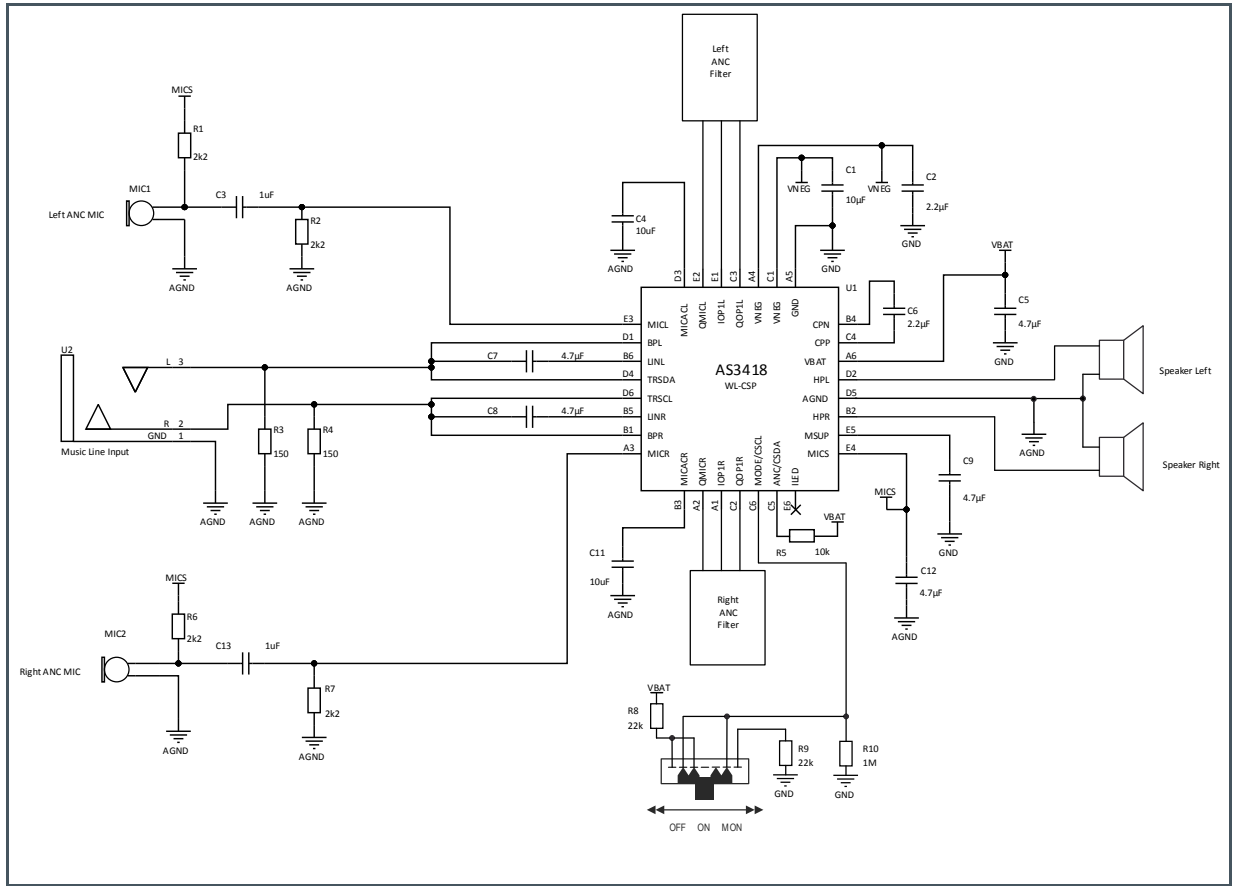

Figure 96 shows an application example of a Feed Forward ANC headset in Full Slider operation mode.

Figure 96:
Full Slider Operation Mode – Application Example



8.2 External Components

This chapter provides detailed information about recommended external components.

Figure 97:
Useful Caption

| Symbol | Parameter | Temp. Characteristic | Min. Rated Voltage | Max. Tolerance | Min. Nominal Capacitance / Resistance | Recommended typ. Component Value |
|-----------------------|-----------------------------------|----------------------|--------------------|----------------|---------------------------------------|----------------------------------|
| Capacitors | | | | | | |
| C_{VBAT} | Input Capacitor | Y5R; X5R | 4V | ±20% | 1.6μF | 4.7μF |
| C_{FLY} | VNEG charge pump flying capacitor | Y5R; X5R | 4V | ±20% | 0.97μF | 2.2μF |
| C_{ACR} , C_{ACL} | AC coupling capacitor | Y5R; X5R | 4V | ±10% | 5.6μF | 10μF |
| C_{VNEG} | Output Capacitor | Y5R; X5R | 4V | ±20% | 3.4μF | 10μF |

| Symbol | Parameter | Temp. Characteristic | Min. Rated Voltage | Max. Tolerance | Min. Nominal Capacitance / Resistance | Recommended typ. Component Value |
|---------------------------------------|---|----------------------|--------------------|----------------|---------------------------------------|----------------------------------|
| C _{MICS} | Output Capacitor microphone supply | Y5R; X5R | 4V | ±20% | 0.94µF | 4.7µF |
| C _{MSUP} | Output Capacitor microphone charge pump | Y5R; X5R | | ±20% | 0.94µF | 4.7µF |
| C _{MICL} , C _{MICR} | AC coupling capacitor; value depends on ANC filter design | Y5R; X5R | | ±10% | - | - |
| C _{FILTER} | ANC filter related capacitors | Y5R; X5R | | ±10% | - | - |

9 Package Drawings & Markings

Figure 98:
WL-CSP Package Outline Drawing

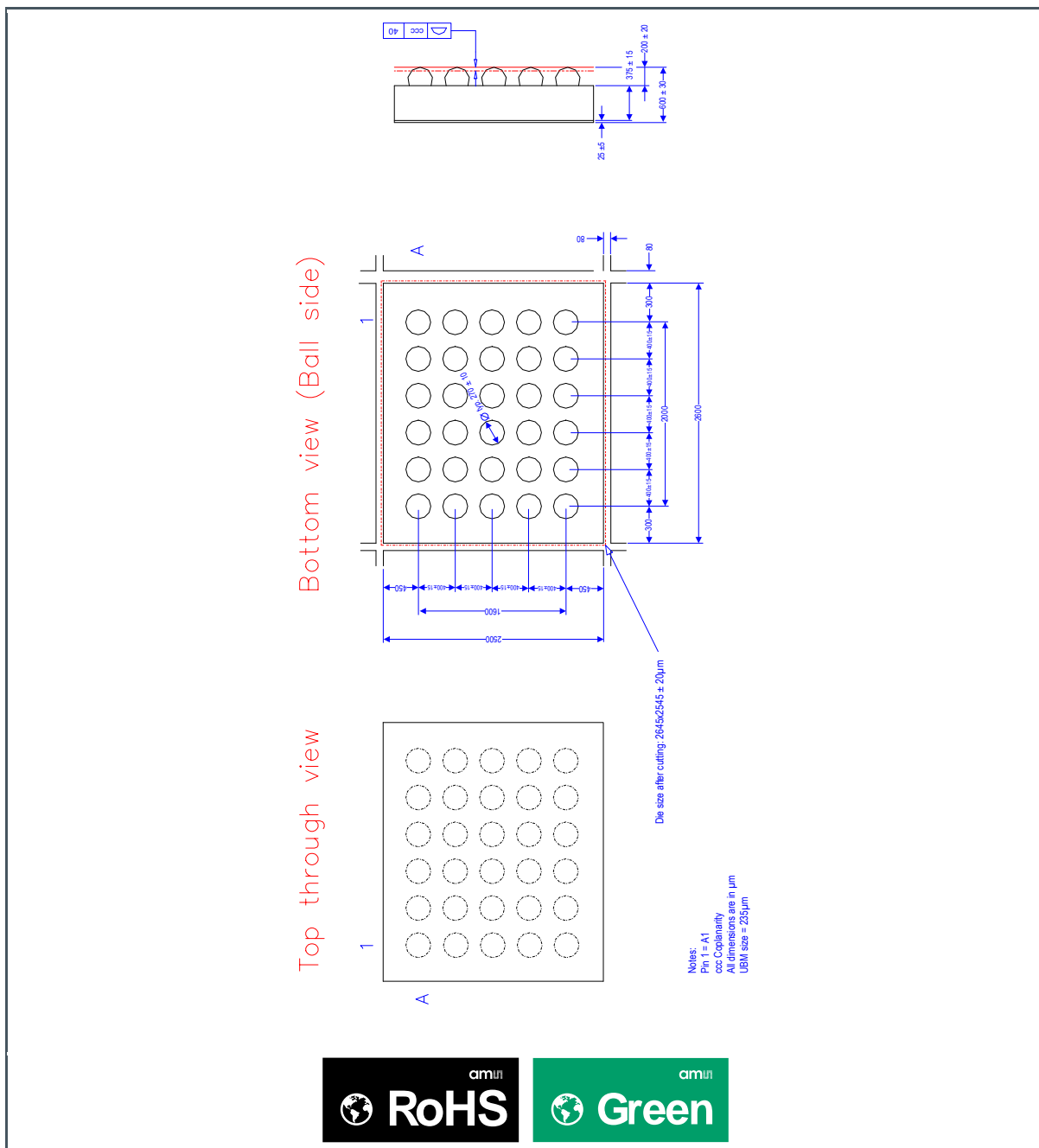

- (1) All dimensions are in μm . Angles in degrees.
- (2) Dimensioning and tolerancing conform to ASME Y14.5M-1994.
- (3) This package contains no lead (Pb).
- (4) This drawing is subject to change without notice.

Figure 99:
Package Marking/Code

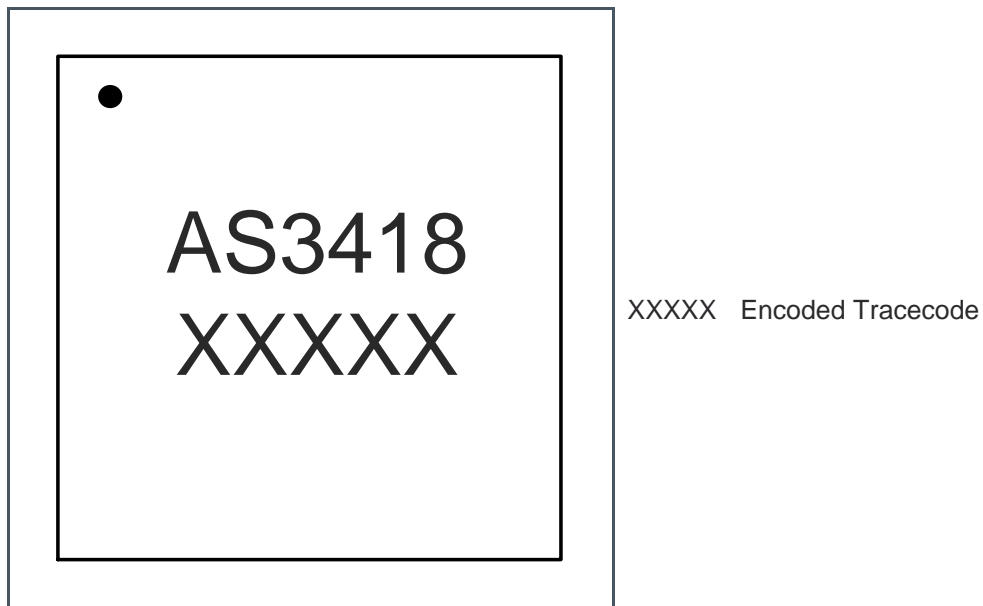

10 Revision Information

| Document Status | Product Status | Definition |
|--------------------------|-----------------|--|
| Product Preview | Pre-Development | Information in this datasheet is based on product ideas in the planning phase of development. All specifications are design goals without any warranty and are subject to change without notice |
| Preliminary Datasheet | Pre-Production | Information in this datasheet is based on products in the design, validation or qualification phase of development. The performance and parameters shown in this document are preliminary without any warranty and are subject to change without notice |
| Datasheet | Production | Information in this datasheet is based on products in ramp-up to full production or full production which conform to specifications in accordance with the terms of ams AG standard warranty as given in the General Terms of Trade |
| Datasheet (discontinued) | Discontinued | Information in this datasheet is based on products which conform to specifications in accordance with the terms of ams AG standard warranty as given in the General Terms of Trade, but these products have been superseded and should not be used for new designs |

| Changes from previous version to current revision v4-00 | Page |
|---|------|
| Figure 94 update of ball number of pin QOP1L | 70 |
| Figure 95 update of ball number of pin QOP1L | 71 |
| Figure 96 update of ball number of pin QOP1L | 72 |
| | |
| | |
| | |
| | |

- Page and figure numbers for the previous version may differ from page and figure numbers in the current revision.
- Correction of typographical errors is not explicitly mentioned.

11 Legal Information

Copyrights & Disclaimer

Copyright ams AG, Tobelbader Strasse 30, 8141 Premstaetten, Austria-Europe. Trademarks Registered. All rights reserved. The material herein may not be reproduced, adapted, merged, translated, stored, or used without the prior written consent of the copyright owner.

Devices sold by ams AG are covered by the warranty and patent indemnification provisions appearing in its General Terms of Trade. ams AG makes no warranty, express, statutory, implied, or by description regarding the information set forth herein. ams AG reserves the right to change specifications and prices at any time and without notice. Therefore, prior to designing this product into a system, it is necessary to check with ams AG for current information. This product is intended for use in commercial applications. Applications requiring extended temperature range, unusual environmental requirements, or high reliability applications, such as military, medical life-support or life-sustaining equipment are specifically not recommended without additional processing by ams AG for each application. This product is provided by ams AG "AS IS" and any express or implied warranties, including, but not limited to the implied warranties of merchantability and fitness for a particular purpose are disclaimed.

ams AG shall not be liable to recipient or any third party for any damages, including but not limited to personal injury, property damage, loss of profits, loss of use, interruption of business or indirect, special, incidental or consequential damages, of any kind, in connection with or arising out of the furnishing, performance or use of the technical data herein. No obligation or liability to recipient or any third party shall arise or flow out of ams AG rendering of technical or other services.

RoHS Compliant & ams Green Statement

RoHS Compliant: The term RoHS compliant means that ams AG products fully comply with current RoHS directives. Our semiconductor products do not contain any chemicals for all 6 substance categories plus additional 4 substance categories (per amendment EU 2015/863), including the requirement that lead not exceed 0.1% by weight in homogeneous materials. Where designed to be soldered at high temperatures, RoHS compliant products are suitable for use in specified lead-free processes.

ams Green (RoHS compliant and no Sb/Br/Cl): ams Green defines that in addition to RoHS compliance, our products are free of Bromine (Br) and Antimony (Sb) based flame retardants (Br or Sb do not exceed 0.1% by weight in homogeneous material) and do not contain Chlorine (Cl not exceed 0.1% by weight in homogeneous material).

Important Information: The information provided in this statement represents ams AG knowledge and belief as of the date that it is provided. ams AG bases its knowledge and belief on information provided by third parties, and makes no representation or warranty as to the accuracy of such information. Efforts are underway to better integrate information from third parties. ams AG has taken and continues to take reasonable steps to provide representative and accurate information but may not have conducted destructive testing or chemical analysis on incoming materials and chemicals. ams AG and ams AG suppliers consider certain information to be proprietary, and thus CAS numbers and other limited information may not be available for release.

Headquarters

ams AG
Tobelbader Strasse 30
8141 Premstaetten
Austria, Europe
Tel: +43 (0) 3136 500 0

Please visit our website at www.ams.com

Buy our products or get free samples online at www.ams.com/Products

Technical Support is available at www.ams.com/Technical-Support



Provide feedback about this document at www.ams.com/Document-Feedback

For sales offices, distributors and representatives go to www.ams.com/Contact

For further information and requests, e-mail us at ams_sales@ams.com

Looking for pricing, stock, or lifecycle information?

Click below to explore more details on WIN SOURCE:

-  View [AS3418-EWLM](#) on WIN SOURCE
-  [ams](#) Information

Optimize Your Supply Chain with WIN SOURCE Solutions

-  Global Sourcing Solution
-  Obsolete Management
-  Cost Control Management
-  Shortage Management
-  Alternative Solution
-  Excess Inventory Management