



**THE DATASHEET OF  
RB751V-40-HF**



## RB751V-40-HF

**$I_o = 30 \text{ mA}$**   
 **$V_R = 30 \text{ Volts}$**   
**RoHS Device**  
**Halogen Free**

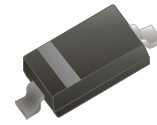

### Features

- Low current rectifier.
- Low voltage, low inductance.
- For power supply.

### Mechanical data

- Case: SOD-323, Standard package, molded plastic.
- Terminals: Solderable per MIL-STD-750, method 2026.
- Mounting position: Any.
- Weight: 0.01 grams(approx.).

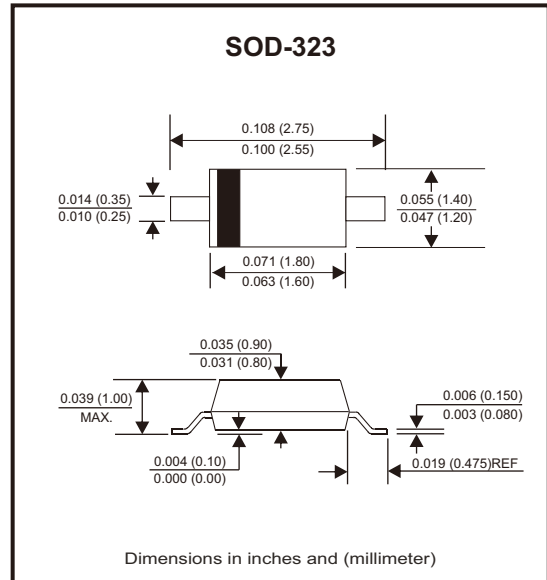

### Circuit Diagram



### Maximum Ratings (at Ta=25°C unless otherwise noted)

Parameter	Conditions	Symbol	Limit	Unit
Peak reverse voltage		$V_{RM}$	40	V
DC reverse voltage		$V_R$	30	V
Mean rectifying current		$I_o$	30	mA
Non-repetitive peak forward surge current	8.3ms single half sine-wave superimposed on rate load (JEDEC method)	$I_{FSM}$	0.2	A
Power dissipation		$P_D$	200	mW
Thermal resistance	Junction to ambient	$R_{\theta JA}$	500	°C/W
Junction temperature range		$T_J$	-40 ~ +125	°C
Storage temperature range		$T_{STG}$	-55 ~ +150	°C

### Electrical Characteristics (at Ta=25°C unless otherwise noted)

Parameter	Conditions	Symbol	Min.	Typ.	Max.	Unit
Forward voltage	$I_F = 1 \text{ mA}$	$V_F$			0.37	V
Reverse current	$V_R = 30 \text{ V}$	$I_R$			0.50	μA
Capacitance between terminals	$V_R = 1 \text{ V}, f = 1 \text{ MHz}$	$C_T$		2		pF

## Rating and Characteristic Curves (RB751V-40-HF)

Fig.1 - Power Derating Curve

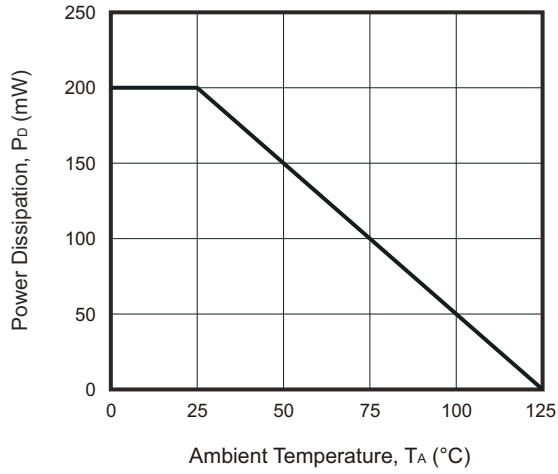

Fig.2 - Capacitance Characteristics

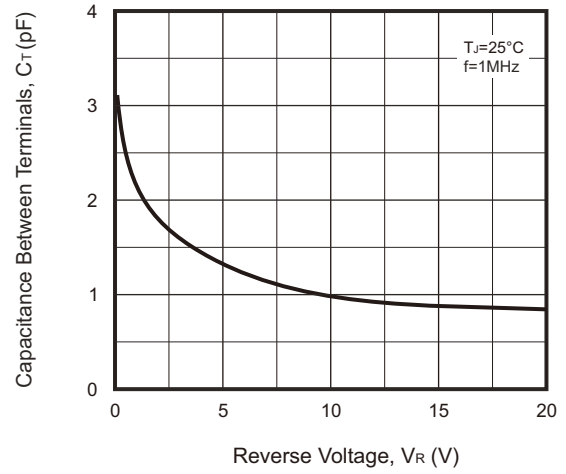

Fig.3 - Forward Characteristics

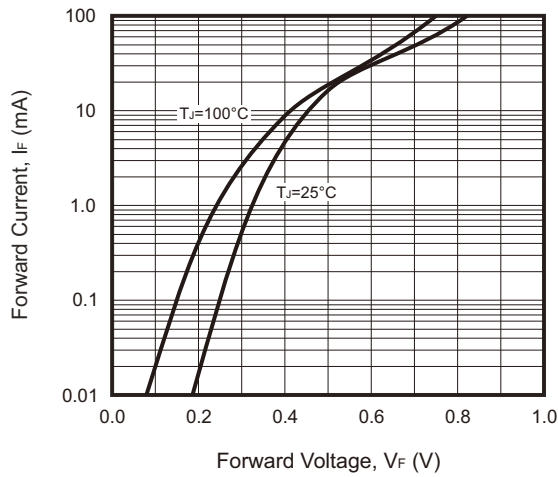
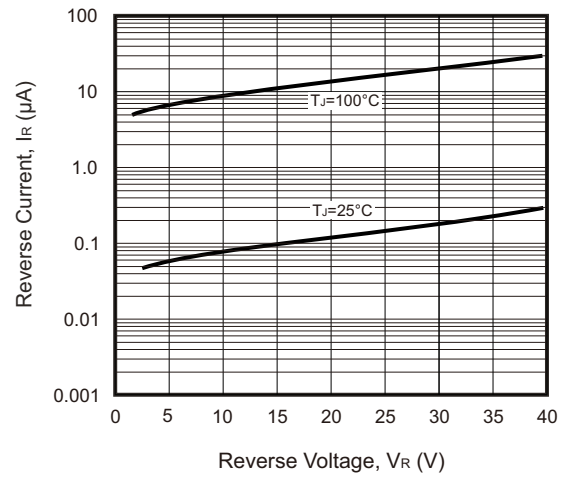
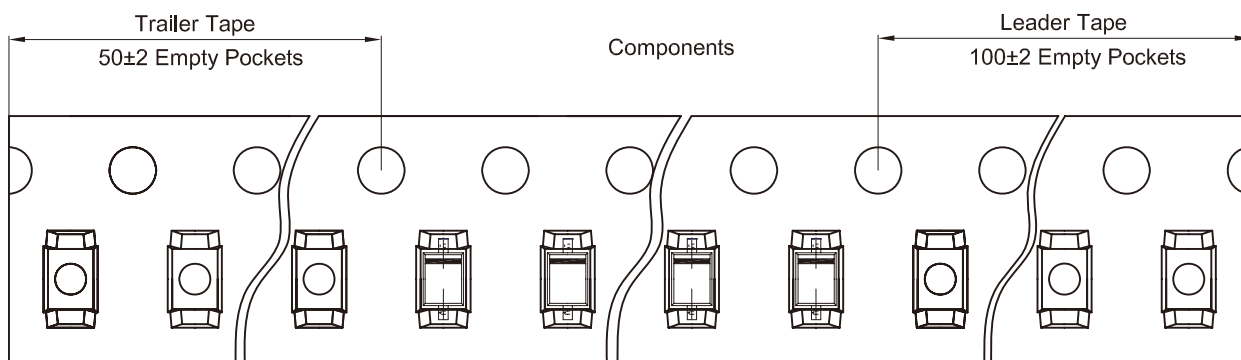
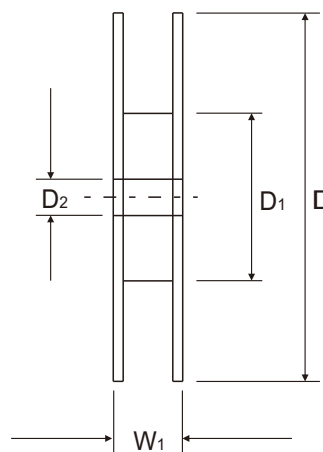
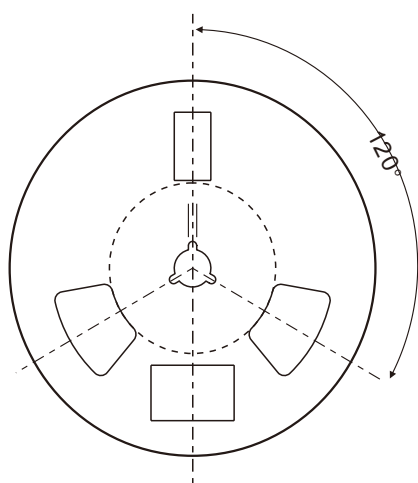
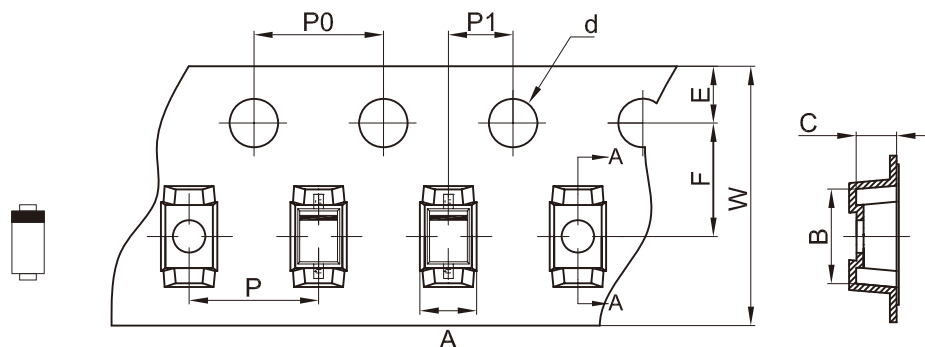

Fig.4 - Reverse Characteristics



## Reel Taping Specification



SOD-323	SYMBOL	A	B	C	d	D	D1	D2
	(mm)	1.48 ± 0.05	3.30 ± 0.05	1.25 ± 0.05	1.50 ± 0.10	178.00 ± 2.00	54.40 ± 1.00	13.00 ± 1.00
	(inch)	0.058 ± 0.002	0.130 ± 0.002	0.049 ± 0.002	0.059 ± 0.004	7.008 ± 0.079	2.142 ± 0.039	0.512 ± 0.039

SOD-323	SYMBOL	E	F	P	P0	P1	W	W1
	(mm)	1.75 ± 0.10	3.50 ± 0.10	4.00 ± 0.10	4.00 ± 0.10	2.00 ± 0.10	8.00 + 0.30 / - 0.10	12.30 ± 1.00
	(inch)	0.069 ± 0.004	0.138 ± 0.004	0.158 ± 0.004	0.158 ± 0.004	0.079 ± 0.004	0.315 + 0.012 / - 0.004	0.484 ± 0.039

Company reserves the right to improve product design, functions and reliability without notice.

REV:B

## Marking Code

Part Number	Marking Code
RB751V-40-HF	5



■ = Cathode band

Solid dot = Control code

## Suggested P.C.B. PAD Layout

SIZE	SOD-323	
	(mm)	(inch)
A	2.15	0.085
B	0.70	0.028
C	0.70	0.028

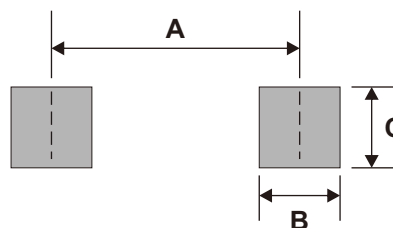



Note: 1.General tolerance:  $\pm 0.05\text{mm}$ .  
2.The pad layout is for reference purposes only.

## Standard Packaging

Case Type	REEL PACK	
	REEL ( pcs )	Reel Size (inch)
SOD-323	3,000	7

## Looking for pricing, stock, or lifecycle information?

Click below to explore more details on WIN SOURCE:

-  [View RB751V-40-HF on WIN SOURCE](#)
-  [Comchip Technology Information](#)

## Optimize Your Supply Chain with WIN SOURCE Solutions

-  Global Sourcing Solution
-  Obsolete Management
-  Cost Control Management
-  Shortage Management
-  Alternative Solution
-  Excess Inventory Management