



**THE DATASHEET OF
ASPI-0504-102M-T**





FEATURES:

- Suitable for RoHS reflow profile
- High current rating and low DCR
- Special lead wire design to prevent open circuit failure
- Excellent terminal strength to mechanical stress

APPLICATIONS:

- OA equipments
- PC and notebook
- LCD TV set
- Power supply

ELECTRICAL SPECIFICATIONS:

Abracon P/N:	ASPI-0504 Series
Operating Temperature:	-40°C to +85°C
Storage Temperature:	+5°C to +40°C (In Tape and Reel)

PART NUMBER ASPI-0504- Inductance Code	Inductance (uH)	Test Frequency	Tolerance	DCR (Ω) max	IDC (A) max
ASPI-0504-4R7	4.7	7.96MHz	K, M	0.04	3.50
ASPI-0504-100	10	2.52MHz	K, M	0.10	1.44
ASPI-0504-120	12	2.52MHz	K, M	0.12	1.40
ASPI-0504-150	15	2.52MHz	K, M	0.14	1.30
ASPI-0504-180	18	2.52MHz	K, M	0.15	1.23
ASPI-0504-220	22	2.52MHz	K, M	0.18	1.11
ASPI-0504-270	27	2.52MHz	K, M	0.20	0.97
ASPI-0504-330	33	2.52MHz	K, M	0.23	0.88
ASPI-0504-390	39	2.52MHz	K, M	0.32	0.80
ASPI-0504-470	47	2.52MHz	K, M	0.37	0.72
ASPI-0504-560	56	2.52MHz	K	0.42	0.68
ASPI-0504-680	68	2.52MHz	K	0.46	0.61
ASPI-0504-820	82	2.52MHz	K	0.60	0.58
ASPI-0504-101	100	1KHz	K	0.70	0.52
ASPI-0504-121	120	1KHz	K	0.93	0.48
ASPI-0504-151	150	1KHz	K	1.10	0.40
ASPI-0504-181	180	1KHz	K	1.38	0.38
ASPI-0504-221	220	1KHz	K	1.57	0.35
ASPI-0504-102	1000	1KHz	M	14.4	0.15

Test Conditions

Inductance: 100kHz

Isat: $\Delta L/L$ (initial) \geq -10% or $\Delta T=40^\circ\text{C}$ ($T_a=20^\circ\text{C}$), whichever is lower.

OPTIONS AND PART IDENTIFICATION

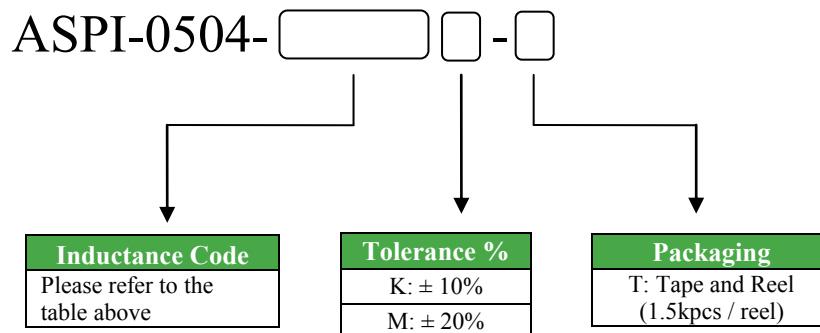



OUTLINE DRAWING:

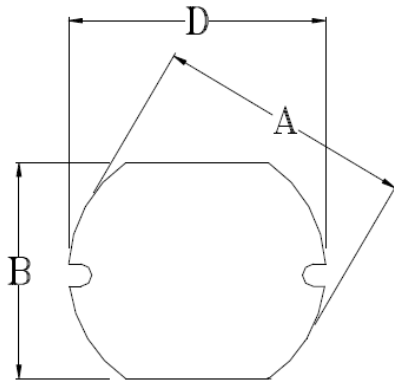

A	B	C	D	E	F	G
5.8±0.3	5.2±0.3	4.5±0.35	5.8±0.3	1.80	1.90	5.00

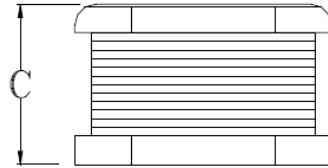

Recommended Land Pattern

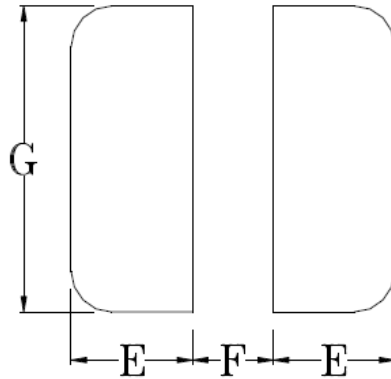
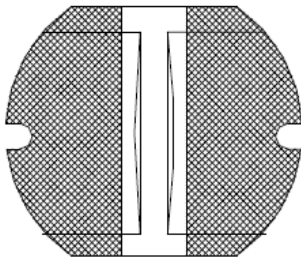

Dimension: mm

REFLOW PROFILE:

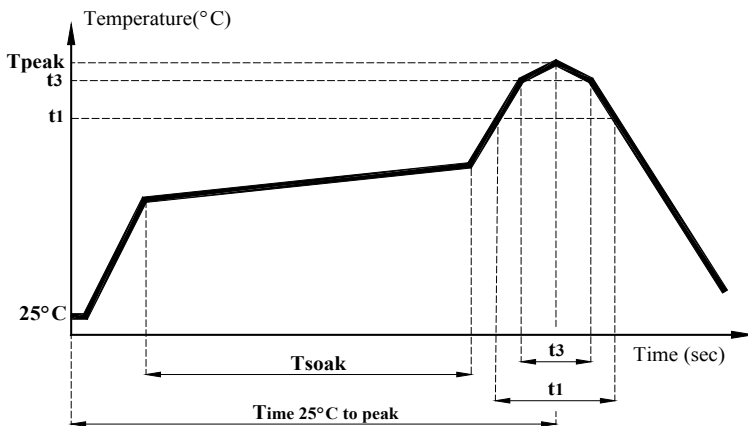

Item	mark	
Temperature rise gradient		3°C/sec (max)
Heating time	Tsoak	50s ~ 150s
Heating temperature		120°C~180°C
Time over 217°C	t1	70 sec
Time within 5°C of actual peak temperature	t3	10~30 sec
Peak temperature	Tpeak	250 (+0 / -5 °C)
Time 25°C to peak Temperature		6 minutes max.



TAPE & REEL:

T: 1,500pcs / reel

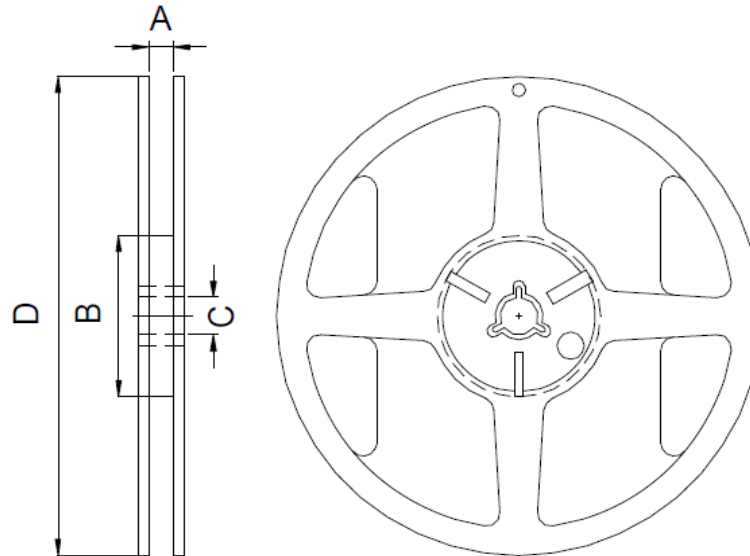
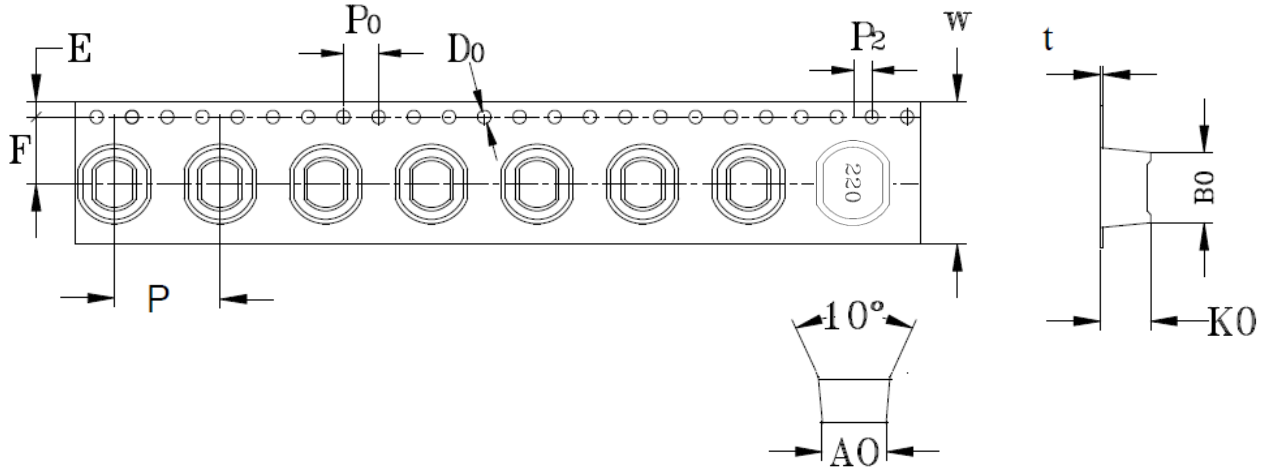



A	B	C	D
12.5 ± 0.2	100 ± 0.5	13.2 ± 0.3	330 ± 1.0

Dimension: mm

ATTENTION Abracon Corporation's products are COTS – Commercial-Off-The-Shelf products; suitable for Commercial, Industrial and, where designated, Automotive Applications. Abracon's products are not specifically designed for Military, Aviation, Aerospace, Life-dependant Medical applications or any application requiring high reliability where component failure could result in loss of life and/or property. For applications requiring high reliability and/or presenting an extreme operating environment, written consent and authorization from Abracon Corporation is required. Please contact Abracon Corporation for more information.

Looking for pricing, stock, or lifecycle information?

Click below to explore more details on WIN SOURCE:

-  [View ASPI-0504-102M-T on WIN SOURCE](#)
-  [Abracon LLC Information](#)

Optimize Your Supply Chain with WIN SOURCE Solutions

-  Global Sourcing Solution
-  Obsolete Management
-  Cost Control Management
-  Shortage Management
-  Alternative Solution
-  Excess Inventory Management