



**THE DATASHEET OF  
NLHV4157NDFT2G**



# Negative Voltage SPDT Switch

## NLHV4157N

The NLHV4157N is an advanced CMOS analog switch fabricated with silicon gate CMOS technology. The device passes analog and digital negative voltages that may vary across the full power-supply range (from  $V_{EE}$  to GND).

### Features

- Operating Voltage Range:  $V_{EE} = -12\text{ V to } -4\text{ V}$
- Switch Signal Voltage Range:  $V_{IS} = V_{EE}\text{ to GND}$
- Positive Control Signal Voltage:  $V_{IN} = 0\text{ to } 3.3\text{ V}$
- Low ON Resistance:  $R_{ON} \leq 5\ \Omega @ V_{EE} = -10\text{ V}$
- Latch-up Performance Exceeds 200 mA
- Available in: SC-88 6-Pin Package
- These Devices are Pb-Free, Halogen-Free/BFR-Free and are RoHS-Compliant

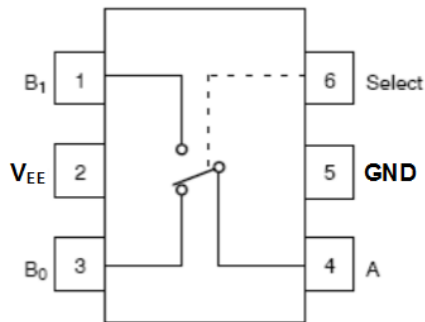
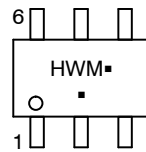

Figure 1. Pin Assignment and logic Diagram



SC-88  
DF SUFFIX  
CASE 419B

### MARKING DIAGRAM



SC-88  
DF SUFFIX  
CASE 419AD

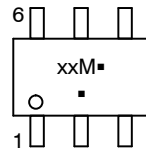

HW/xx = Device Code  
M = Date Code\*  
▪ = Pb-Free Package

(Note: Microdot may be in either location)

\*Date Code orientation and/or position may vary depending upon manufacturing location.

### FUNCTION TABLE

Select Input	Function
L	B0 Connected to A
H	B1 Connected to A

### ORDERING INFORMATION

See detailed ordering and shipping information on page 2 of this data sheet.

# NLHV4157N

## ORDERING INFORMATION

Device	Marking	Package	Case Code	Shipping†
NLHV4157NDFT2G	HW	SC-88	419B	3000 / Tape & Reel
NLHV4157NSDFT2G (In Development, please contact <b>onsemi</b> )	XX	SC-88	419AD	3000 / Tape & Reel

†For information on tape and reel specifications, including part orientation and tape sizes, please refer to our Tape and Reel Packaging Specifications Brochure, BRD8011/D.

## MAXIMUM RATINGS

Symbol	Rating	Value	Unit
$V_{EE}$	DC Supply Voltage	-13 to +0.5	V
$V_{IS}$	Analog Input Voltage (Note 1)	$V_{EE}-0.5$ to +0.5	V
$V_{IN}$	Digital Select Input Voltage (Note 1)	-0.5 to +3.6	V
$I_{IOK}$	Switch Input/Output diode current	±50	mA
$I_{IK}$	Select input diode current	-50	mA
$P_D$	Power Dissipation in Still Air	60	mW
$T_L$	Lead Temperature, 1 mm from Case for 10 seconds	260	°C
$T_J$	Junction Bias Under Bias	150	°C
MSL	Moisture Sensitivity	Level 1	
$F_R$	Flammability Rating	Oxygen Index: 30% – 35% UL94-V0 (0.125 in)	°C
$I_L$	Latch-up Current (Note1) Below GND and above $V_{EE}$ at 125°C Below GND and above $V_{EE}$ at 25°C	±200	mA
		±300	
$T_s$	Storage Temperature	-65 to +150	°C
$\theta_{JA}$	Thermal Resistance	400	°C/W
ESD	ESD Protection	Human Body Model	V
		Machine Model	

Stresses exceeding those listed in the Maximum Ratings table may damage the device. If any of these limits are exceeded, device functionality should not be assumed, damage may occur and reliability may be affected.

1. The input and output voltage ratings may be exceeded if the input and output diode current ratings are observed.

## RECOMMENDED OPERATING CONDITIONS (Note 2)

Symbol	Parameter	Min	Max	Unit
$V_{EE}$	DC Supply Voltage	-12	-4	V
$V_S$	Switch Input / Output Voltage (B0, B1, A)	$V_{EE}$	GND	V
$V_{IN}$	Digital Select Input Voltage	GND	3.3	V
$T_A$	Operating Temperature Range	-55	+125	°C
$t_r, t_f$	Input Transition Rise or Fall Time (Select Input)	0	100	ns/V

Functional operation above the stresses listed in the Recommended Operating Ranges is not implied. Extended exposure to stresses beyond the Recommended Operating Ranges limits may affect device reliability.

2. Select input must be held HIGH or LOW, it must not float.

# NLHV4157N

## DC ELECTRICAL CHARACTERISTICS (Voltages referenced to GND; Typical characteristics are $T_A$ at 25°C.)

Symbol	Parameter	Condition	$V_{EE}$ , V	-55° to 125°C			Unit
				Min	Typ	Max	
<b>SELECT INPUT</b>							
$V_{IH}$	Minimum High-Level Input Voltage		-12	1.8		3.3	V
			-10	1.6		3.3	
			-8	1.4		3.3	
			-6	1.2		3.3	
			-4	1.0		3.3	
$V_{IL}$	Maximum Low-Level Input Voltage		-12	0		0.8	V
			-10	0		0.7	
			-8	0		0.6	
			-6	0		0.5	
			-4	0		0.4	
$I_{IN}$	Maximum Input Leakage Current	$V_{IN} = 3.3\text{ V or GND}$	-10		±0.2	±50	µA
		$V_{IN} = 3.3\text{ V or GND, test at 25°C only}$	-10			±0.5	
<b>POWER SUPPLY</b>							
$I_{CC}$	Maximum Quiescent Supply Current	Select = 3.3 V or GND, $V_{IS} = V_{EE}$ or GND	-10 to -4		25	80	µA
<b>ANALOG SWITCH</b>							
$R_{ON}$	Maximum ON Resistance (Note 3)	$V_{IN} = V_{IL}$ or $V_{IH}$ $V_{IS} = V_{EE}$ to GND $I_O \leq 10\text{ mA}$	-12		2.6	4.5	Ω
			-10		3.0	5	
			-8		3.5	5.8	
			-6		4.5	7.5	
		-4		9	15		
$R_{FLAT}$	ON Resistance Flatness (Notes 3, 4, 6)	$V_{IN} = V_{IL}$ or $V_{IH}$ $V_{IS} = V_{EE}$ to GND $I_O \leq 10\text{ mA}$	-12		0.4		Ω
			-10		1.2		
			-8		1.7		
			-6		2.5		
		-4		6			
$\Delta R_{ON}$	$R_{ON}$ Mismatch Between (Notes 3, 4, 5)	$I_A = -10\text{ mA, } V_{Bn} = -8.4\text{ V}$	-12		0.2		Ω
		$I_A = -10\text{ mA, } V_{Bn} = -7\text{ V}$	-10		0.2		
		$I_A = -10\text{ mA, } V_{Bn} = -5.6\text{ V}$	-8		0.25		
		$I_A = -10\text{ mA, } V_{Bn} = -4.2\text{ V}$	-6		0.25		
		$I_A = -5\text{ mA, } V_{Bn} = -2.8\text{ V}$	-4		0.3		
$I_{NC(OFF)}, I_{NO(OFF)}$	NC or NO OFF Leakage Current (Figure 9)	$V_{IN} = V_{IL}$ or $V_{IH}, V_{Bn} = \text{GND, } V_A = V_{EE}$ to GND	-10		±1.0	±20	µA
$I_{COM(ON)}$	COM ON Leakage Current (Figure 9)	$V_{IN} = V_{IL}$ or $V_{IH}; V_A = \text{GND V or } V_{EE}; V_{B1} = \text{GND or } V_{EE}$ with $V_{B0}$ floating, or $V_{B0} = \text{GND or } V_{EE}$ with $V_{B1}$ floating	-10		±2.0	±20	µA

Product parametric performance is indicated in the Electrical Characteristics for the listed test conditions, unless otherwise noted. Product performance may not be indicated by the Electrical Characteristics if operated under different conditions.

3. Measured by the voltage drop between A and B pins at the indicated current through the switch. On Resistance is determined by the lower of the voltages on the two (A or B Ports).
4. Parameter is characterized but not tested in production.
5.  $\Delta R_{ON} = R_{ONmax} - R_{ONmin}$  measured at identical  $V_{EE}$ , temperature and voltage levels.
6. Flatness is defined as the difference between the maximum and minimum value of ON Resistance over the specified range of conditions.

# NLHV4157N

## AC ELECTRICAL CHARACTERISTICS (Voltages referenced to GND; Typical characteristics are $T_A$ at 25°C.)

Symbol	Parameter	Condition	$V_{EE}$ , V	-55° to 125°C			Unit
				Min	Typ	Max	
$t_{PHL}$ , $t_{PLH}$	Propagation Delay, Bus to Bus (Note 8) (A to B <sub>n</sub> )	$C_L = 100$ pF (Figures 2, 3)	-12 to -4			2	ns
$t_{PZL}$ , $t_{PZH}$	Switch Enable Time Turn-On Time (A to B <sub>n</sub> )	$C_L = 100$ pF (Figures 2, 3)	-12			220	ns
			-10			175	
			-8			165	
			-6			165	
			-4			200	
$t_{PLZ}$ , $t_{PHZ}$	Switch Disable Time Turn-Off Time (A to B <sub>n</sub> )	$C_L = 100$ pF (Figures 2, 3)	-12			225	ns
			-10			155	
			-8			150	
			-6			120	
			-4			145	
$t_B$	Switch Break Time	$R_L = 50$ $\Omega$ , $C_L = 100$ pF, $V_{IS} = -2.5$ V (Figure 4)	-12	5		60	ns
			-10	5		60	
			-8	10		75	
			-6	10		90	
			-4	40		135	
$t_{POR}$	Power ON Reset Time	Measured from $V_{EE} = -4$ V	-12 to -4			20	$\mu$ s
Q	Charge Injection (Note 7)	$C_L = 1$ nF, $V_{GEN} = 0$ V, $R_{GEN} = 0$ $\Omega$ (Figure 5)	-12			170	pC
			-10			120	
			-8			95	
			-6			55	
			-4			40	
OIRR	Off-Isolation (Note 9)	$R_L = 50$ $\Omega$ , $f = 10$ MHz (Figure 6)	-12 to -4		-33		dB
Xtalk	Crosstalk	$R_L = 50$ $\Omega$ , $f = 10$ MHz (Figure 7)	-12 to -4		-42		dB
BW	-3 dB Bandwidth	$R_L = 50$ $\Omega$ (Figure 10)	-12 to -4		200		MHz

7. Guaranteed by Design.

8. This parameter is guaranteed by design but not tested. The bus switch contributes no propagation delay other than the RC delay of the ON Resistance of the switch and the 50 pF load capacitance, when driven by an ideal voltage source (zero output impedance).

9. Off Isolation =  $20 \log_{10} [V_A/V_{Bn}]$ .

## CAPACITANCES (Note 10)

Symbol	Parameter	Test Conditions	Typical @ 25°C	Unit
$C_{IN}$	Input Capacitance, Select Inputs	$V_{EE} = -12$ V	6	pF
$C_{IOB}$	B-Port OFF Capacitance	$V_{EE} = -10$ V	45	pF
$C_{IOA\_ON}$	A Port Capacitance when Switch is Enabled	$V_{EE} = -10$ V	100	pF

10.  $T_A = +25^\circ\text{C}$ ,  $f = 1$  MHz, Capacitance is characterized but not tested in production.

# NLHV4157N

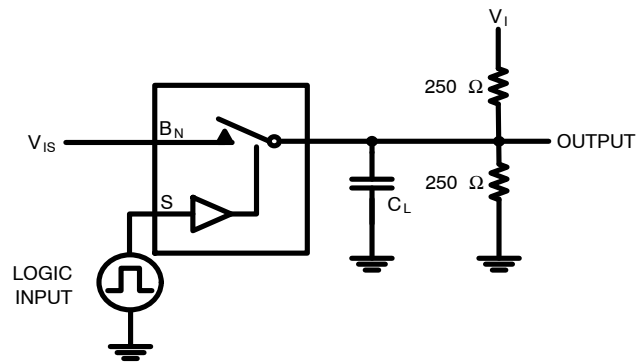

Note: Input  $V_{IS}$  driven by  $50 \Omega$  source terminated by  $50 \Omega$ .

Note:  $C_L$  includes load and stray capacitance.

Input PRR = 100 kHz,  $t_W = 5 \mu s$ .

Parameter	$V_I$	$V_{IS}$
$t_{PLH} / t_{PHL}$	Open	Source
$t_{PZL} / t_{PLZ}$	GND	$V_{EE}$
$t_{PZH} / t_{PHZ}$	$2 \times V_{EE}$	GND

Figure 2. AC Test Circuit

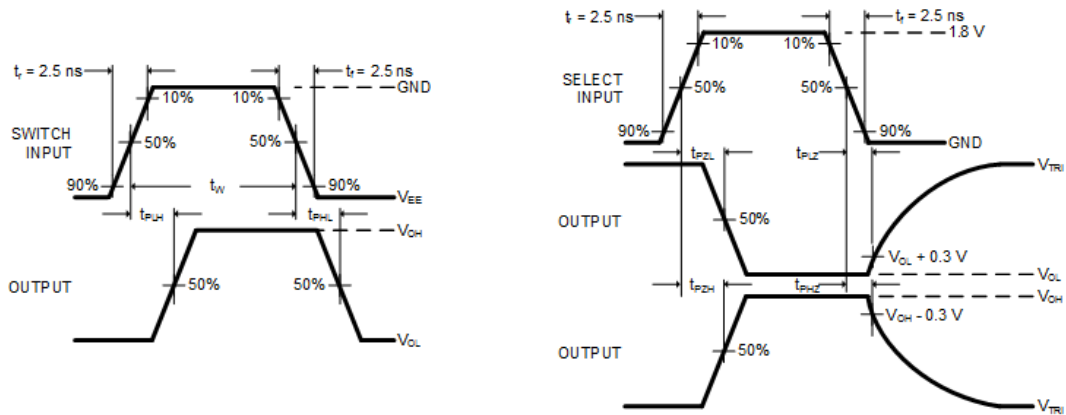

Figure 3. AC Test Waveforms

# NLHV4157N

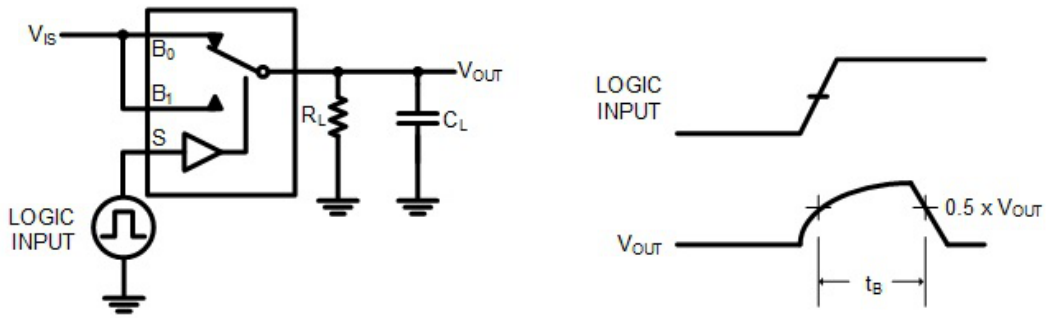

Figure 4. Switch Break Interval Timing

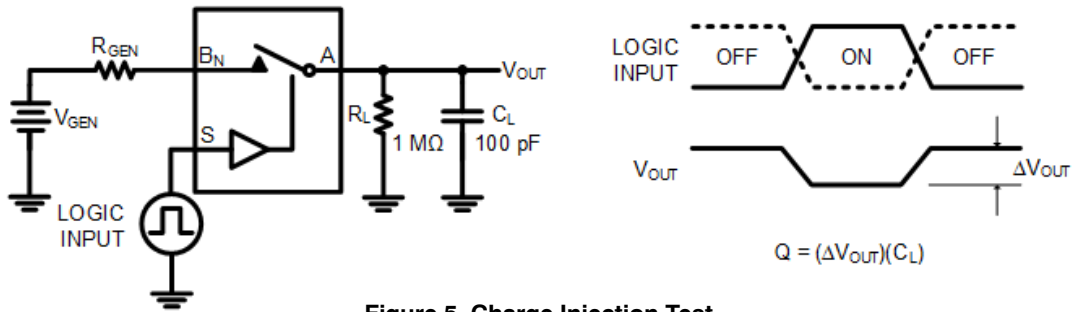

Figure 5. Charge Injection Test

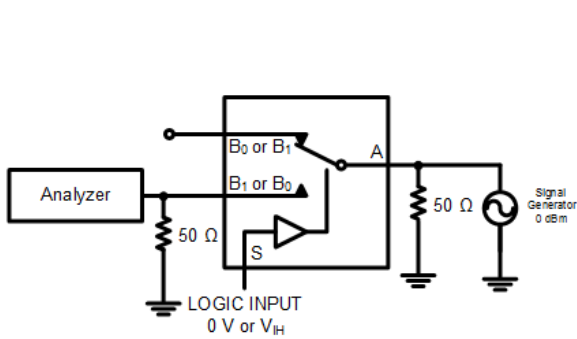

Figure 6. Off Isolation

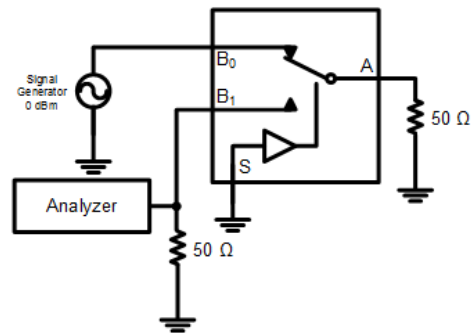

Figure 7. Crosstalk

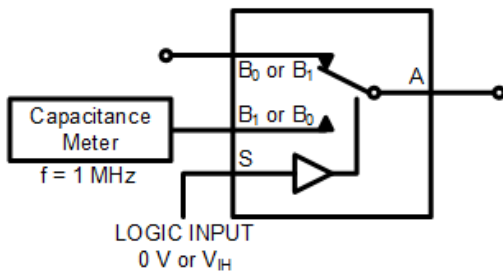

Figure 8. Channel Off Capacitance

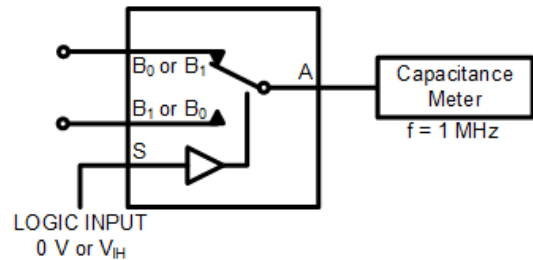
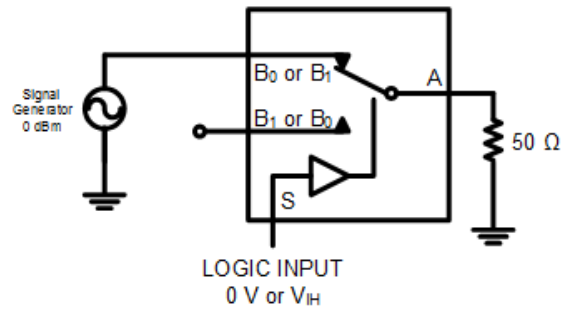

Figure 9. Channel On Capacitance

# NLHV4157N



$$BW = \frac{0.707 \cdot VA}{VBn}, \quad n = 0 \text{ or } 1$$

Figure 10. Bandwidth

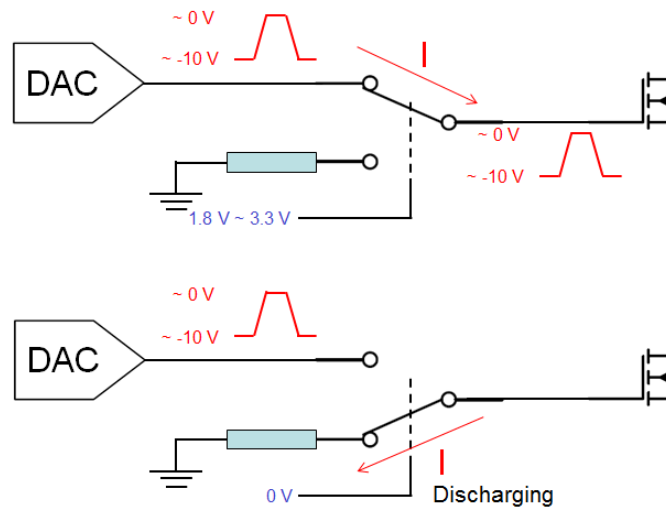
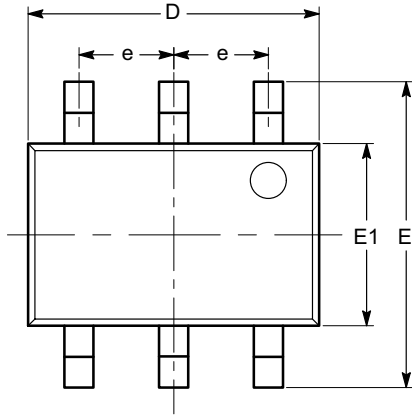

Figure 11. Typical Application

# NLHV4157N

## PACKAGE DIMENSIONS

SC-88 (SC-70 6 Lead), 1.25x2  
CASE 419AD  
ISSUE A



SYMBOL	MIN	NOM	MAX
A	0.80		1.10
A1	0.00		0.10
A2	0.80		1.00
b	0.15		0.30
c	0.10		0.18
D	1.80	2.00	2.20
E	1.80	2.10	2.40
E1	1.15	1.25	1.35
e	0.65 BSC		
L	0.26	0.36	0.46
L1	0.42 REF		
L2	0.15 BSC		
$\theta$	0°		8°
$\theta_1$	4°		10°

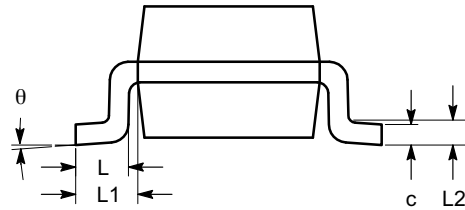
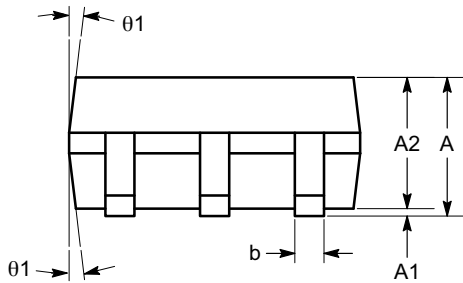

**Notes:**

- (1) All dimensions are in millimeters. Angles in degrees.
- (2) Complies with JEDEC MO-203.

# MECHANICAL CASE OUTLINE PACKAGE DIMENSIONS



**SC-88 2.00x1.25x0.90, 0.65P**  
CASE 419B-02  
ISSUE Z

DATE 18 APR 2024

NOTES:

1. DIMENSIONING AND TOLERANCING CONFORM TO ASME Y14.5-2018.
2. ALL DIMENSION ARE IN MILLIMETERS.
3. DIMENSIONS D AND E1 DO NOT INCLUDE MOLD FLASH, PROTRUSIONS, OR GATE BURRS. MOLD FLASH, PROTRUSIONS, OR GATE BURRS SHALL NOT EXCEED 0.20 PER END.
4. DIMENSIONS D AND E1 AT THE OUTERMOST EXTREMES OF THE PLASTIC BODY AND DATUM H.
5. DATUMS A AND B ARE DETERMINED AT DATUM H.
6. DIMENSIONS b AND c APPLY TO THE FLAT SECTION OF THE LEAD BETWEEN 0.08 AND 0.15 FROM THE TIP.
7. DIMENSION b DOES NOT INCLUDE DAMBAR PROTRUSION. ALLOWABLE DAMBAR PROTRUSION SHALL BE 0.08 TOTAL IN EXCESS OF DIMENSION b AT MAXIMUM MATERIAL CONDITION. THE DAMBAR CANNOT BE LOCATED ON THE LOWER RADIUS OF THE FOOT.

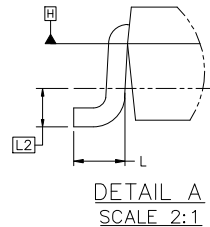
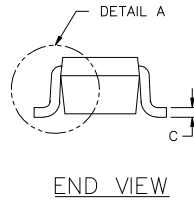
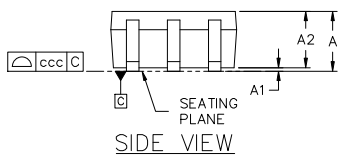
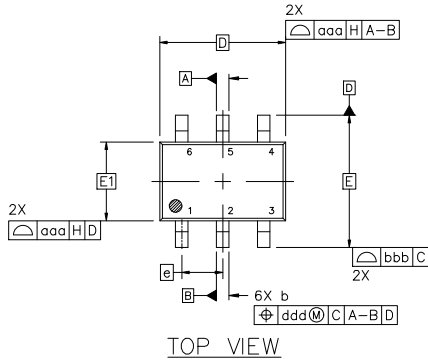

DIM	MILLIMETERS		
	MIN.	NOM.	MAX.
A	---	---	1.10
A1	0.00	---	0.10
A2	0.70	0.90	1.00
b	0.15	0.20	0.25
c	0.08	0.15	0.22
D	2.00 BSC		
E	2.10 BSC		
E1	1.25 BSC		
e	0.65 BSC		
L	0.26	0.36	0.46
L2	0.15 BSC		
aaa	0.15		
bbb	0.30		
ccc	0.10		
ddd	0.10		

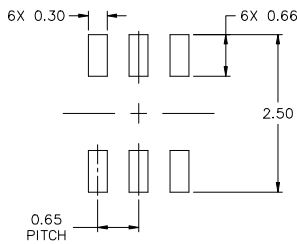

**GENERIC MARKING DIAGRAM\***

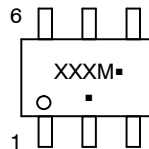

- XXX = Specific Device Code
- M = Date Code\*
- = Pb-Free Package

(Note: Microdot may be in either location)  
 \*Date Code orientation and/or position may vary depending upon manufacturing location.  
 \*This information is generic. Please refer to device data sheet for actual part marking. Pb-Free indicator, "G" or microdot "▪", may or may not be present. Some products may not follow the Generic Marking.

FOR ADDITIONAL INFORMATION ON OUR Pb-FREE STRATEGY AND SOLDERING DETAILS, PLEASE DOWNLOAD THE ONSEMI SOLDERING AND MOUNTING TECHNIQUES REFERENCE MANUAL, SOLDERRM/D.

**STYLES ON PAGE 2**

<b>DOCUMENT NUMBER:</b>	<b>98ASB42985B</b>	Electronic versions are uncontrolled except when accessed directly from the Document Repository. Printed versions are uncontrolled except when stamped "CONTROLLED COPY" in red.
<b>DESCRIPTION:</b>	<b>SC-88 2.00x1.25x0.90, 0.65P</b>	<b>PAGE 1 OF 2</b>

onsemi and ONSEMI are trademarks of Semiconductor Components Industries, LLC dba onsemi or its subsidiaries in the United States and/or other countries. onsemi reserves the right to make changes without further notice to any products herein. onsemi makes no warranty, representation or guarantee regarding the suitability of its products for any particular purpose, nor does onsemi assume any liability arising out of the application or use of any product or circuit, and specifically disclaims any and all liability, including without limitation special, consequential or incidental damages. onsemi does not convey any license under its patent rights nor the rights of others.

**SC-88 2.00x1.25x0.90, 0.65P**  
**CASE 419B-02**  
**ISSUE Z**

DATE 18 APR 2024

STYLE 1: PIN 1. EMITTER 2 2. BASE 2 3. COLLECTOR 1 4. EMITTER 1 5. BASE 1 6. COLLECTOR 2	STYLE 2: CANCELLED	STYLE 3: CANCELLED	STYLE 4: PIN 1. CATHODE 2. CATHODE 3. COLLECTOR 4. EMITTER 5. BASE 6. ANODE	STYLE 5: PIN 1. ANODE 2. ANODE 3. COLLECTOR 4. EMITTER 5. BASE 6. CATHODE	STYLE 6: PIN 1. ANODE 2 2. N/C 3. CATHODE 1 4. ANODE 1 5. N/C 6. CATHODE 2
STYLE 7: PIN 1. SOURCE 2 2. DRAIN 2 3. GATE 1 4. SOURCE 1 5. DRAIN 1 6. GATE 2	STYLE 8: CANCELLED	STYLE 9: PIN 1. EMITTER 2 2. EMITTER 1 3. COLLECTOR 1 4. BASE 1 5. BASE 2 6. COLLECTOR 2	STYLE 10: PIN 1. SOURCE 2 2. SOURCE 1 3. GATE 1 4. DRAIN 1 5. DRAIN 2 6. GATE 2	STYLE 11: PIN 1. CATHODE 2 2. CATHODE 2 3. ANODE 1 4. CATHODE 1 5. CATHODE 1 6. ANODE 2	STYLE 12: PIN 1. ANODE 2 2. ANODE 2 3. CATHODE 1 4. ANODE 1 5. ANODE 1 6. CATHODE 2
STYLE 13: PIN 1. ANODE 2. N/C 3. COLLECTOR 4. EMITTER 5. BASE 6. CATHODE	STYLE 14: PIN 1. VREF 2. GND 3. GND 4. IOUT 5. VEN 6. VCC	STYLE 15: PIN 1. ANODE 1 2. ANODE 2 3. ANODE 3 4. CATHODE 3 5. CATHODE 2 6. CATHODE 1	STYLE 16: PIN 1. BASE 1 2. EMITTER 2 3. COLLECTOR 2 4. BASE 2 5. EMITTER 1 6. COLLECTOR 1	STYLE 17: PIN 1. BASE 1 2. EMITTER 1 3. COLLECTOR 2 4. BASE 2 5. EMITTER 2 6. COLLECTOR 1	STYLE 18: PIN 1. VIN1 2. VCC 3. VOUT2 4. VIN2 5. GND 6. VOUT1
STYLE 19: PIN 1. IOUT 2. GND 3. GND 4. V CC 5. V EN 6. V REF	STYLE 20: PIN 1. COLLECTOR 2. COLLECTOR 3. BASE 4. EMITTER 5. COLLECTOR 6. COLLECTOR	STYLE 21: PIN 1. ANODE 1 2. N/C 3. ANODE 2 4. CATHODE 2 5. N/C 6. CATHODE 1	STYLE 22: PIN 1. D1 (i) 2. GND 3. D2 (i) 4. D2 (c) 5. VBUS 6. D1 (c)	STYLE 23: PIN 1. Vn 2. CH1 3. Vp 4. N/C 5. CH2 6. N/C	STYLE 24: PIN 1. CATHODE 2. ANODE 3. CATHODE 4. CATHODE 5. CATHODE 6. CATHODE
STYLE 25: PIN 1. BASE 1 2. CATHODE 3. COLLECTOR 2 4. BASE 2 5. EMITTER 6. COLLECTOR 1	STYLE 26: PIN 1. SOURCE 1 2. GATE 1 3. DRAIN 2 4. SOURCE 2 5. GATE 2 6. DRAIN 1	STYLE 27: PIN 1. BASE 2 2. BASE 1 3. COLLECTOR 1 4. EMITTER 1 5. EMITTER 2 6. COLLECTOR 2	STYLE 28: PIN 1. DRAIN 2. DRAIN 3. GATE 4. SOURCE 5. DRAIN 6. DRAIN	STYLE 29: PIN 1. ANODE 2. ANODE 3. COLLECTOR 4. EMITTER 5. BASE/ANODE 6. CATHODE	STYLE 30: PIN 1. SOURCE 1 2. DRAIN 2 3. DRAIN 2 4. SOURCE 2 5. GATE 1 6. DRAIN 1

Note: Please refer to datasheet for style callout. If style type is not called out in the datasheet refer to the device datasheet pinout or pin assignment.

<b>DOCUMENT NUMBER:</b>	<b>98ASB42985B</b>	Electronic versions are uncontrolled except when accessed directly from the Document Repository. Printed versions are uncontrolled except when stamped "CONTROLLED COPY" in red.
<b>DESCRIPTION:</b>	<b>SC-88 2.00x1.25x0.90, 0.65P</b>	<b>PAGE 2 OF 2</b>

**onsemi** and **ONSEMI** are trademarks of Semiconductor Components Industries, LLC dba **onsemi** or its subsidiaries in the United States and/or other countries. **onsemi** reserves the right to make changes without further notice to any products herein. **onsemi** makes no warranty, representation or guarantee regarding the suitability of its products for any particular purpose, nor does **onsemi** assume any liability arising out of the application or use of any product or circuit, and specifically disclaims any and all liability, including without limitation special, consequential or incidental damages. **onsemi** does not convey any license under its patent rights nor the rights of others.

**onsemi**, **Onsemi**, and other names, marks, and brands are registered and/or common law trademarks of Semiconductor Components Industries, LLC dba "**onsemi**" or its affiliates and/or subsidiaries in the United States and/or other countries. **onsemi** owns the rights to a number of patents, trademarks, copyrights, trade secrets, and other intellectual property. A listing of **onsemi**'s product/patent coverage may be accessed at [www.onsemi.com/site/pdf/Patent-Marking.pdf](http://www.onsemi.com/site/pdf/Patent-Marking.pdf). **onsemi** reserves the right to make changes at any time to any products or information herein, without notice. The information herein is provided "as-is" and **onsemi** makes no warranty, representation or guarantee regarding the accuracy of the information, product features, availability, functionality, or suitability of its products for any particular purpose, nor does **onsemi** assume any liability arising out of the application or use of any product or circuit, and specifically disclaims any and all liability, including without limitation special, consequential or incidental damages. Buyer is responsible for its products and applications using **onsemi** products, including compliance with all laws, regulations and safety requirements or standards, regardless of any support or applications information provided by **onsemi**. "Typical" parameters which may be provided in **onsemi** data sheets and/or specifications can and do vary in different applications and actual performance may vary over time. All operating parameters, including "Typicals" must be validated for each customer application by customer's technical experts. **onsemi** does not convey any license under any of its intellectual property rights nor the rights of others. **onsemi** products are not designed, intended, or authorized for use as a critical component in life support systems or any FDA Class 3 medical devices or medical devices with a same or similar classification in a foreign jurisdiction or any devices intended for implantation in the human body. Should Buyer purchase or use **onsemi** products for any such unintended or unauthorized application, Buyer shall indemnify and hold **onsemi** and its officers, employees, subsidiaries, affiliates, and distributors harmless against all claims, costs, damages, and expenses, and reasonable attorney fees arising out of, directly or indirectly, any claim of personal injury or death associated with such unintended or unauthorized use, even if such claim alleges that **onsemi** was negligent regarding the design or manufacture of the part. **onsemi** is an Equal Opportunity/Affirmative Action Employer. This literature is subject to all applicable copyright laws and is not for resale in any manner.

## ADDITIONAL INFORMATION

### TECHNICAL PUBLICATIONS:

Technical Library: [www.onsemi.com/design/resources/technical-documentation](http://www.onsemi.com/design/resources/technical-documentation)  
onsemi Website: [www.onsemi.com](http://www.onsemi.com)

### ONLINE SUPPORT: [www.onsemi.com/support](http://www.onsemi.com/support)

For additional information, please contact your local Sales Representative at [www.onsemi.com/support/sales](http://www.onsemi.com/support/sales)

## Looking for pricing, stock, or lifecycle information?

Click below to explore more details on WIN SOURCE:

 [View NLHV4157NDFT2G on WIN SOURCE](#)

 [ON Semiconductor](#) Information

## Optimize Your Supply Chain with WIN SOURCE Solutions

-  Global Sourcing Solution
-  Obsolete Management
-  Cost Control Management
-  Shortage Management
-  Alternative Solution
-  Excess Inventory Management