



**THE DATASHEET OF
CSRN2010FK50L0**



FEATURES

- Single input voltage range from 5V to 21V
- Wide input voltage range from 1.0V to 21V with external V_{CC} bias voltage
- Output voltage range from 0.6V to 0.86% P_{VIN}
- Enhanced line/load regulation with feedforward
- Programmable switching frequency up to 1.2MHz
- Three user selectable soft-start time
- User selectable LDO output voltage
- Enable input with voltage monitoring capability
- Thermally compensated current limit with robust hiccup mode over current protection
- Synchronization to an external clock
- Enhanced Pre-bias start-up
- Precise reference voltage (0.6V \pm 0.6%)
- Open-drain PGood indication
- Optional power up sequencing
- Integrated MOSFET drivers and bootstrap diode
- Thermal Shut Down
- Monotonic Start-Up
- Operating temp: $-40^{\circ}\text{C} < T_j < 125^{\circ}\text{C}$
- Package size: 4mm x 5mm PQFN
- Lead-free, Halogen-free and RoHS6 Compliant

DESCRIPTION

The IR3827 SupIRBuck™ is an easy-to-use, fully integrated and highly efficient DC/DC regulator. The onboard PWM controller and MOSFETs make IR3827 a space-efficient solution, providing accurate power delivery for low output voltage applications.

IR3827 is a versatile regulator which offers programmable switching frequency and internally set current limit while operating in wide range of input and output voltage conditions.

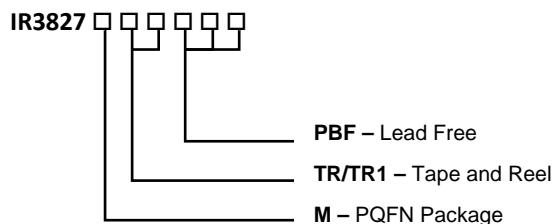
The switching frequency is programmable from 300kHz to 1.2MHz for an optimum solution. It also features important protection functions, such as Pre-Bias startup, thermally compensated current limit, over voltage protection and thermal shutdown to give required system level security in the event of fault conditions.

APPLICATIONS

- Computing Applications
- Set Top Box Applications
- Storage Applications
- Data Center Applications
- Distributed Point of Load Power Architectures

ORDERING INFORMATION

Base Part Number	Package Type	Standard Pack		Orderable Part Number
		Form	Quantity	
IR3827	PQFN 4 mm x 5 mm	Tape and Reel	750	IR3827MTR1PBF
IR3827	PQFN 4 mm x 5 mm	Tape and Reel	4000	IR3827MTRPBF



BASIC APPLICATION

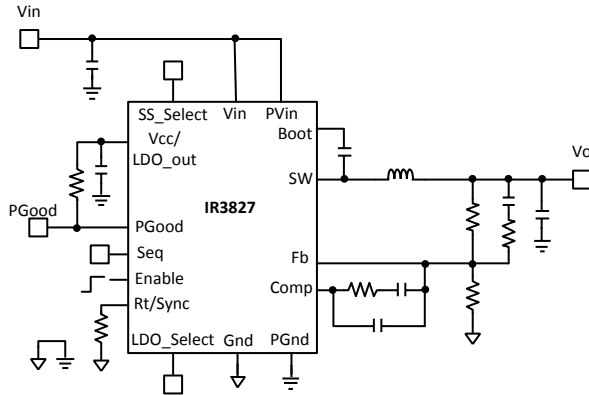


Figure 1 IR3827 Basic Application Circuit

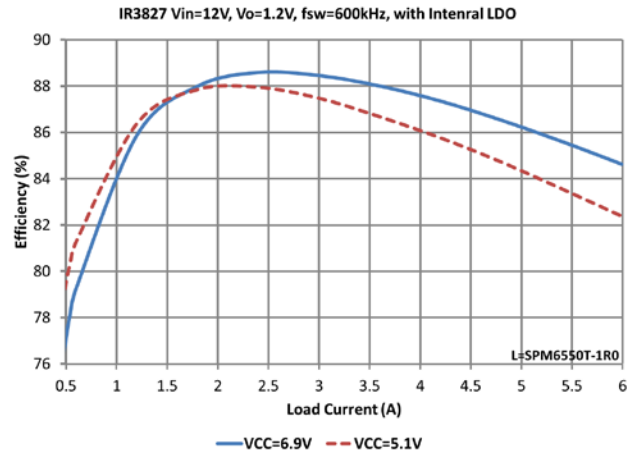


Figure 2 IR3827 Efficiency

PINOUT DIAGRAM

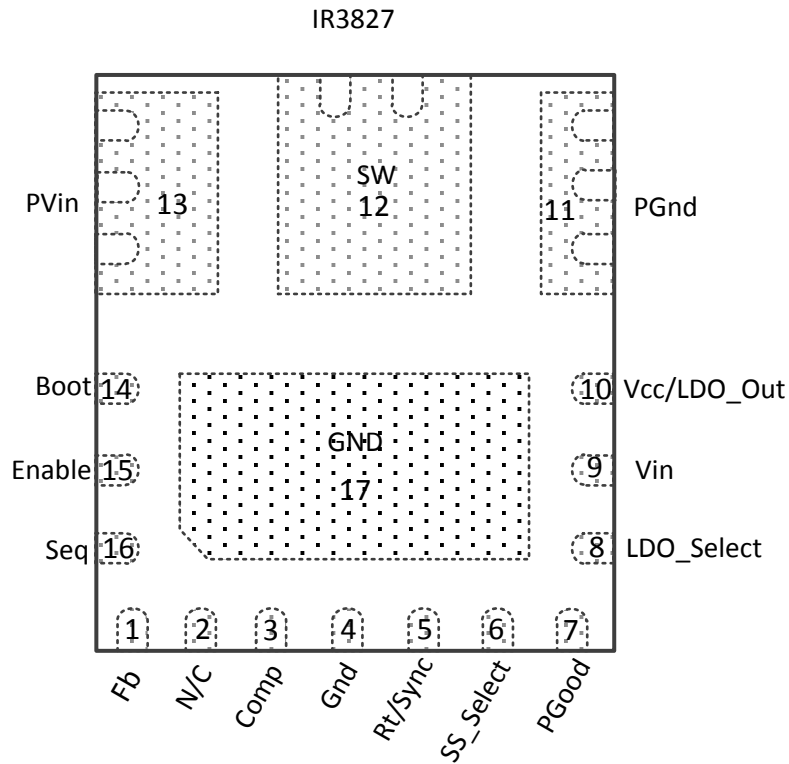
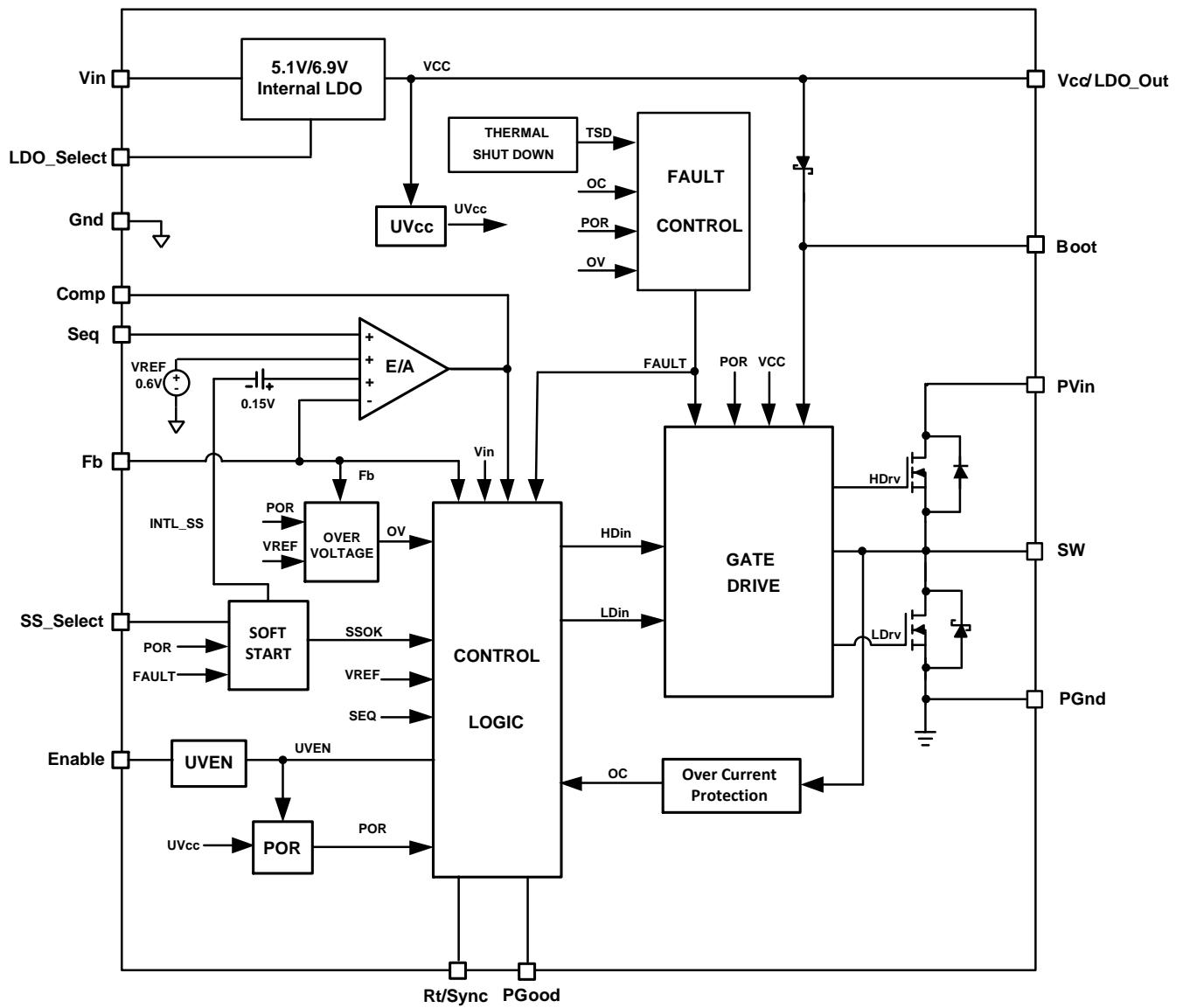


Figure 3 4mm x 5mm PQFN (Top View)

BLOCK DIAGRAM

Figure 4 Simplified Block Diagram

PIN DESCRIPTIONS

PIN #	PIN NAME	PIN DESCRIPTION
1	Fb	Inverting input to the error amplifier. This pin is connected directly to the output of the regulator via a resistor divider to set the output voltage and to provide the feedback signal to the error amplifier.
2	N/C	Should not be connected to other signals on PCB layout. It is internally connected for testing purpose.
3	Comp	Output of error amplifier. An external resistor and capacitor network is typically connected from this pin to Fb pin to form a loop compensator.
4, 17	Gnd	Signal ground for internal reference and control circuitry.
5	Rt/Sync	Multi-function pin to set the switching frequency. The internal oscillator frequency is set with a resistor between this pin and Gnd. Or synchronization to an external clock by connecting this pin to the external clock signal through a diode.
6	SS_Select	Soft start selection pin. Three user selectable soft start time is available: 1.5ms (SS_Select=Vcc), 3ms (SS_Select=Float), 6ms (SS_Select=Gnd)
7	PGood	Open-drain power good indication pin. Connect a pull-up resistor from this pin to Vcc.
8	LDO_Select	LDO output voltage selection pin. Float gives 5.1V and low 0V (Gnd) gives 6.9V
9	V _{in}	Input for internal LDO. A 1.0 μ F capacitor should be connected between this pin and PGnd. If external supply is connected to Vcc/LDO_out pin, this pin should be shorted to Vcc/LDO_out pin. Connecting this pin to PV _{in} can also implement the input voltage feedforward.
10	Vcc/LDO_Out	Output of the internal LDO and optional input of an external biased supply voltage. A minimum 2.2 μ F ceramic capacitor is recommended between this pin and PGnd.
11	PGnd	Power Ground. This pin serves as a separated ground for the MOSFET drivers and should be connected to the system's power ground plane.
12	SW	Switch node. Connected this pin to the output inductor.
13	PV _{in}	Input voltage for power stage.
14	Boot	Supply voltage for high side driver, a 100nF capacitor should be connected between this pin and SW pin.
15	Enable	Enable pin to turn on and off the device. Input voltage monitoring (input UVLO) can also be implemented by connecting this pin to PVin pin through a resistor divider.
16	Seq	Sequence pin to do simultaneous and ratiometric sequencing operation. A resistor divider can be connected from master output to this pin for sequencing mode of operation. If not used, leave it open.
17	Gnd	Signal ground for internal reference and control circuitry.

ABSOLUTE MAXIMUM RATINGS

Stresses beyond these listed under “Absolute Maximum Ratings” may cause permanent damage to the device. These are stress ratings only and functional operation of the device at these or any other conditions beyond those indicated in the operational sections of the specifications are not implied.

PVin, Vin to PGnd (Note 4)	-0.3V to 25V
Vcc/LDO_Out to PGnd (Note 4)	-0.3V to 8V (Note 1)
Boot to PGnd (Note 4)	-0.3V to 33V
SW to PGnd (Note 4)	-0.3V to 25V (DC), -4V to 25V (AC, 100ns)
Boot to SW	-0.3V to V _{CC} + 0.3V (Note 2)
PGood, SS_Select to Gnd (Note 4)	-0.3V to V _{CC} + 0.3V (Note 2)
Other Input/Output Pins to Gnd (Note 4)	-0.3V to +3.9V
PGnd to Gnd	-0.3V to +0.3V
THERMAL INFORMATION	
Junction to Ambient Thermal Resistance Θ_{JA}	32 °C/W (Note 3)
Junction to PCB Thermal Resistance Θ_{j-PCB}	2 °C/W
Storage Temperature Range	-55°C to 150°C
Junction Temperature Range	-40°C to 150°C

Note 1: Vcc must not exceed 7.5V for Junction Temperature between -10°C and -40°C

Note 2: Must not exceed 8V

Note 3: Based on IRDC3827 demo board - 2.6"x2.2", 4-layer PCB board using 2 oz. copper on each layer.

Note 4: PGnd pin and Gnd pin are connected together.

ELECTRICAL SPECIFICATIONS

RECOMMENDED OPERATING CONDITIONS

	SYMBOL	MIN	MAX	UNITS
Input Voltage Range with External V _{cc} Note 5, Note 7	PV _{in}	1.0	21	V
Input Voltage Range with Internal LDO Note 6, Note 7	V _{in} , PV _{in}	5.5	21	
Supply Voltage Range (Note 6)	V _{cc}	4.5	7.5	
Supply Voltage Range (Note 6)	Boot to SW	4.5	7.5	
Output Voltage Range	V _o	0.6	0.86 x PV _{in}	
Output Current Range	I _o	0	6	A
Switching Frequency	F _s	300	1200	kHz
Operating Junction Temperature	T _j	-40	125	°C

Note 5: V_{in} is connected to V_{cc} to bypass the internal LDO.

Note 6: V_{in} is connected to PV_{in}. For single-rail applications with PV_{in}=V_{in}= 4.5V-5.5V, please refer to the application information in the section of User Selectable Internal LDO and the section of Over Current Protection.

Note 7: Maximum SW node voltage should not exceed 25V.

ELECTRICAL CHARACTERISTICS

Unless otherwise specified, these specifications apply over, 5.5V < V_{in} = PV_{in} < 21V, 0°C < T_j < 125°C, LDO_Select=Gnd, SS_Select=Float. Typical values are specified at T_a = 25°C.

PARAMETER	SYMBOL	CONDITIONS	MIN	TYP	MAX	UNITS
Power Stage						
Power Losses	P _{LOSS}	PV _{in} =V _{in} = 12V, V _o =1.2V, I _o = 6A, F _s =600kHz, L=1.0uH, LDO_Select=Gnd. Note 8		1.1		W
		PV _{in} =V _{in} =12V, V _o =1.2V, I _o =6A, F _s =600kHz, L=1.0uH, LDO_Select=Float. Note 8		1.3		
Top Switch R _{DS(ON)}	R _{DS(on)-T}	V _{BOOT} -V _{sw} =5.1V, I _o = 6A, T _j = 25°C		21	29	mΩ
		V _{BOOT} -V _{sw} =6.9V, I _o = 6A, T _j = 25°C		16	22	
Bottom Switch R _{DS(ON)}	R _{DS(on)-B}	V _{cc} = 5.1V, I _o = 6A, T _j = 25°C		21.4	30	
		V _{cc} = 6.9V, I _o = 6A, T _j = 25°C		16.8	23	
Bootstrap Diode Forward Voltage	V _D	I(Boot) = 10mA	180	260	470	mV
SW Leakage Current		V _{SW} = 0V, Enable = 0V			1	μA
		V _{SW} = 0V, Enable = High, V _{SEQ} =0V			1	μA
Dead Band Time	T _D	Note 8		10		ns

ELECTRICAL CHARACTERISTICS (CONTINUED)

Unless otherwise specified, these specifications apply over, $5.5V < V_{in} = PV_{in} < 21V$, $0^{\circ}C < T_J < 125^{\circ}C$, LDO_Select=Gnd, SS_Select=Float. Typical values are specified at $T_a = 25^{\circ}C$.

PARAMETER	SYMBOL	CONDITIONS	MIN	TYP	MAX	UNITS
Supply Current						
Vin Supply Current (standby)	$I_{in(Standby)}$	EN = Low, No Switching			200	μA
Vin Supply Current (dynamic)	$I_{in(Dyn)}$	EN = High, $F_s = 600kHz$, $V_{in} = PV_{in} = 21V$, LDO_Select=Gnd		10	13	mA
		EN = High, $F_s = 600kHz$, $V_{in} = PV_{in} = 21V$, LDO_Select=Float		8	11	
V_{cc}/LDO_Out						
Output Voltage	V_{cc}	$V_{in(min)} = 5.5V$, $I_o = 0-30mA$, Load = 2.2 μF , LDO_Select=Float	4.75	5.1	5.4	V
		$V_{in(min)} = 7.3V$, $I_o = 0-30mA$, Load = 2.2 μF , LDO_Select=Gnd	6.5	6.9	7.2	
LDO_Select Input bias Current		LDO_Select=Gnd		30	60	μA
LDO Dropout Voltage	V_{cc_drop}	$V_{in}=6.5V$, $I_o=30mA$, Load=2.2 μF , LDO_Select=Gnd			0.7	V
		$V_{in}=4.7V$, $I_o=25mA$, Load=2.2 μF , LDO_Select=Float			0.7	
Short Circuit Current	I_{short}	LDO_Select=Gnd		70		mA
Oscillator						
Rt Voltage	V_{Rt}			1.0		V
Frequency Range	F_s	Rt = 80.6k Ω	270	300	330	kHz
		Rt = 39.2k Ω	540	600	660	
		Rt = 19.1k Ω	1080	1200	1320	
Ramp Amplitude	V_{ramp}	$V_{in} = 7.3V$, Vin slew rate max = 1V/ μs , Note 8		1.095		V_{p-p}
		$V_{in} = 12V$, Vin slew rate max = 1V/ μs , Note 8		1.80		
		$V_{in} = 21V$, Vin slew rate max = 1V/ μs , Note 8		3.15		
		$V_{in}=V_{cc}=5V$, For external V_{cc} operation, Note 8		0.75		

ELECTRICAL CHARACTERISTICS (CONTINUED)

Unless otherwise specified, these specifications apply over, $5.5V < V_{in} = PV_{in} < 21V$, $0^{\circ}C < T_J < 125^{\circ}C$, LDO_Select=Gnd, SS_Select=Float. Typical values are specified at $T_a = 25^{\circ}C$.

PARAMETER	SYMBOL	CONDITIONS	MIN	TYP	MAX	UNITS
Ramp Offset		Note 8		0.16		V
Minimum Pulse Width	$T_{min(ctrl)}$	Note 8			60	ns
Maximum Duty Cycle	D_{max}	$F_s = 300kHz, V_{in} = PV_{in} = 12V$	86			%
Fixed Off Time	T_{off}	Note 8		200	250	ns
Sync Frequency Range	F_{sync}		270		1320	kHz
Sync Pulse Duration	T_{sync}		100	200		ns
Sync Level Threshold	High		3			V
	Low				0.6	
Error Amplifier						
Input Offset Voltage		$V_{FB} - V_{SEQ}, V_{SEQ}=0.3V$	-3		+3	%
Input Bias Current (V_{FB})	$I_{FB}(E/A)$		-1		+1	μA
Input Bias Current (V_{SEQ})	$I_{SEQ}(E/A)$		0		+4	
Sink Current	$I_{sink}(E/A)$		0.4	0.85	1.2	mA
Source Current	$I_{source}(E/A)$		4	7.5	11	mA
Slew Rate	SR	Note 8	7	12	20	V/ μs
Gain-Bandwidth Product	GBWP	Note 8	20	30	40	MHz
DC Gain	Gain	Note 8	100	110	120	dB
Maximum Output Voltage	$V_{max}(E/A)$		1.7	2.0	2.3	V
Minimum Output Voltage	$V_{min}(E/A)$				100	mV
Common Mode Input Voltage			0		1.2	V
Reference Voltage (V_{REF})						
Feedback Voltage	V_{FB}	LDO_Select= Gnd		0.6		V
		LDO_Select= Float		0.6		
Accuracy		$0^{\circ}C < T_j < 70^{\circ}C$	-0.6		+0.6	%
		$-40^{\circ}C < T_j < 125^{\circ}C$; Note 9	-1.2		+1.2	
Soft Start						
Soft Start Ramp Rate		SS_Select=High	0.34	0.4	0.46	mV/ μs
		SS_Select=Float	0.17	0.2	0.23	
		SS_Select=Gnd	0.085	0.1	0.115	
SS_Select Input Bias Current		LDO_Select=Gnd SS_Select=Gnd		40	80	μA

ELECTRICAL CHARACTERISTICS (CONTINUED)

Unless otherwise specified, these specifications apply over, $5.5V < V_{in} = PV_{in} < 21V$, $0^{\circ}C < T_J < 125^{\circ}C$, LDO_Select=Gnd, SS_Select=Float. Typical values are specified at $T_a = 25^{\circ}C$.

PARAMETER	SYMBOL	CONDITIONS	MIN	TYP	MAX	UNITS
Power Good						
Power Good Turn on Threshold	$V_{PG(on)}$	V_{FB} rising	85	90	95	% V_{REF}
Power Good Lower Turn off Threshold	$V_{PG(lower)}$	V_{FB} falling	80	85	90	% V_{REF}
Power Good Turn on Delay	$T_{PG(ON)_D}$	V_{FB} rising, see $V_{PG(on)}$		2.56		ms
Power Good Upper Turn off Threshold	$V_{PG(upper)}$	V_{FB} rising	115	120	125	% V_{REF}
PGood Comparator Delay		$V_{FB} < V_{PG(lower)}$ or $V_{FB} > V_{PG(upper)}$	1	2	3.5	μs
PGood Voltage Low	$PG(voltage)$	$I_{PGood} = -5mA$			0.5	V
Under-Voltage Lockout						
V_{cc} -Start Threshold	$V_{CC} UVLO Start$	V_{cc} rising trip Level	3.9	4.1	4.3	V
V_{cc} -Stop Threshold	$V_{CC} UVLO Stop$	V_{cc} falling trip Level	3.6	3.8	4.0	V
Enable-Start-Threshold	Enable UVLO Start	ramping up	1.14	1.2	1.26	V
Enable-Stop-Threshold	Enable UVLO Stop	ramping down	0.95	1	1.05	
Enable Leakage Current	I_{EN_LK}	Enable = 3.3V			1	μA
Over-Voltage Protection						
OVP Trip Threshold	OVP_V_{th}	V_{FB} rising	115	120	125	% V_{REF}
OVP Comparator Delay	T_{OVP_D}		1	2	3.5	μs
Over-Current Protection						
Current Limit	I_{LIMIT}	$T_j = 25^{\circ}C$, LDO_Select=Float	6.2	7.3	8.5	A
		$T_j = 25^{\circ}C$, LDO_Select=Gnd	7.9	9.3	10.8	
Hiccup Blanking Time	T_{BLK_Hiccup}	SS_Select = Vcc, Note 8		10		ms
		SS_Select = Float, Note 8		20		
		SS_Select = Gnd, Note 8		40		

ELECTRICAL CHARACTERISTICS (CONTINUED)

Unless otherwise specified, these specifications apply over, $5.5V < V_{in} = PV_{in} < 21V$, $0^{\circ}C < T_J < 125^{\circ}C$, LDO_Select=Gnd, SS_Select=float. Typical values are specified at $T_a = 25^{\circ}C$.

PARAMETER	SYMBOL	CONDITIONS	MIN	TYP	MAX	UNITS
Upper Gate Driver						
Source Resistance		$V_{BOOT}-V_{SW} = 5.1V$, Note 8		3		Ω
Sink Resistance		$V_{BOOT}-V_{SW} = 5.1V$, Note 8		4		
Lower Gate Driver						
Source Resistance		$V_{CC} = 5.1V$, Note 8		2		Ω
Sink Resistance		$V_{CC} = 5.1V$, Note 8		0.8		
Over-Temperature Protection						
Thermal Shutdown Threshold		Note 8		145		$^{\circ}C$
Hysteresis		Note8		20		

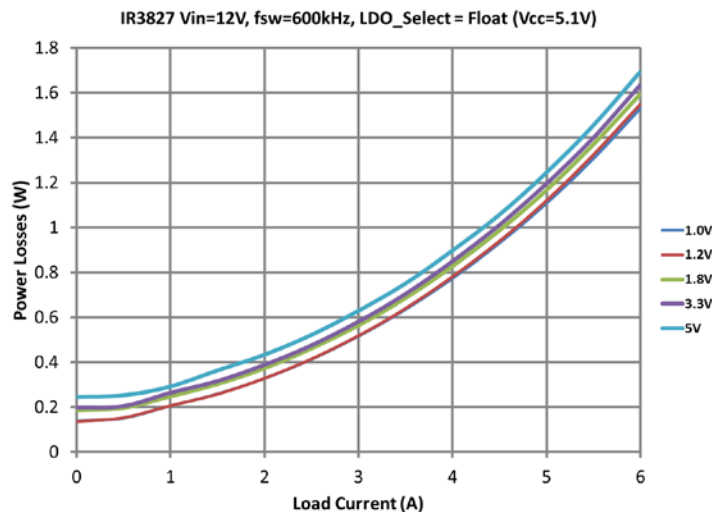
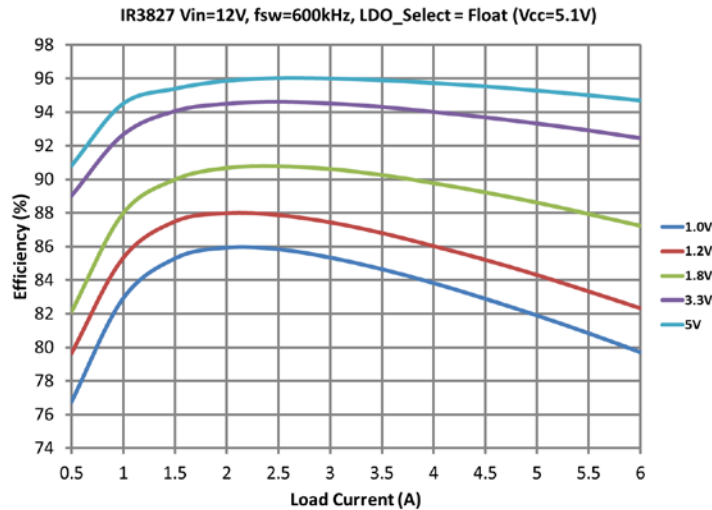
Note 8: Guaranteed by design, but not tested in production.

Note 9: Cold temperature performance is guaranteed via correlation using statistical quality control. Not tested in production.

TYPICAL EFFICIENCY AND POWER LOSS CURVES

$PV_{in} = 12V$, $V_{CC} = \text{Internal LDO}$, $LDO_Select = \text{Float}$, $I_O = 0A-6A$, $F_S = 600\text{ kHz}$, Room Temperature, No Air Flow. Note that the efficiency and power loss curves include the losses of IR3827, the inductor losses and the losses of the input and output capacitors. The table below shows the inductors used for each of the output voltages in the efficiency measurement.

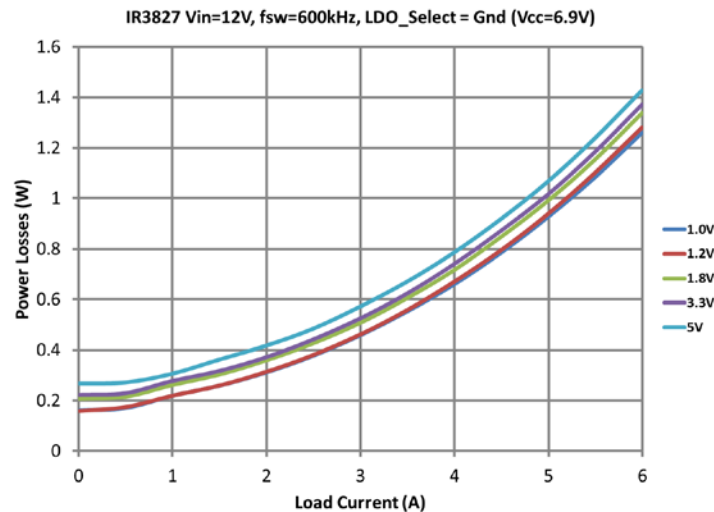
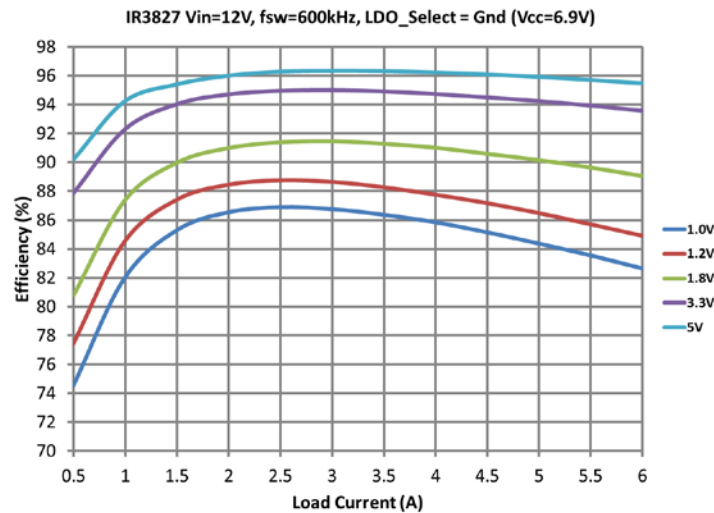
VOUT (V)	LOUT (μH)	P/N	DCR ($\text{m}\Omega$)
1.0	0.82	SPM6550T-R82M (TDK)	4.2
1.2	1.0	SPM6550T-1R0M (TDK)	4.7
1.8	1.0	SPM6550T-1R0M (TDK)	4.7
3.3	2.2	7443340220(Wurth Elektronik)	4.4
5	2.2	7443340220(Wurth Elektronik)	4.4



TYPICAL EFFICIENCY AND POWER LOSS CURVES

$P_{V_{in}} = 12V$, $V_{CC} = \text{Internal LDO}$, $LDO_Select = \text{Gnd}$, $I_o = 0A-6A$, $F_S = 600 \text{ kHz}$, Room Temperature, No Air Flow. Note that the efficiency and power loss curves include the losses of IR3827, the inductor losses and the losses of the input and output capacitors. The table below shows the inductors used for each of the output voltages in the efficiency measurement.

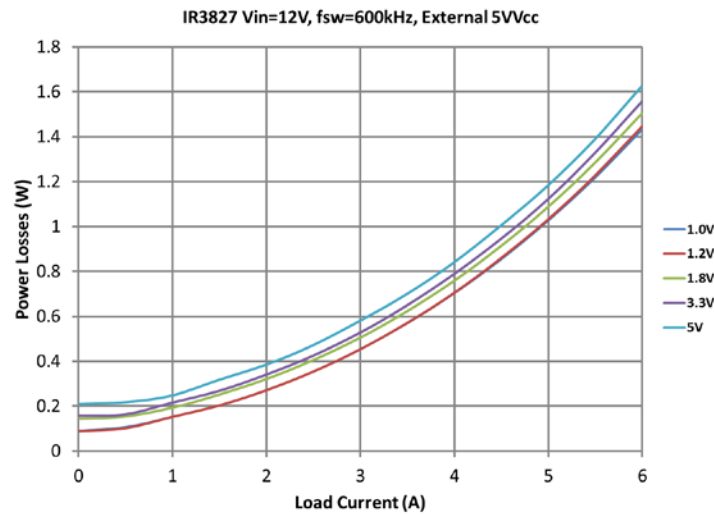
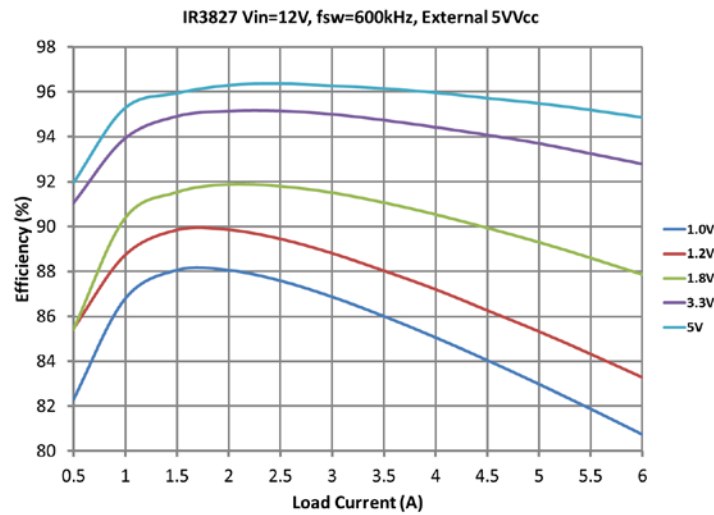
VOUT (V)	LOUT (μH)	P/N	DCR ($\text{m}\Omega$)
1.0	0.82	SPM6550T-R82M (TDK)	4.2
1.2	1.0	SPM6550T-1R0M (TDK)	4.7
1.8	1.0	SPM6550T-1R0M (TDK)	4.7
3.3	2.2	7443340220(Wurth Elektronik)	4.4
5	2.2	7443340220(Wurth Elektronik)	4.4



TYPICAL EFFICIENCY AND POWER LOSS CURVES

$P_{V_{in}} = 12V$, $V_{CC} = \text{External } 5V$, $I_O = 0A-6A$, $F_S = 600 \text{ kHz}$, Room Temperature, No Air Flow. Note that the efficiency and power loss curves include the losses of IR3827, the inductor losses and the losses of the input and output capacitors. The table below shows the inductors used for each of the output voltages in the efficiency measurement.

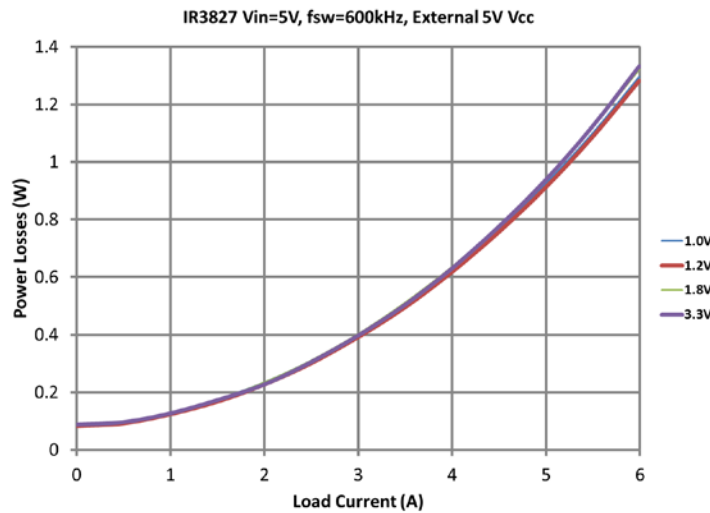
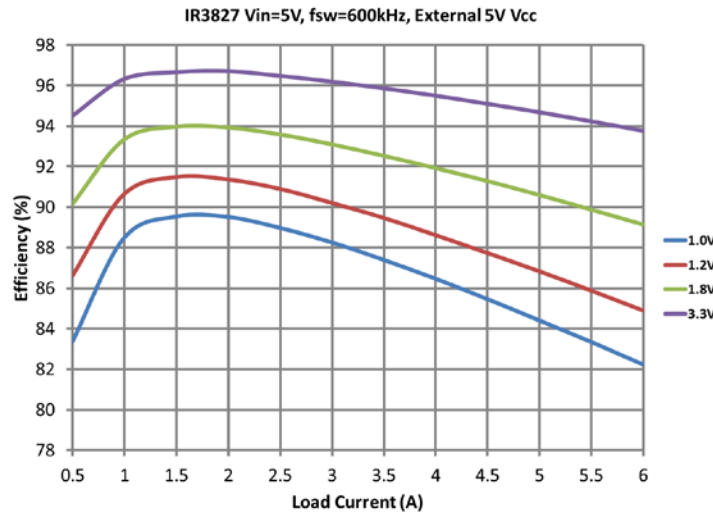
VOUT (V)	LOUT (μH)	P/N	DCR (m Ω)
1.0	0.82	SPM6550T-R82M (TDK)	4.2
1.2	1.0	SPM6550T-1R0M (TDK)	4.7
1.8	1.0	SPM6550T-1R0M (TDK)	4.7
3.3	2.2	7443340220(Wurth Elektronik)	4.4
5	2.2	7443340220(Wurth Elektronik)	4.4

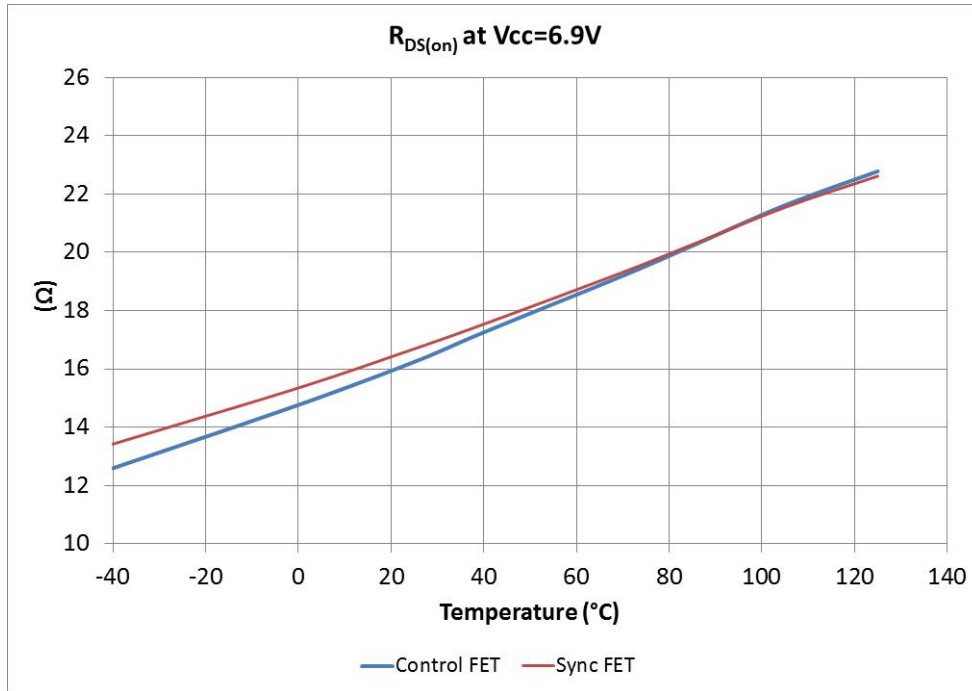
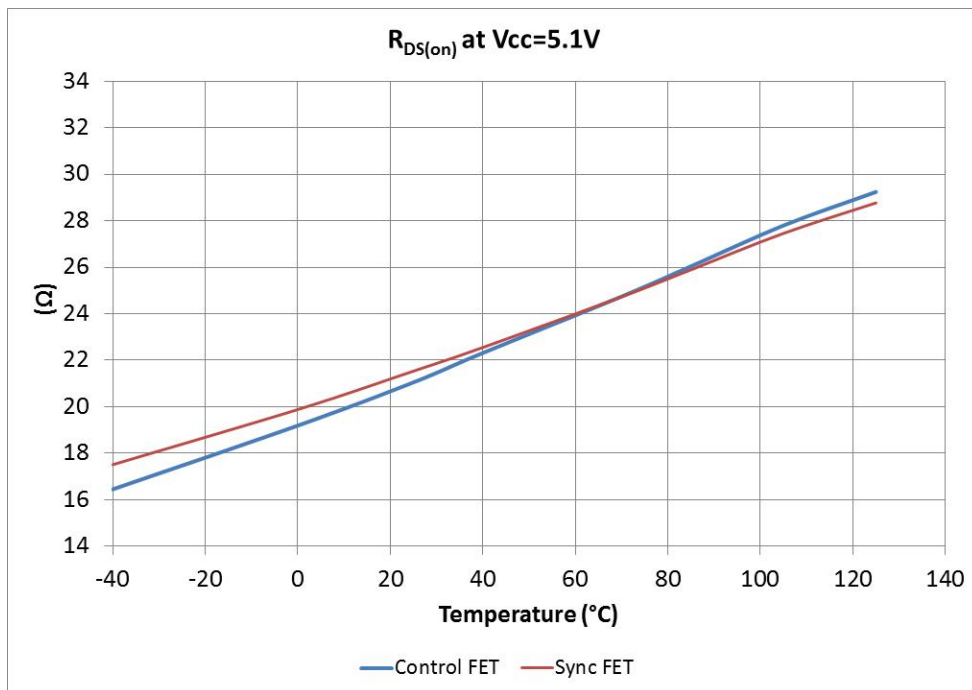


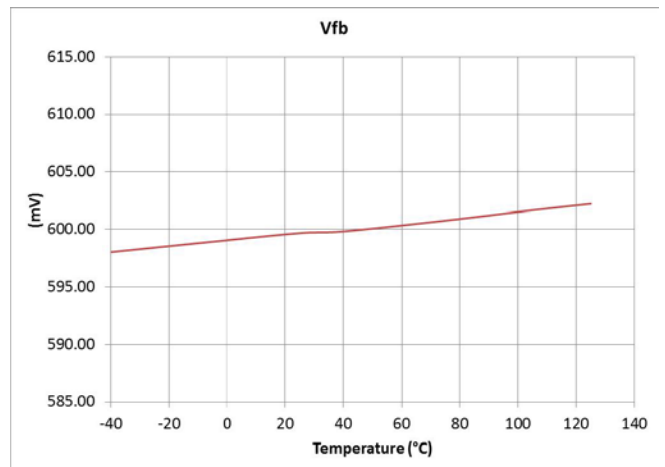
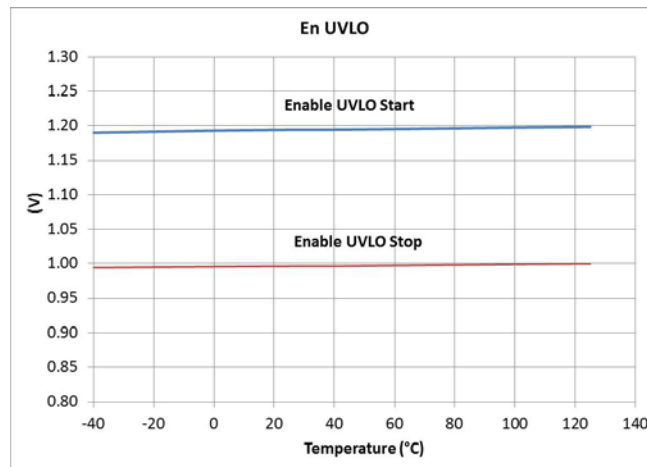
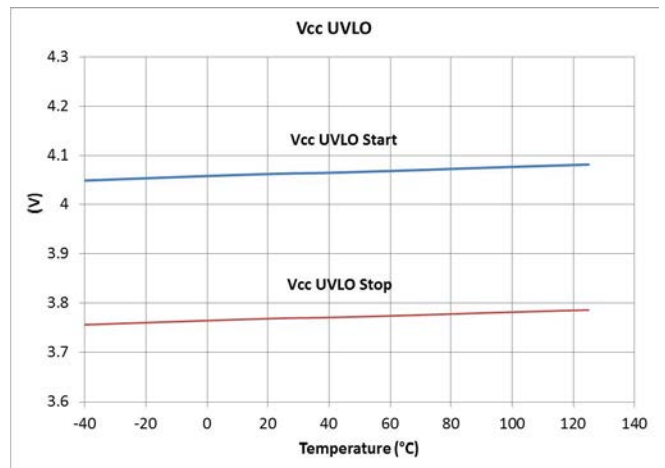
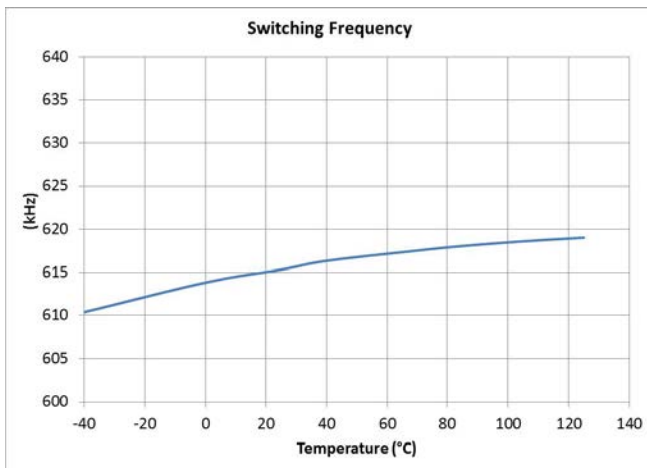
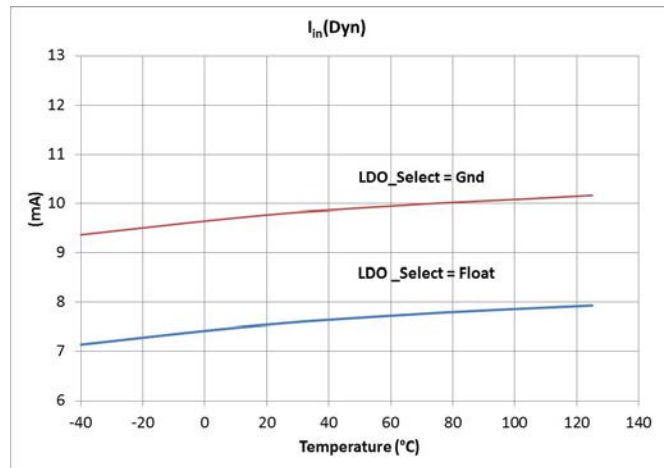
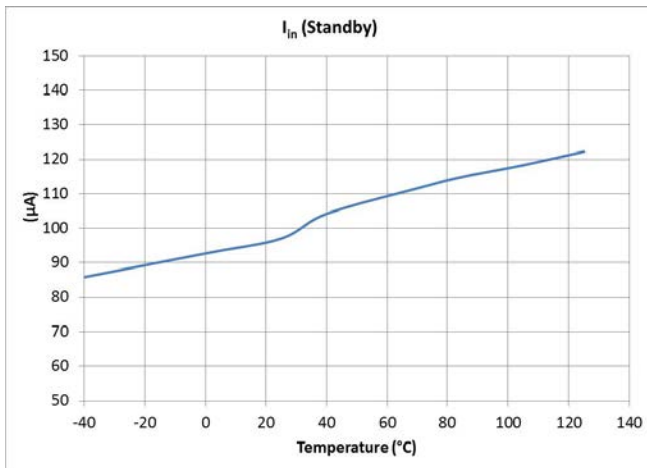
TYPICAL EFFICIENCY AND POWER LOSS CURVES

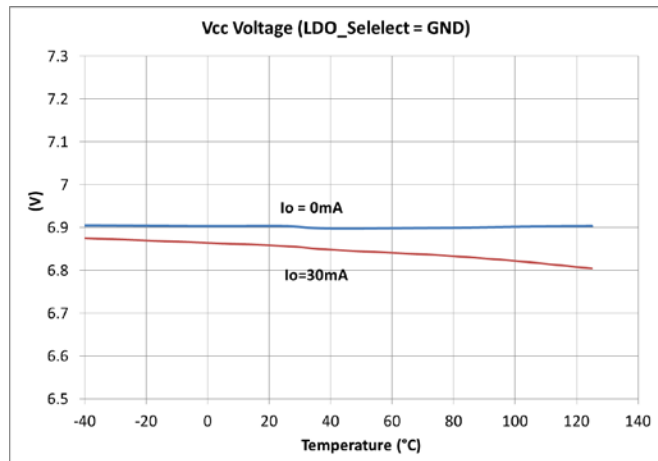
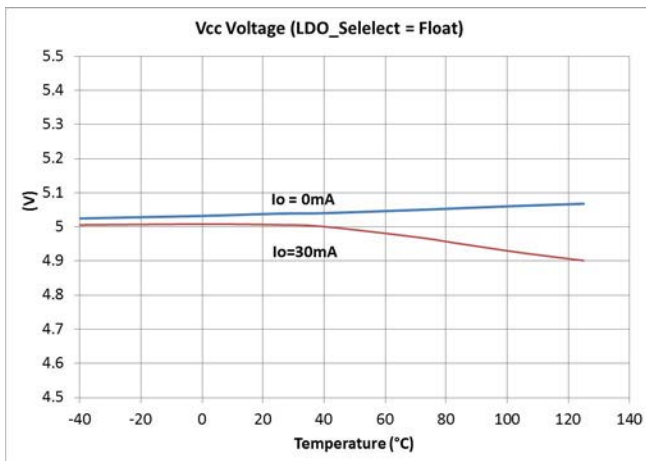
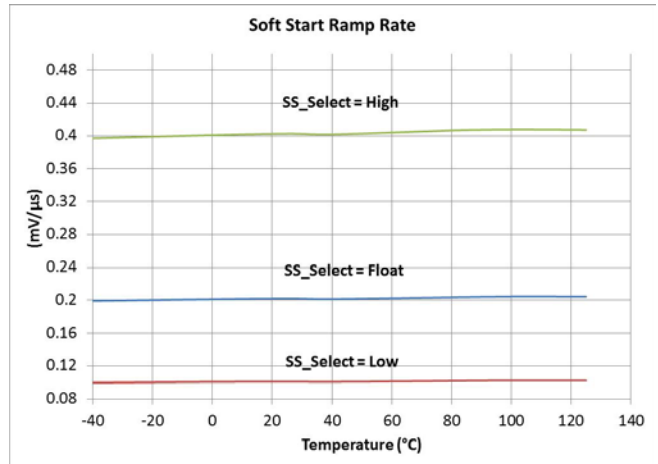
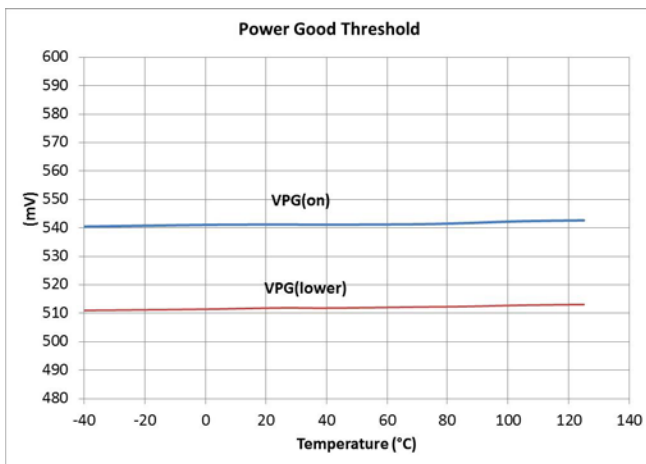
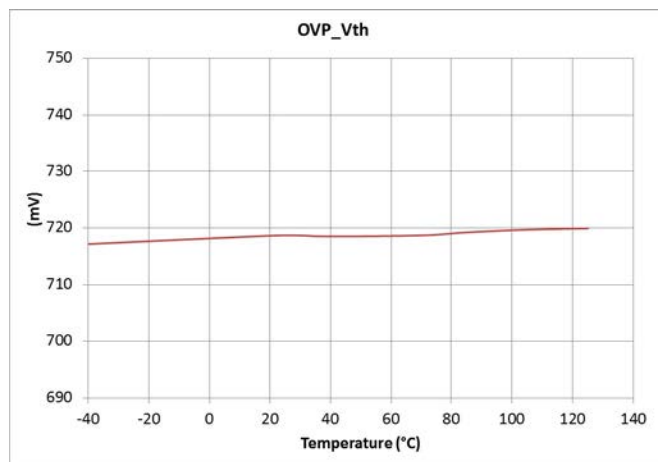
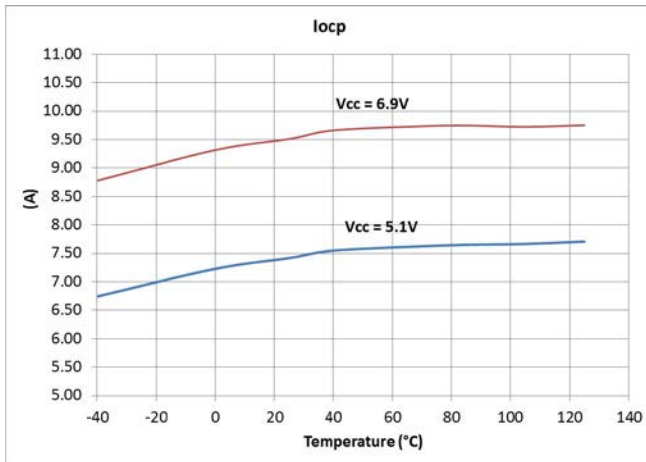
$P_{V_{in}} = V_{in} = V_{CC} = 5V$, $I_O = 0A-6A$, $F_S = 600\text{ kHz}$, Room Temperature, No Air Flow. Note that the efficiency and power loss curves include the losses of IR3827, the inductor losses and the losses of the input and output capacitors. The table below shows the inductors used for each of the output voltages in the efficiency measurement.

VOUT (V)	LOUT (μH)	P/N	DCR ($\text{m}\Omega$)
1.0	0.68	PCMB065T- R68MS (Cyntec)	3.9
1.2	0.82	SPM6550T-R82M(TDK)	4.2
1.8	0.82	SPM6550T-R82M(TDK)	4.7
3.3	1.0	SPM6550T-1R0M(TDK)	4.7



$R_{DS(on)}$ OF MOSFETS OVER TEMPERATURE AT $V_{CC}=6.9V$

 $R_{DS(on)}$ OF MOSFETS OVER TEMPERATURE AT $V_{CC}=5.1V$


TYPICAL OPERATING CHARACTERISTICS (-40°C TO +125°C)


TYPICAL OPERATING CHARACTERISTICS (-40°C TO +125°C)


THEORY OF OPERATION

DESCRIPTION

The IR3827 SupIRBuck™ is a 6A easy-to-use, fully integrated and highly efficient synchronous Buck regulator intended for Point-Of-Load (POL) applications. It includes two IR HEXFETs with low $R_{DS(on)}$. The bottom FET has an integrated monolithic schottky diode in place of a conventional body diode.

The IR3827 provides precisely regulated output voltage programmed via two external resistors from 0.6V to $0.86 \times V_{in}$. It uses voltage mode control employing a proprietary PWM modulator with input voltage feedforward. That provides excellent noise immunity, easy loop compensation design, and good line transient response.

The IR3827 has a user-selectable internal Low Dropout (LDO) Regulator, allowing single supply operation without resorting to an external bias supply voltage. To further improve the efficiency, the internal LDO can be bypassed. Instead an external bias supply can be used. This feature allows the input bus voltage range extended to 1.0V.

The IR3827 features programmable switching frequency from 300kHz to 1.2MHz, three selectable soft-start time, and smooth synchronization to an external clock. The other important functions include thermally compensated over current protection, output over voltage protection and thermal shut-down, etc.

VOLTAGE LOOP COMPENSATION DESIGN

The IR3827 uses PWM voltage mode control. The output voltage of the POL, sensed by a resistor divider, is fed into an internal Error Amplifier (E/A). The output of the E/R is then compared to an internal ramp voltage to determine the pulse width of the gate signal for the control FET. The amplitude of the ramp voltage is proportional to V_{in} so that the bandwidth of the voltage loop remains almost constant for different input voltages. This feature is called input voltage feedforward. It allows the feedback loop design independent of the input voltage. Please refer to the next section for more information.

A RC network has to be connected between the FB pin and the COMP pin to form a feedback compensator. The goal of the compensator design is to achieve a high control bandwidth with a phase margin of 45° or above. The high control bandwidth is beneficial for the loop dynamic response, which helps to reduce the number of output capacitors, PCB size and the cost. A phase margin of 45° or higher is desired to ensure the system stability. For most applications, a gain margin of -10dB or higher is preferred to accommodate component variations and to eliminate jittering/noise. The proprietary PWM modulator in IR3827 significantly reduces the PWM jittering, allowing the control bandwidth in the range of $1/10^{\text{th}}$ to $1/5^{\text{th}}$ of the switching frequency.

Two types of compensators are commonly used: Type II (PI) and Type III (PID), as shown in Figure 5. The selection of the compensation type is dependent on the ESR of the output capacitors. Electrolytic capacitors have relatively higher ESR. If the ESR pole is located at the frequency lower than the cross-over frequency, F_C , the ESR pole will help to boost the phase margin. Thus a type II compensator can be used. For the output capacitors with lower ESR such as ceramic capacitors, type III compensation is often desired.

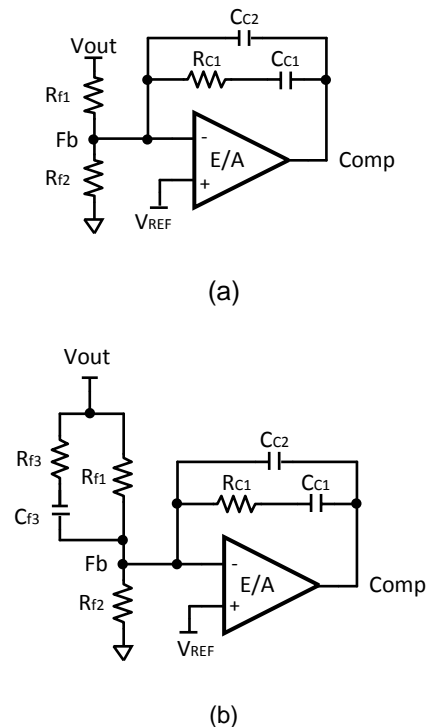


Figure 5 Loop Compensator (a) Type II, (b) Type III

Table 1 lists the compensation selection for different types of output capacitors.

For more detailed design guideline of voltage loop compensation, please refer to the application note AN-1162, “*Compensation Design Procedure for Buck Converter with Voltage-Mode Error-Amplifier*”. SupBuck design tool is also available at www.irf.com providing the reference design based on user’s design requirements.

TABLE 1 RECOMMENDED COMPENSATION TYPE

COMPENSATOR	LOCATION OF CROSS-OVER FREQUENCY	TYPE OF OUTPUT CAPACITORS
Type II (PI)	$F_{LC} < F_{ESR} < F_0 < F_S/2$	Electrolytic, POS-CAP, SP-CAP
Type III-A (PID)	$F_{LC} < F_0 < F_{ESR} < F_S/2$	POS-CAP, SP-CAP
Type III-B (PID)	$F_{LC} < F_0 < F_S/2 < F_{ESR}$	Ceramic

F_{LC} is the resonant frequency of the output LC filter. It is often referred to as double pole.

$$F_{LC} = \frac{1}{2 \times \pi \sqrt{L_o \times C_o}}$$

F_{ESR} is the ESR zero of the output capacitor.

$$F_{ESR} = \frac{1}{2\pi \times ESR \times C_o}$$

F_0 is the cross-over frequency of the closed voltage loop and F_S is the switching frequency.

INPUT VOLTAGE FEEDFORWARD

Input voltage feedforward is an important feature, because it can keep the converter stable and preserve its load transient performance when V_{in} varies in a large range. In IR3827, feedforward function is enabled when V_{in} pin is connected to PV_{in} pin and $V_{in} > 5.5V$. In this case, the internal low dropout (LDO) regulator is used. The PWM ramp amplitude (V_{ramp}) is proportionally changed with V_{in} to maintain the ratio V_{in}/V_{ramp} almost constant throughout V_{in} variation range (as shown in Figure 6). Thus, the control loop bandwidth and phase margin can be maintained constant. Feed-forward

function can also minimize impact on output voltage from fast V_{in} change. The maximum V_{in} slew rate is within $1V/\mu s$.

If an external bias voltage is used as V_{CC} , V_{in} pin should be connected to V_{CC}/LDO_out pin instead of PV_{in} pin. Then the feedforward function is disabled. The control loop compensation might need to be adjusted.

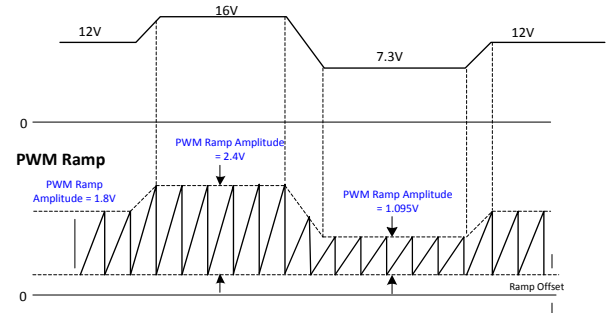


Figure 6 Timing Diagram for Input Feedforward

UNDER-VOLTAGE LOCKOUT AND POR

The Under-Voltage Lockout (UVLO) circuit monitors the voltage of V_{CC}/LDO_Output pin and the Enable pin. It assures that the MOSFET driver outputs remain off whenever either of these two signals is below the set thresholds. Normal operation resumes once both V_{CC}/LDO_Output and En voltages rise above their thresholds.

The POR (Power On Ready) signal is generated when all these signals reach the valid logic level (see system block diagram). When the POR is asserted, the soft start sequence starts (see soft start section).

ENABLE/EXTERNAL PVIN MONITOR

The IR3827 has an Enable function providing another level of flexibility for start-up. The Enable pin has a precise threshold which is internally monitored by Under-Voltage Lockout (UVLO) circuit. If the voltage at Enable pin is below its UVLO threshold, both high-side and low-side FETs are off. When Enable pin is below its UVLO, Over-Voltage Protection (OVP) is disabled, and PGood stays low.

The Enable pin should not be left floating. A pull-down resistor in the range of several kilo ohms is recommended to connect between the Enable Pin and Gnd.

In addition to logical inputs, the Enable pin can be used to implement precise input voltage UVLO. As shown in Figure 7, the input of the Enable pin is derived from the PV_{in} voltage by a set of resistive divider, R1 and R2. By selecting different divider ratios, users can program the UVLO threshold voltage. The bus voltage UVLO is a very desirable feature. It prevents the IR3827 from regulating at PV_{in} lower than the desired voltage level. Figure 8 shows the start-up waveform with the input UVLO voltage set at 10V.

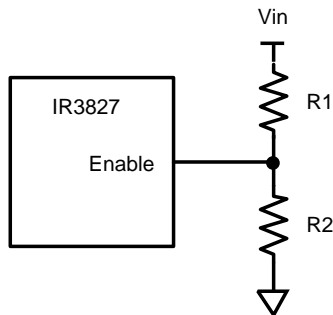


Figure 7 Implementation of Input Under-Voltage Lockout (UVLO) using Enable Pin

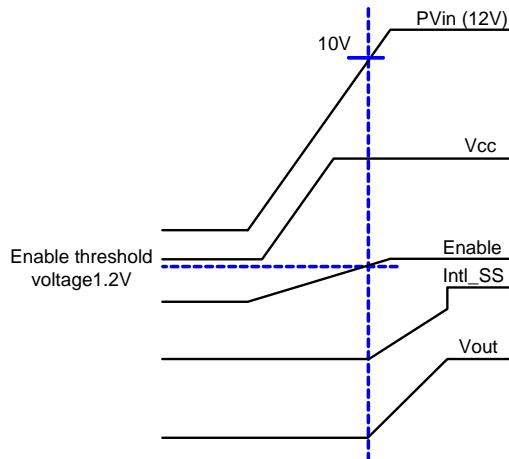


Figure 8 Illustration of start-up with PV_{in} UVLO threshold voltage of 10V. The internal soft-start is used in this case.

USER SELECTABLE INTERNAL LDO

The IR3827 has an internal Low Dropout Regulator (LDO), offering two LDO voltage options – 5.1V and 6.9V. 5.1V V_{CC} voltage results in higher light load efficiency due to the lower gate charge loss, while 6.9V V_{CC} voltage results in higher full load efficiency due to less conduction loss. User can select the desired V_{CC} voltage based on the design target. The selection of the LDO voltage is achieved with LDO_Select pin, as shown in Table 2. It should be noted that 6.9V V_{CC} voltage results in faster switching speed and may cause higher voltage spike at the SW node than 5.1V V_{CC} voltage.

TABLE 2 CONFIGURATION OF INTERNAL LDO

LDO_SELECT	VCC/LDO_OUT
Float	5.1V
Gnd	6.9V

The internal LDO is beneficial for single rail (supply) applications, where no external bias supplies will be needed. For these applications, V_{in} pin should be connected to PV_{in} and V_{CC}/LDO_{Out} pin is left floating as shown in Figure 9. 1.0 μ F and 2.2 μ F ceramic bypass capacitors should be placed close to V_{in} pin and V_{CC}/LDO_{Out} pin respectively.

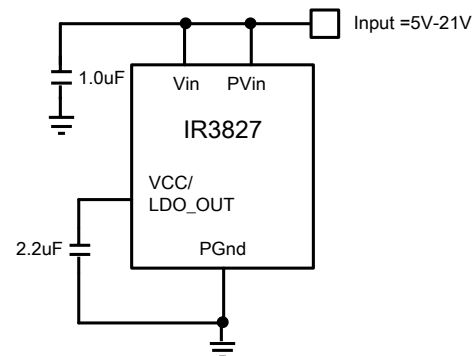


Figure 9 Internally Biased Single-Rail Configuration

When V_{in} drops below 5.5V (LDO_Select = Float), or 7.3V (LDO_Select = Gnd), the internal LDO enters the dropout mode. Figure 10 shows the V_{CC}/LDO_{Out} voltage for $V_{in}=PV_{in}=5V$ with switching frequency of 600kHz and 1200kHz respectively. Alternatively, if the input bus voltage, PV_{in} , is in the range of 4.5V to 7.5V, V_{CC}/LDO_{Out} pin can be

directly connected to the PV_{in} pin to bypass the internal LDO and therefore to avoid the voltage drop on the internal LDO. This configuration is illustrated in Figure 11.

Figure 12 shows the configuration using an external V_{CC} voltage. With this configuration, the input voltage range can be extended down to 1.0V. Please note that the input feedforward function is disabled for this configuration. The feedback compensation needs to be adjusted accordingly.

It should be noted as the V_{CC} voltage decreases, the efficiency and the over current limit will decrease due to the increase of R_{DS(ON)}. Please refer to the section of the over current protection for more information.

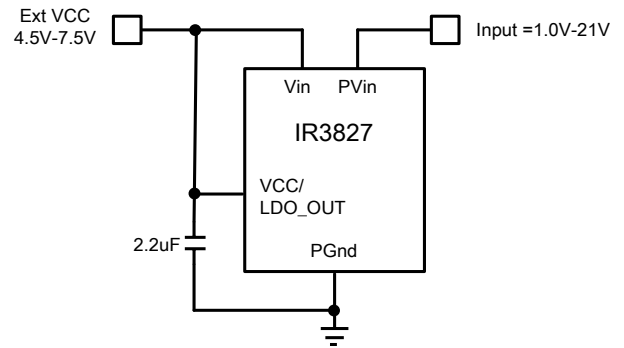


Figure 12 Use External Bias Voltage

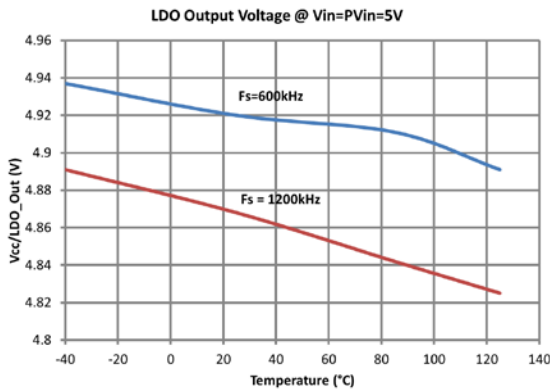


Figure 10 LDO Dropout Voltage at V_{in}=PV_{in}=5V

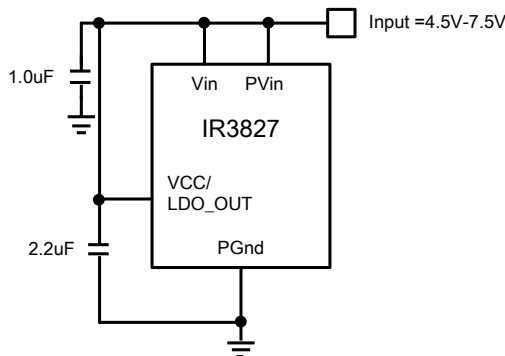


Figure 11 Single-Rail Configuration for 4.5V-7V inputs

SOFT-START

The IR3827 has an internal digital soft-start circuit to control the output voltage rise time, and to limit the current surge at the start-up. To ensure correct start-up, the soft-start sequence initiates when the Enable and V_{cc} voltages rise above their UVLO thresholds and generate the Power On Ready (POR) signal. The slew rate of the internal soft-start can be adjusted externally with SS_Select pin, as shown in Table 3.

Table 3 User Selectable Soft-Start Time

SS_Select	Slew Rate (mV/μs)	Soft-Start Time (ms)
Vcc	0.4	1.5
Float	0.2	3
Gnd	0.1	6

Figure 13 shows the waveforms during the soft start. The corresponding soft-start time can be calculated as follows.

$$T_{ss} = \frac{0.75V - 0.15V}{SlewRate}$$

It should be noted that during the soft-start the over-current protection (OCP) and over-voltage protection (OVP) is enabled to protect the device for any short circuit or over voltage condition.

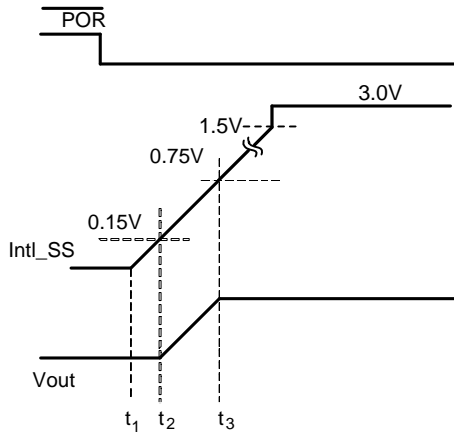


Figure 13 Theoretical start-up waveforms using internal soft-start

POWER UP SEQUENCING

The IR3827 provides the simultaneous or ratiometric sequencing function with Seq pin. As shown in the block diagram, the Error-Amplifier (E/A) has three positive inputs. The input with the lowest voltage is used for regulating the output voltage and the other two inputs are ignored. In practice, the voltage of the other two inputs should be about 200mV greater than the low-voltage input so that their effects can completely be ignored. Seq pin is internally biased to 3.3V via a high impedance path. For normal operation, Seq pin is left floating.

In sequencing operation, the voltage at Seq pin, V_{SEQ} , should be kept to zero until the internal soft-start is finished. Then V_{SEQ} is ramped up and the feedback voltage, V_{FB} , follows V_{SEQ} . When V_{SEQ} is above 0.6V, the Error-Amplifier switches to V_{REF} and V_{FB} starts to follow V_{REF} . The final V_{SEQ} voltage after sequencing startup should be between 0.7V ~ 3.3V.

Figure 14 shows the typical application circuit for sequencing operation. V_{SEQ} is derived from the output of another voltage regulator (Master) through a resistor divider composed of R_E and R_F . If the ratio of this resistor divider is equal to that of the feedback resistor divider i.e. $R_E/R_F = R_C/R_D$, simultaneous start-up is achieved. That is, the output voltage of the slave follows that of the master until the voltage at the Seq pin of the slave reaches 0.6 V. After V_{SEQ} of the slave exceeds 0.6V, the internal 0.6V reference voltage of the slave dictates its output. To achieve ratiometric operation, $R_E/R_F > R_C/R_D$ should

be used. Table 4 summarizes the configurations to achieve simultaneous/ratiometric sequencing operations and normal start-up using the internal soft-start. Figure 15 shows the typical waveforms for sequencing operations.

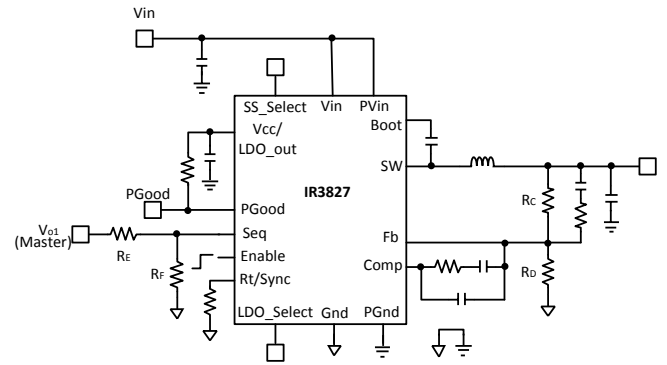


Figure 14 Application circuit for Simultaneous and Ratiometric sequencing operation

Table 4 Start-Up Configurations

Operating Mode	V_{SEQ}	Configuration
Internal soft-start	Floating	—
Simultaneous Sequencing	Ramp up from 0V	$R_E/R_F = R_C/R_D$
Ratiometric Sequencing	Ramp up from 0V	$R_E/R_F > R_C/R_D$

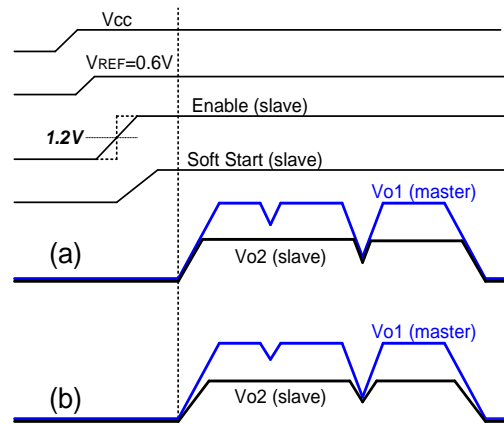


Figure 15 Typical waveforms for sequencing operation: (a) Simultaneous; (b) Ratiometric

PRE-BIAS START-UP

IR3827 is able to start up into a pre-charged output smoothly, which prevents oscillations and disturbances of the output voltage.

The output starts in an asynchronous fashion and keeps the synchronous MOSFET (Sync FET) off until the first gate signal for control MOSFET (Ctrl FET) is generated. Figure 16 shows a typical Pre-Bias condition at start up. The gate signal of the control FET is determined by the loop compensator. The sync FET always starts with a narrow pulse width (12.5% of a switching period) and gradually increases its duty cycle with a step of 12.5% until it reaches the steady state value. The number of these startup pulses for each step is 16 and it's internally programmed. Figure 17 shows the series of 16x8 startup pulses.

It should be noted that PGood is not active until the first gate signal for control FET is generated. Please refer to Power Good Section for more information.

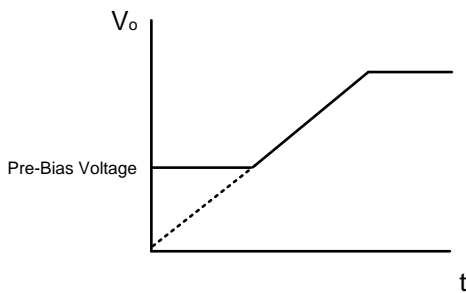


Figure 16 Pre-Bias start-up

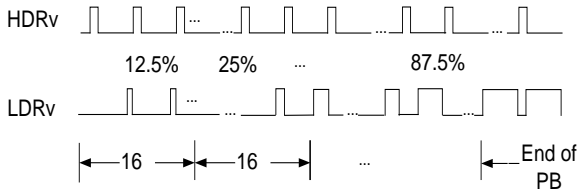


Figure 17 Pre-Bias startup pulses

SHUTDOWN

IR3827 can be shut down by pulling the Enable pin below its 1.0V threshold. Both the high side and the low side drivers are pulled low.

OPERATING FREQUENCY

The switching frequency can be programmed between 300kHz – 1200kHz by connecting an

external resistor from Rt pin to Gnd. Rt can be calculated as follows.

$$F_s = 19954 \times R_t^{-0.953}$$

Where F_s is in kHz, and R_t is in k Ω .

Table 5 shows the different oscillator frequency and its corresponding R_t for easy reference.

Table 5 Switching Frequency vs. R_t

R_t (k Ω)	F_s (kHz)
80.6	300
60.4	400
48.7	500
39.2	600
34	700
29.4	800
26.1	900
23.2	1000
21	1100
19.1	1200

OVER CURRENT PROTECTION

The over current (OC) protection is performed by sensing current through the $R_{DS(on)}$ of the Synchronous MOSFET. This method enhances the converter's efficiency, reduces cost by eliminating a current sense resistor and any layout related noise issues. The current limit is pre-set internally and is compensated according to the IC temperature. So at different ambient temperature, the over-current trip threshold remains almost constant.

Detailed operation of OCP is explained as follows. Over Current Protection circuit senses the inductor current flowing through the Synchronous MOSFET closer to the valley point. OCP circuit samples this current for 40nsec typically after the rising edge of the PWM set pulse which has a width of 12.5% of the switching period. The PWM pulse starts at the falling edge of the PWM set pulse. This makes valley current sense more robust as current is sensed close to the bottom of the inductor downward slope where transient and switching noise are lower and helps to prevent false tripping due to noise and transient. An OC condition is detected if the load current exceeds the threshold, the converter enters into hiccup mode. PGood will go low and the internal

soft start signal will be pulled low. The converter goes into hiccup mode with some hiccup blanking time as shown in Figure 18. The converter stays in this mode until the over load or short circuit is removed. With different SS_Select configurations, the hiccup blanking time is different. Please refer to the electrical table for details. The actual DC output current limit point will be greater than the valley point by an amount equal to approximately half of peak to peak inductor ripple current.

$$I_{OCP} = I_{LIMIT} + \frac{\Delta i}{2}$$

I_{OCP} = DC current limit hiccup point
 I_{LIMIT} = Over current limit (Valley of Inductor Current)
 Δi = Peak-to-peak inductor ripple current

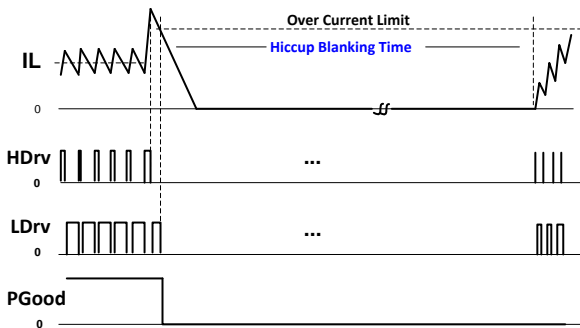


Figure 18 Timing Diagram for Hiccup Over Current Protection

Over current limit is affected by the V_{CC} voltage. For some single rail operations where V_{in} is 5V or less, the OCP limit will de-rated due to the drop of V_{CC} voltage. Figure 19 and Figure 20 show the over current limit for two single rail applications with $V_{in}=PV_{in}=5V$ and $V_{in}=PV_{in}=V_{CC}=4.5V$ respectively.

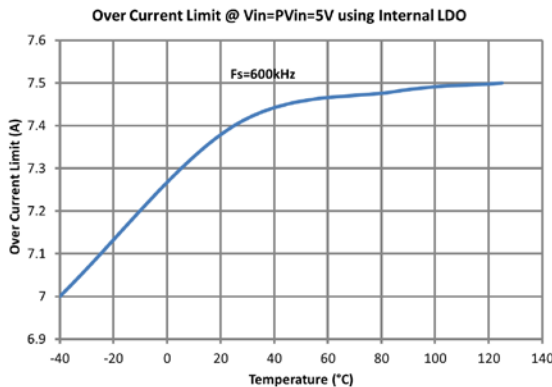


Figure 19 OCP Limit at $V_{in}=PV_{in}=5V$ using Internal LDO

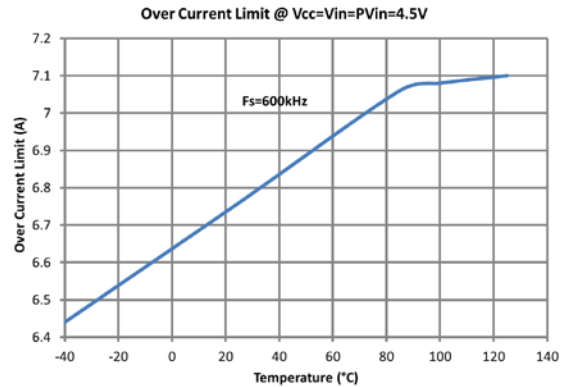


Figure 20 OCP Limit at $V_{in}=PV_{in}=V_{CC}=4.5V$

OVER-VOLTAGE PROTECTION (OVP)

Over-voltage protection in IR3827 is achieved by comparing FB pin voltage to a pre-set threshold. OVP threshold is set at $1.2 \times V_{ref}$. When FB pin voltage exceeds the over voltage threshold, an over voltage trip signal asserts after 2 μs (typ.) delay. Then the high side drive signal HDrv is turned off immediately, PGood flags low. The sync FET remains on to discharge the output capacitor. When the V_{FB} voltage drops below the threshold, the sync FET turns off to prevent the complete depletion of the output capacitor. After that, HDrv remains off until a reset is performed by cycling either V_{CC} or Enable. Figure 21 shows the timing diagram for over voltage protection. Please note that OVP comparator becomes active only when the IR3827 is enabled.

POWER GOOD OUTPUT

IR3827 continually monitors the output voltage via FB voltage. The FB voltage is an input to the window comparator with upper and lower threshold of 120% and 85% of the reference voltage respectively. PGood signal is high whenever FB voltage is within the PGood comparator window thresholds. For pre-biased start-up, PGood is not active until the first gate signal of the control FET is generated.

The PGood pin is open drain and it needs to be externally pulled high. High state indicates that output is in regulation.

In addition, PGood is also gated by other faults including over current and over temperature. When

either of the faults occurs, PGood pin will be pulled low.

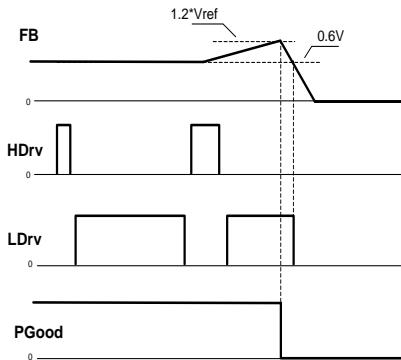


Figure 21 Timing Diagram for Over Voltage Protection

THERMAL SHUTDOWN

Temperature sensing is provided inside IR3827. The trip threshold is typically set to 145°C. When trip threshold is exceeded, thermal shutdown turns off both MOSFETs and resets the internal soft start.

Automatic restart is initiated when the sensed temperature drops within the operating range. There is a 20°C hysteresis in the thermal shutdown threshold.

EXTERNAL SYNCHRONIZATION

IR3827 incorporates an internal phase lock loop (PLL) circuit which enables synchronization of the internal oscillator to an external clock. This function is important to avoid sub-harmonic oscillations due to beat frequency for embedded systems when multiple point-of-load (POL) regulators are used. A multi-function pin, Rt/Sync, is used to connect the external clock. If the external clock is present before the converter turns on, Rt/Sync pin can be connected to the external clock signal solely and no other resistor is needed. If the external clock is applied after the converter turns on, or the converter switching frequency needs to toggle between the external clock frequency and the internal free-running frequency, an external resistor from Rt/Sync pin to Gnd is required to set the free-running frequency.

When an external clock is applied to Rt/Sync pin after the converter runs in steady state with its free-

running frequency, a transition from the free-running frequency to the external clock frequency will happen. This transition is to gradually make the actual switching frequency equal to the external clock frequency, no matter which one is higher. On the contrary, when the external clock signal is removed from Rt/Sync pin, the switching frequency is also changed to free-running gradually. In order to minimize the impact from these transitions to output voltage, a diode is recommended to add between the external clock and Rt/Sync pin, as shown in Figure 22. Figure 23 shows the timing diagram of these transitions.

An internal compensation circuit is used to change the PWM ramp slope according to the clock frequency applied on Rt/Sync pin. Thus, the effective amplitude of the PWM ramp (V_{ramp}), which is used in compensation loop calculation, has minor impact from the variation of the external synchronization signal.

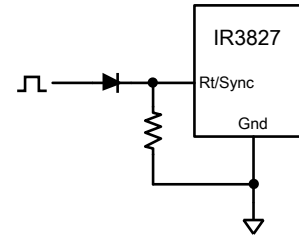


Figure 22 Configuration of External Synchronization

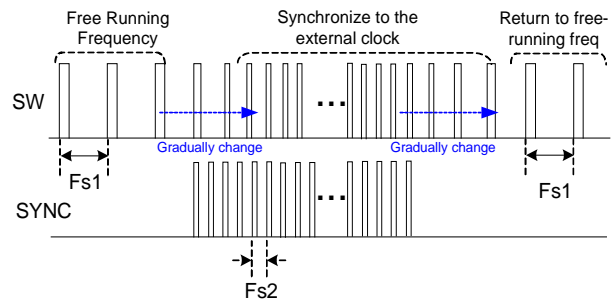


Figure 23 Timing Diagram for Synchronization to the External Clock ($F_{s1} < F_{s2}$ or $F_{s1} > F_{s2}$)

MINIMUM ON TIME CONSIDERATIONS

The minimum ON time is the shortest amount of time for which Ctrl FET may be reliably turned on, and this depends on the internal timing delays. For IR3827, the worst case minimum on-time is specified as 60 ns.

Any design or application using IR3827 must ensure operation with a pulse width that is higher than this minimum on-time and preferably higher than 60ns. This is necessary for the circuit to operate without jitter and pulse-skipping, which can cause high inductor current ripple and high output voltage ripple.

$$t_{on} = \frac{D}{F_s} = \frac{V_{out}}{V_{in} \times F_s}$$

In any application that uses IR3827, the following condition must be satisfied:

$$t_{on(min)} \leq t_{on}$$

$$t_{on(min)} \leq \frac{V_{out}}{V_{in} \times F_s}, \text{ therefore, } V_{in} \times F_s \leq \frac{V_{out}}{t_{on(min)}}$$

The minimum output voltage is limited by the reference voltage and hence $V_{out(min)} = 0.6 \text{ V}$. Therefore,

$$V_{in} \times F_s \leq \frac{V_{out(min)}}{t_{on(min)}} = \frac{0.6\text{V}}{60\text{ns}} = 10\text{V} / \mu\text{s}$$

Therefore, at the maximum recommended input voltage 21V and minimum output voltage, the converter should be designed at a switching frequency that does not exceed 476 kHz. Conversely, for operation at the maximum recommended operating frequency (1.32 MHz) and minimum output voltage (0.6V). The input voltage (PV_{in}) should not exceed 7.57V, otherwise pulse skipping will happen.

MAXIMUM DUTY RATIO

A certain off-time is specified for IR3827. This provides an upper limit on the operating duty ratio at any given switching frequency. The off-time remains at a relatively fixed ratio to switching period in low and mid frequency range, while in high frequency

range this ratio increases, thus the lower the maximum duty ratio at which IR3827 can operate. Figure 24 shows a plot of the maximum duty ratio vs. the switching frequency.

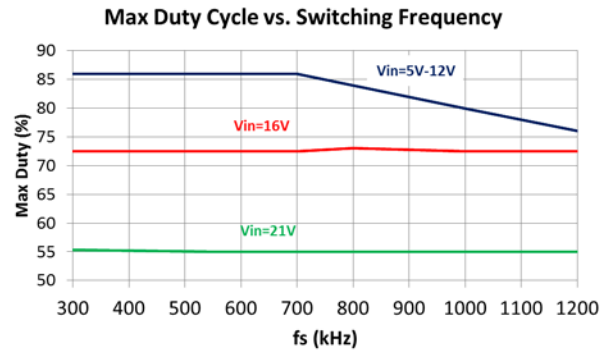


Figure 24 Maximum duty cycle vs. switching frequency.

DESIGN EXAMPLE

The following example is a typical application for IR3827. The application circuit is shown in Figure 28.

$$PV_{in} = V_{in} = 12V (\pm 10\%)$$

$$V_o = 1.2V$$

$$I_o = 6A$$

Peak-to-Peak Ripple Voltage = $\pm 1\%$ of V_o

$$\Delta V_o = \pm 4\% \text{ of } V_o \text{ (for 30\% Load Transient)}$$

$$F_s = 600 \text{ kHz}$$

EXTERNAL PVIN MONITOR (INPUT UVLO)

As explained in the section of Enable/External PV_{in} monitor, the input voltage, PV_{in} , can be monitored by connecting the Enable pin to PV_{in} through a set of resistor divider. When PV_{in} exceeds the desired voltage level such that the voltage at the Enable pin exceeds the Enable threshold, 1.2V, the IR3827 is turned on. The implementation of this function is shown in Figure 7.

For a typical Enable threshold of $V_{EN} = 1.2 \text{ V}$

$$PV_{in(min)} \times \frac{R_2}{R_1 + R_2} = V_{EN} = 1.2$$

$$R_2 = R_1 \times \frac{V_{EN}}{PV_{in(min)} - V_{EN}}$$

For the minimum input voltage $PV_{in(min)} = 9.2V$, select $R_1 = 49.9k\Omega$, and $R_2 = 7.5k\Omega$.

SWITCHING FREQUENCY

For $F_s = 600 \text{ kHz}$, select $R_t = 39.2 \text{ K}\Omega$, from Table 5.

OUTPUT VOLTAGE SETTING

Output voltage is set by the reference voltage and the external voltage divider connected to the FB pin. The FB pin is the inverting input of the error amplifier, which is internally referenced to 0.6V. The divider ratio is set to provide 0.6V at the FB pin when the output is at its desired value. The output voltage is defined by using the following equation:

$$V_o = V_{REF} \times \left(1 + \frac{R_{F1}}{R_{F2}}\right)$$

R_{F1} and R_{F2} are the feedback resistor divider, as shown in Figure 25. For the selection of R_{F1} and R_{F2} , please see feedback compensation section.

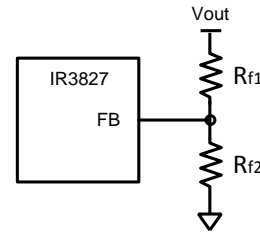


Figure 25 The output voltage is programmed through a set of feedback resistor divider

BOOTSTRAP CAPACITOR SELECTION

To drive the Control FET, it is necessary to supply a gate voltage at least 4V greater than the voltage at the SW pin, which is connected to the source of the Control FET. This is achieved by using a bootstrap configuration, which comprises the internal bootstrap diode and an external bootstrap capacitor, C1, as shown in Figure 26. The operation of the circuit is as follows: When the sync FET is turned on, the capacitor node connected to SW is pulled low. V_{CC} starts to charge C1 through the internal bootstrap diode. The voltage, V_c , across the bootstrap capacitor C1 can be calculated as

$$V_c = V_{CC} - V_D$$

where V_D is the forward voltage drop of the bootstrap diode.

When the control FET turns on in the next cycle, the SW node voltage rises to the bus voltage, PV_{in} . The voltage at the Boot pin becomes:

$$V_{BOOT} = PV_{in} + V_{CC} - V_D$$

A good quality ceramic capacitor of $0.1\mu F$ with voltage rating of at least 25V is recommended for most applications.

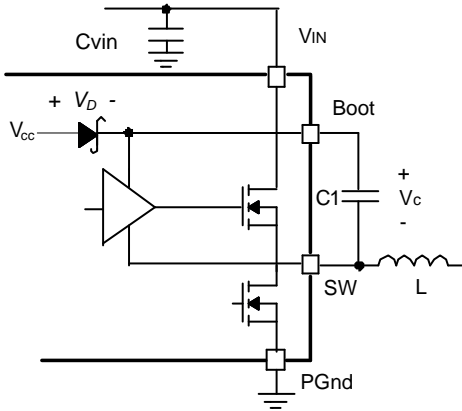


Figure 26 Bootstrap circuit to generate the supply voltage for the high-side driver voltage

INPUT CAPACITOR SELECTION

Good quality input capacitors are necessary to minimize the input ripple voltage and to supply the switch current during the on-time. The input capacitors should be selected based on the RMS value of the input ripple current and requirement of the input ripple voltage.

The RMS value of the input ripple current can be calculated as follows:

$$I_{RMS} = I_o \times \sqrt{D \times (1-D)}$$

Where D is the duty cycle and I_o is the output current. For $I_o=6A$ and $D=0.1$, $I_{RMS}= 1.8A$

The input voltage ripple is the result of the charging of the input capacitors and the voltage induced by ESR and ESL of the input capacitors.

Ceramic capacitors are recommended due to their high ripple current capabilities. They also feature low ESR and ESL at higher frequency which enables better efficiency.

For this application, it is suggested to use three 10 μ F/25V ceramic capacitors, C3216X5R1E106M, from TDK. In addition, although not mandatory, a 1x330uF, 25V SMD capacitor EEV-FK1E331P from Panasonic may also be used as a bulk capacitor and is recommended if the input power supply is not located close to the converter.

INDUCTOR SELECTION

The inductor is selected based on output power, operating frequency and efficiency requirements. A low inductor value causes large ripple current, resulting in the smaller size, faster response to a load transient but poor efficiency and high output noise. Generally, the selection of the inductor value can be reduced to the desired maximum ripple current in the inductor (Δi). The optimum point is usually found between 20% and 50% ripple of the output current.

The saturation current of the inductor is desired to be higher than the over current limit plus the inductor ripple current. An inductor with soft-saturation characteristic is recommended.

For the buck converter, the inductor value for the desired operating ripple current can be determined using the following relation:

$$PV_{in\max} - V_o = L \times \frac{\Delta i_{L\max}}{\Delta t}; \Delta t = \frac{D}{F_s}$$

$$L = (PV_{in\max} - V_o) \times \frac{V_o}{V_{in} \times \Delta i_{L\max} \times F_s}$$

Where:

$PV_{in\max}$ = Maximum input voltage

V_o = Output Voltage

$\Delta i_{L\max}$ = Maximum Inductor Peak-to-Peak Ripple Current

F_s = Switching Frequency

Δt = On time

D = Duty Cycle

Select $\Delta i_{L\max} \approx 30\% \times I_o$, then the output inductor is calculated to be 1.0 μ H. Select L=1.0 μ H, SPM6550T-1R0M, from TDK which provides a compact, low profile inductor suitable for this application.

OUTPUT CAPACITOR SELECTION

Output capacitors are usually selected to meet two specific requirements: (1) Output ripple voltage and (2) load transient response. The load transient response is also greatly affected by the control bandwidth. So it is common practice to select the output capacitors to meet the requirements of the

output ripple voltage first, and then design the control bandwidth to meet the transient load response. For some cases, even with the highest allowable control bandwidth, the resulting load transient response still cannot meet the requirement. The number of output capacitors then need to be increased.

The voltage ripple is attributed by the ripple current charging the output capacitors, and the voltage drop due to the Equivalent Series Resistance (ESR) and the Equivalent Series Inductance (ESL). Following lists the respective peak-to-peak ripple voltages:

$$\Delta V_{o(C)} = \frac{\Delta i_{Lmax}}{8 \times C_o \times F_s}$$

$$\Delta V_{o(ESR)} = \Delta i_{Lmax} \times ESR$$

$$\Delta V_{o(ESL)} = \left(\frac{PV_{in} - V_o}{L} \right) \times ESL$$

Where Δi_{Lmax} is maximum inductor peak-to-peak ripple current.

Good quality ceramic capacitors are recommended due to their low ESR, ESL and the small package size. It should be noted that the capacitance of ceramic capacitors are usually de-rated with the DC and AC biased voltage. It is important to use the de-rated capacitance value for the calculation of output ripple voltage as well as the voltage loop compensation design. The de-rated capacitance value may be obtained from the manufacturer's datasheets.

In this case, three 22uF ceramic capacitors, C2012X5R0J226M, from TDK are used to achieve $\pm 12mV$ peak-to-peak ripple voltage requirement. The de-rated capacitance value with 1.2VDC bias and 10mVAC voltage is around 18uF each.

FEEDBACK COMPENSATION

For this design, the resonant frequency of the output LC filter, F_{LC} , is

$$F_{LC} = \frac{1}{2 \times \pi \sqrt{L_o \times C_o}}$$

$$= \frac{1}{2 \times \pi \sqrt{1.0 \times 10^{-6} \times 3 \times 18 \times 10^{-6}}}$$

$$= 21.6kHz$$

The equivalent ESR zero of the output capacitors, F_{ESR} , is.

$$F_{ESR} = \frac{1}{2\pi \times \frac{ESR}{3} \times 3 \times C_o}$$

$$= \frac{1}{2\pi \times 3 \times 10^{-3} \times 18 \times 10^{-6}}$$

$$= 2.95 \times 10^3 kHz$$

Select crossover frequency $F_0=100kHz$

According to Table 1, Type III B compensation is selected for $F_{LC} < F_0 < F_s/2 < F_{ESR}$. Type III compensator is shown below for easy reference.

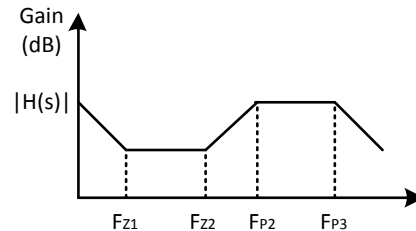
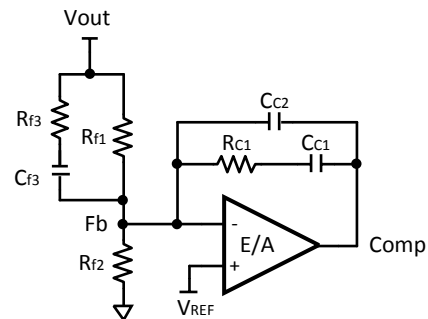


Figure 27 Type III compensation and its asymptotic gain plot

$$F_{Z1} = \frac{1}{2\pi \times R_{C1} \times C_{C1}}$$

$$F_{Z2} = \frac{1}{2\pi \times C_{F3} \times (R_{F3} + R_{F1})}$$

$$F_{P1} = 0$$

$$F_{P2} = \frac{1}{2\pi \times R_{F3} \times C_{F3}}$$

$$F_{P3} = \frac{1}{2\pi \times R_{C1} \times C_{C2}}$$

F_{Z2} and F_{P2} are selected to achieve phase boost $\Theta=70^\circ$.

$$F_{Z2} = F_0 \sqrt{\frac{1 - \sin \theta}{1 + \sin \theta}} = 100 \times 10^3 \sqrt{\frac{1 - \sin 70}{1 + \sin 70}} = 17.6 \text{kHz}$$

$$F_{P2} = F_0 \sqrt{\frac{1 + \sin \theta}{1 - \sin \theta}} = 100 \times 10^3 \sqrt{\frac{1 + \sin 70}{1 - \sin 70}} = 568 \text{kHz}$$

F_{Z1} is selected to provide extra phase boost.

$$F_{Z1} = F_{Z2} / 2 = 8.8 \text{kHz}$$

F_{P3} is set at one half of the switching frequency to damp the switching noise.

$$F_{P3} = F_s / 2 = 300 \text{kHz}$$

The selected compensation parameters are: $R_{F1}=3.32\text{k}\Omega$, $R_{F2}=3.32\text{k}\Omega$, $R_{F3}=100\Omega$, $C_{F3}=2200\text{pF}$, $R_{C1}=2\text{k}\Omega$, $C_{C1}=10\text{nF}$, $C_{C2}=180\text{pF}$.

APPLICATION DIAGRAM

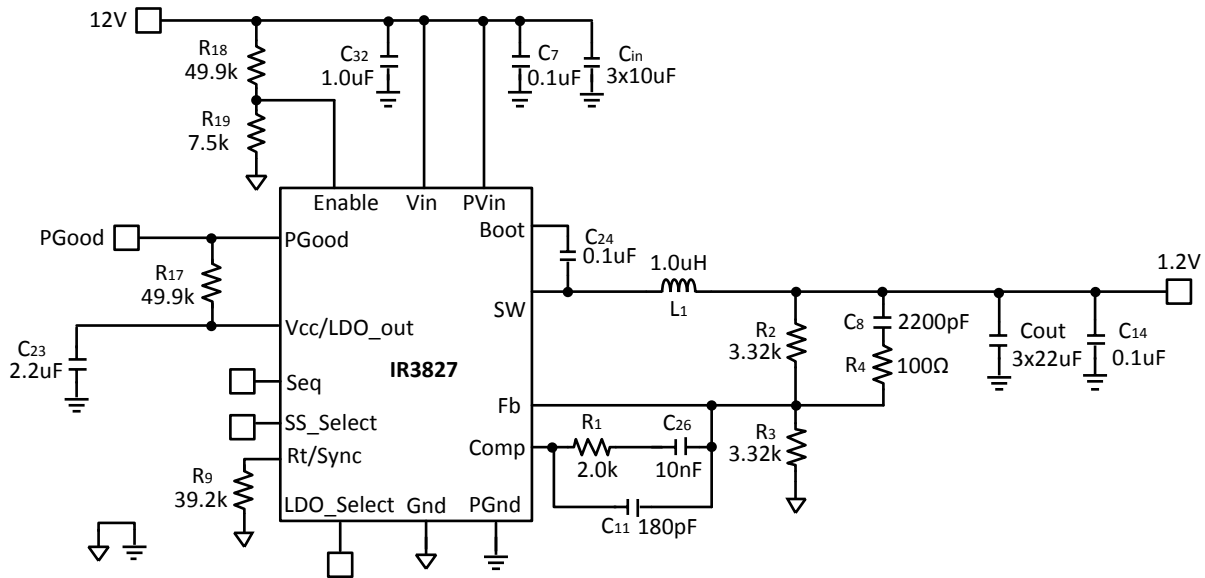


Figure 28 Single Rail 6A POL Application Circuit: $PV_{in}=V_{in}=12V$, $V_o=1.2V$, $I_o=6A$, $f_{sw}=600kHz$

SUGGESTED BILL OF MATERIALS

QTY	PART REFERENCE	VALUE	DESCRIPTION	MANUFACTURER	PART NUMBER
3	C _{in}	10uF	1206, 25V, X5R, 20%	TDK	C3216X5R1E106M
3	C7 C14 C24	0.1uF	0603, 25V, X7R, 10%	Murata	GRM188R71E104KA01B
1	C8	2200pF	0603, 50V, X7R	Murata	GRM188R71H222KA01B
1	C11	180pF	0603, 50V, NP0, 5%	Murata	GRM1885C1H181JA01D
3	C _{out}	22uF	0805, 6.3V, X5R, 20%	TDK	C2012X5R0J226M
1	C23	2.2uF	0603, 16V, X5R, 20%	TDK	C1608X5R1C225M
1	C26	10nF	0603, 25V, X7R, 10%	Murata	GRM188R71E103KA01J
1	C32	1.0uF	0603, 25V, X5R, 10%	Murata	GRM188R61E105KA12D
1	L1	1.0uH	SMD 7.1x6.5x5mm, 4.7mΩ	TDK	SPM6550T-1R0
1	R1	2K	Thick Film, 0603, 1/10W, 1%	Panasonic	ERJ-3EKF2001V
2	R2, R3	3.32K	Thick Film, 0603, 1/10W, 1%	Panasonic	ERJ-3EKF3321V
1	R4	100	Thick Film, 0603, 1/10W, 1%	Panasonic	ERJ-3EKF1000V
1	R9	39.2K	Thick Film, 0603, 1/10W, 1%	Panasonic	ERJ-3EKF3922V
2	R17 R18	49.9K	Thick Film, 0603, 1/10W, 1%	Panasonic	ERJ-3EKF4992V
1	R19	7.5K	Thick Film, 0603, 1/10W, 1%	Panasonic	ERJ-3EKF7501V
1	U1	IR3827	PQFN 4x5mm	IR	IR3827MPBF

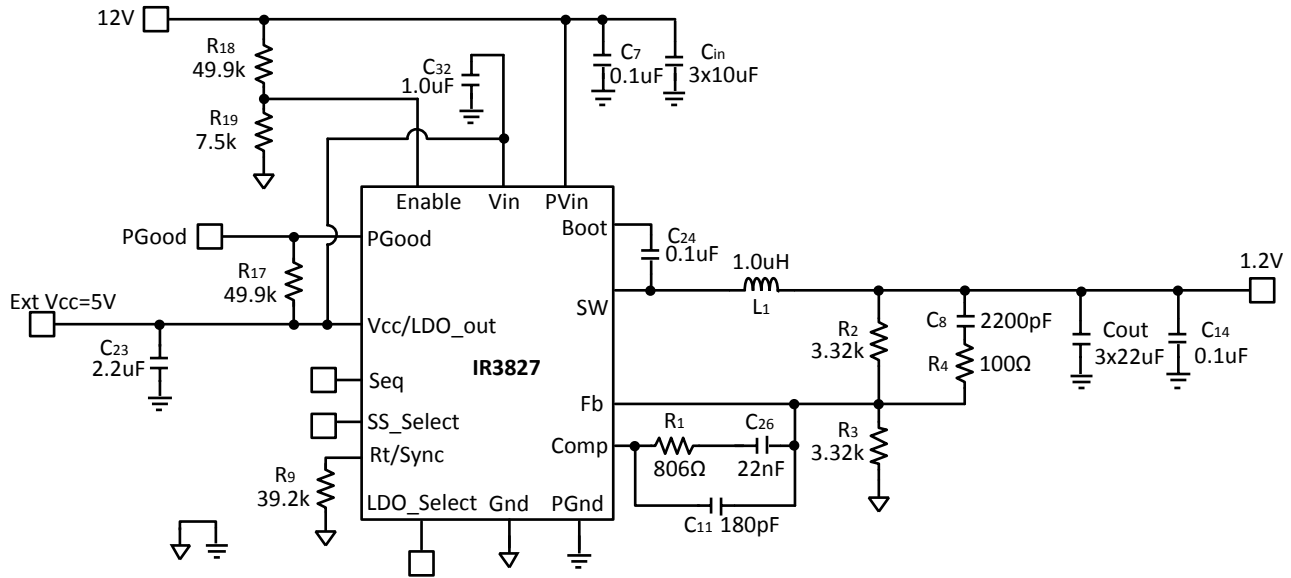
APPLICATION DIAGRAM


Figure 29 6A POL Application Circuit with external 5V V_{CC}: PV_{in}=V_{in}=12V, V_o=1.2V, I_o=6A, f_{sw}=600kHz. Please note that loop compensation is adjusted to consider the absence of the input voltage feedforward.

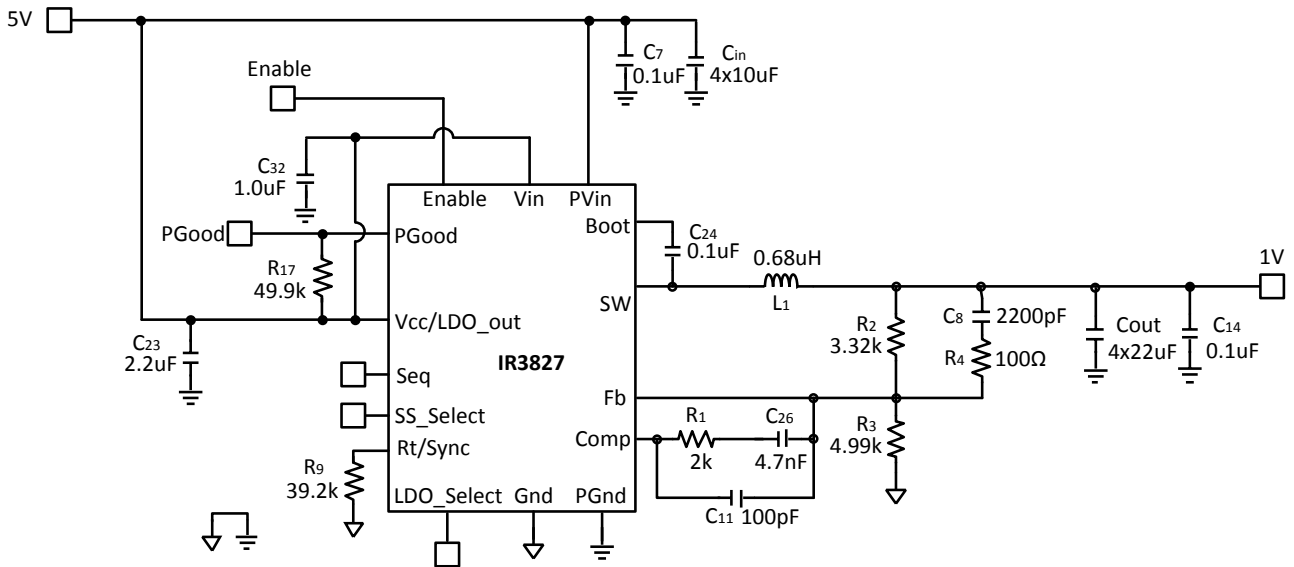


Figure 30 Single Rail 6A POL Application Circuit: PV_{in}=V_{in}=5V, V_o=1.0V, I_o=6A, f_{sw}=600kHz

TYPICAL OPERATING WAVEFORMS

$V_{in} = 12V$, $V_o = 1.2V$, $I_o = 0-6A$, Unless otherwise Specified, LDO_Select = Float. Room Temperature, No Air Flow

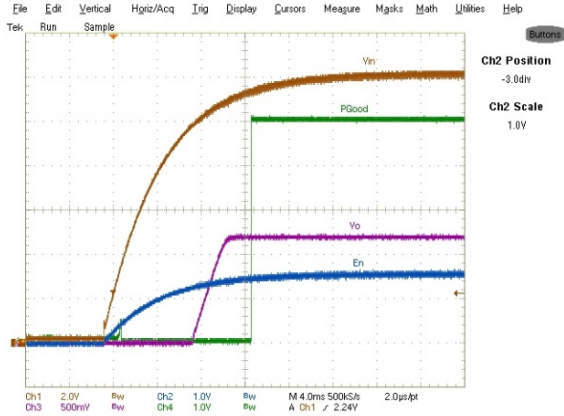


Figure 31 Start up at 6A Load with SS_Select pin floating. Ch1:V_{in}, Ch2:Enable, Ch3:V_o, Ch4: P_{Good}

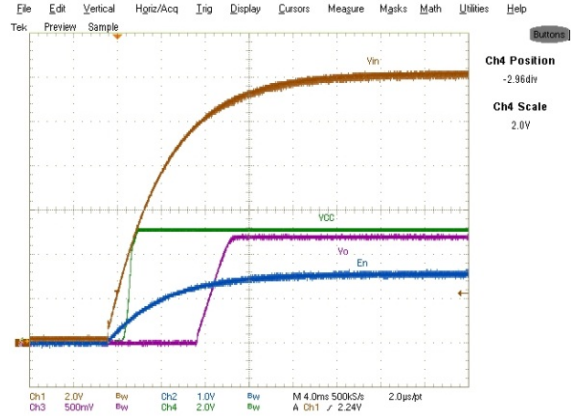


Figure 32 Start up at 6A Load with SS_Select pin floating. Ch1:V_{in}, Ch2:Enable, Ch3:V_o, Ch4:V_{CC}

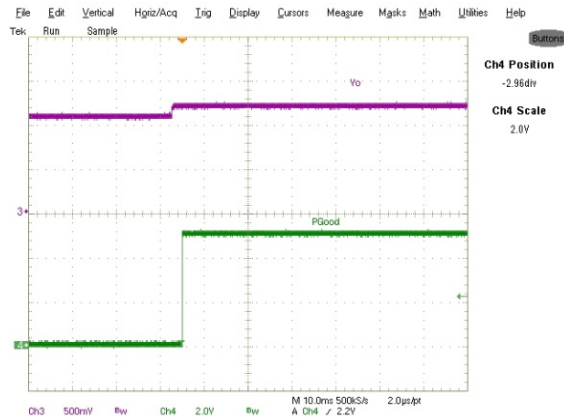


Figure 33 Start up with 1.06V Pre Bias, 0A Load Ch3: V_o, Ch4: P_{Good}

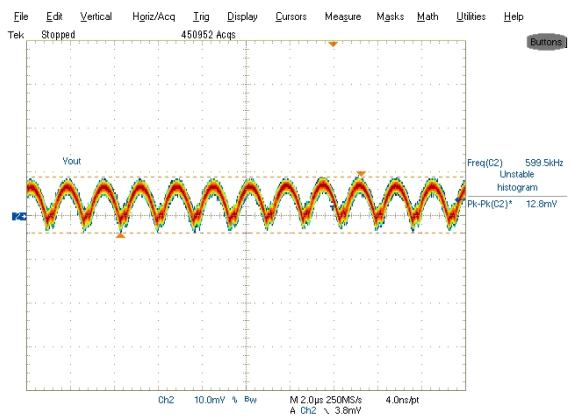


Figure 34 Output Voltage Ripple, 6A load Ch2: V_{out}

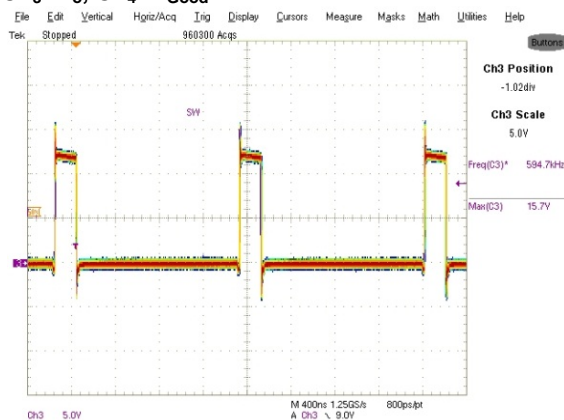


Figure 35 Inductor node at 6A load, LDO_Select = Float Ch3:LX

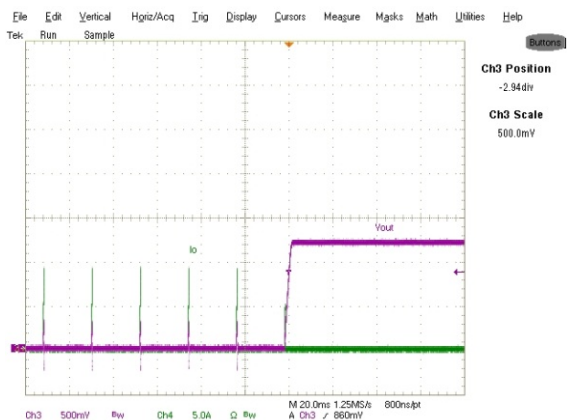


Figure 36 Short circuit (Hiccup) Recovery, SS_Select = Float, Ch3:V_{out}, Ch4:I_{out}

TYPICAL OPERATING WAVEFORMS

$V_{in} = 12V$, $V_o = 1.2V$, $I_o = 0-6A$, Unless otherwise Specified, LDO_Select = Float. Room Temperature, No Air Flow

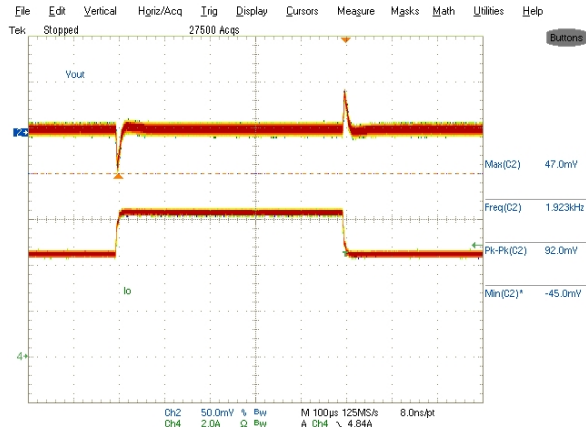


Figure 37 Transient Response, 4.2A to 6A
Step load Ch2:V_{out} Ch4:I_{out}

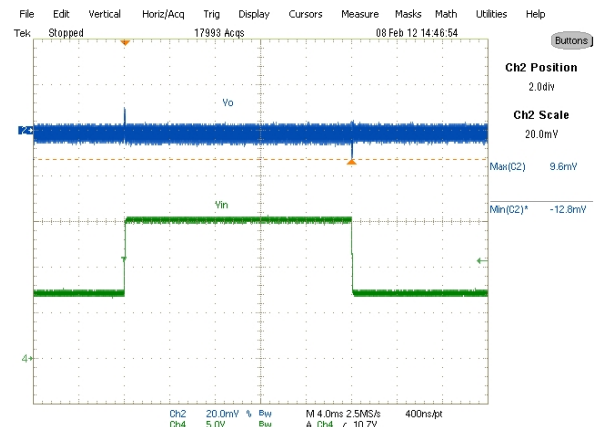
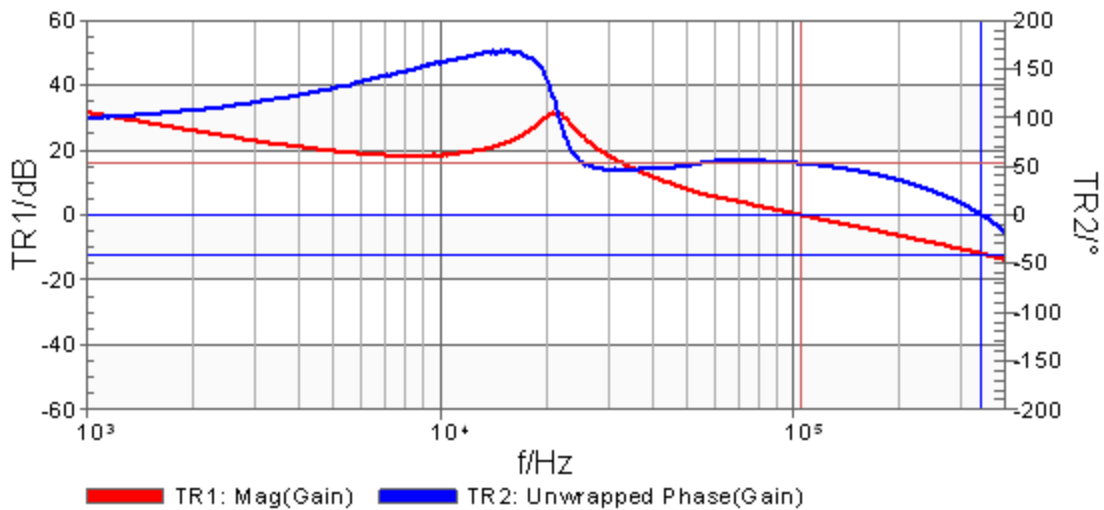


Figure 38 Feed Forward for V_{in} change
from 6.8 to 15V and back to 6.8V. Ch2-V_{out}, Ch4-V_{in}



	Frequency	Trace1	Trace2
Cursor 1	105.329 kHz	0.000 dB	53.244 °
Cursor 2	343.000 kHz	-11.966 dB	0.000 °
Delta C2-C1	237.671 kHz	-11.966 dB	-53.244 °

Figure 39 Bode Plot at 6A load, bandwidth = 105 kHz, and phase margin = 53 degrees and gain margin = -12dB

TYPICAL OPERATING WAVEFORMS

$V_{in} = 12V$, $V_o = 1.2V$, $I_o = 0-6A$, Unless otherwise Specified, LDO_Select = Float. Room Temperature, No Air Flow

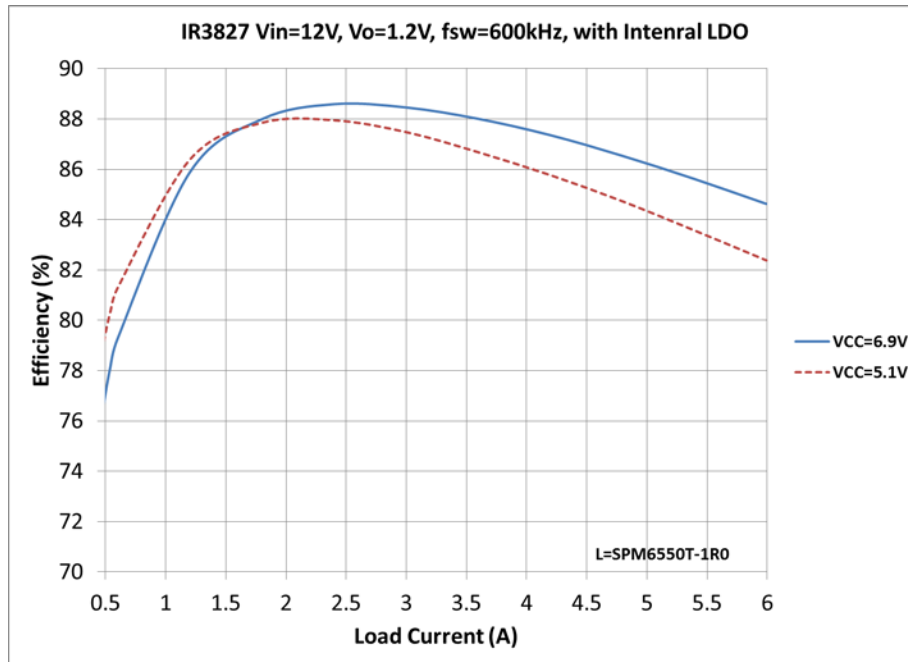


Figure 40 Efficiency vs. Load Current, LDO_Select = Gnd and Float

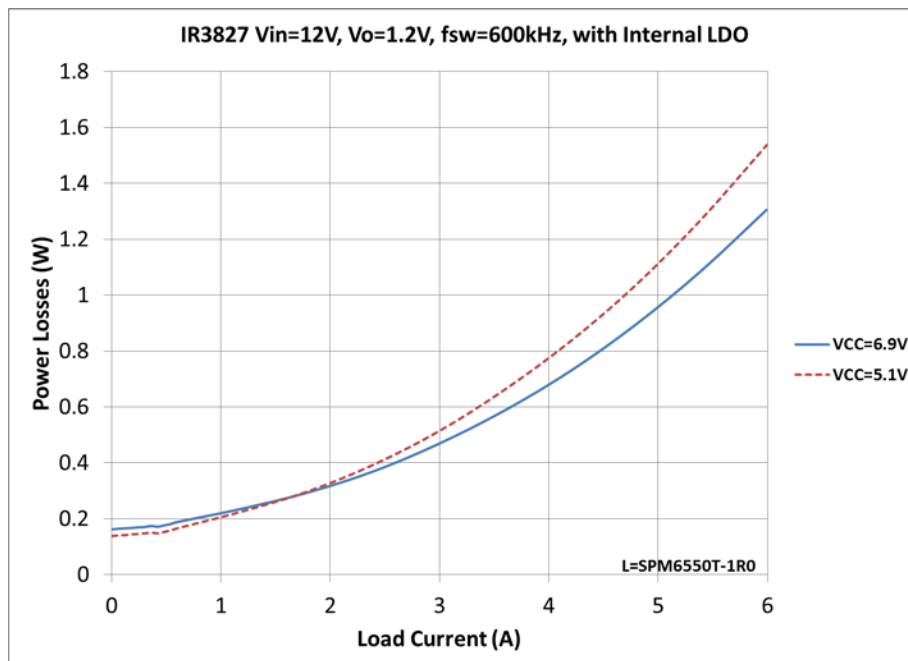


Figure 41 Power Loss vs. Load Current, LDO_Select = Gnd and Float

TYPICAL OPERATING WAVEFORMS

$V_{in} = 12V$, $V_o = 1.2V$, $I_o = 0-6A$, Unless otherwise Specified, LDO_Select = Float. Room Temperature, No Air Flow

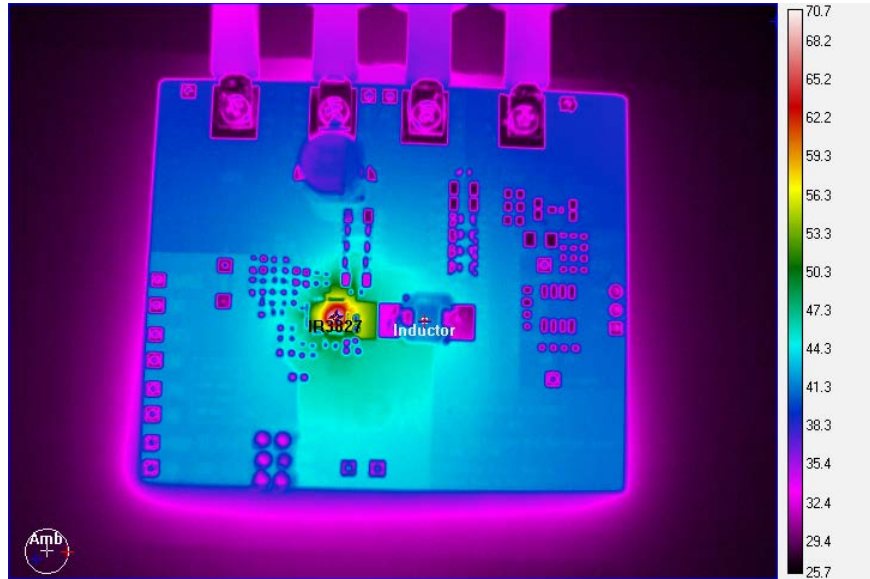


Figure 42 Thermal Image of the board at 6A load, LDO_Select= Float (VCC=5.1V)
 IR3827=70°C, Inductor=40°C

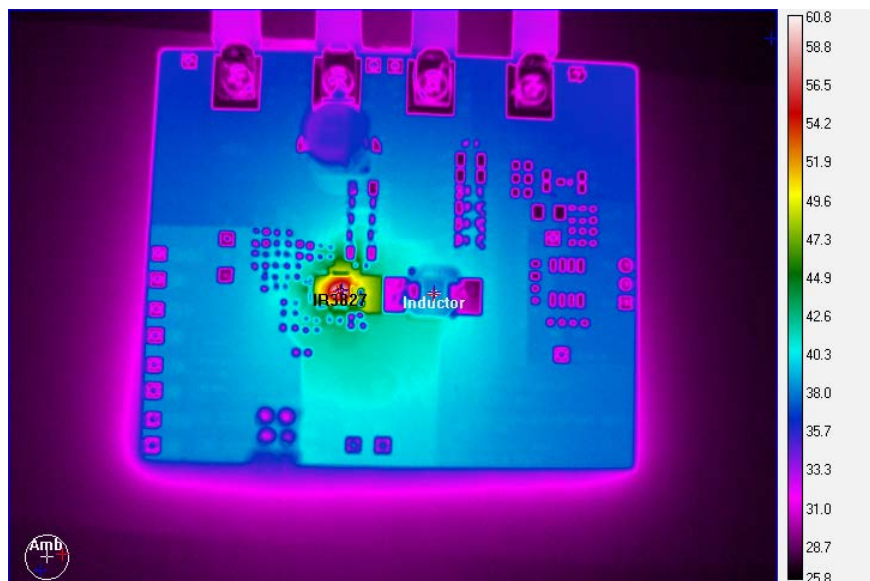


Figure 43 Thermal Image of the board at 6A load, LDO_Select= GND (VCC=6.9V)
 IR3827=60°C, Inductor=38°C

LAYOUT RECOMMENDATIONS

The layout is very important when designing high frequency switching converters. Layout will affect noise pickup and can cause a good design to perform with worse than expected results.

Make the connections for the power components in the top layer with wide, copper filled areas or polygons. In general, it is desirable to make proper use of power planes and polygons for power distribution and heat dissipation.

The inductor, output capacitors and the IR3827 should be as close to each other as possible. This helps to reduce the EMI radiated by the power traces due to the high switching currents through them. Place the input capacitor directly at the PV_{in} pin of IR3827.

The feedback part of the system should be kept away from the inductor and other noise sources.

The critical bypass components such as capacitors for V_{in} and V_{CC} should be close to their respective

pins. It is important to place the feedback components including feedback resistors and compensation components close to Fb and Comp pins.

In a multilayer PCB use one layer as a power ground plane and have a control circuit ground (analog ground), to which all signals are referenced. The goal is to localize the high current path to a separate loop that does not interfere with the more sensitive analog control function. These two grounds must be connected together on the PC board layout at a single point. It is recommended to place all the compensation parts over the analog ground plane in top layer.

The Power QFN is a thermally enhanced package. Based on thermal performance it is recommended to use at least a 4-layer PCB. To effectively remove heat from the device the exposed pad should be connected to the ground plane using via holes. Figure 44-Figure 47 illustrates the implementation of the layout guidelines outlined above, on the IRDC3827 4-layer demo board.

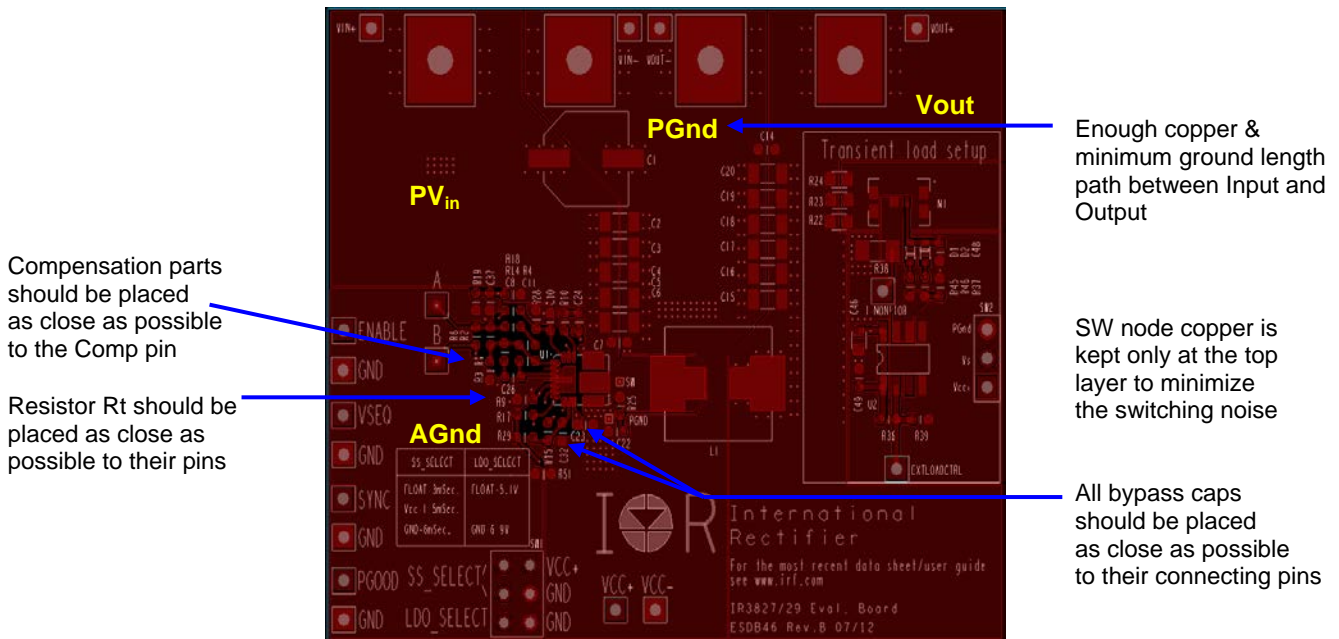


Figure 44 IRDC3827 Demo Board – Top Layer

Single point connection between AGND & PGND, should be close to the SupIRBuck kept away from noise sources

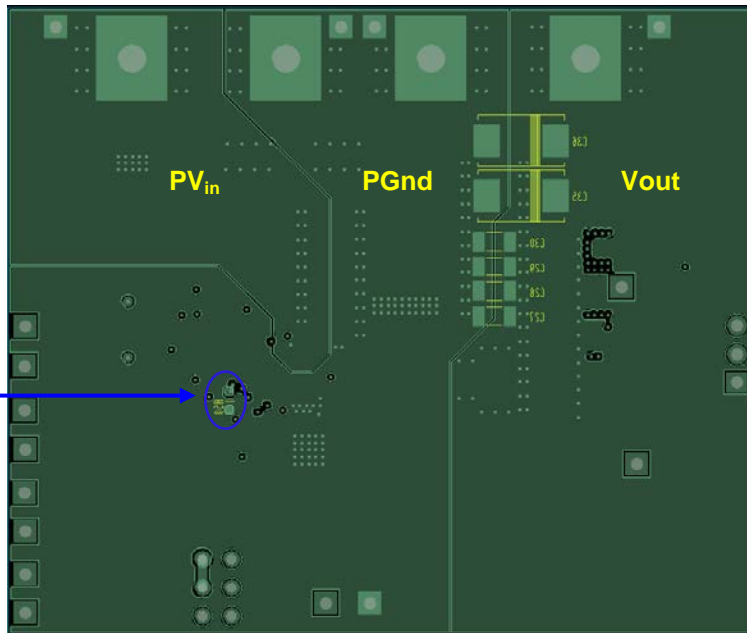


Figure 45 IRDC3827 Demo Board – Bottom Layer

Feedback and Vsns trace routing should be kept away from noise sources

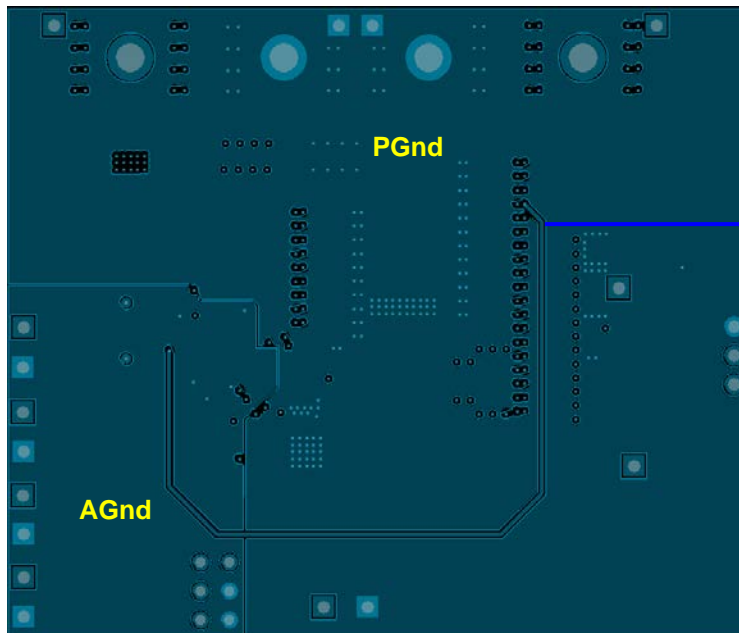


Figure 46 IRDC3827 Demo Board – Middle Layer 1

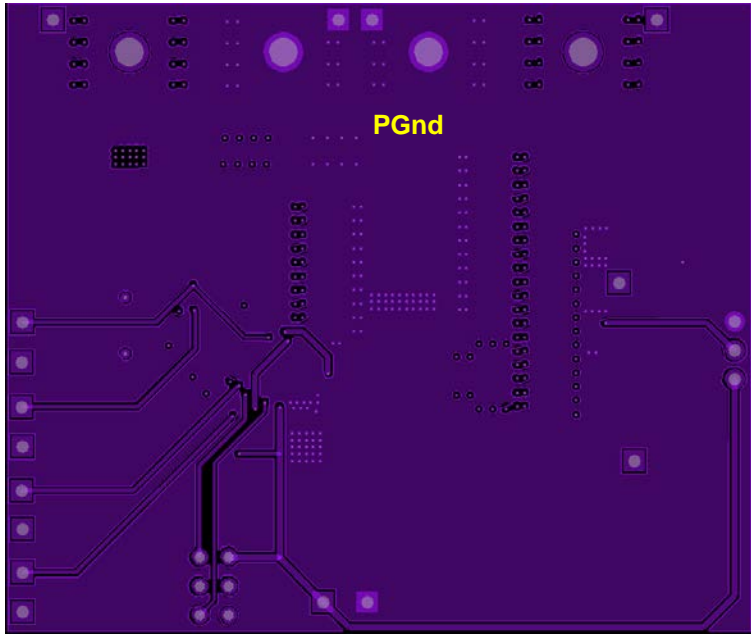


Figure 47 IRDC3827 Demo Board – Middle Layer 2

PCB METAL AND COMPONENT PLACEMENT

Evaluations have shown that the best overall performance is achieved using the substrate/PCB layout as shown in following figures. PQFN devices should be placed to an accuracy of 0.050mm on both X and Y axes. Self-centering behavior is highly

dependent on solders and processes, and experiments should be run to confirm the limits of self-centering on specific processes.

For further information, please refer to “SupIRBuck™ Multi-Chip Module (MCM) Power Quad Flat No-Lead (PQFN) Board Mounting Application Note.” (AN1132)

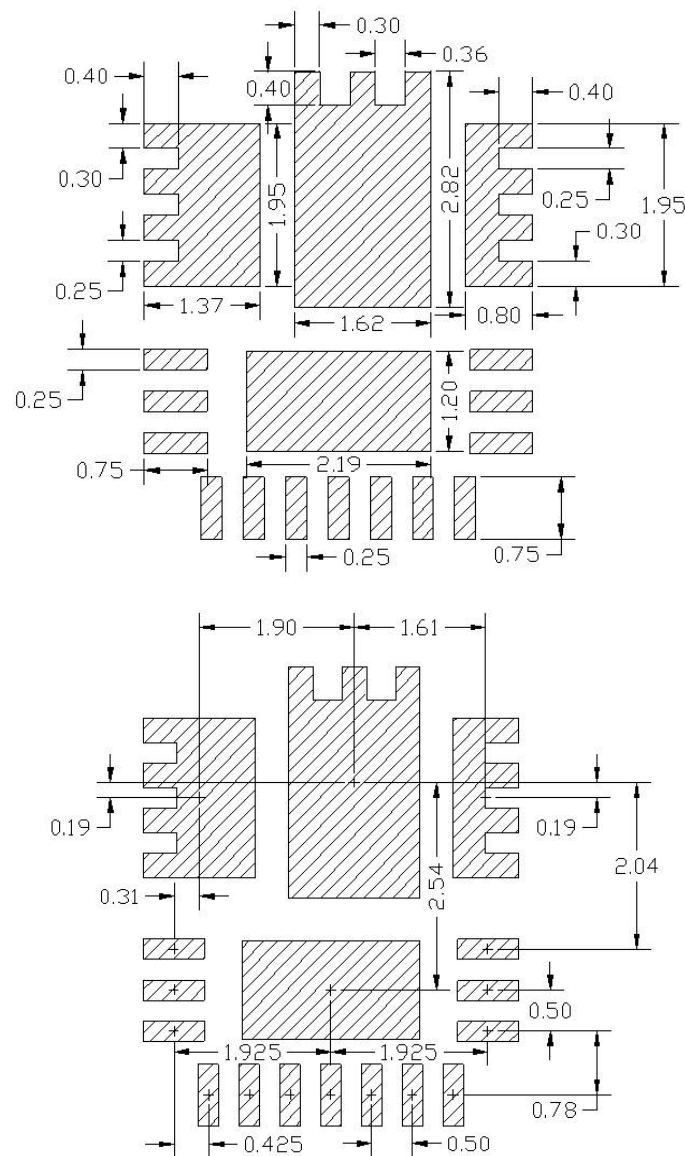


Figure 48 PCB Metal Pad Spacing (all dimensions in mm)

* Contact International Rectifier to receive an electronic PCB Library file in your preferred format

SOLDER RESIST

IR recommends that the larger Power or Land Area pads are Solder Mask Defined (SMD.) This allows the underlying Copper traces to be as large as possible, which helps in terms of current carrying capability and device cooling capability.

When using SMD pads, the underlying copper traces should be at least 0.05mm larger (on each edge) than the Solder Mask window, in order to accommodate any layer to layer misalignment. (i.e. 0.1mm in X & Y.)

However, for the smaller Signal type leads around the edge of the device, IR recommends that these

are Non Solder Mask Defined (NSMD) or Copper Defined.

When using NSMD pads, the Solder Resist Window should be larger than the Copper Pad by at least 0.025mm on each edge, (i.e. 0.05mm in X&Y,) in order to accommodate any layer to layer misalignment.

Ensure that the solder resist in-between the smaller signal lead areas are at least 0.15mm wide, due to the high x/y aspect ratio of the solder mask strip.

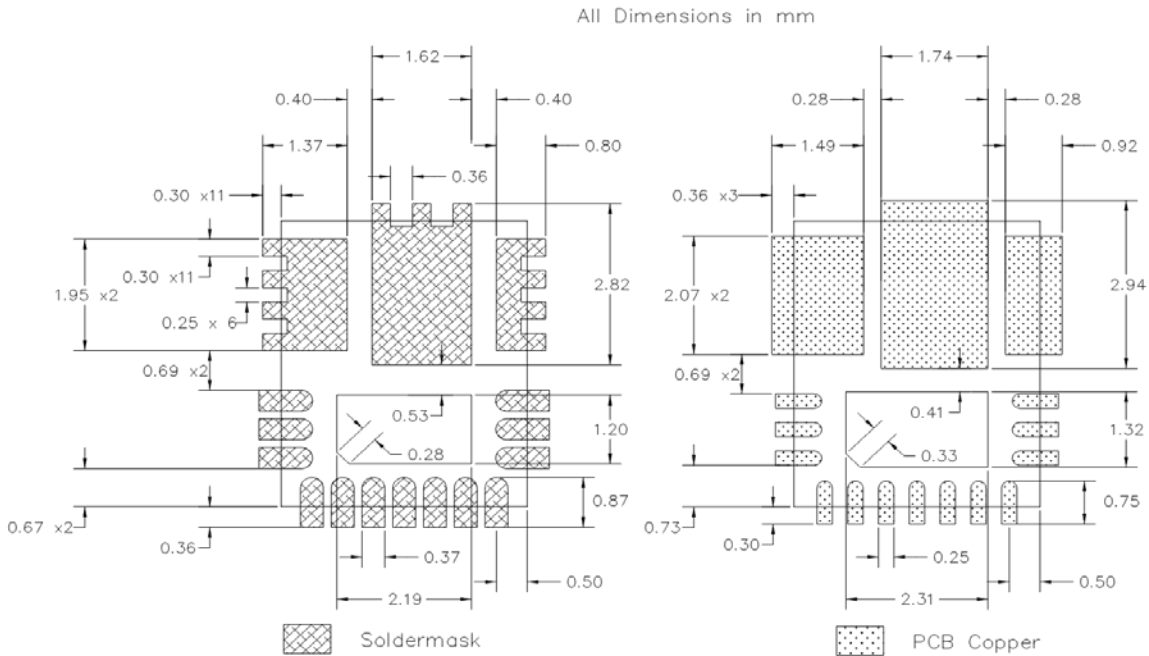


Figure 49 Solder Resist

STENCIL DESIGN

Stencils for PQFN can be used with thicknesses of 0.100-0.250mm (0.004-0.010"). Stencils thinner than 0.100mm are unsuitable because they deposit insufficient solder paste to make good solder joints with the ground pad; high reductions sometimes create similar problems. Stencils in the range of 0.125mm-0.200mm (0.005-0.008"), with suitable reductions, give the best results.

Evaluations have shown that the best overall performance is achieved using the stencil design shown in following figure. This design is for a stencil thickness of 0.127mm (0.005"). The reduction should be adjusted for stencils of other thicknesses.

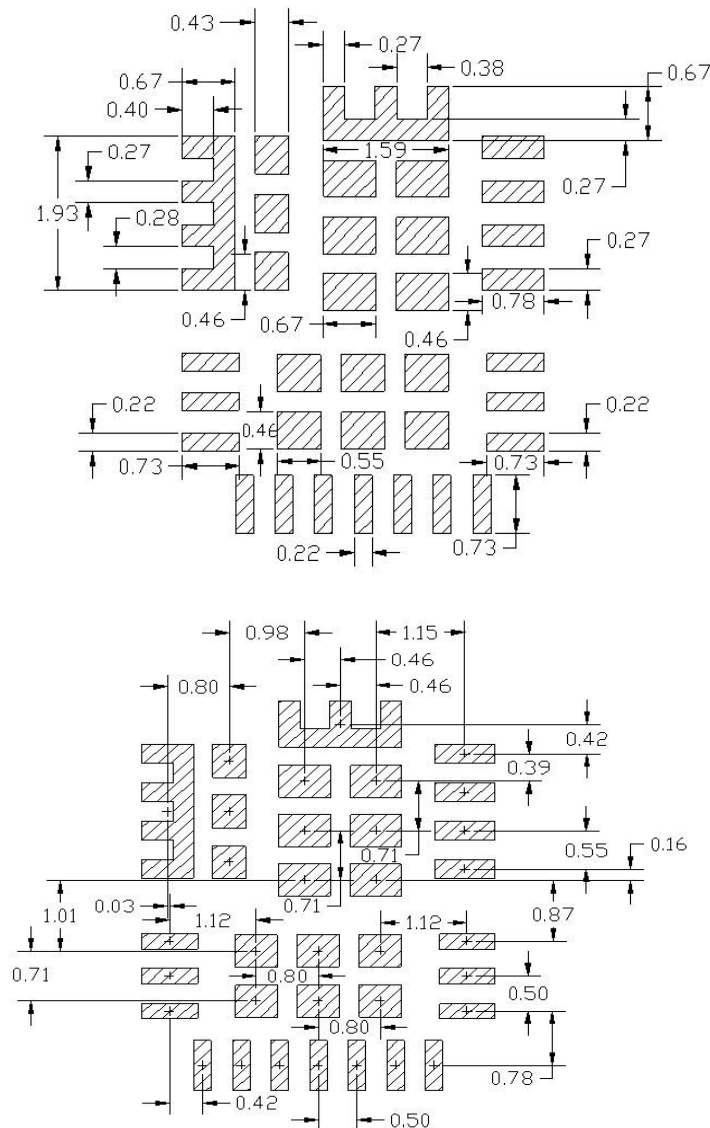
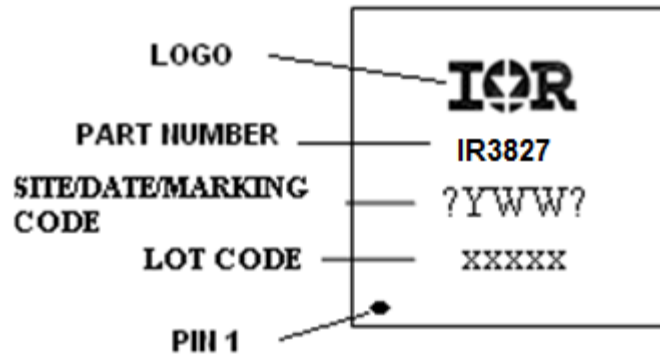
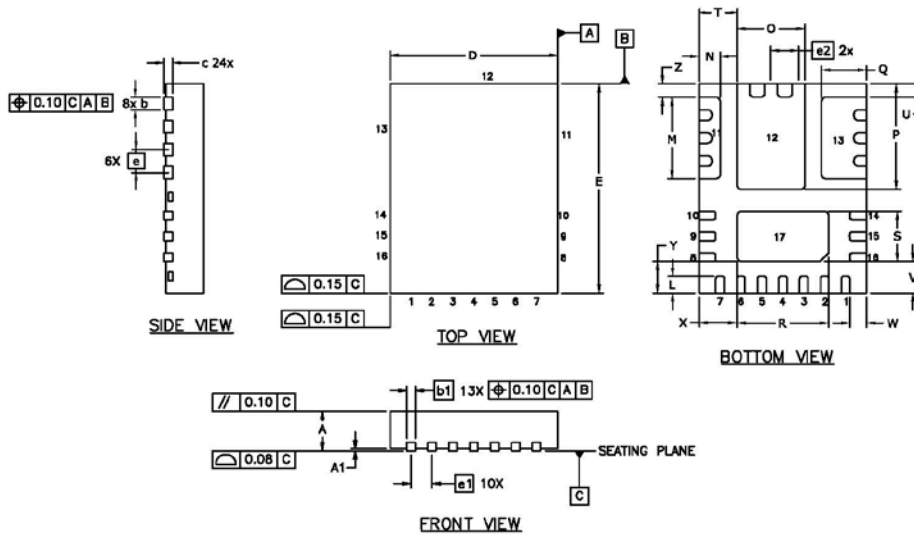


Figure 50 Stencil Pad Spacing (all dimensions in mm)

MARKING INFORMATION

PACKAGE INFORMATION


DIM	MILLIMETERS		INCHES	
	MIN	MAX	MIN	MAX
A	0.800	1.000	.0315	.0394
A1	0.000	0.050	.0000	.0020
b	0.250	0.350	.0098	.0138
b1	0.150	0.250	.0059	.0098
c	0.203 REF.		.0080 REF.	
D	4.000 BASIC		.1575 BASIC	
E	5.000 BASIC		.1969 BASIC	
e	0.550 BASIC		.0217 BASIC	
e1	0.500 BASIC		.0197 BASIC	
e2	0.659 BASIC		.0259 BASIC	
L	0.350	0.450	.0138	.0177
M	1.900	2.000	.0748	.0787
N	0.453	0.553	.0178	.0218
O	1.567	1.667	.0617	.0656
P	2.470	2.570	.0972	.1012
Q	1.024	1.124	.0403	.0443
R	2.138	2.238	.0842	.0881
S	1.150	1.250	.0453	.0492
T	0.856	0.956	.0337	.0376
U	0.270	0.370	.0106	.0146
V	0.703	0.803	.0277	.0316
W	0.350	0.450	.0138	.0177
X	0.856	0.956	.0337	.0376
Y	0.703	0.803	.0277	.0316
Z	0.270	0.370	.0106	.0146

ENVIRONMENTAL QUALIFICATIONS

Qualification Level		Industrial	
Moisture Sensitivity Level		4mm x 5mm PQFN	JEDEC Level 2 @ 260°C
ESD	Machine Model (JESD22-A115A)	Class B	
		≥200V to <400V	
	Human Body Model (JESD22-A114F)	Class 2	
		≥2000V to <4000V	
Charged Device Model (JESD22-C101D)	Class III		
	≥500V to ≤1000V		
RoHS6 Compliant		Yes	

† Qualification standards can be found at International Rectifier web site: <http://www.irf.com>

†† Exceptions to AEC-Q101 requirements are noted in the qualification report.

Data and specifications subject to change without notice.
 Qualification Standards can be found on IR’s Web site.



IR WORLD HEADQUARTERS: 233 Kansas St., El Segundo, California 90245, USA Tel: (310) 252-7105
 TAC Fax: (310) 252-7903
 Visit us at www.irf.com for sales contact information.
www.irf.com

Looking for pricing, stock, or lifecycle information?

Click below to explore more details on WIN SOURCE:

-  [View CSRN2010FK50L0 on WIN SOURCE](#)
-  [Stackpole Electronics Inc. Information](#)

Optimize Your Supply Chain with WIN SOURCE Solutions

-  Global Sourcing Solution
-  Obsolete Management
-  Cost Control Management
-  Shortage Management
-  Alternative Solution
-  Excess Inventory Management