

TVS3301 33-V Bidirectional Flat-Clamp Surge Protection Device

1 Features

- [Functional Safety-Capable](#)
 - [Documentation available to aid functional safety system design](#)
- Protection against 1-kV, 42-Ω IEC 61000-4-5 surge test for industrial signal lines
- Bidirectional polarity enables protection against bipolar signaling or miswiring conditions
- Clamping voltage of 40 V at 27-A of 8/20-μs surge current
- Standoff voltage: ±33 V
- Small 3 mm × 3 mm SON footprint
- Survives over 5,000 repetitive strikes of 25-A 8/20-μs surge current
- Robust surge protection
 - IEC61000-4-5 (8/20 μs): 27 A
 - IEC61643-321 (10/1000 μs): 3 A
- Low leakage current
 - 2.5-nA typical at 27°C
 - 450-nA maximum at 85°C
- Low capacitance: 54 pF
- Integrated level 4 IEC 61000-4-2 ESD protection

2 Applications

- [Industrial sensor I/O](#)
- [PLC I/O modules](#)
- [Analog inputs](#)
- [Appliances](#)
- [Medical equipment](#)
- [Building automation](#)

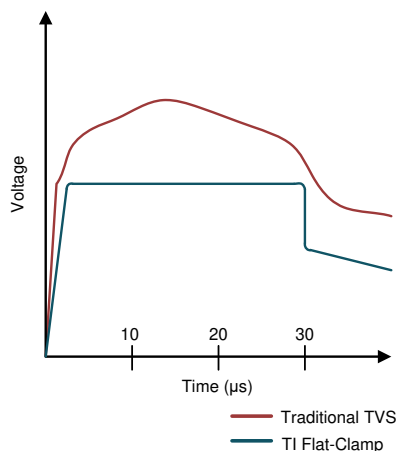

Voltage Clamp Response to 8/20-μs Surge Event

3 Description

The TVS3301 device shunts up to 27 A of IEC 61000-4-5 fault current to protect systems from high-power transients or lightning strikes. The device survives the common industrial signal line EMC requirement of 1-kV IEC 61000-4-5 open circuit voltage coupled through a 42-Ω impedance. The TVS3301 uses a feedback mechanism to ensure precise flat clamping during a fault, keeping system exposure lower than traditional TVS diodes. The tight voltage regulation allows designers to confidently select system components with a lower voltage tolerance, lowering system costs and complexity without sacrificing robustness. The TVS3301 has a ±33-V operating range to enable operation in systems that require protection against reverse wiring conditions.

In addition, the TVS3301 is available in a small SON footprint designed for space constrained applications, offering a significant size reduction compared to standard SMA and SMB packages. Low device leakage and capacitance ensure a minimal effect on the protected line. To ensure robust protection over the lifetime of the product, TI tests the TVS3301 against 5000 repetitive surge strikes at 125°C with no shift in device performance.

Package Information^{(1) (2)}

PART NUMBER	PACKAGE	BODY SIZE (NOM)
TVS3301	SON (DRB, 8)	3.00 mm × 3.00 mm

- (1) For all available packages, see the orderable addendum at the end of the data sheet.
- (2) For related products, see the [Device Comparison Table](#).

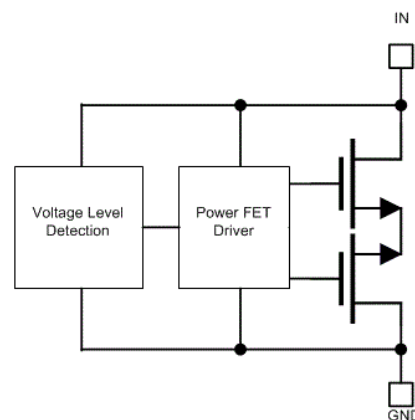

Functional Block Diagram



Table of Contents

1 Features	1	9.3 Feature Description.....	9
2 Applications	1	9.4 Device Functional Modes.....	9
3 Description	1	10 Application and Implementation	11
4 Revision History	2	10.1 Application Information.....	11
5 Description (continued)	3	10.2 Typical Application.....	11
6 Device Comparison Table	3	11 Power Supply Recommendations	13
7 Pin Configuration and Functions	4	12 Layout	13
8 Specifications	5	12.1 Layout Guidelines.....	13
8.1 Absolute Maximum Ratings.....	5	12.2 Layout Example.....	13
8.2 ESD Ratings - JEDEC.....	5	13 Device and Documentation Support	14
8.3 ESD Ratings - IEC.....	5	13.1 Documentation Support.....	14
8.4 Recommended Operating Conditions.....	5	13.2 Receiving Notification of Documentation Updates..	14
8.5 Thermal Information.....	5	13.3 Support Resources.....	14
8.6 Electrical Characteristics.....	6	13.4 Trademarks.....	14
8.7 Typical Characteristics.....	7	13.5 Electrostatic Discharge Caution.....	14
9 Detailed Description	9	13.6 Glossary.....	14
9.1 Overview.....	9	14 Mechanical, Packaging, and Orderable Information	14
9.2 Functional Block Diagram.....	9		

4 Revision History

NOTE: Page numbers for previous revisions may differ from page numbers in the current version.

Changes from Revision A (December 2018) to Revision B (September 2022)	Page
• Updated the numbering format for tables, figures, and cross-references throughout the document.....	1
• Updated the <i>Features</i> section to include Functional Safety-Capable text.....	1

Changes from Revision * (September 2018) to Revision A (December 2018)	Page
• Changed from Advance Information to Production Data	1

5 Description (continued)

The TVS3301 is part of TI's Flat-Clamp family of surge devices. For a deeper look at the Flat-Clamp family, refer to the [Flat-Clamp Surge Protection Technology for Efficient System Protection](#) white paper.

6 Device Comparison Table

DEVICE	V _{rwm}	V _{clamp} at I _{pp}	I _{pp} (8/20 μs)	Leakage at V _{rwm}	POLARITY	Package
TVS0500	5	9.2 V	43 A	0.07 nA	Unidirectional	DRV (SON-6)
TVS0701	7	11 V	30 A	0.25 nA	Bidirectional	DRB (SON-8)
TVS1400	14	18.6 V	43 A	2 nA	Unidirectional	DRV (SON-6)
TVS1401	14	20.5 V	30 A	1.1 nA	Bidirectional	DRB (SON-8)
TVS1800	18	22.8 V	40 A	0.3 nA	Unidirectional	DRV (SON-6)
TVS1801	18	27.4 V	30 A	0.4 nA	Bidirectional	DRB (SON-8)
TVS2200	22	27.7 V	40 A	3.2 nA	Unidirectional	DRV (SON-6)
TVS2201	22	29.6 V	30 A	2 nA	Bidirectional	DRB (SON-8)
TVS2700	27	32.5 V	40 A	1.7 nA	Unidirectional	DRV (SON-6)
TVS2701	27	34 V	27 A	0.8 nA	Bidirectional	DRB (SON-8)
TVS3300	33	38 V	35 A	19 nA	Unidirectional	DRV (SON-6), YZF (WCSP)
TVS3301	33	40 V	27 A	2.5 nA	Bidirectional	DRB (SON-8)

7 Pin Configuration and Functions

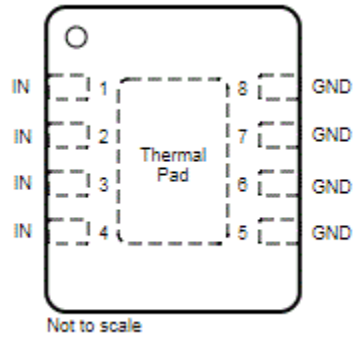

**Figure 7-1. DRB Package,
8-Pin SON
(Top View)**

Table 7-1. Pin Functions

PIN		TYPE ⁽¹⁾	DESCRIPTION
NAME	DRB		
IN	1, 2, 3, 4	IN	Surge protected channel
GND	5, 6, 7, 8	GND	Ground
FLOAT	Exposed Thermal Pad	NC	Exposed thermal pad must be floating.

(1) IN = input, GND = ground, NC = no connection.

8 Specifications

8.1 Absolute Maximum Ratings

$T_A = 27^\circ\text{C}$ (unless otherwise noted)⁽¹⁾

		MIN	MAX	UNIT
Maximum Surge	IEC 61000-4-5 Current (8/20 μs)		± 27	A
	IEC 61000-4-5 Power (8/20 μs)		1100	W
	IEC 61643-321 Current (10/1000 μs)		± 3	A
	IEC 61643-321 Power (10/1000 μs)		120	W
EFT	IEC 61000-4-4 EFT Protection		± 80	A
I_{BR}	DC Current		20	mA
T_A	Ambient Operating Temperature	-40	125	$^\circ\text{C}$
T_{stg}	Storage Temperature	-65	150	$^\circ\text{C}$

- (1) Stresses beyond those listed under *Absolute Maximum Rating* may cause permanent damage to the device. These are stress ratings only, which do not imply functional operation of the device at these or any other conditions beyond those indicated under *Recommended Operating Condition*. Exposure to absolute-maximum-rated conditions for extended periods may affect device reliability.

8.2 ESD Ratings - JEDEC

			VALUE	UNIT
$V_{(ESD)}$	Electrostatic discharge	Human body model (HBM), per ANSI/ESDA/JEDEC JS-001, all pins ⁽¹⁾	± 2000	V
		Charged device model (CDM), per JEDEC specification JESD22-C101, all pins ⁽²⁾	± 500	

- (1) JEDEC document JEP155 states that 500-V HBM allows safe manufacturing with a standard ESD control process.
(2) JEDEC document JEP157 states that 250-V CDM allows safe manufacturing with a standard ESD control process.

8.3 ESD Ratings - IEC

			VALUE	UNIT
$V_{(ESD)}$	Electrostatic discharge	IEC 61000-4-2 contact discharge	± 8	kV
		IEC 61000-4-2 air-gap discharge	± 15	

8.4 Recommended Operating Conditions

over operating free-air temperature range (unless otherwise noted)

		MIN	NOM	MAX	UNIT
V_{RWM}	Reverse Stand-Off Voltage		± 33		V

8.5 Thermal Information

THERMAL METRIC ⁽¹⁾		TVS3301	UNIT
		DRB (SON)	
		8 PINS	
R_{qJA}	Junction-to-ambient thermal resistance	52.0	$^\circ\text{C}/\text{W}$
$R_{qJC(top)}$	Junction-to-case (top) thermal resistance	56.1	$^\circ\text{C}/\text{W}$
R_{qJB}	Junction-to-board thermal resistance	24.9	$^\circ\text{C}/\text{W}$
Y_{JT}	Junction-to-top characterization parameter	2.1	$^\circ\text{C}/\text{W}$
Y_{JB}	Junction-to-board characterization parameter	24.8	$^\circ\text{C}/\text{W}$
$R_{qJC(bot)}$	Junction-to-case (bottom) thermal resistance	9.8	$^\circ\text{C}/\text{W}$

- (1) For more information about traditional and new thermal metrics, see the [Semiconductor and IC Package Thermal Metrics](#) application report.

8.6 Electrical Characteristics

over operating free-air temperature range (unless otherwise noted)

PARAMETER		TEST CONDITIONS	MIN	TYP	MAX	UNIT
I _{LEAK}	Leakage Current	Measured at V _{IN} = ±V _{RWM} , T _A = 27°C		2.5	110	nA
		Measured at V _{IN} = ±V _{RWM} , T _A = 85°C			450	
V _{BR}	Break-down Voltage	I _{IN} = ±1 mA	34.4	37.5		V
V _{CLAMP}	Clamp Voltage	±I _{pp} IEC 61000-4-5 Surge (8/20 μs), V _{IN} = 0 V before surge, T _A = 27°C		40	42.5	V
		21 A IEC 61000-4-5 Surge (8/20 μs), V _{IN} = ±V _{RWM} before surge, T _A = 125°C			43.2	
R _{DYN}	8/20 μs surge dynamic resistance	Calculated from V _{CLAMP} at .5*I _{pp} and I _{pp} surge current, T _A = 25°C		35		mΩ
C _{IN}	Input pin capacitance	V _{IN} = V _{RWM} , f = 1 MHz, 30 mV _{pp} , IO to GND		54		pF
SR	Maximum Slew Rate	0-±V _{RWM} rising edge, sweep rise time and measure slew rate when I _{PEAK} = 1 mA, T _A = 27°C		2.5		V/μs
		0-±V _{RWM} rising edge, sweep rise time and measure slew rate when I _{PEAK} = 1 mA, T _A = 85°C		1.0		

8.7 Typical Characteristics

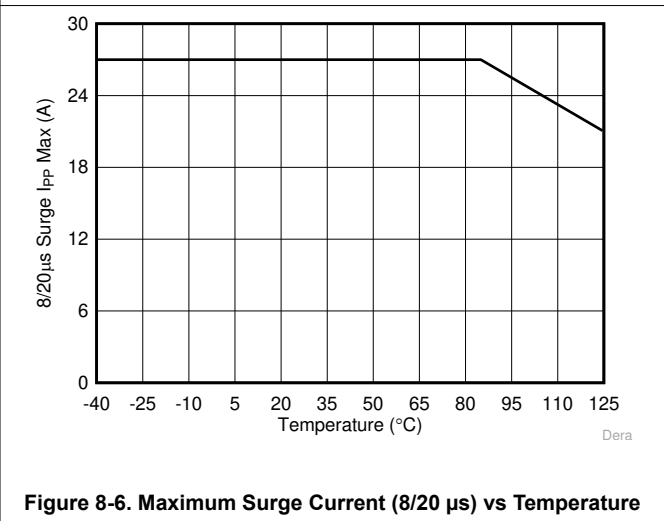
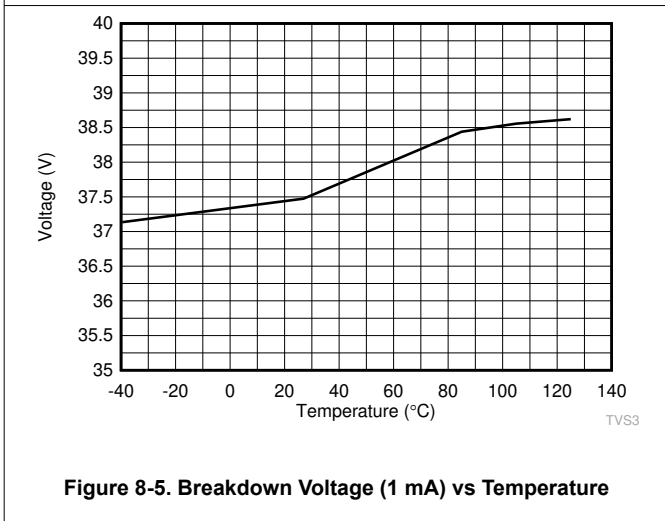
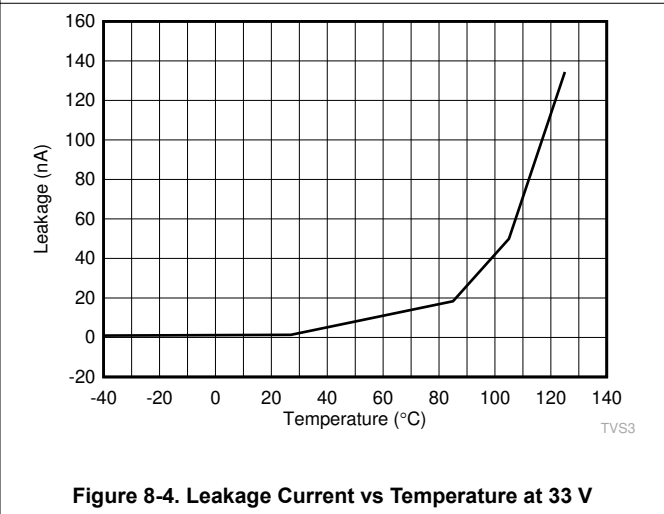
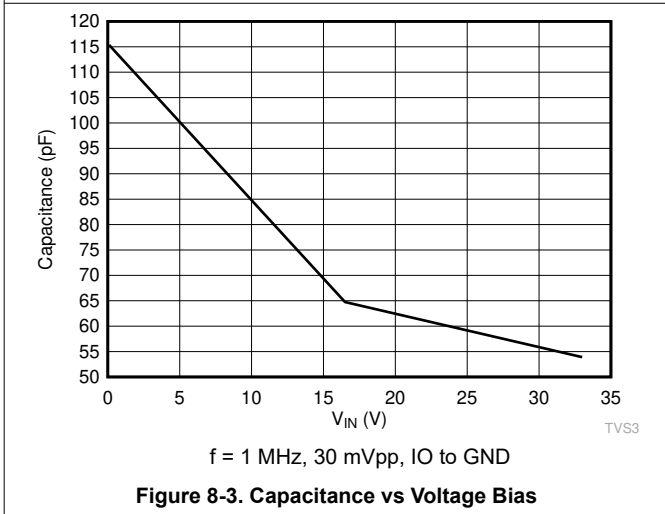
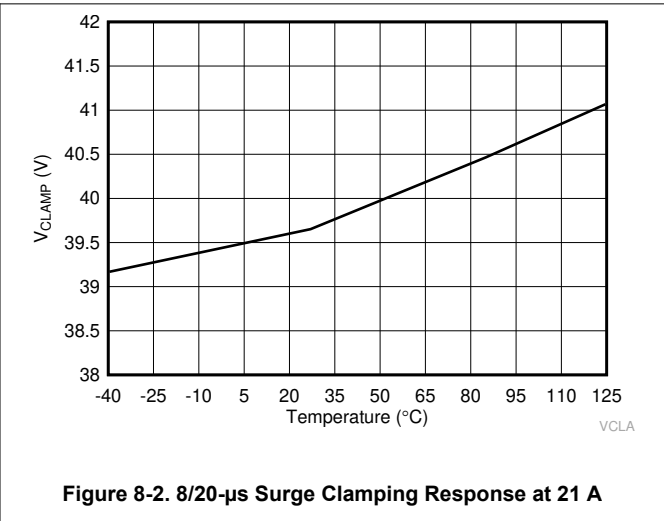
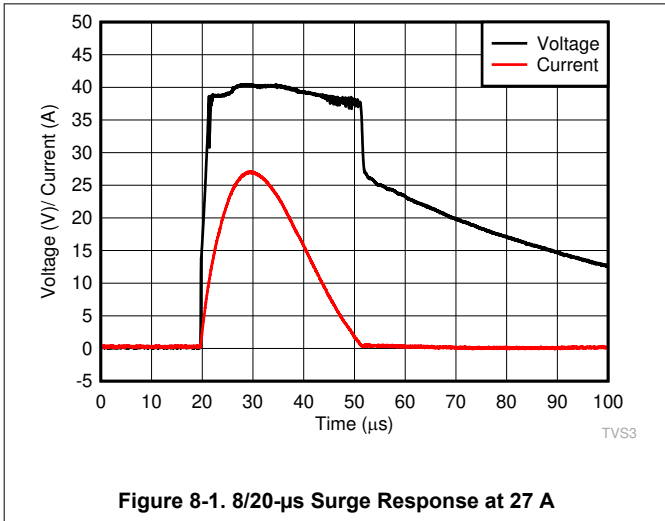

8.7 Typical Characteristics (continued)

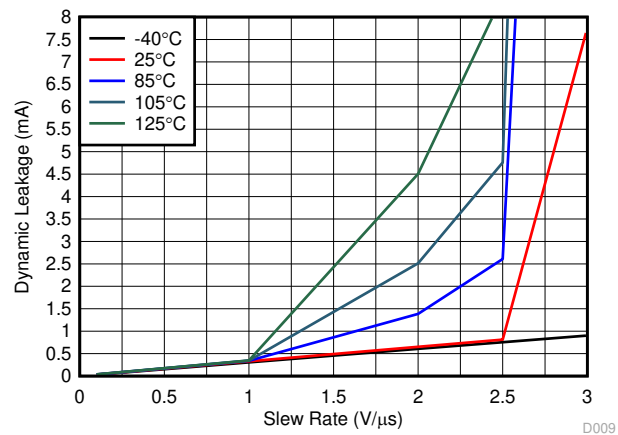

Figure 8-7. Dynamic Leakage vs Signal Slew Rate Across Temperature

9 Detailed Description

9.1 Overview

The TVS3301 is a bidirectional precision clamp with two integrated FETs driven by a feedback loop to tightly regulate the input voltage during an overvoltage event. This feedback loop leads to a very low dynamic resistance, giving a flat clamping voltage during transient overvoltage events like a surge.

9.2 Functional Block Diagram

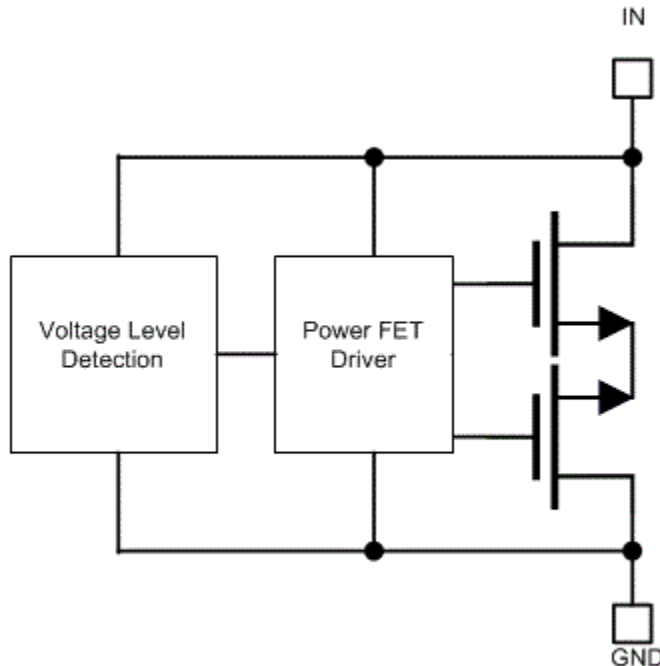

9.3 Feature Description

The TVS3301 is a precision clamp that handles 27 A of IEC 61000-4-5 8/20- μ s surge pulse. The flat clamping feature helps keep the clamping voltage very low to keep the downstream circuits from being stressed. The flat clamping feature can also help end-equipment designers save cost by opening up the possibility to use lower-cost, lower voltage tolerant downstream ICs. This device provides a bidirectional operating range, with a symmetrical V_{RWM} of ± 33 V designed for applications that have bipolar input signals or that must withstand reverse wiring conditions. The TVS3301 has minimal leakage at V_{RWM} , designed for applications where low leakage and power dissipation is a necessity. Built-in IEC 61000-4-2 and IEC 61000-4-4 ratings make it a robust protection solution for ESD and EFT events and the TVS3301 wide ambient temperature range of -40°C to $+125^{\circ}\text{C}$ enables usage in harsh industrial environments.

9.4 Device Functional Modes

9.4.1 Protection Specifications

The TVS3301 is specified according to both the IEC 61000-4-5 and IEC 61643-321 standards. This enables usage in systems regardless of which standard is required by relevant product standards or best matches measured fault conditions. The IEC 61000-4-5 standard requires protection against a pulse with a rise time of 8 μ s and a half-length of 20 μ s, while the IEC 61643-321 standard requires protection against a much longer pulse with a rise time of 10 μ s and a half-length of 1000 μ s.

The positive and negative surges are imposed to the TVS3301 by a combination wave generator (CWG) with a 2- Ω coupling resistor at different peak voltage levels. For powered-on transient tests that need power supply bias, inductances are used to decouple the transient stress and protect the power supply. The TVS3301 is post-tested by assuring that there is no shift in device breakdown or leakage at V_{RWM} .

In addition, the TVS3301 has been tested according to IEC 61000-4-5 to pass a ± 1 -kV surge test through a 42- Ω coupling resistor and a 0.5- μ F capacitor. This test is a common test requirement for industrial signal I/O lines and the TVS3301 precision clamp can be used in applications that have that requirement.

The TVS3301 integrates IEC 61000-4-2 level 4 ESD Protection and 80 A of IEC 61000-4-4 EFT Protection. These combine to ensure that the device can protect against most common transient test requirements.

For more information on TI's test methods for Surge, ESD, and EFT testing, refer to the [IEC 61000-4-x Tests for TI's Protection Devices](#) application report.

9.4.2 Reliability Testing

To ensure device reliability, the TVS3301 is characterized against 5000 repetitive pulses of 25-A IEC 61000-4-5 8/20- μ s surge pulses at 125°C. The test is performed with less than 10 seconds between each pulse at high temperature to simulate worst-case scenarios for fault regulation. After each surge pulse, the TVS3301 clamping voltage, breakdown voltage, and leakage are recorded to ensure that there is no variation or performance degradation. By ensuring robust, reliable, high temperature protection, the TVS3301 enables fault protection in applications that must withstand years of continuous operation with no performance change.

9.4.3 Minimal Derating

Unlike traditional diodes, the TVS3301 has very little derating of maximum power dissipation and ensures robust performance up to 125°C, shown in [Figure 8-6](#). Traditional TVS diodes lose up to 50% of their current carrying capability when at high temperatures, so a surge pulse above 85°C ambient can cause failures that are not seen at room temperature. The TVS3301 prevents this so the designer can see the surge protection regardless of temperature. Because of this, Flat-Clamp devices can provide robust protection against surge pulses that occur at high ambient temperatures, as shown in TI's [TVS Surge Protection in High-Temperature Environments](#) application report.

9.4.4 Bidirectional Operation

The TVS3301 is a bidirectional TVS with a symmetrical operating region. This allows for operation with positive and negative voltages, rather than just positive voltages like the unidirectional TVS3300. This allows for single chip protection for applications where the signal is expected to operate below 0 V or where there is a need to withstand a large common-mode voltage. In addition, there is a system requirement to be able to withstand reverse wiring conditions, in many cases where a high voltage signal is accidentally applied to the system ground and a ground is accidentally applied to the input terminal. This causes a large reverse voltage on the TVS diode that the device must be able to withstand. The TVS3301 is designed to not break down or see failures under reverse wiring conditions for applications that must withstand these miswiring issues.

Note

If the applied signal is not expected to go below 0 V, a unidirectional device will clamp much lower in the reverse direction and should be used. In this case, the recommended device would be the TVS3300.

9.4.5 Transient Performance

During large transient swings, the TVS3301 will begin clamping the input signal to protect downstream conditions. While this prevents damage during fault conditions, it can cause leakage when the intended input signal has a fast slew rate. To keep power dissipation low and remove the chance of signal distortion, TI recommends that the designer keep the slew rate of any input signal on the TVS3301 below 2.5 V/ μ s at room temperature and below 1.0 V/ μ s at 85°C shown in [Figure 8-7](#). Faster slew rates will cause the device to clamp the input signal and draw current through the device for a few microseconds, increasing the rise time of the signal. This will not cause any harm to the system or to the device, however, it can cause device overheating if the fast input voltage swings occur regularly.

10.2.1 Design Requirements

A typical operation for the TVS3301 would be protecting an analog output module on a PLC similar to [Figure 10-2](#). In this example, the TVS3301 is protecting a 4-20 mA transmitter that uses the XTR115, a standard transmitter that has a nominal voltage of 24 V and a maximum input voltage of 40 V. Most industrial interfaces such as this require protection against ± 1 kV surge test through a 42- Ω coupling resistor and a 0.5- μ F capacitor, equaling roughly 24 A of surge current. The system also requires protection from reverse wiring conditions. Without any input protection, this input voltage will rise to hundreds of volts for multiple microseconds, and violate the absolute maximum input voltage and harm the device if a surge event is caused by lightning, coupling, ringing, or any other fault condition. TI's Flat-Clamp technology provides surge protection diodes that can maximize the useable voltage range and clamp at a safe level for the system.

10.2.2 Detailed Design Procedure

If the TVS3301 is in place to protect the device, the voltage will rise to the breakdown of the diode at 37.5 V, during a surge event. The TVS3301 will then turn on to shunt the surge current to ground. With the low dynamic resistance of the TVS3301, large amounts of surge current will have minimal impact on the clamping voltage. The dynamic resistance of the TVS3301 is around 35 m Ω , which means a 24-A surge current will cause a voltage raise of $24 \text{ A} \times 35 \text{ m}\Omega = 0.84 \text{ V}$. Because the device turns on at 37.5 V, this means the XTR115 input will be exposed to a maximum of $37.5 \text{ V} + 0.84 \text{ V} = 38.34 \text{ V}$ during surge pulses, well within the absolute maximum input voltage to ensure robust protection of the circuit.

Because the TVS3301 is a bidirectional device, it also satisfies the condition for withstanding reverse wiring. In this case, if V_{LOOP} is wired in reverse, the input terminal of the TVS3301 will see -24 V , which is below the negative V_{RWM} . The leakages will be the same as if the battery is wired properly.

The small size of the device also improves fault protection by lowering the effect of fault current coupling onto neighboring traces. The small form factor of the TVS3301 allows the device to be placed extremely close to the input connector, which lowers the length of the path fault current going through the system compared to larger protection solutions. Finally, the low leakage of the TVS3301 will have low input power losses. At 33 V, the device will see typical 2.5-nA leakage for a constant power dissipation of less than 100 μ W, a small quantity that will minimally effect overall efficiency metrics and heating concerns.

10.2.3 Application Curves

As shown in [Figure 10-3](#), the TVS3301 will clamp when exposed to a surge.

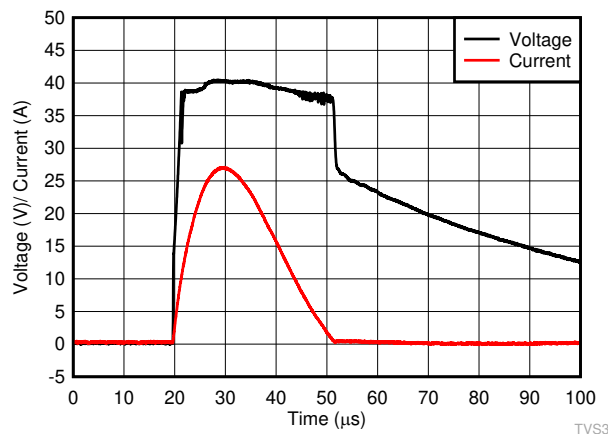

Figure 10-3. TVS3301 Clamping Waveform (27-A, 8/20- μ s Surge)

10.2.4 PLC Surge Protection Reference Design

For a detailed description of the Flat-Clamp devices advantages in a PLC Analog Input Module, reference TI's [Surge Protection Reference Design for PLC Analog Input Module](#). This document describes the considerations and performance of the TVS3300 in a common industrial application. While the document does not reference the TVS3301 specifically, performance between the devices should be similar.

11 Power Supply Recommendations

The TVS3301 is a clamping device so there is no need to power it. To ensure the device functions properly do not violate the recommended V_{IN} voltage range (–33 V to 33 V).

12 Layout

12.1 Layout Guidelines

The optimum placement is close to the connector. EMI during an ESD event can couple from the tested trace to other nearby unprotected traces, which could result in system failures. The PCB designer must minimize the possibility of EMI coupling by keeping all unprotected traces away from protected traces between the TVS and the connector. Route the protected traces straight. Use rounded corners with the largest radii possible to eliminate any sharp corners on the protected traces between the TVS3301 and the connector. Electric fields tend to build up on corners, which could increase EMI coupling.

Ensure that the thermal pad on the layout is floating rather than grounded. Grounding the thermal pad will impede the operating range of the TVS3301, and can cause failures when the applied voltage is negative. A floating thermal pad allows the maximum operating range without sacrificing any transient performance.

12.2 Layout Example

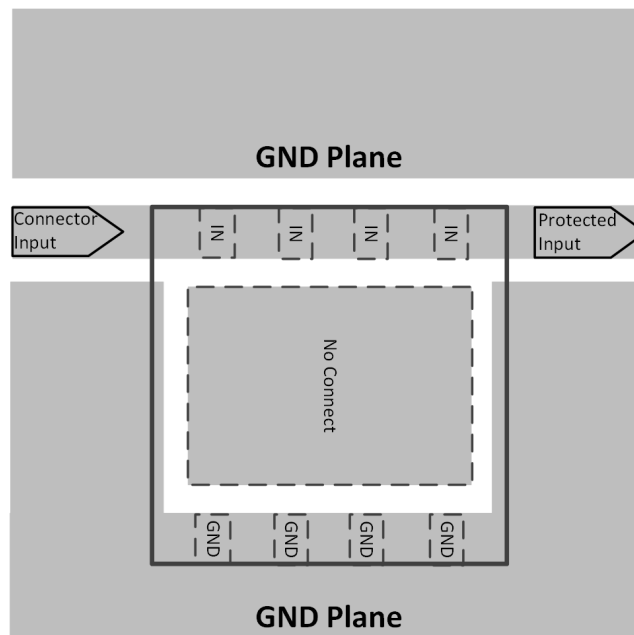

Figure 12-1. TVS3301 Layout

13 Device and Documentation Support

13.1 Documentation Support

13.1.1 Related Documentation

For related documentation, see the following:

- Texas Instruments, [Flat-Clamp Surge Protection Technology for Efficient System Protection white papers](#)
- Texas Instruments, [IEC 61000-4-x Tests for TI's Protection Devices application reports](#)
- Texas Instruments, [Surge Protection Reference Design for PLC Analog Input Module](#)
- Texas Instruments, [TVS Surge Protection in High-Temperature Environments application reports](#)
- Texas Instruments, [TVS3301 Functional Safety, FIT Rate, Failure Mode Distribution and Pin FMA](#)

13.2 Receiving Notification of Documentation Updates

To receive notification of documentation updates, navigate to the device product folder on [ti.com](#). Click on [Subscribe to updates](#) to register and receive a weekly digest of any product information that has changed. For change details, review the revision history included in any revised document.

13.3 Support Resources

[TI E2E™ support forums](#) are an engineer's go-to source for fast, verified answers and design help — straight from the experts. Search existing answers or ask your own question to get the quick design help you need.

Linked content is provided "AS IS" by the respective contributors. They do not constitute TI specifications and do not necessarily reflect TI's views; see TI's [Terms of Use](#).

13.4 Trademarks

TI E2E™ is a trademark of Texas Instruments.

All trademarks are the property of their respective owners.

13.5 Electrostatic Discharge Caution



This integrated circuit can be damaged by ESD. Texas Instruments recommends that all integrated circuits be handled with appropriate precautions. Failure to observe proper handling and installation procedures can cause damage.

ESD damage can range from subtle performance degradation to complete device failure. Precision integrated circuits may be more susceptible to damage because very small parametric changes could cause the device not to meet its published specifications.

13.6 Glossary

[TI Glossary](#) This glossary lists and explains terms, acronyms, and definitions.

14 Mechanical, Packaging, and Orderable Information

The following pages include mechanical, packaging, and orderable information. This information is the most current data available for the designated devices. This data is subject to change without notice and revision of this document. For browser-based versions of this data sheet, refer to the left-hand navigation.

PACKAGING INFORMATION

Orderable Device	Status (1)	Package Type	Package Drawing	Pins	Package Qty	Eco Plan (2)	Lead finish/ Ball material (6)	MSL Peak Temp (3)	Op Temp (°C)	Device Marking (4/5)	Samples
TVS3301DRBR	ACTIVE	SON	DRB	8	3000	RoHS & Green	NIPDAU	Level-2-260C-1 YEAR	-40 to 125	1PQP	Samples

(1) The marketing status values are defined as follows:

ACTIVE: Product device recommended for new designs.

LIFEBUY: TI has announced that the device will be discontinued, and a lifetime-buy period is in effect.

NRND: Not recommended for new designs. Device is in production to support existing customers, but TI does not recommend using this part in a new design.

PREVIEW: Device has been announced but is not in production. Samples may or may not be available.

OBSOLETE: TI has discontinued the production of the device.

(2) **RoHS:** TI defines "RoHS" to mean semiconductor products that are compliant with the current EU RoHS requirements for all 10 RoHS substances, including the requirement that RoHS substance do not exceed 0.1% by weight in homogeneous materials. Where designed to be soldered at high temperatures, "RoHS" products are suitable for use in specified lead-free processes. TI may reference these types of products as "Pb-Free".

RoHS Exempt: TI defines "RoHS Exempt" to mean products that contain lead but are compliant with EU RoHS pursuant to a specific EU RoHS exemption.

Green: TI defines "Green" to mean the content of Chlorine (Cl) and Bromine (Br) based flame retardants meet JS709B low halogen requirements of <=1000ppm threshold. Antimony trioxide based flame retardants must also meet the <=1000ppm threshold requirement.

(3) MSL, Peak Temp. - The Moisture Sensitivity Level rating according to the JEDEC industry standard classifications, and peak solder temperature.

(4) There may be additional marking, which relates to the logo, the lot trace code information, or the environmental category on the device.

(5) Multiple Device Markings will be inside parentheses. Only one Device Marking contained in parentheses and separated by a "-" will appear on a device. If a line is indented then it is a continuation of the previous line and the two combined represent the entire Device Marking for that device.

(6) Lead finish/Ball material - Orderable Devices may have multiple material finish options. Finish options are separated by a vertical ruled line. Lead finish/Ball material values may wrap to two lines if the finish value exceeds the maximum column width.

Important Information and Disclaimer:The information provided on this page represents TI's knowledge and belief as of the date that it is provided. TI bases its knowledge and belief on information provided by third parties, and makes no representation or warranty as to the accuracy of such information. Efforts are underway to better integrate information from third parties. TI has taken and continues to take reasonable steps to provide representative and accurate information but may not have conducted destructive testing or chemical analysis on incoming materials and chemicals. TI and TI suppliers consider certain information to be proprietary, and thus CAS numbers and other limited information may not be available for release.

In no event shall TI's liability arising out of such information exceed the total purchase price of the TI part(s) at issue in this document sold by TI to Customer on an annual basis.

TAPE AND REEL INFORMATION

QUADRANT ASSIGNMENTS FOR PIN 1 ORIENTATION IN TAPE

*All dimensions are nominal

Device	Package Type	Package Drawing	Pins	SPQ	Reel Diameter (mm)	Reel Width W1 (mm)	A0 (mm)	B0 (mm)	K0 (mm)	P1 (mm)	W (mm)	Pin1 Quadrant
TVS3301DRBR	SON	DRB	8	3000	330.0	12.4	3.3	3.3	1.1	8.0	12.0	Q2

TAPE AND REEL BOX DIMENSIONS

*All dimensions are nominal

Device	Package Type	Package Drawing	Pins	SPQ	Length (mm)	Width (mm)	Height (mm)
TVS3301DRBR	SON	DRB	8	3000	338.0	355.0	50.0

DRB 8

GENERIC PACKAGE VIEW

VSON - 1 mm max height

PLASTIC SMALL OUTLINE - NO LEAD

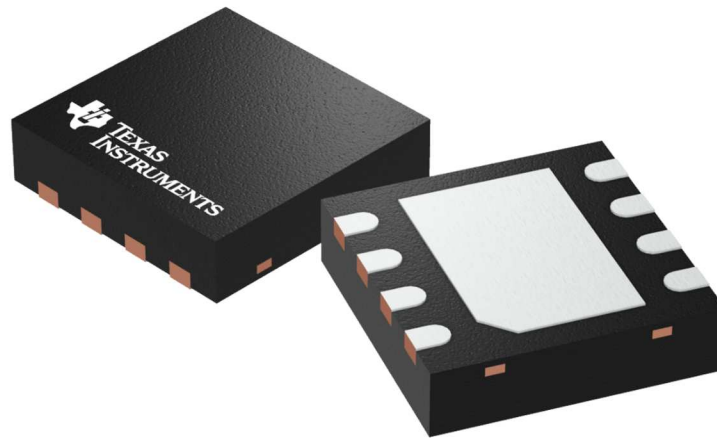

Images above are just a representation of the package family, actual package may vary.
Refer to the product data sheet for package details.

4203482/L

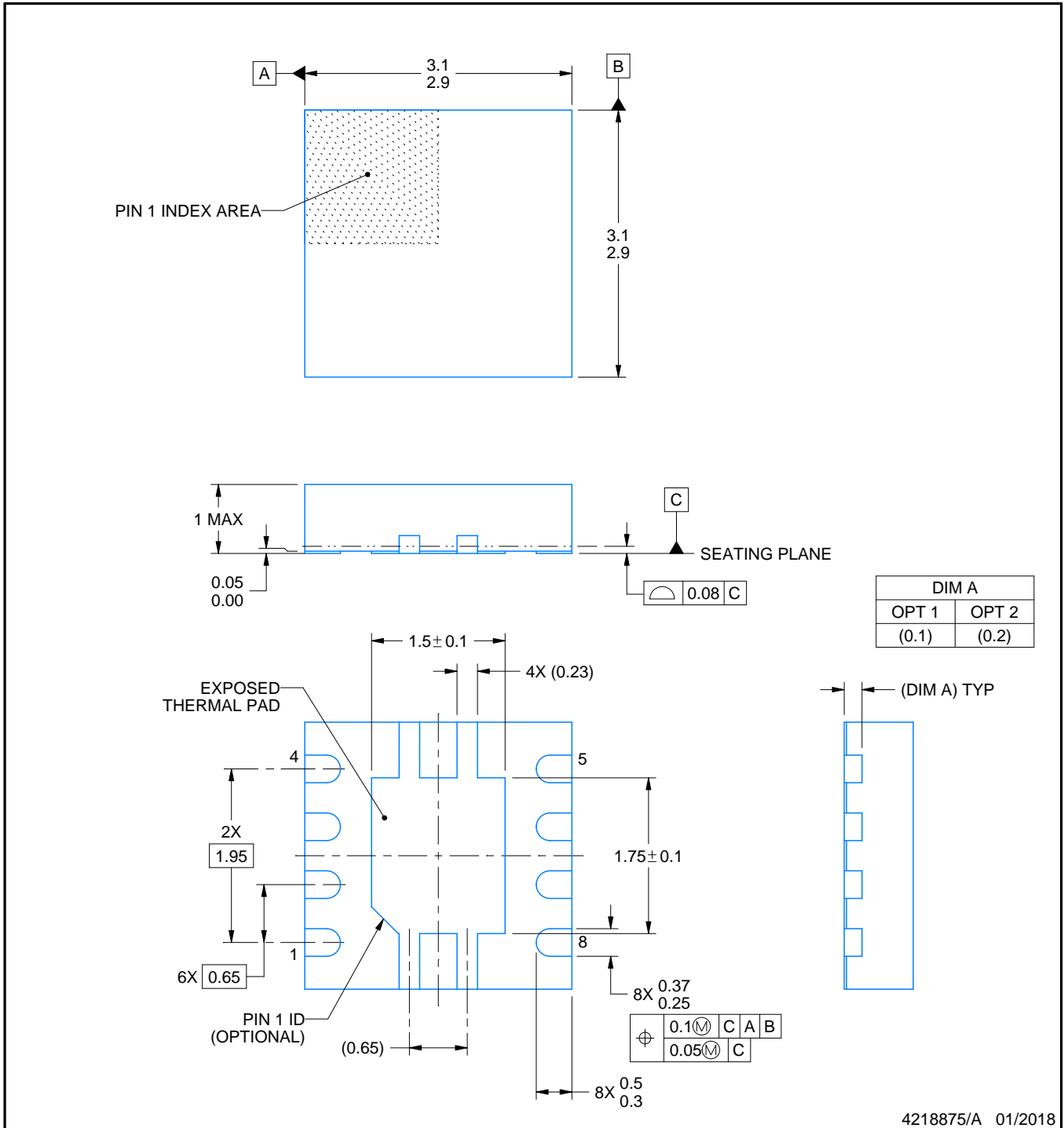

4218875/A 01/2018

NOTES:

1. All linear dimensions are in millimeters. Any dimensions in parenthesis are for reference only. Dimensioning and tolerancing per ASME Y14.5M.
2. This drawing is subject to change without notice.
3. The package thermal pad must be soldered to the printed circuit board for thermal and mechanical performance.

EXAMPLE BOARD LAYOUT

DRB0008A

VSON - 1 mm max height

PLASTIC SMALL OUTLINE - NO LEAD

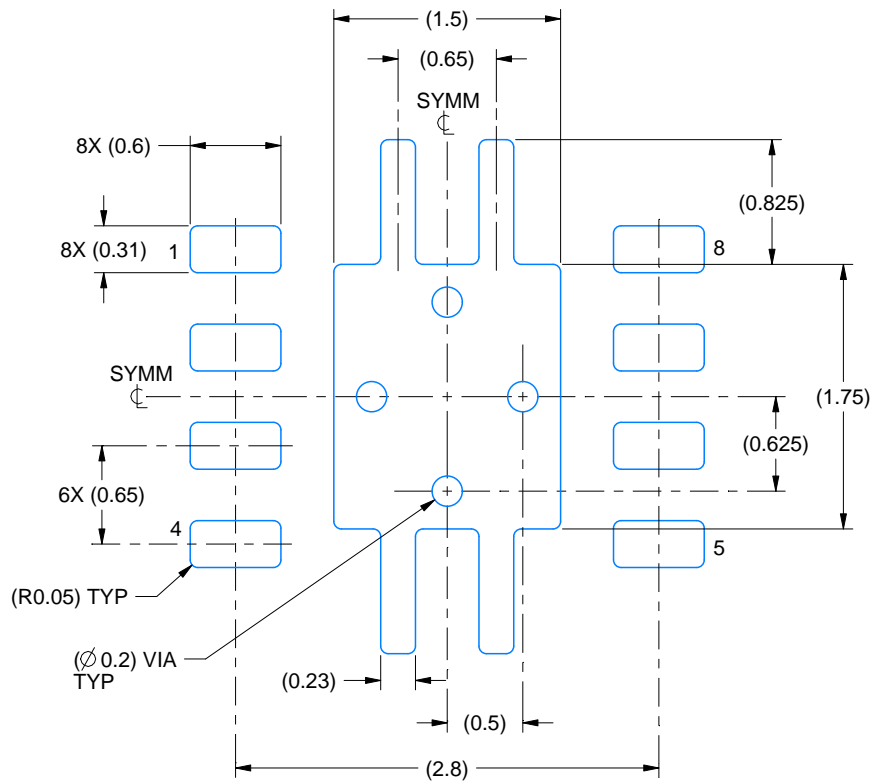

LAND PATTERN EXAMPLE
EXPOSED METAL SHOWN
SCALE:20X

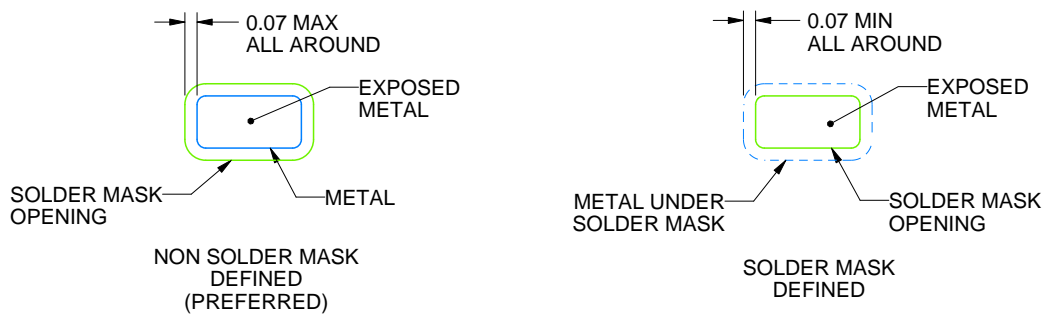

SOLDER MASK DETAILS

4218875/A 01/2018

NOTES: (continued)

4. This package is designed to be soldered to a thermal pad on the board. For more information, see Texas Instruments literature number SLUA271 (www.ti.com/lit/slue271).
5. Vias are optional depending on application, refer to device data sheet. If any vias are implemented, refer to their locations shown on this view. It is recommended that vias under paste be filled, plugged or tented.

EXAMPLE STENCIL DESIGN

DRB0008A

VSON - 1 mm max height

PLASTIC SMALL OUTLINE - NO LEAD

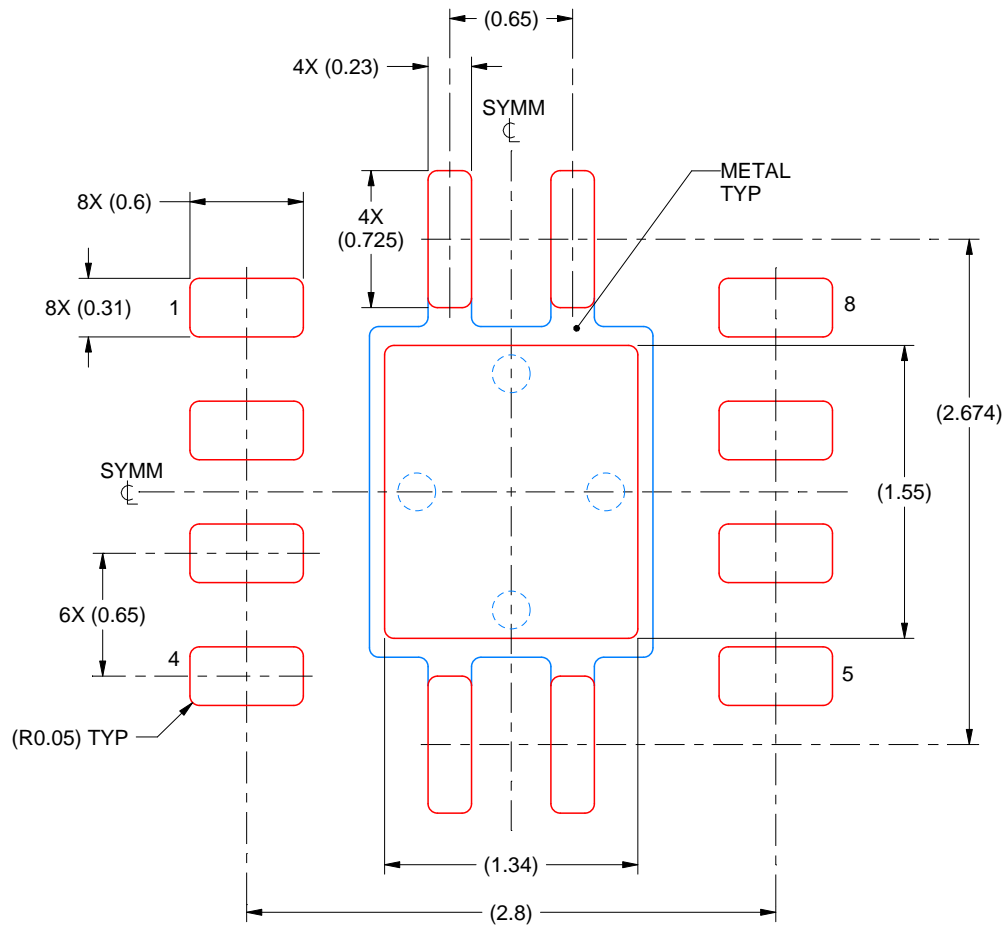

SOLDER PASTE EXAMPLE
BASED ON 0.125 mm THICK STENCIL

EXPOSED PAD
84% PRINTED SOLDER COVERAGE BY AREA
SCALE:25X

4218875/A 01/2018

NOTES: (continued)

6. Laser cutting apertures with trapezoidal walls and rounded corners may offer better paste release. IPC-7525 may have alternate design recommendations.

IMPORTANT NOTICE AND DISCLAIMER

TI PROVIDES TECHNICAL AND RELIABILITY DATA (INCLUDING DATA SHEETS), DESIGN RESOURCES (INCLUDING REFERENCE DESIGNS), APPLICATION OR OTHER DESIGN ADVICE, WEB TOOLS, SAFETY INFORMATION, AND OTHER RESOURCES "AS IS" AND WITH ALL FAULTS, AND DISCLAIMS ALL WARRANTIES, EXPRESS AND IMPLIED, INCLUDING WITHOUT LIMITATION ANY IMPLIED WARRANTIES OF MERCHANTABILITY, FITNESS FOR A PARTICULAR PURPOSE OR NON-INFRINGEMENT OF THIRD PARTY INTELLECTUAL PROPERTY RIGHTS.

These resources are intended for skilled developers designing with TI products. You are solely responsible for (1) selecting the appropriate TI products for your application, (2) designing, validating and testing your application, and (3) ensuring your application meets applicable standards, and any other safety, security, regulatory or other requirements.

These resources are subject to change without notice. TI grants you permission to use these resources only for development of an application that uses the TI products described in the resource. Other reproduction and display of these resources is prohibited. No license is granted to any other TI intellectual property right or to any third party intellectual property right. TI disclaims responsibility for, and you will fully indemnify TI and its representatives against, any claims, damages, costs, losses, and liabilities arising out of your use of these resources.

TI's products are provided subject to [TI's Terms of Sale](#) or other applicable terms available either on [ti.com](https://www.ti.com) or provided in conjunction with such TI products. TI's provision of these resources does not expand or otherwise alter TI's applicable warranties or warranty disclaimers for TI products.

TI objects to and rejects any additional or different terms you may have proposed.

Mailing Address: Texas Instruments, Post Office Box 655303, Dallas, Texas 75265
Copyright © 2023, Texas Instruments Incorporated

Looking for pricing, stock, or lifecycle information?

Click below to explore more details on WIN SOURCE:

 [View TVS3301DRBR on WIN SOURCE](#)

 [Texas Instruments](#) Information

Optimize Your Supply Chain with WIN SOURCE Solutions

-  Global Sourcing Solution
-  Obsolete Management
-  Cost Control Management
-  Shortage Management
-  Alternative Solution
-  Excess Inventory Management