

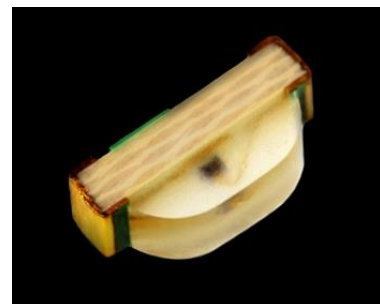

**THE DATASHEET OF
YPY1113F-1215-TR**





Features

Package	Smaller, thinner, side view package, Milky white resin
Product features	<ul style="list-style-type: none">• Outer dimension 2.1 x 1.0 x 0.6mm (L x W x H)• Lead-free soldering compatible• RoHS2 compliant

Recommended Applications

- Amusement machine, Home appliances, OA/FA use, Various indicators, etc.

Outline Dimensions

YPY113F-1215-TR

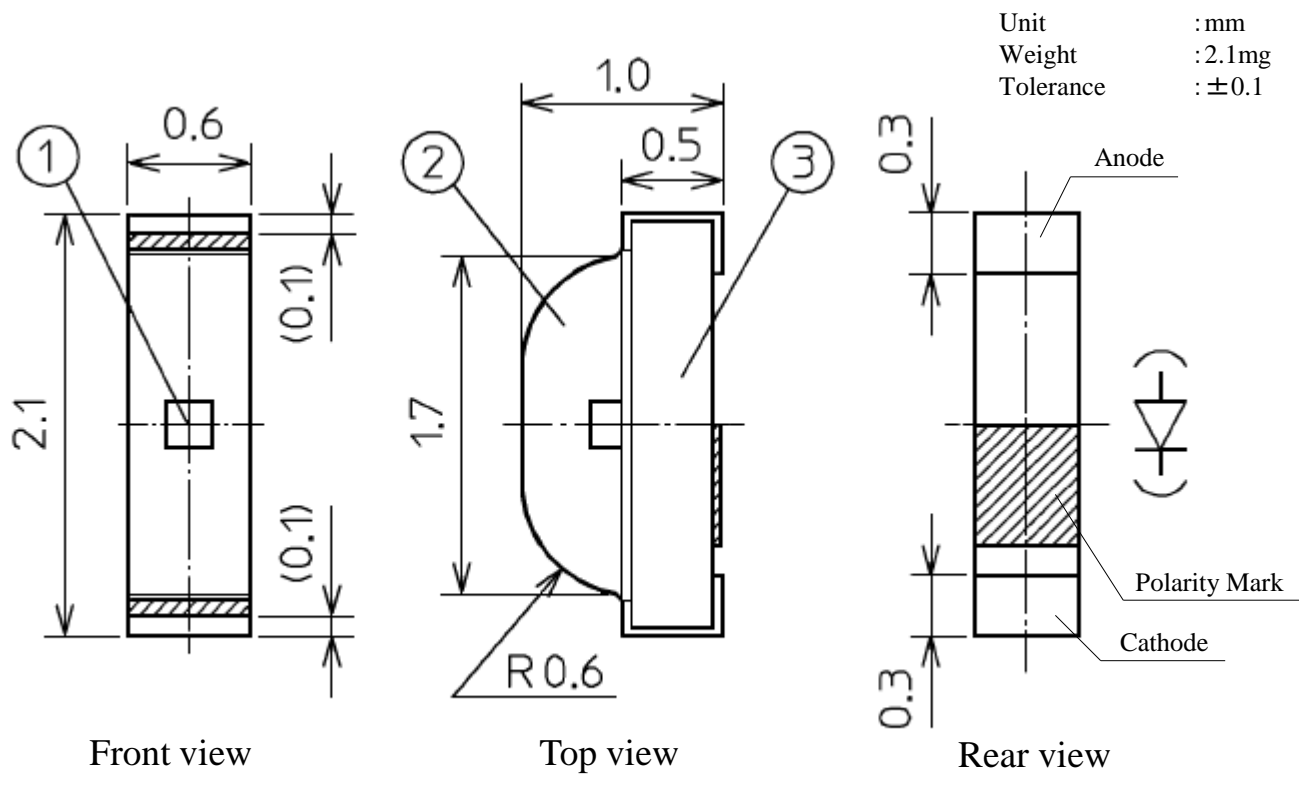

No.	PART NAME	MATERIAL	QTY.
①	LED Die	AlGaInP	1
②	Mold Resin	Epoxy Resin	1
③	Substrate	Glass Fabrics	1

Recommended Pad

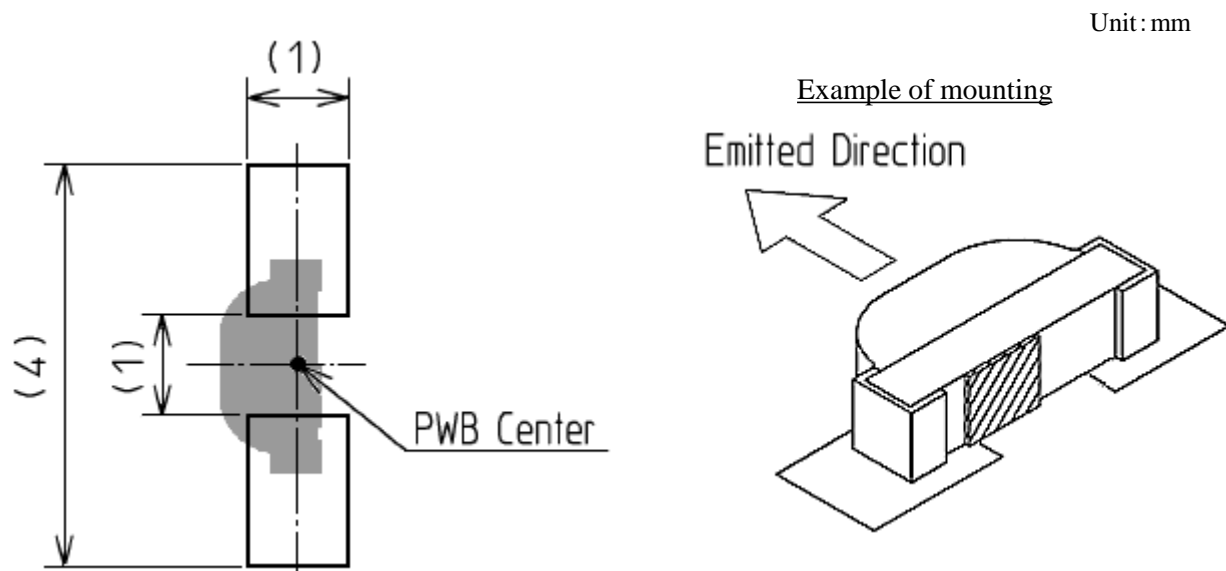

Specifications

YPY1113F-1215-TR

【 Product Overview 】

Die Material	AlGaInP
Emitting Color	Yellow Green
Resin Color	Milky white

【 Absolute Maximum Ratings 】

(Ta=25°C)

ITEM	SYMBOL	MAXIMUM RATINGS	UNITS
Power Dissipation	Pd	36	mW
Forward Current	IF	15	mA
Repetitive Peak Forward Current "Pulse width ≤ 1ms, Duty ≤ 1/20duty"	IFRM	48	mA
IF Derate Linearly from "25°C"	ΔIF	0.21	mA/°C
IFRM Derate Linearly from "25°C" "Pulse width ≤ 1ms, Duty ≤ 1/20duty"	ΔIFRM	0.69	mA/ °C
Reverse Voltage	VR	5	V
Operating Temperature	Topr	-40 ~ +85	°C
Storage Temperature	Tstg	-40 ~ +100	°C
Soldering Temperature "Reflow Soldering"	Tsld	260	°C

Note1

Note1 Please refer to page 8, Soldering conditions.

【 Electro and Optical Characteristics 】

(Ta=25°C)

ITEM	SYMBOL	CONDITIONS	MIN.	TYP.	MAX.	UNITS
Forward Voltage	VF	IF = 5mA	-	1.9	2.4	V
Reverse Current	IR	VR = 5V	-	-	100	μA
Luminous Intensity	Iv	IF = 5mA	6.3	10.0	25.0	mcd
Peak Wavelength	λp	IF = 5mA	-	575	-	nm
Dominant Wavelength	λd	IF = 5mA	566	572	578	nm
Spectral Line Half Width	Δλ	IF = 5mA	-	15	-	nm

Above the table of Luminous Intensity (Iv) and Dominant Wavelength (λd) are range of actual measuring value of the production line of STANLEY ELECTRIC.

【Tolerance : Iv... ±10%, λd... ±1nm】

Specifications

YPY1113F-1215-TR

【 Sorting For Luminous Intensity and Dominant Wavelength 】

LED's shall be sorted out into the following ranks of Luminous Intensity and Dominant Wavelength.

Luminous Intensity (I_v) Rank

Rank	I_v (mcd)		Conditions
	MIN.	MAX.	
B	6.3	10.0	$I_F=5mA$ $T_a=25^{\circ}C$
C	10.0	16.0	
D	16.0	25.0	

Dominant Wavelength (λ_d) Rank

Rank	λ_d (nm)		Conditions
	MIN.	MAX.	
A	566	569	$I_F=5mA$ $T_a=25^{\circ}C$
B	569	572	
C	572	575	
D	575	578	

Notes Above the table of Luminous Intensity (I_v) and Dominant Wavelength (λ_d) are range of actual measuring value of the production line of STANLEY ELECTRIC.
【Tolerance : $I_v \dots \pm 10\%$, $\lambda_d \dots \pm 1nm$ 】

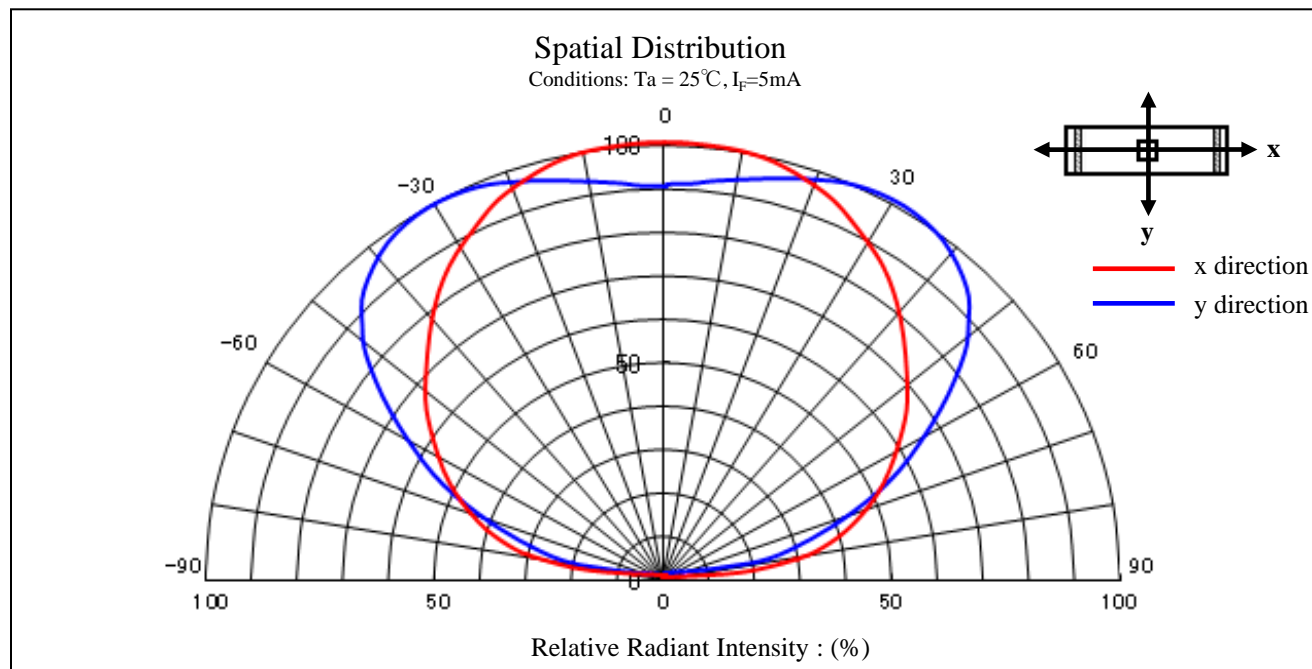
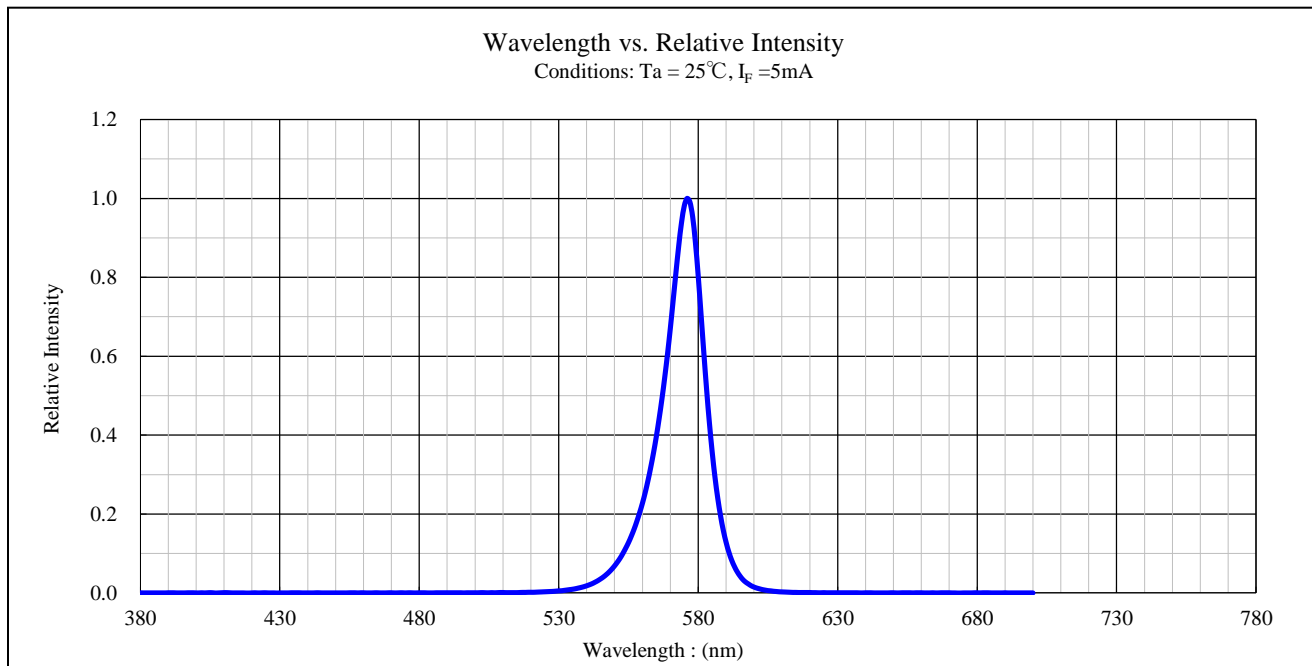

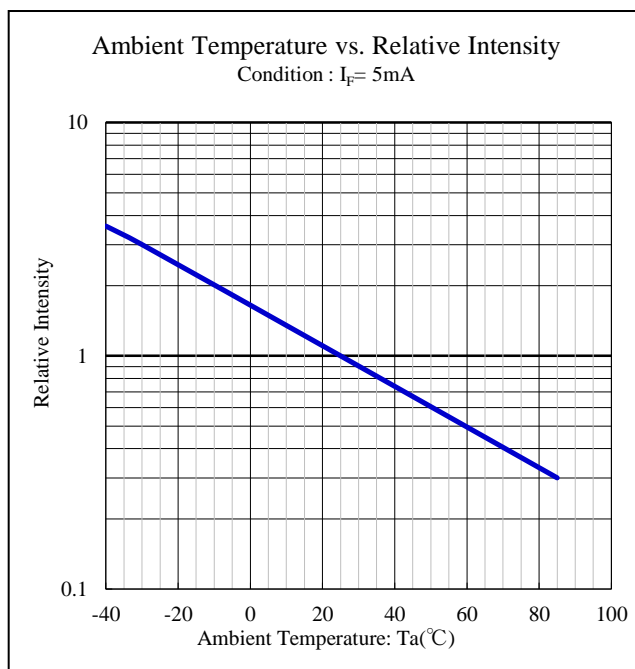
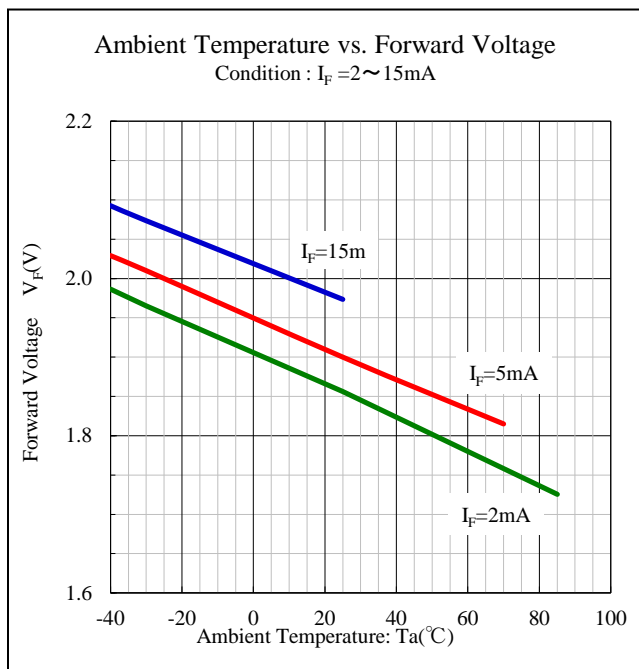
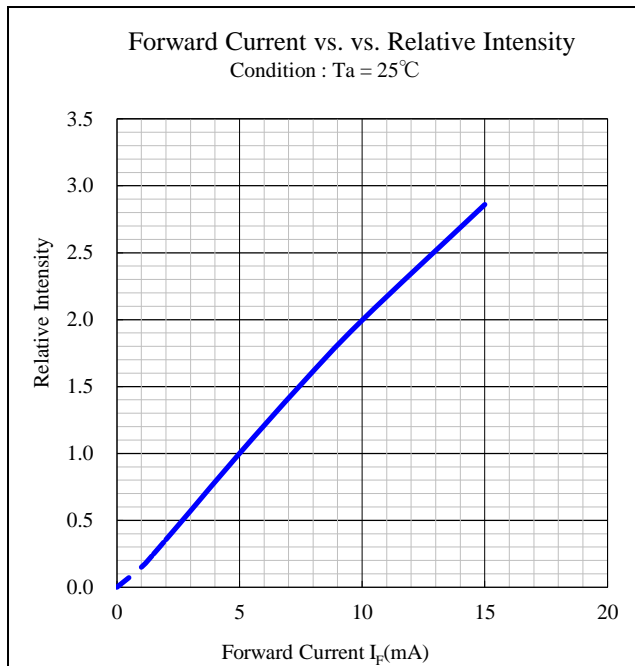
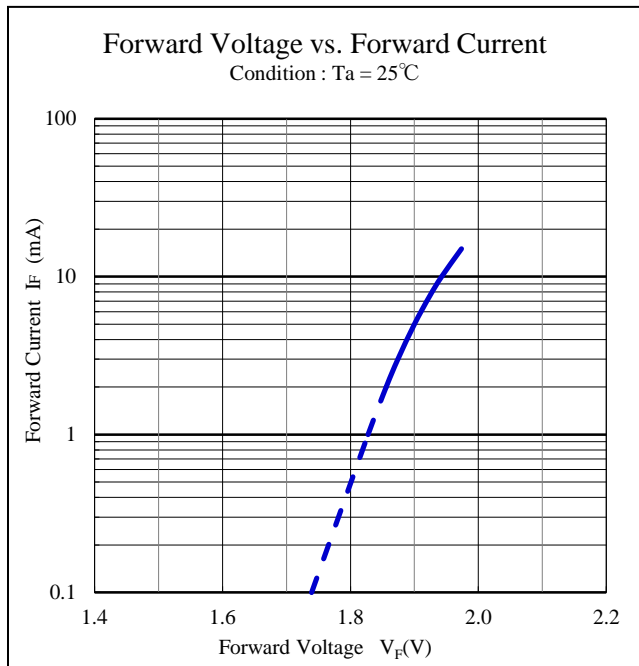

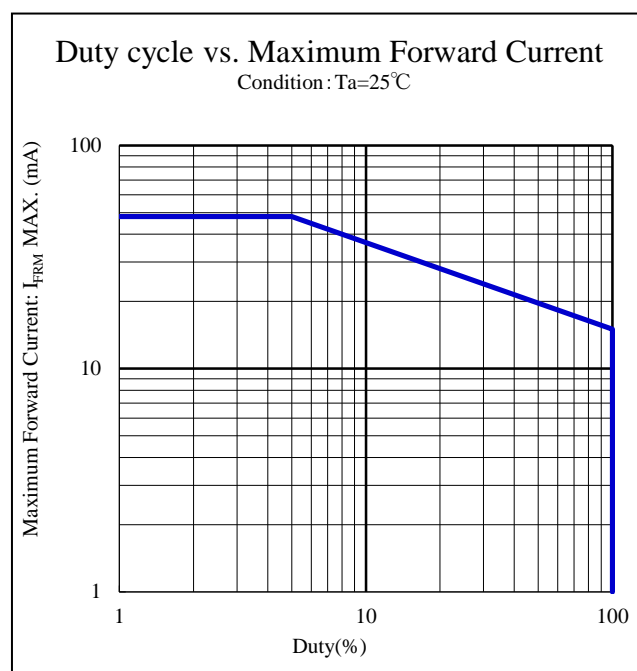
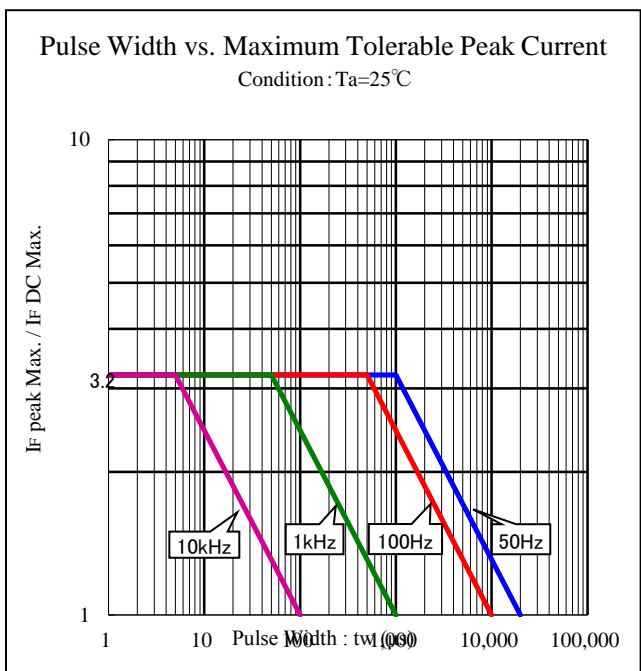
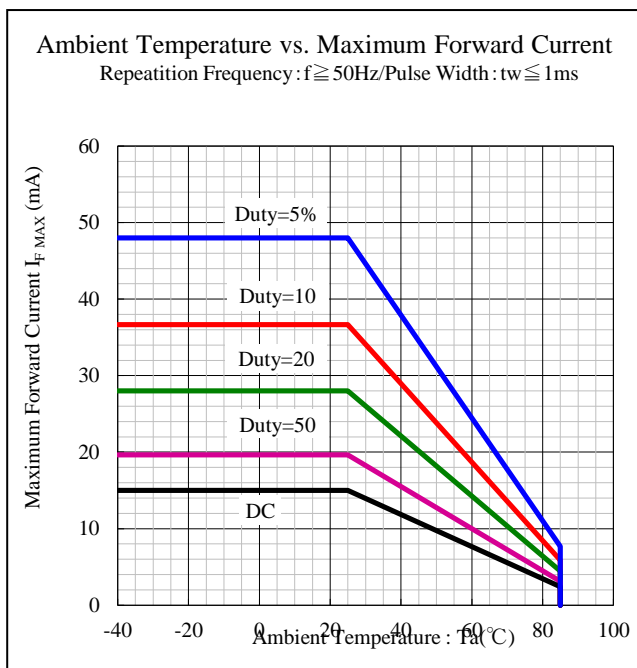
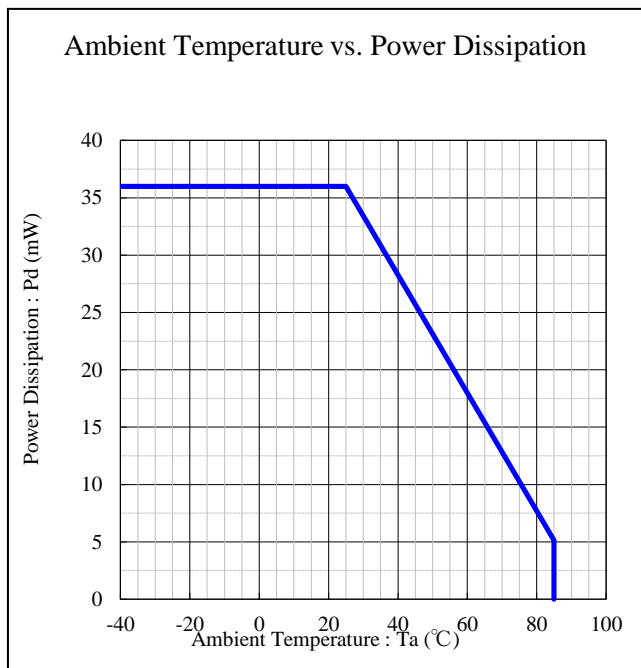

Soldering conditions

YPY1113F-1215-TR

1. Reflow Soldering

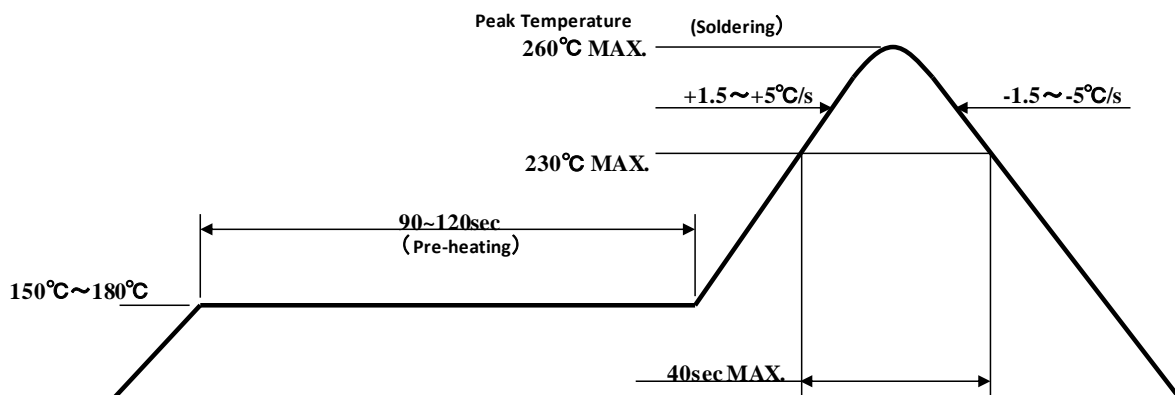
【Recommended Reflow Soldering Condition.】

1. The above temp. profile shall be at the surface of LED resin.
2. The number of reflow process shall be 2 time MAX. If second reflow process would be performed, intervals between first and second process shall be as short as possible to prevent absorption of moisture to resin of LED. Cooling process to normal temp. shall be required between first and second reflow process.
3. Temp. fluctuation to LED at pre-heat process shall be minimized.

2. Manual Soldering (Soldering iron)

Temperature of Iron Tip	350°C MAX.
Soldering Duration, Time	3sec. MAX., 1 time

※ The number of manual soldering process shall be 1 time.

3. Other Caution

1. As manual soldering, please heat the solder pad, should not contact a tip of iron to a product (especially resin).
2. Heat or UV(or both) curing resin shall used for preliminary fixing.
Curing condition temp. : 150 °C MAX. , time : 120s MAX.
3. After soldering, any mechanical force or any excess vibration shall not be accepted to apply during cooling process to normal temp.

1. Cleaning

- Special care shall be taken when applying the chemicals listed below for cleaning because certain chemicals may damage the surface of lens or care and cause discoloration.

Cleaning agents	Recommended/ Not recommended
Isopropyl alcohol	✓ Recommended
Ethyl alcohol	✓ Recommended
Pure water	✓ Recommended
Trichloroethylene	x Not recommended
Chlorothene	x Not recommended
Acetone	x Not recommended
Thinner	x Not recommended

- ※ Dipping time is 3minutes MAX. (In normal temp.)
- ※ It can be cleaned on the next page conditions, about pure water.

- Effect of ultrasonic cleaning on the LED resin body differs depending on such factors as the oscillator output, size of P.C.B. and LED mounting method. So the use of ultrasonic cleaning is strongly recommended after confirming that there is no problem.
- When using Freon equivalent solvent, discoloration on the LED surface may be caused by one of the first confirming that there is no problem.
 - ※ Freon substitute detergent
 - Clean through 750H
 - Pine alpha ST-100S
- In the case of water-washing , ensure to use pure water (not city water) and , immediately after the washing is over, apply forced drying to remove all the moisture from the LED.

2. Warrant period

Within 6 month by following conditions.

Un-opened, +5~+30°C/ 70% MAX.

3. Handling after opened

- In case of no-using promptly or on the way to using, LEDs should be restored following conditions and the bag should be fastened the zip lock to prevent absorption of moisture to resin of LEDs.
+5~+30°C/ 70% MAX.
- Unpacked LEDs should be stored under the following conditions.
LEDs must be soldered on board **within 72h** whether they are restored in the bag or not.
+5~+30°C/ 70% MAX.
- In any case over 72h has past after opening the bag or the indicator color of the desiccant has changed(Blue→Pink), baking should be performed under the following conditions.
+60±5°C, 10~12 hours

【 Other Precautions 】

1. Stanley LED Lamps have semiconductor characteristics and are designed to ensure high reliability. However, the performance may vary depending on usage conditions
2. Absolute Maximum Ratings are set to prevent LED lamps from failing due to excess stress(temperature, current, voltage, etc.). Usage conditions must not exceed the ratings for a moment, nor do reach one item of absolute maximum ratings simultaneously.
3. In order to ensure high reliability from LED Lamps, variable factors that arise in actual usage conditions should be taken into account for designing. (Derating of TYP., MAX Forward Voltage, etc.)
4. Please insert protective resistors into the circuit in order to stabilize LED operation and to prevent the device from igniting due to excess current.
5. Please check the actual performance in the assembly because the Specification Sheets are described for LED device only.
6. Please refrain from looking directly at the light source of LED at high output, as it may harm your vision.
7. The products are designed to operate without failure in recommended usage conditions. However, please take the necessary precautions to prevent fire, injury, and other damages should any malfunction or failure arise.
8. The products are manufactured to be used for ordinary electronic equipment. Please contact our sales staff beforehand when exceptional quality and reliability are required, and the failure or malfunction of the products might directly jeopardize life or health (such as for airplanes, aerospace, transport equipment, medical applications, nuclear reactor control systems and so on).
9. When there is a process of supersonic wave welding etc. after mounting the product, there is a possibility of affecting on the reliability of junction part in package (junction part of die bonding and wire bonding). Please make sure there is no problem before using.
10. The formal specification sheets shall be valid only by exchange of documents signed by both parties.

【Moisture-proof Packaging Specification】

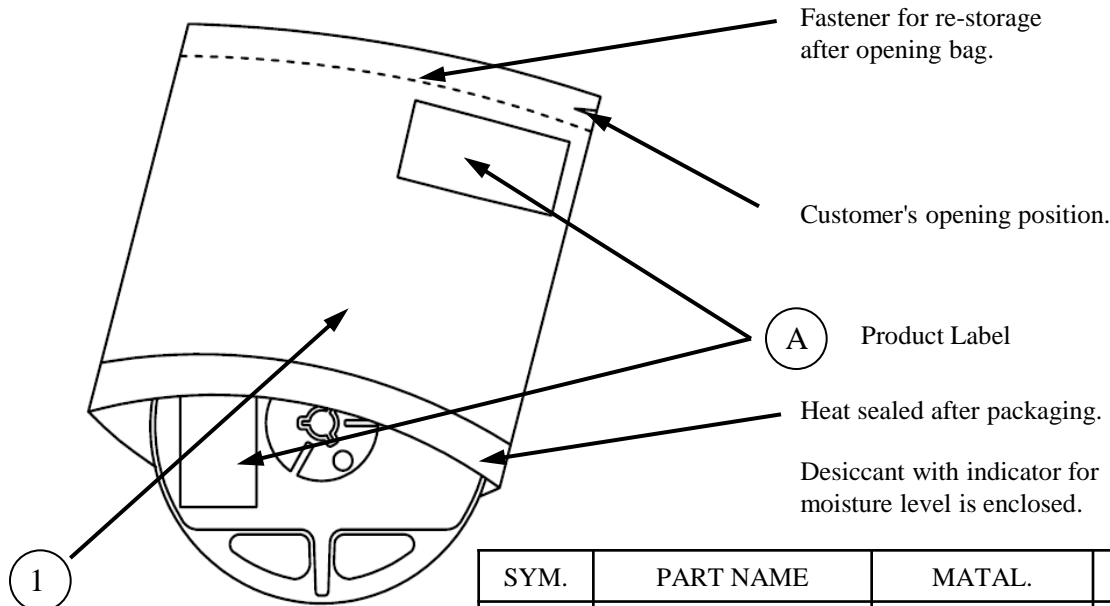

SYM.	PART NAME	MATAL.	REMARKS
①	Moisture-proof bag with Aluminum layer	PET+Al+PE	with ESD protection

2. Packaging Box Specifications

Flow Chart-package Opening to Mounting

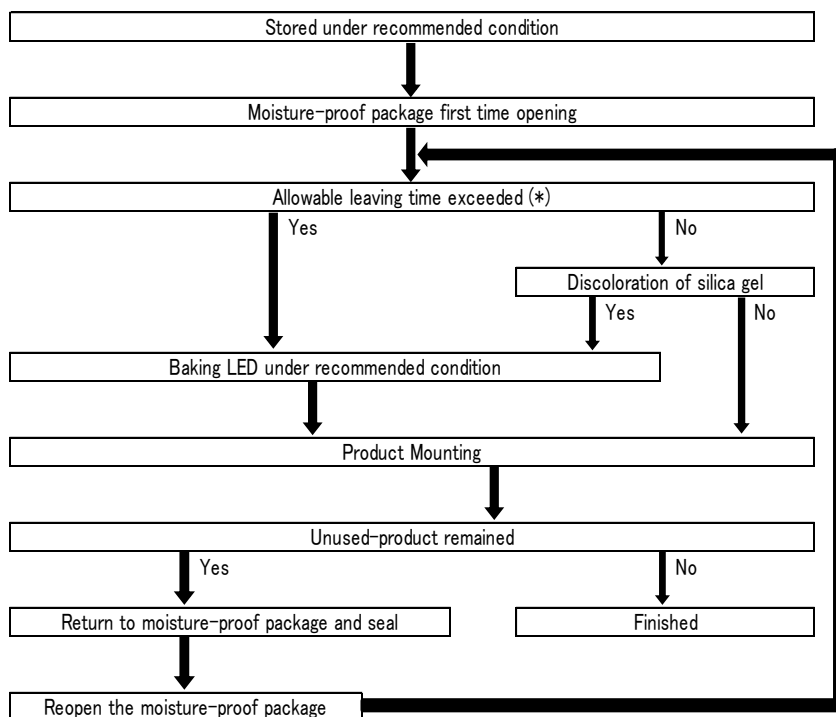

Allowable leaving time means the maximum allowable leaving time after opening package, which depends on each LED type. The allowable leaving time should be calculated from the first opening of package to the time when soldering process is finished. When judging if the allowable leaving time has exceeded or not, please subtract the soldering time. The allowable leaving time after reopening should be calculated from the first opening of package, or from the time when baking process is finished.

Packaging Specifications

YPY113F-1215-TR

【 Packing box 】

(RoHS2•ELV Compliant)

Box TYPE	Outline dimension L × W × H (mm)	Capacity of the box
Type A	280 × 265 × 45 (mm)	3 reels
Type B	310 × 235 × 265 (mm)	15 reels
Type C	440 × 310 × 265 (mm)	30 reels

The above measure is all the reference value.

The box is selected out of the above table, by the shipping quantity.

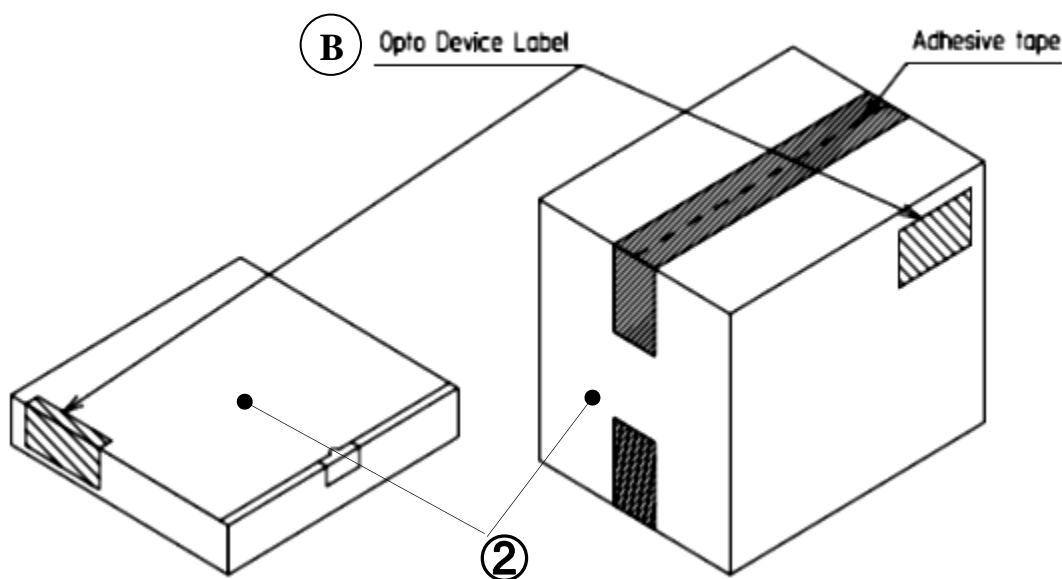

Type A

Material / box : Cardboard C5BF

Type B,C

Material / box : Cardboard K5AF

Partition : Cardboard K5AF

No.	PART NAME	MATERIAL	REMARKS
②	Packing Box	Corrugated Cardboard	without ESD protection

Packaging Specifications

YPY1113F-1215-TR

【 Label Specification】

(acc.to ; JIS-X0503(Code-39)

A Product label

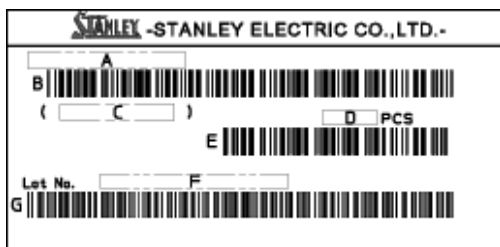

- A. Parts number (Indicated the whole parts number)
- B. Bar-code for parts number
- C. Parts code (In-house identification code for each parts number)
- D. Packed parts quantity (Indicated Parts Qty in the packing)
- E. Bar-Code for packed parts quantity
- F. Lot number & Rank (indicated the following 16 digits)
- G. Bar-Code for Lot number & Rank

B Opto device label

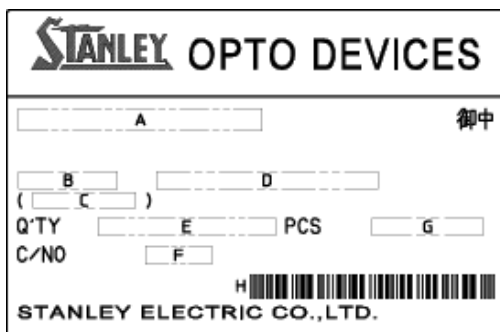

- A. Custmer Name
- B. Parts Type
- C. Parts Code
- D. Parts Number
- E. Packed Parts Quantity
- F. Carton Number
- G. Shipping Date
- H. Bar-Code for In-house identification Number

<Remark> Bar-code font : acc.to Code-39(JIS-X0503)

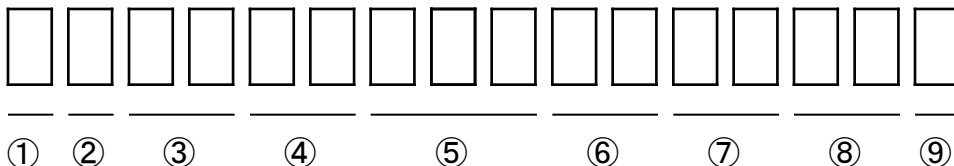

① - 1digit : Production Location (Mark identify alphabet)

② - 1digit : Production Year (Last Digit of Production Year shall be indicate as 2020→0, 2021→1, 2022→2,····)

③ - 2digits : Production Month (Jan. to Sep. ,shall be indicated as 01,02,03,····)

④ - 2digits : Production Date

⑤ - 3digits : Serial Number

⑥ - 2digits : Tape and Reel following Number

⑦ - 2digits : Luminous Intensity Rank.

(If luminous intensity rank is 1 digit, "-" shall be dashed on the place for the second digit.

If there is no identified rank, "- -" shall be used to indicate.)

⑧ - 2digits : Color Rank

(If chromaticity rank is 1 digit, "-" shall be dashed on the place for the second digit.

If there is no identified rank, "- -" shall be used to indicate.)

⑨ - 1digit : Option Rank (Stanley normally print "-" to indicate.)

Taping and Reel Specifications

YPY113F-1215-TR

(acc.to ; JIS-C0806-03)

1. Appearance

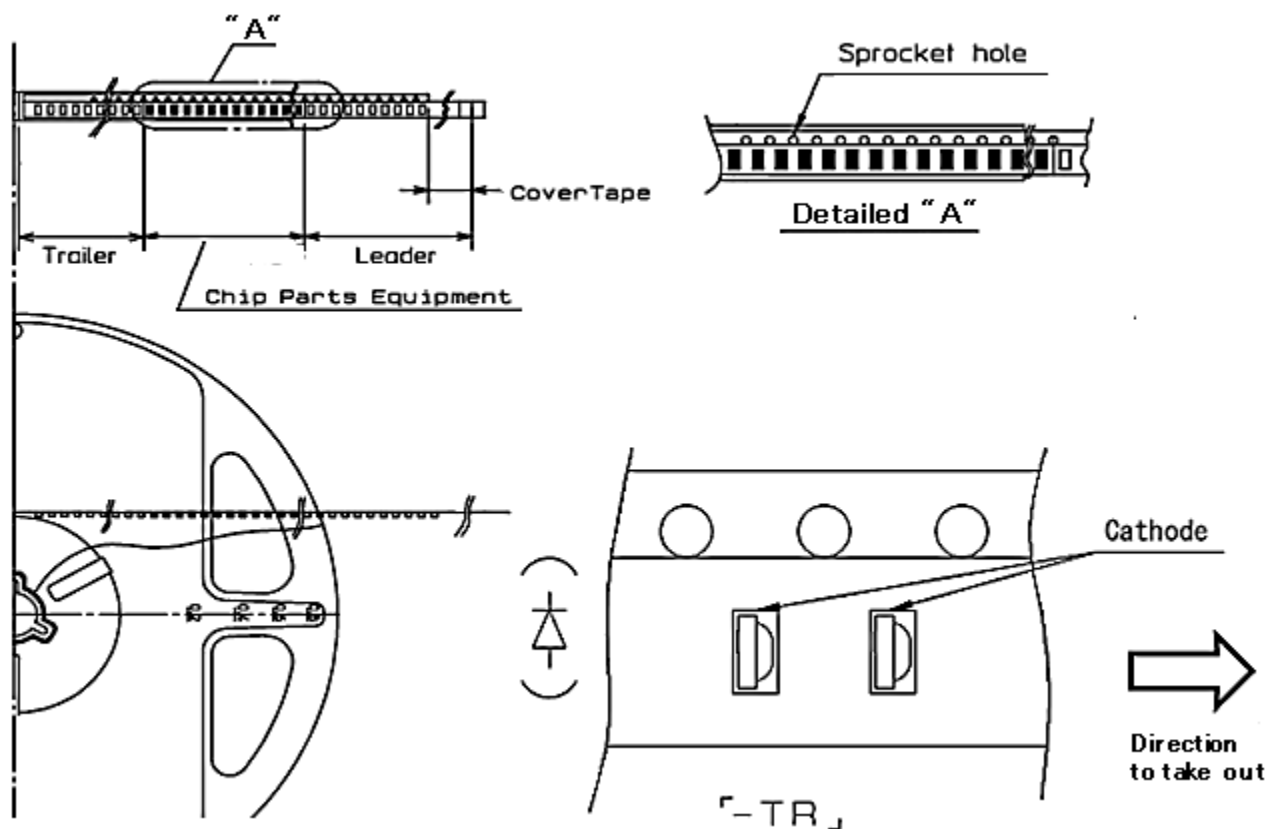

Note

"-TR" means Cathode Side of LEDs should be placed on the sprocket-hole side.

Items		Specifications	Remarks
Leader area	Cover-tape	Cover-tape shall be longer than 200mm without carrier-tape	The end of cover-tape shall be held with adhesive tape.
	Carrier-tape	Empty pocket shall be more than 10 pieces.	Please refer to the above figure for Taping & reel orientation.
Trailer area		Empty pocket shall be more than 15 pieces.	The end of taping shall be inserted into a slit of the hub.



Taping and Reel Specifications

YPY1113F-1215-TR

2. Qty. per Reel

4,000 pcs./reel

3. Mechanical strength

Cover-tape adhesive strength shall be 0.1~1.0N (An angle between carrier-tape and cover-tape shall be 170 deg.) Both tapes shall be so sealed that the contained parts will not come out from the tape when it is bent at a radius of 15mm.

4. Others

Reversed-orientation, Up-side down placing, side placing and out of spec. parts mix shall not be held.

No more than 1 connecting empty pockets of taping.

Empty Pocket per reel is assumed until 5piece.

Taping and Reel Specifications

YPY113F-1215-TR

Unit : mm

(acc.to ; JIS-C0806)

5. Taping Dimensions

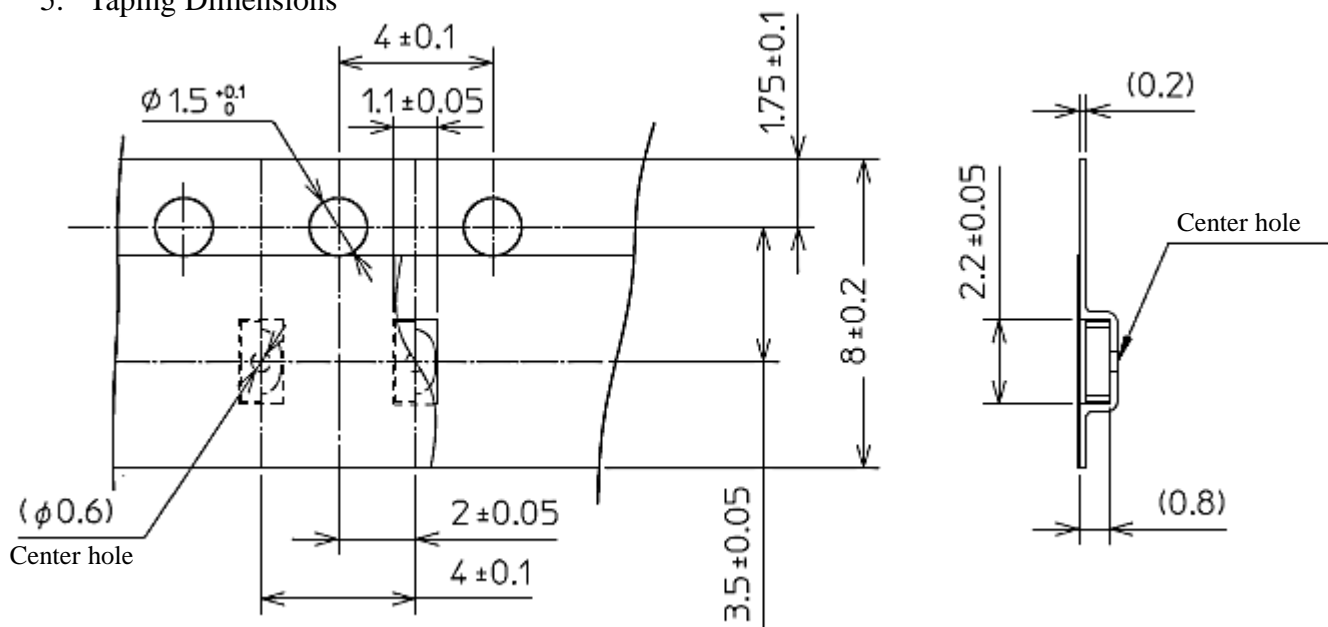

6. Reel Dimension

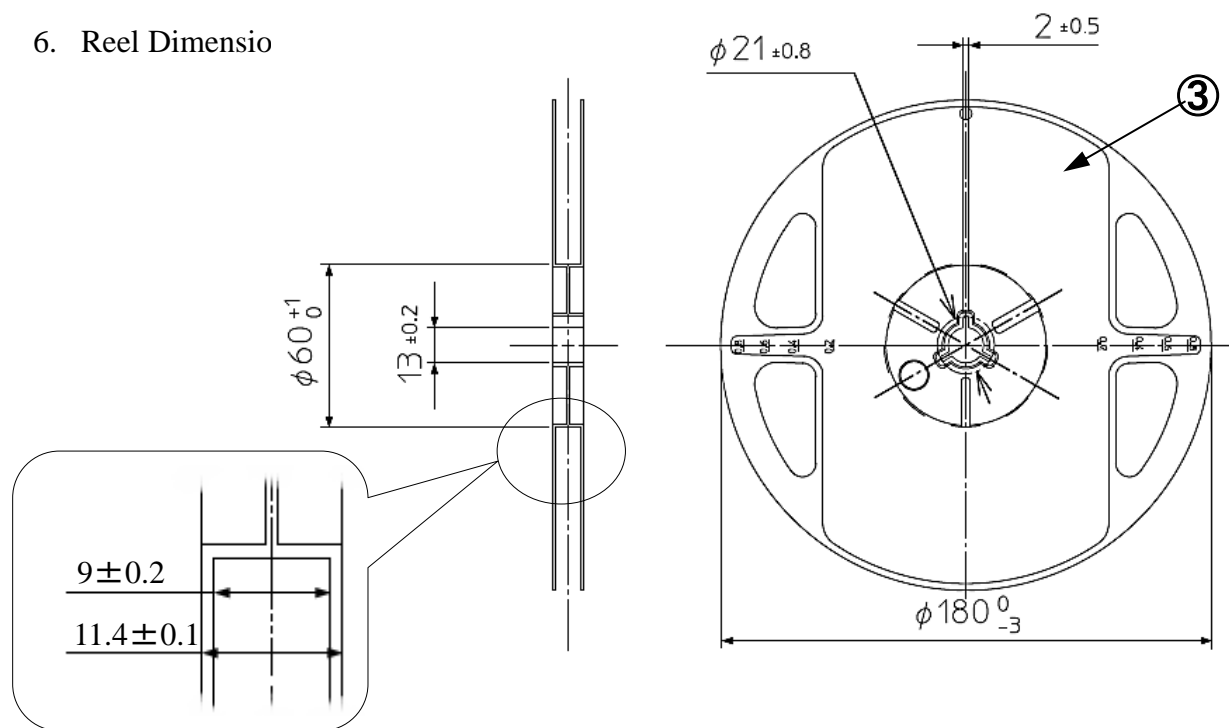

NO.	PART NAME	REMARKS
①	Carrier-tape	Conductive Grade
②	Cover-tape	Anti-Static Grade
③	Carrier-reel	Conductive Grade

This product is in compliance with RoHS2/ ELV.

Prohibition substance and it's criteria value of RoHS2/ ELV are as follows.

- RoHS2 instruction ... Refer to following 1 to 10.
- ELV instruction ... Refer to following 1 to 4.

No.	Substances	Threshold
1	Lead and its compounds	0.1% (1,000ppm)
2	Mercury and its compounds	0.1% (1,000ppm)
3	Cadmium and its compounds	0.01% (100ppm)
4	Hexavalent chromium compounds	0.1% (1,000ppm)
5	PBB : Polybrominated Biphenyls	0.1% (1,000ppm)
6	PBDE : Polybrominated Biphenyl Ethers	0.1% (1,000ppm)
7	DEHP : Bis (2-ethylhexyl) phthalate	0.1% (1,000ppm)
8	BBP : Butyl benzyl phthalate	0.1% (1,000ppm)
9	DBP : Dibutyl phthalate	0.1% (1,000ppm)
10	DIBP : Diisobutyl phthalate	0.1% (1,000ppm)

Reliability Testing Result

YPY1113F-1215-TR

Reliability Testing items	Applicable Standard	Testing Conditions	Duration	Failure
Room Temp. Operating Life	EIAJ ED-4701/100(101)	Ta = 25°C, I _F = 15mA	1,000 h	0/25
Resistance to Soldering Heat	EIAJ ED-4701/300(301)	Pre-heating : 150~180°C 120s Max. Operation Heating : 230°C 40s Max. Peak Temperature : 260°C	2 times	0/25
Temperature Cycling	EIAJ ED-4701/100(105)	-40°C (30min) ~ Normal Temperature(15min) ~ +100°C (30min) ~ Normal Temperature(15min)	5 cycles	0/25
Wet High Temp. Storage Life	EIAJ ED-4701/100(103)	Ta = 60±2°C, RH = 90±5%	1,000 h	0/25
High Temp. Storage Life	EIAJ ED-4701/200(201)	Ta = +100°C±2°C	1,000 h	0/25
Low Temp. Storage Life	EIAJ ED-4701/200(202)	Ta = -40°C±2°C	1,000 h	0/25
Vibration, Variable Frequency	EIAJ ED-4701/400(403)	98.1m/s ² (10G), 100 ~ 2KHz sweep for 20min., XYZ each direction	2 h	0/10

Failure Criteria



Items	Symbols	Conditions	Failure criteria
Luminous Intensity	I _v	5mA	Testing Min. Value < Spec. Min. Value x 0.5
Forward Voltage	V _F	5mA	Testing Max. Value ≥ Spec. Max. Value x 1.2
Reverse Current	I _R	5V	Testing Max. Value ≥ Spec. Max. Value x 2.5
Cosmetic Appearance	-	-	Occurrence of notable decoloration, deformation and cracking

Special Notice to Customers Using the Products and Technical Information Shown in This Data Sheet







- 1) The technical information shown in the data sheets are limited to the typical characteristics and circuit examples of the referenced products. It does not constitute the warranting of industrial property nor the granting of any license.
- 2) For the purpose of product improvement, the specifications, characteristics and technical data described in the data sheets are subject to change without prior notice. Therefore it is recommended that the most updated specifications be used in your design.
- 3) When using the products described in the data sheets, please adhere to the maximum ratings for operating voltage, heat dissipation characteristics, and other precautions for use. We are not responsible for any damage which may occur if these specifications are exceeded.
- 4) The products that have been described to this catalog are manufactured so that they will be used for the electrical instrument of the benchmark (OA equipment, telecommunications equipment, AV machine, home appliance and measuring instrument).
The application of aircrafts, space borne application, transportation equipment, medical equipment and nuclear power control equipment, etc. needs a high reliability and safety, and the breakdown and the wrong operation might influence the life or the human body. Please consult us beforehand if you plan to use our product for the usages of aircrafts, space borne application, transportation equipment, medical equipment and nuclear power control equipment, etc. except OA equipment, telecommunications equipment, AV machine, home appliance and measuring instrument.
- 5) In order to export the products or technologies described in this data sheet which are under the "Foreign Exchange and Foreign Trade Control Law," it is necessary to first obtain an export permit from the Japanese government.
- 6) No part of this data sheet may be reprinted or reproduced without prior written permission from Stanley Electric Co., Ltd.
- 7) The most updated edition of this data sheet can be obtained from the address below:
<http://www.stanley-components.com/en/>

Looking for pricing, stock, or lifecycle information?

Click below to explore more details on WIN SOURCE:

-  [View YPY1113F-1215-TR on WIN SOURCE](#)
-  [Stanley Electric Co Information](#)

Optimize Your Supply Chain with WIN SOURCE Solutions

-  Global Sourcing Solution
-  Obsolete Management
-  Cost Control Management
-  Shortage Management
-  Alternative Solution
-  Excess Inventory Management