



**THE DATASHEET OF
MLX90367LDC-ABV-000-RE**



MLX90367 Triaxis® Position Sensor IC

Datasheet

Features and Benefits

- Triaxis® Hall Technology **Triaxis®**
- On Chip Signal Processing for Robust Absolute Position Sensing
- Simple Magnetic Design
- Programmable Measurement Range
- Programmable Linear Transfer Characteristic (Multi-points)
- SENT output (according to SAE J2716-2010)
- 12 bit Resolution - 10 bit Thermal Accuracy
- 48 bit ID Number option
- Single Die – SOIC-8 Package RoHS Compliant
- Dual Die (Full Redundant) – TSSOP-16 Package RoHS Compliant
- Output Thermal Offset correction



Applications

- Absolute Rotary Position Sensor
- Absolute Linear Position Sensor
- Pedal Position Sensor
- Steering Wheel Position Sensor
- Throttle Position Sensor
- Float-Level Sensor
- Ride Height Position Sensor
- Non-Contacting Potentiometer

Description

The MLX90367 is a monolithic sensor IC sensitive to the flux density applied orthogonally and parallel to the IC surface.

The MLX90367 is sensitive to the three components of the flux density applied to the IC (i.e. B_x , B_y and B_z). This allows the MLX90367 with the correct magnetic circuit to decode the absolute position of any moving magnet (e.g. rotary position from 0 to 360 Degrees or linear displacement, stroke). It enables the design of novel generation of non-contacting position sensors that are frequently required for both automotive and industrial applications.

MLX90367 provides SENT Frames encoded according the Throttle sensor format or Secure Sensor format. The circuit delivers enhanced serial messages providing error codes, and user-defined values.

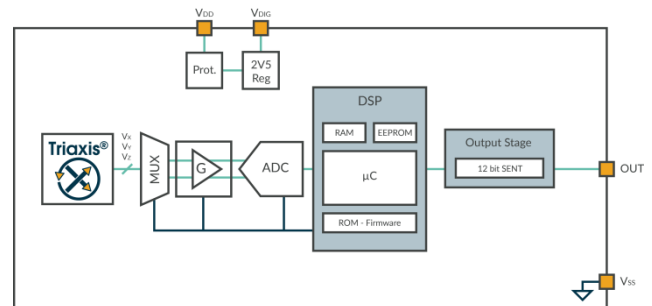

Contents

Features and Benefits.....	1
Applications.....	1
Description.....	1
1. Ordering Information	4
2. Functional Diagram	5
3. Glossary of Terms.....	5
4. Pinout.....	6
5. Absolute Maximum Ratings	6
6. Electrical Specification.....	7
7. Isolation Specification.....	8
8. Timing Specification.....	8
8.1. Timing diagrams.....	9
8.2. Application diagram used for rise and fall time measurement.....	10
9. Accuracy Specification	11
10. Magnetic Specification	12
11. CPU & Memory Specification.....	12
12. Traceability Information	12
13. End-User Programmable Items.....	13
14. SENT output Protocol	16
14.1. Generality.....	16
14.2. Throttle position / Single Secure Fast Channel	16
14.2.1. Frame Content.....	16
14.2.2. Diagnostic Reporting through the fast channel	16
14.3. Slow Channel.....	18
14.3.1. Enhanced Serial Message.....	18
14.3.2. Serial Message sequence	18
14.3.3. Serial message sequence period	19
14.3.4. Serial Message Error Code	20
14.4. Start-up	20
14.5. Field sensing (A2D conversions) and the frame Synchro pulse	20
15. Description of End-User Programmable Items.....	21

15.1. Output Transfer Characteristic	21
15.1.1. CLOCKWISE Parameter	21
15.1.2. Discontinuity Point (DP or Zero Degree Point).....	21
15.1.3. 3-Pts LNR Parameters (AxU version only)	22
15.1.4. 17-Pts LNR Parameters (AxV and AxX versions only).....	22
15.1.5. CLAMPING Parameters.....	24
15.1.6. Thermal Output Offset correction (AxX version only)	24
15.2. Identification	25
15.3. Lock.....	25
15.4. Sensor Front-End	25
15.4.1. MAPXYZ	25
15.4.2. SMISM, k and SEL_k Parameters	26
15.4.3. GAINMIN and GAINMAX Parameters	26
15.5. Filter	26
15.6. Diagnostic Features	27
15.7. EEPROM endurance.....	27
16. Self Diagnostic	28
17. Recommended Application Diagrams.....	30
17.1. MLX90367 in SOIC-8 Package	30
17.2. MLX90367 in TSSOP-16 Package.....	31
18. Standard information regarding manufacturability of Melexis products with different soldering processes.....	32
19. ESD Precautions.....	32
20. Package Information.....	33
20.1. SOIC-8 - Package Dimensions.....	33
20.2. SOIC-8 - Pinout and Marking.....	34
20.3. SOIC-8 - Sensitive spot positioning	34
20.4. TSSOP-16 - Package Dimensions.....	36
20.5. TSSOP-16 - Pinout and Marking.....	37
20.6. TSSOP-16 - Sensitive spot positioning	37
21. Disclaimer.....	39
22. Contact.....	39

1. Ordering Information

Product Code	Temperature Code	Package Code	Option Code	Packing Form Code	Comment
MLX90367	E	DC	ABU-000	RE	Not recommended for new design
MLX90367	K	DC	ABU-000	RE	Not recommended for new design
MLX90367	L	DC	ABU-000	RE	Not recommended for new design
MLX90367	E	GO	ABU-000	RE	Not recommended for new design
MLX90367	K	GO	ABU-000	RE	Not recommended for new design
MLX90367	L	GO	ABU-000	RE	Not recommended for new design
MLX90367	L	DC	ABV-000	RE	Not recommended for new design
MLX90367	L	GO	ABV-000	RE	Not recommended for new design
MLX90367	L	DC	ABX-000	RE	Not recommended for new design
MLX90367	L	GO	ABX-000	RE	Not recommended for new design
MLX90367	E	DC	ACU-000	RE	
MLX90367	K	DC	ACU-000	RE	
MLX90367	L	DC	ACU-000	RE	
MLX90367	E	GO	ACU-000	RE	
MLX90367	K	GO	ACU-000	RE	
MLX90367	L	GO	ACU-000	RE	
MLX90367	L	DC	ACV-000	RE	
MLX90367	L	GO	ACV-000	RE	
MLX90367	L	DC	ACX-000	RE	
MLX90367	L	GO	ACX-000	RE	

Legend:

Temperature Code:	E: from -40 Deg.C to 85 Deg.C K: from -40 Deg.C to 125 Deg.C L: from -40 Deg.C to 150 Deg.C
Package Code:	“DC” for SOIC-8 package “GO” for TSSOP-16 package (dual die)
Option Code:	Axx-xxx: Die version ABx-xxx: Not recommended for new design ACU-xxx: Standard version (3-pts LNR Parameters) ACV-xxx: Standard version with 17-Pts LNR Parameters ACX-xxx: Standard version with 17-Pts LNR Parameters and Thermal Output Offset correction xxx-000 – Standard
Packing Form:	“RE” for Reel
Ordering Example:	MLX90367LGO-ACX-000-RE

Table 1 – Legend

2. Functional Diagram

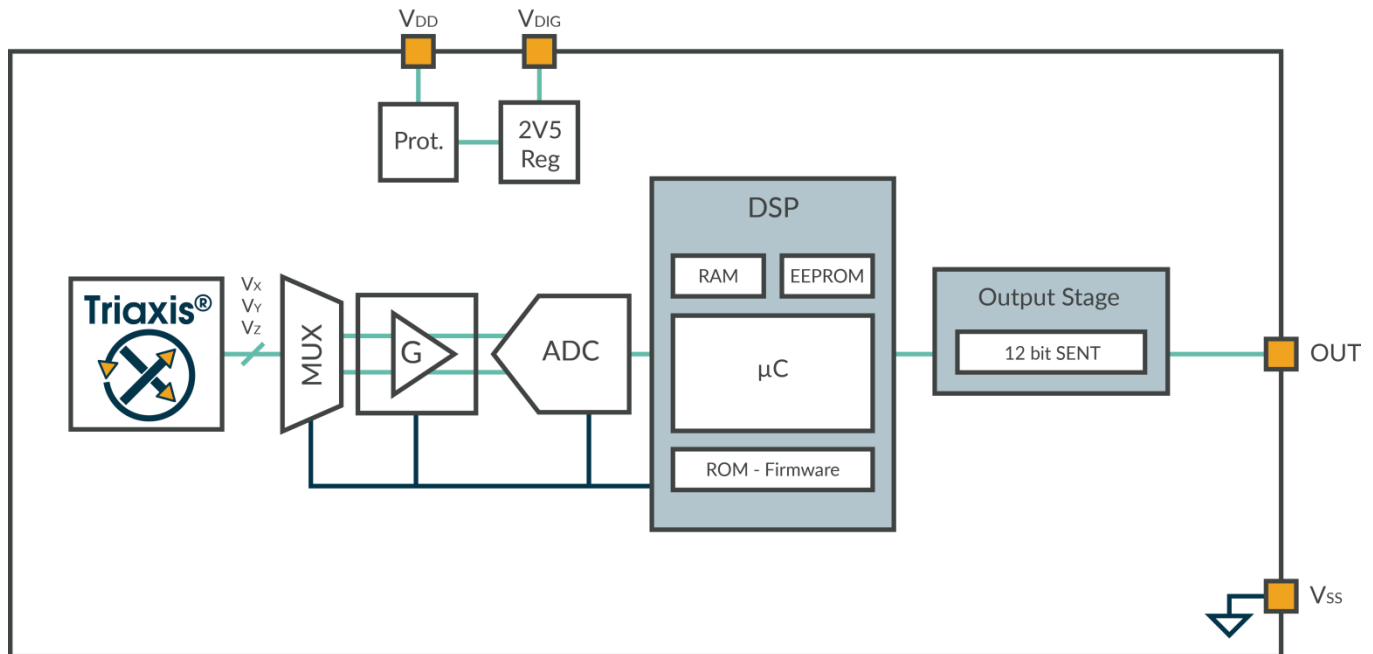

Figure 1 – Block Diagram

3. Glossary of Terms

Gauss (G), Tesla (T)	Units for the magnetic flux density - 1 mT = 10 G
TC	Temperature Coefficient (in ppm/Deg.C.)
NC	Not Connected
SENT	Single Edge Nibble Transmission
PWM	Pulse Width Modulation
ADC	Analog-to-Digital Converter
DAC	Digital to Analog Converter
LSB	Least Significant Bit
MSB	Most Significant Bit
DNL	Differential Non-Linearity
INL	Integral Non-Linearity
RISC	Reduced Instruction Set Computer
ASP	Analog Signal Processing
DSP	Digital Signal Processing

ATAN	Trigonometric function: arctangent (or inverse tangent)
IMC	Integrated Magneto-Concentrator (IMC®)
CoRDIC	Coordinate Rotation Digital Computer (i.e. iterative rectangular-to-polar transform)
EMC	Electro-Magnetic Compatibility
FE	Falling Edge
RE	Rising Edge
FW	Firmware
HW	Hardware
MT3V	More than 3V Condition
MT4V	More than 4V Condition
LSD	Low Side Driver = Open drain N
PP	Push-Pull

Table 2 – Glossary of Terms

4. Pinout

PIN	SOIC-8	TSSOP-16
1	VDD	V _{DIG1}
2	Test 0	V _{SS1} (Ground ₁)
3	Test 2	VDD ₁
4	Not Used	Test 0 ₁
5	OUT	Test 2 ₂
6	Test 1	OUT ₂
7	V _{DIG}	Not Used ₂
8	V _{SS} (Ground)	Test 1 ₂
9		V _{DIG2}
10		V _{SS2} (Ground ₂)
11		VDD ₂
12		Test 0 ₂
13		Test 2 ₁
14		Not Used ₁
15		OUT ₁
16		Test 1 ₁

For optimal EMC behavior, it is recommended to connect the unused pins (Test) to the Ground (see section 17).

5. Absolute Maximum Ratings

Parameter	Value
Supply Voltage, VDD (overvoltage)	+ 24 V
Reverse Voltage Protection	– 12 V (breakdown at -14 V)
Positive Output Voltage	+ 18 V (breakdown at 24 V)
Output Current (I _{OUT})	+ 30 mA (in breakdown)
Reverse Output Voltage	– 0.3 V
Reverse Output Current	– 50 mA (in breakdown)
Operating Ambient Temperature Range, T _A	– 40 ... + 150 Deg.C
Storage Temperature Range, T _S	– 40 ... + 150 Deg.C
Magnetic Flux Density	± 1 T

Exceeding the absolute maximum ratings may cause permanent damage. Exposure to absolute maximum-rated conditions for extended periods may affect device reliability.

6. Electrical Specification

DC Operating Parameters at Nominal Supply Voltage (unless otherwise specified) and for T_A as specified by the Temperature suffix (E, K or L).

Parameter	Symbol	Test Conditions	Min	Typ	Max	Units
Nominal Supply Voltage	VDD		4.5	5	5.5	V
Supply Current ⁽¹⁾	IDD	Power saving Enabled, all modes For Outmode=1		6	10 ⁽²⁾ 10	mA
Isurge Current ⁽³⁾	Isurge				20	mA
Power-On reset (rising)	HPOR_LH	Refer to internal voltage Vdig	2	2.25	2.5	V
Power-On reset Hysteresis	HPOR_Hyst		50		200	mV
Start-up Level (rising)	MT4V LH		3.8	4.0	4.2	V
Start-up Hysteresis	MT4V Hyst		50		200	mV
PTC Entry Level (rising)	MT7V_LH		5.8	6.2	6.6	V
PTC Entry Level Hysteresis	MT7V_Hyst		50		200	mV
Output Short Circuit Current	ISHORT	Vout = 0 V Vout = 5 V Vout = 18 V ($T_A = 25$ Deg.C)			15 15 18	mA mA mA
Output Load	RL	Pull-down to Ground Pull-up to 5V	1 1	10 10	∞ ∞	k Ω k Ω
Active Diagnostic Output Level	Dsat_lo	Pull-up load $R_L \geq 10$ k Ω to 5 V Pull-up load $R_L \geq 5$ k Ω to 18V		0.5 2	2 3	%VDD
Digital Saturation Output Level	Dsat_hi	Pull-down load $R_L \geq 5$ k Ω Pull-down load $R_L \geq 10$ k Ω	95 97.5	97 98.5		%VDD
Passive Diagnostic Output Level (Broken Track Diagnostic) ⁽⁴⁾	BVssPD ⁽⁵⁾	Broken Vss & Pull-down load $R_L \geq 5$ k Ω Pull-down load $R_L \geq 10$ k Ω	95 97.5			%VDD
	BVssPU	Broken Vss & Pull-up load $R_L \geq 4.7$ k Ω	99.5	100		%VDD
	BVDDPD	Broken VDD & Pull-down load $R_L \geq 4.7$ k Ω		0	0.5	%VDD
	BVDDPU	Broken VDD & Pull-up load $R_L \geq 5$ k Ω			2	%VDD
Digital output Ron	Ron	Diag_low Diag_hi	15 120		30 300	Ω

¹ Averaged current consumption, for the dual version, the supply current is multiplied by 2.

² To reach 10mA, the power saving option is enabled. This option switches off and on internal blocks dynamically. It can be disabled in case of extreme emission requirements; the maximum supply current consumption is then increased up to 12mA.

³ The specified value is valid during early start-up time only; the current might dynamically exceed the specified value, shortly, during the Start-up phase.

⁴ The SENT output signal will no longer be reported. For detailed information, see also section 0

⁵ In case the dual-die variant is used BVssPD level can be influenced. Refer to Technical note MLX90365_Broken_Vss_DualDie

7. Isolation Specification

DC Operating Parameters at Nominal Supply Voltage (unless otherwise specified) and for T_A as specified by the Temperature suffix (E, K or L). Only valid for the package code GO i.e. dual die version.

Parameter	Symbol	Test Conditions	Min	Typ	Max	Units
Isolation Resistance		Between dice	4			MΩ

8. Timing Specification

DC Operating Parameters at Nominal Supply Voltage (unless otherwise specified) and for T_A as specified by the Temperature suffix (E, K or L).

Parameter	Symbol	Test Conditions	Min	Typ	Max	Units
Main Clock Frequency	Ck	All contributors (trimming accuracy, supply voltage, thermal and ageing)	12.6	13.3	14	MHz
Main Clock Frequency Thermal Drift	ΔT_{Ck}				$\pm 3\%$	Ck _{NOM}
Tick time				3		μs
Low pulse tick count		Default EEPROM setting	4	5		ticks
SENT Frame Period	tframe			882		μs
Internal Angle Measurement Period	tper		Exact value for Ck = 13.3 MHz		441	
First Angle Measurement to Sync Pulse latency	ta1	The typical value will be affected by any variation of the clock		1084		μs
Second Angle Measurement to Sync Pulse latency	ta2			643		μs
Field Change to SENT Data: Average Latency	Latency		FILTER = 1 (recommended) SENT Transmission Included	1745		1745
SENT Frame Tick Count		Default EEPROM setting	294		294	
Watchdog	Twd		114.5	118	121.5	ms
Start-up Time (up to first sync pulse)	Tsu1			1.8		ms
Start-up Time (up to first data received)	Tsu2	Last pause pulse not included		5.9	6.3	ms
Serial Message		Extended sequence (40 frames) Short sequence (24 frames)		635.04 381.02		ms
Rise Time @ Cable		Thresholds: 0.5V and 4.5V See section 9.2	2.97		5.31	μs
Rise Time @ Receiver			5.07		6.84	μs
Fall Time @ Cable			2.65		2.82	μs
Fall Time @ Receiver			4.84		4.9	μs

8.1. Timing diagrams

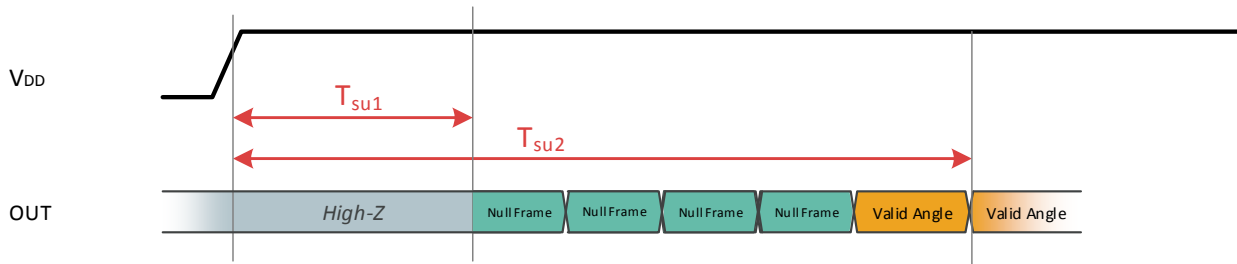

Figure 2 - Start-up phase timings

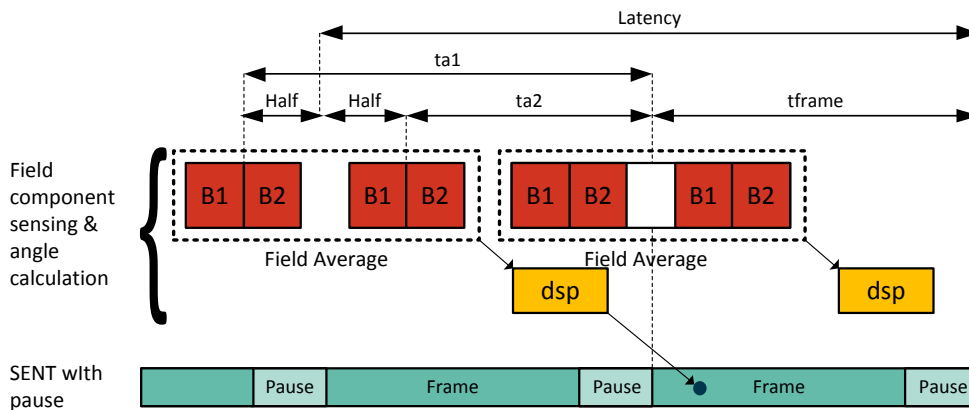

Figure 3 - Latencies (acquisition to output delays) – FILTER = 1 (recommended)

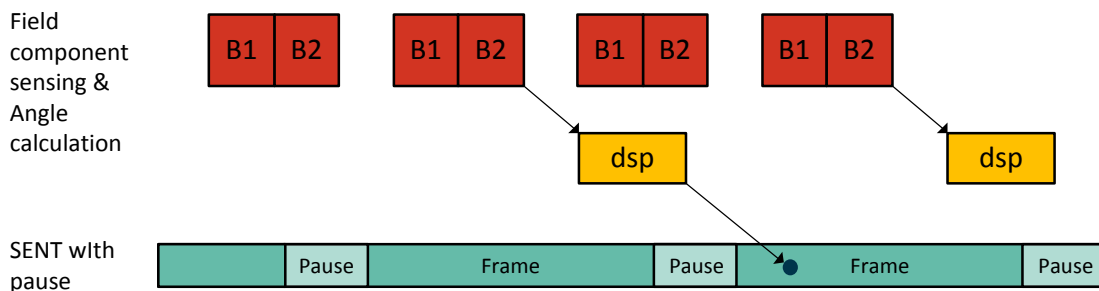

Figure 4 - Latency - Case FILTER = 0 (not recommended)

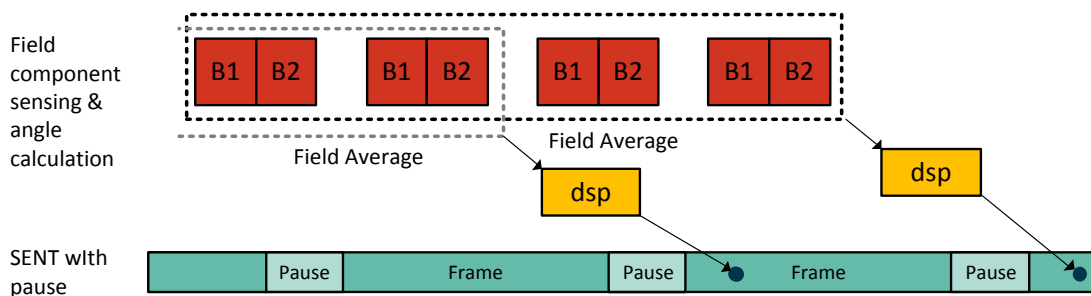

Figure 5 - Latency - Case FILTER = 2

8.2. Application diagram used for rise and fall time measurement

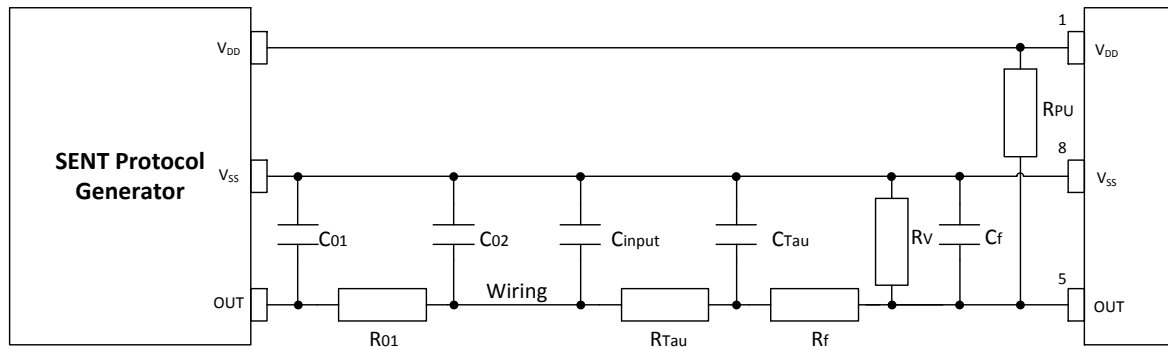

Figure 6 - Schematic used for rise and fall time measurements (ref: J2716 Rev Jan 2010 Fig. 6.3.4)

Component	Value	Unit
C01	10 ± 25%	nF
C02	not mounted	nF
R01	not mounted	Ω
Cinput	68	pF
CTau	2.2	nF
Cf	100	pF
RTau	568	Ω
Rf	10	kΩ
RPU	14.7	kΩ
RV	not mounted	Ω

Component values used for rise and fall time measurements (ref: J2716 Rev Jan 2010 Fig. 6.3.4)

9. Accuracy Specification

DC Operating Parameters at Nominal Supply Voltage (unless otherwise specified) and for T_A as specified by the Temperature suffix (E, K or L).

Parameter	Symbol	Test Conditions	Min	Typ	Max	Units
ADC Resolution on the raw signals sine and cosine ⁽⁶⁾	RADC			15		bits
Thermal Offset Drift #1 ⁽⁷⁾ at the DSP input (excl. DAC and output stage)		Temperature suffix E Temperature suffix K Temperature suffix L	-60 -60 -90		+60 +60 +90	LSB15
Thermal Drift of Sensitivity Mismatch ⁽⁸⁾		XY axis – Temp. suffix E XY axis – Temp. suffix K & L XZ (YZ) axis – Temp. suffix E XZ (YZ) axis – Temp. suffix K & L	-0.3 -0.5 -1 -1		+0.3 +0.5 +1 +1	%
Magnetic Angle phase error		$T_A = 25\text{Deg.C} - \text{XY axis}$ $T_A = 25\text{Deg.C} - \text{XZ axis}$ $T_A = 25\text{Deg.C} - \text{YZ axis}$	-0.3 -2 -2		0.3 2 2	Deg.
Thermal Drift of Magnetic Angle phase error		XY axis, XZ (YZ) axis		0.01		Deg.
XY – Intrinsic Linearity Error ⁽⁹⁾	Le	$T_A = 25\text{Deg.C} - \text{factory trim. "SMISM"}$	-1		1	Deg.
XZ - Intrinsic Linearity Error ⁽⁹⁾	Le	$T_A = 25\text{Deg.C} - \text{"k" trimmed for XZ}$	-2.5	± 1.25	+2.5	Deg.
YZ - Intrinsic Linearity Error ⁽⁹⁾	Le	$T_A = 25\text{Deg.C} - \text{"k" trimmed for YZ}$	-2.5	± 1.25	+2.5	Deg.
Noise pk-pk ⁽¹⁰⁾		Filter = 0; 40mT Filter = 1 (recommended); 30mT Filter = 2; 20mT		0.10 0.10 0.10	0.2 0.2 0.2	Deg.

⁶ 16 bits corresponds to 15 bits + sign. Internal computation is performed using 16 bits.

⁷ For instance, in case of a rotary position sensor application, Thermal Offset Drift #1 equal $\pm 60\text{LSB15}$ yields to max. ± 0.3 Deg. angular error for the computed angular information (output of the DSP). This is only valid if $k = 1$.

⁸ For instance, in case of a rotary position sensor application, Thermal Drift of Sensitivity Mismatch equal $\pm 0.5\%$ yields to max. ± 0.15 Deg. angular error for the computed angular information (output of the DSP).

⁹ The Intrinsic Linearity Error refers to the IC itself (offset, sensitivity mismatch, orthogonality) taking into account an ideal rotating field for B_X and B_Y . Once associated to a practical magnetic construction and the associated mechanical and magnetic tolerances, the output linearity error increases. However, it can be improved with the multi-point end-user calibration. The intrinsic Linearity Error for Magnetic angle $\angle XZ$ and $\angle YZ$ can be reduced through the programming of the k factor.

¹⁰ Noise pk-pk (peak-to-peak) is here intended as 6 times the Noise standard Deviation. The application diagram used is described in the recommended wiring. For detailed information, refer to section Filter in application mode (Section 15.5).

10. Magnetic Specification

DC Operating Parameters at Nominal Supply Voltage (unless otherwise specified) and for TA as specified by the Temperature suffix (E, K or L).

Parameter	Symbol	Test Conditions	Min	Typ	Max	Units
Magnetic Flux Density	$B_x, B_y^{(11)}$	$\sqrt{B_x^2 + B_y^2}$			70 ⁽¹²⁾	mT
Magnetic Flux Density	B_z				126	mT
Magnetic Flux Norm	Norm	$\sqrt{B_x^2 + B_y^2 + (B_z/1.2)^2}$	20 ⁽¹³⁾			mT
IMC Gain in X and Y ⁽¹⁴⁾	GainIMC _{XY}		1.2	1.4	1.8	
IMC Gain in Z	GainIMC _Z		1.1		1.3	
k factor	k	GainIMC _{XY} / GainIMC _Z	1	1.2	1.5	
Magnet Temperature Coefficient	TCm		-2400		0	ppm/Deg.C

11. CPU & Memory Specification

The DSP is based on a 16 bit RISC μ Controller. This CPU provides 2.5 MIPS while running at 10 MHz.

Parameter	Symbol	Test Conditions	Min	Typ	Max	Units
ROM				10		KB
RAM				384		B
EEPROM				128		B

12. Traceability Information

Every device contains a unique ID that is programmed by Melexis in the EEPROM. Melexis strongly recommends storing this value during the EOL (End-Of-Line) programming to ensure full traceability of the final product. These parameters shall never be erased during the EOL programming.

Parameter	Comments	Default Values	Parameter # bit
MELEXISID1	Melexis identification reference	MLX	16
MELEXISID2	Melexis identification reference	MLX	16
MELEXISID3	Melexis identification reference	MLX	16

¹¹ The condition must be fulfilled for at least one field B_x or B_y .

¹² Above 70 mT, the IMC starts saturating yielding to an increase of the linearity error.

¹³ Below 20 mT, the performances slightly degrade due to a reduction of the signal-to-noise ratio, signal-to-offset ratio.

¹⁴ This is the magnetic gain linked to the Integrated Magneto Concentrator structure. This is the overall variation. Within one lot, the part to part variation is typically $\pm 10\%$ versus the average value of the IMC gain of that lot.

13. End-User Programmable Items

Parameter	Comments	AxU-xxx		AxV-xxx		AxX-xxx	
		#bit	Std	#bit	Std	#bit	Std
MAPXYZ	Mapping fields for output angle	2	0x0	2	0x0	2	0x0
CLAMPHIGH	Clamping High	16	0xFF80	16	0xFFFF	16	0xFF80
CLAMPLOW	Clamping Low	16	0x0010	16	0x0000	16	0x0010
SMISM	Sensitivity mismatch factor X, Y	15	MLX	15	MLX	15	MLX
K	Sensitivity mismatch factor X (Y), Z	15	MLX	15	MLX	15	MLX
SELK	Location for K – correction	1	0x0	1	0x0	1	0x0
GAINMIN	Low threshold for virtual gain	8	0x00	8	0x00	8	0x01
GAINMAX	High threshold for virtual gain	8	0x28	8	0x28	8	0x28
GAINSATURATION	Gain Saturates on GAINMIX and GAINMAX	1	0x0	1	0x0	1	0x0
DP	Discontinuity point	15	0x0000	15	0x0000	15	0x0000
CW	Clock Wise	1	0x0	1	0x0	1	0x0
LNRS0	3pts – Initial Slope	16	0x0000		N/A		N/A
LNRAX	3pts – AX Coordinate	16	0x0000		N/A		N/A
LNRAY	3pts – AY Coordinate	16	0x0010		N/A		N/A
LNRAS	3pts – AS Coordinate	16	0x1FF0		N/A		N/A
LNRBX	3pts – BX Coordinate	16	0xFFFF		N/A		N/A
LNRBY	3pts – BY Coordinate	16	0xFFFF		N/A		N/A
LNRBS	3pts – BS Coordinate	16	0x0000		N/A		N/A
LNRCS	3pts – CS Coordinate	16	0x0000		N/A		N/A
DIAGSETTINGS	16 Bit Diagnostics enabling	16	0x4080	16	0x4080	16	0x4080
CRCDISABLE	Enable EEPROM CRC check (0x0000=enabled)	16	0x0000	8	0x00	8	0x00
SERIALERROR	Diagnostic reporting through fast channel	3	0x0	3	0x0	3	0x0
FILTER	FIR Filter	2	0x0	2	0x0	2	0x0
SENTSERIAL	Serial Message	8	0x80	8	0x80	8	0x80
SERIAL_OEM1	Serial Message (12 lsb are used)	16	0x0000	12	0x000	12	0x000
SERIAL_OEM2	Serial Message (12 lsb are used)	16	0x0000	12	0x000	12	0x000

Parameter	Comments	AxU-xxx		AxV-xxx		AxX-xxx	
		#bit	Std	#bit	Std	#bit	Std
SERIAL_OEM3	Serial Message (12 lsb are used)	16	0x0000	12	0x000	12	0x000
SERIAL_OEM4	Serial Message (12 lsb are used)	16	0x0000	12	0x000	12	0x000
SERIAL_OEM5	Serial Message (12 lsb are used)	16	0x0000		N/A		N/A
SERIAL_OEM6	Serial Message (12 lsb are used)	16	0x0000		N/A		N/A
SERIAL_OEM7	Serial Message (12 lsb are used)	16	0x0000		N/A		N/A
SERIAL_OEM8	Serial Message (12 lsb are used)	16	0x0000		N/A		N/A
SERIAL_MANCODE	Serial Message (12 lsb are used)	16	0x0000	16	0x0000	16	0x0000
SERIAL_SensorType	Serial Message	12	0x000	12	0x000	12	0x000
SERIAL_SENTREV	Serial Message	4	0x3	4	0x3	4	0x3
USERID1	Cust identification reference: Default = Bin1 Can be used as incoming inspection, only set when final test was PASS.	16	0x0001		N/A		N/A
USERID2	Cust identification reference: Default Rev nr	16	0x0305		N/A		N/A
USERID3	Cust identification reference: Default Sens.	16	MLX		N/A		N/A
SERIAL_ID1	Serial data for serial 29 (12 lsb are used)	16	0x0000	12	0x000	12	0x000
SERIAL_ID2	Serial data for serial 2A (12 lsb are used)	16	0x0000	12	0x000	12	0x000
SERIAL_ID3	Serial data for serial 2B (12 lsb are used)	16	0x0000	12	0x000	12	0x000
SERIAL_ID4	Serial data for serial 2C (12 lsb are used)	16	0x0000	12	0x000	12	0x000
SERIALID1	ID of user serial message #1		N/A		N/A		N/A
SERIALID2	ID of user serial message #2		N/A		N/A		N/A
SERIALID3	ID of user serial message #3		N/A		N/A		N/A
SERIALID4	ID of user serial message #4		N/A		N/A		N/A
SLOW_MESSAGE	Enable or disable the serial message	1	0x1	1	0x1	1	0x1
PAUSEPULSE	Enable or disable the pause pulse	1	0x1	1	0x1	1	0x1
CRC2010	CRC according 2010 or 2007 standard	1	0x1	1	0x1	1	0x1
MEMLOCK	EEPROM memory lock	2	0x0	2	0x0	2	0x0
SERIALDATA1	Data of user serial message #1 (12 lsb used) Not available to USER until MemLock performed. For more details, see: EEPROM_MLX90366_default_settings.doc		N/A		N/A		N/A
SERIALDATA2	Data of user serial message #2 (12 lsb used)		N/A		N/A		N/A
SERIALDATA3	Data of user serial message #3 (12 lsb used)		N/A		N/A		N/A
SERIALDATA4	Data of user serial message #4 (12 lsb used)		N/A		N/A		N/A

Parameter	Comments	AxU-xxx		AxV-xxx		AxX-xxx	
		#bit	Std	#bit	Std	#bit	Std
SERIAL_X1	Serial Message (12 lsb used)	16	0x0000	12	0x000	12	0x000
SERIAL_X2	Serial Message (12 lsb used)	16	0x0000	12	0x000	12	0x000
SERIAL_Y1	Serial Message (12 lsb used)	16	0x0000	12	0x000	12	0x000
SERIAL_Y2	Serial Message (12 lsb used)	16	0x0000	12	0x000	12	0x000
W	17pts – Output angle range		N/A	4	0x0	4	0x0
LNR0	Y coordinate point 0/16		N/A	16	0x4001	16	0x4009
LNR1	Y coordinate point 1/16		N/A	16	0x4801	16	0x4804
LNR2	Y coordinate point 2/16		N/A	16	0x5001	16	0x5000
LNR3	Y coordinate point 3/16		N/A	16	0x5801	16	0x57FC
LNR4	Y coordinate point 4/16		N/A	16	0x6001	16	0x5FF8
LNR5	Y coordinate point 5/16		N/A	16	0x6801	16	0x67F4
LNR6	Y coordinate point 6/16		N/A	16	0x7001	16	0x6FF0
LNR7	Y coordinate point 7/16		N/A	16	0x7801	16	0x77EC
LNR8	Y coordinate point 8/16		N/A	16	0x8001	16	0x7FE8
LNR9	Y coordinate point 9/16		N/A	16	0x8801	16	0x87E4
LNR10	Y coordinate point 10/16		N/A	16	0x9001	16	0x8FE0
LNR11	Y coordinate point 11/16		N/A	16	0x9801	16	0x97DC
LNR12	Y coordinate point 12/16		N/A	16	0xA001	16	0x8FD8
LNR13	Y coordinate point 13/16		N/A	16	0xA801	16	0xA7D4
LNR14	Y coordinate point 14/16		N/A	16	0xB001	16	0xAFD0
LNR15	Y coordinate point 15/16		N/A	16	0xB801	16	0xB7CC
LNR16	Y coordinate point 16/16		N/A	16	0xC001	16	0xBFC8
ANGLEOFSSLOPECOLD	Temperature coefficient offset at cold temperatures		N/A		N/A	8	0x0
ANGLEOFSSLOPEHOT	Temperature coefficient offset at hot temperatures		N/A		N/A	8	0x0

Melexis strongly recommends checking the User Identification data (Parameters USERID) during EOL programming.

14. SENT output Protocol

14.1. Generality

The MLX90367 complies with the sub-set of the norm J2716 Revised JAN2010, “A.1 A.1 Throttle Position” or “A.3 Single Secure Sensors”

14.2. Throttle position / Single Secure Fast Channel

The MLX90367 delivers SENT frames according the Throttle position or Single Secure format. This format is explicitly described in this section.

14.2.1. Frame Content

The MLX90367 SENT frames have 6 data nibbles and are formatted according the below tables.

Single Secure									
	Nibble 0	Nibble 1	Nibble 2	Nibble 3	Nibble 4	Nibble 5	Nibble 6	Nibble 7	
SENT Frame :	Status	CH1-MSN	CH1-MidN	CH1-LSN	RC-MSN	RC-LSN	CCH1-MSN	CRC	Optional Pause
optional error code		F	F	8+EE_REPORT			0		

- Status[0] Channel 1 indicator ("1" = error, "0" otherwise)
- Status[1] 0
- Status[2] Enhanced Serial Message (dissable option)
- Status[3] Enhanced Serial Message (dissable option)
- CRC Enhanced CRC (the legacy CRC is optional)
- Ch1 12 bit angle
- RC 8 bit rolling counter
- CCH1 Inverted Copy Ch1

Throttle position									
	Nibble 0	Nibble 1	Nibble 2	Nibble 3	Nibble 4	Nibble 5	Nibble 6	Nibble 7	
SENT Frame :	Status	CH1-MSN	CH1-MidN	CH1-LSN	CH2-LSN	CH2-MidN	CH2-MSN	CRC	Optional Pause
optional error code		F	F	8+EE_REPORT	F	F	8+EE_REPORT		

- Status[0] Channel 1 indicator ("1" = error, "0" otherwise)
- Status[1] Channel 2 indicator ("1" = error, "0" otherwise)
- Status[2] Enhanced Serial Message (dissable option)
- Status[3] Enhanced Serial Message (dissable option)
- CRC Enhanced CRC (the legacy CRC is optional)
- Ch1 12 bit angle
- Ch2 12 bit angle = Inverted CH1 (optional : FFF-CH1 or FF9-CH1)

14.2.2. Diagnostic Reporting through the fast channel

Diagnostic Reporting, bit Status[0]

The bit Status[0] is high whenever the three following conditions are met:

1. A diagnostic (analog/environmental) detects an error⁽¹⁵⁾
2. The reporting of the above error is enabled⁽¹⁶⁾
3. The debouncing time has elapsed.

Diagnostic Reporting, Channel 1

The diagnostic can be reported through the 12 bit payload of channel 1, and not only through the status bit Status[0]. The EEPROM parameters SERIALERROR controls the diagnostic reporting through channel 1 as follow:

If SERIALERROR =0, the channel 1 reports the angle, and not the diagnostic, as if no diagnostic.

The error is reported only thanks to the Status bits.

If SERIALERROR >0, the channel 1 payload contains the value Channel1 = (4088 + SERIALERROR)]

Diagnostic Reporting Time

The Diagnostic Reporting Time is programmable (defined as multiple of a macro-cycle unit time).

A macro-cycle is a sequence of 20 angle acquisitions and has duration of approximately 6ms.

Diagnostic Debouncing

The Diagnostic Reporting is debounced. The debouncing parameters are user-programmable, by steps of approximately 6 ms.

Pause pulse

A pause pulse, as defined by the standard, is present at the end of every frame. The pause pulse mode can be disabled. Please contact our Direct Sales team to obtain the complete procedure for deactivating the pause pulse mode. The pause pulse length is adjusted by the circuit so that the frame period is constant.

The field sensing and the frame synchronization pulse are in sync.

Fast Channel CRC

The MLX90367 features the new recommended implementation and optional the legacy implementation

¹⁵ A diagnostic of type digital cause the circuit to switch in fail-safe-mode

¹⁶ See EEPROM bits EE_DIAG_SETTINGS

14.3. Slow Channel

14.3.1. Enhanced Serial Message

The circuit encodes the slow messages according the Enhanced Serial Message Format as specified at Chapter 5.2.4.3 of the SENT norm, except for the following restriction:

The configuration bit is always 0, meaning that the payload consists in 12-bit data and 8-bit message ID.

14.3.2. Serial Message sequence

The circuit complies with the following sub-set specifications of the norm for pressure sensors

(The norm for the angular sensor case does not specify the serial message format)

ID	Item	12 bit data	Comment	AxU		AxV & AxX	
				#	Optional part	#	Optional part
1	Diagnostic error codes	RAM	cf section 14.3.4	1		1	
6	SENT standard revision	Prog.	EEPROM: SERIAL_SENTREV	2		2	
1	Diagnostic error codes	RAM		3		3	
5	Manufacturer code	Prog.	EEPROM: SERIAL_MANCODE	4		4	
1	Diagnostic error codes	RAM		5		5	
3	Channel 1 / 2 sensor type	Prog.	EEPROM: SERIAL_SensorType	6		6	
1	Diagnostic error codes	RAM		7		7	
7	Fast channel 1 - X1	Prog.	EEPROM: SERIAL_X1	8		8	
1	Diagnostic error codes	RAM		9		9	
8	Fast channel 1 - X2	Prog.	EEPROM: SERIAL_X2	10		10	
1	Diagnostic error codes	RAM		11		11	
9	Fast channel 1 - Y1	Prog.	EEPROM: SERIAL_Y1	12		12	
1	Diagnostic error codes	RAM		13		13	
A	Fast channel 1 - Y2	Prog.	EEPROM: SERIAL_Y2	14		14	
1	Diagnostic error codes	RAM		15		15	
23	Temperature sensor	Prog.		16		16	
1	Diagnostic error codes	RAM		17		17	
29	Sensor ID #1	Prog.	EEPROM: SERIAL_ID1	18		18	
1	Diagnostic error codes	RAM		19		19	
2A	Sensor ID #2	Prog.	EEPROM: SERIAL_ID2	20		20	
1	Diagnostic error codes	RAM		21		21	
2B	Sensor ID #3	Prog.	EEPROM: SERIAL_ID3	22		22	
1	Diagnostic error codes	RAM		23		23	
2C	Sensor ID #4	Prog.	EEPROM: SERIAL_ID4	24		24	
1	Diagnostic error codes	RAM		25	X	25	X
90	OEM Code #1	Prog.	EEPROM: SERIAL_OEM1	26	X	26	X
1	Diagnostic error codes	RAM		27	X	27	X
91	OEM Code #2	Prog.	EEPROM: SERIAL_OEM2	28	X	28	X
1	Diagnostic error codes	RAM		29	X	29	X

ID	Item	12 bit data	Comment	AxU		AxV & AxX	
				#	Optional part	#	Optional part
92	OEM Code #3	Prog.	EEPROM: SERIAL_OEM3	30	X	30	X
1	Diagnostic error codes	RAM		31	X	31	X
93	OEM Code #4	Prog.	EEPROM: SERIAL_OEM4	32	X	32	X
1	Diagnostic error codes	RAM		33	X	NA	
94	OEM Code #5	Prog.	EEPROM: SERIAL_OEM5	34	X	NA	
1	Diagnostic error codes	RAM		35	X	NA	
95	OEM Code #6	Prog.	EEPROM: SERIAL_OEM6	36	X	NA	
1	Diagnostic error codes	RAM		37	X	NA	
96	OEM Code #7	Prog.	EEPROM: SERIAL_OEM7	38	X	NA	
1	Diagnostic error codes	RAM		39	X	NA	
97	OEM Code #8	Prog.	EEPROM: SERIAL_OEM8	40	X	NA	

Table 3 - Serial Message Sequence

The first part (positions 1 to 24) provides the Error Code and the Sensor ID alternatively.

The second part (positions 25 to 40) is optional and enabled with EEPROM bit(EE_ExtendedSequence=1).. This second part consists of the error code (8 occurrences), and 8 OEM -defined Code

The temperature can be derived from SENT ID 23, TEMP sensor, with the following equation:

$$\text{SENT@ ID 23} = 8 * (T[C] - 35[C]) + 865 \text{ LSB}_{12}$$

The accuracy of the actual Temperature is around ± 10 Deg.C.

14.3.3. Serial message sequence period

Sequence Length (serial message count)	Sequence Length (frame count)	Sequence Period (ms, typical)
8	144	127
24	432	381
32	576	509
40	720	636

Error Code Rate

The Error Code are on purpose transmitted every second message, to maximize the rate, which equals then 36 SENT frames.

14.3.4. Serial Message Error Code

The list of error and status messages transmitted in the 12-bit Enhanced Serial Message data field when Enhance Serial Message ID is \$01 is given in the following Table.

12 Bit Data	Diagnostic	Comments
\$000	No error	
\$801	GainOOS	Front-end Gain code Out-of-spec (too low, too high)
\$808	ADCSatura	Diag
\$810	ADCMonitor	ADC monitor
\$820	VanaMoni	Analog Internal Supply Too Low
\$840	VddMoni	External Supply Too Low
\$880	Rough Offset	Front-end Rough Offset too low, too high
\$900	TempMonitor	Temperature Sensor monitor

In case multiple errors occur, then the resulting 12 bit enhanced serial message data will be the OR-operation of the individual data values. Example \$809 = GainOOS + ADCsatura

14.4. Start-up

During the chip initialization, the output remains high until the circuit emits four initialization frames (all 6 data nibbles are zero). The fifth frame is not an initialization frame but a valid frame containing a measured angle. See also section 8 “Timing Specification”. The first four frames conform to the SENT specification and include a valid CRC.

14.5. Field sensing (A2D conversions) and the frame Synchro pulse

By default setting of the Timer period and Filter =1, the digital angle (fast channel payload) results of the average of two angles. These angles are themselves computed from 4 ADCs values.

The time between the ADCs and the frame synchronization pulse is constant.

As a result, the phase delay between the magnetic field angle and the SENT synchronization pulse is constant, allowing filtering at the ECU side.

See also section 8 “Timing Specification”

15. Description of End-User Programmable Items

15.1. Output Transfer Characteristic

To define the transfer function (LNR):

Parameter	Comments	Value	Unit
CW	For all versions	0 : CounterClockWise 1 : ClockWise	LSB
DP	For all versions	0...359.9999	Deg.
CLAMPLOW	For all versions	0 ... 100	%
CLAMPHIGH	For all versions	0 ... 100	%
LNRAX, LNRBX, LNRXC	3pts LNR only	0 ... 359.9999	Deg.
LNRAY, LNRBY, LNRCY	3pts LNR only	0 ... 100	%
LNR50, LNRAS, LNRBS, LNRCS	3pts LNR only	-17... 0 ... 17	%/Deg.
LNR0...LNR16	17pts LNR only	-50 ...+150	%
ANGLEOFSSLOPECOLD	Thermal Ouput Offset correction only	0..255	LSB In %/ Deg.C
ANGLEOFSSLOPEHOT	Thermal Ouput Offset correction only	0..255	LSB In %/ Deg.C

15.1.1. CLOCKWISE Parameter

The CLOCKWISE parameter defines the magnet rotation direction.

- CCW is the defined by the 1-4-5-8 pin order direction for the SOIC-8 package and 1-8-9-16 pin order direction for the TSSOP-16 package.
- CW is defined by the reverse direction: 8-5-4-1 pin order direction for the SOIC-8 and 16-9-8-1 pin order direction for the TSSOP-16 package.

Refer to the drawing in the sensitive spot positioning sections (Section 20.3 and 20.6).

15.1.2. Discontinuity Point (DP or Zero Degree Point)

The Discontinuity Point defines the 0Deg. point on the circle. The discontinuity point places the origin at any location of the trigonometric circle. The DP is used as reference for all the angular measurements.

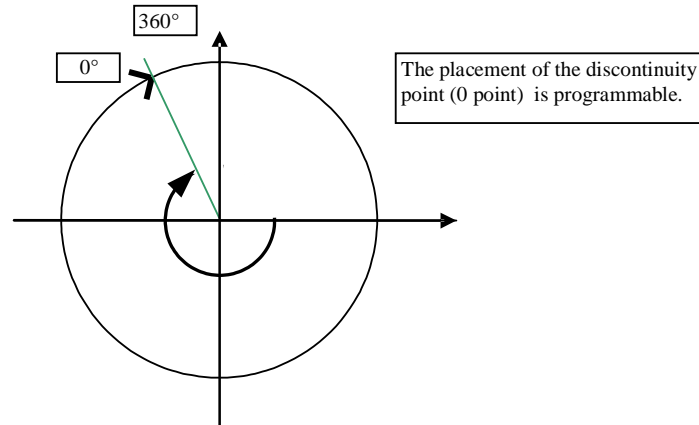

Figure 7 - Discontinuity Point Positioning

15.1.3. 3-Pts LNR Parameters (AxU version only)

The LNR parameters, together with the clamping values, fully define the relation (the transfer function) between the digital angle and the output signal.

The shape of the MLX90367 transfer function from the digital angle value to the output voltage is described by the drawing below. Six segments can be programmed but the clamping levels are necessarily flat.

Two, three, or even five calibration points are then available, reducing the overall non-linearity of the IC by almost an order of magnitude each time. Three or five point calibration will be preferred by customers looking for excellent non-linearity figures. Two-point calibrations will be preferred by customers looking for a cheaper calibration set-up and shorter calibration time.

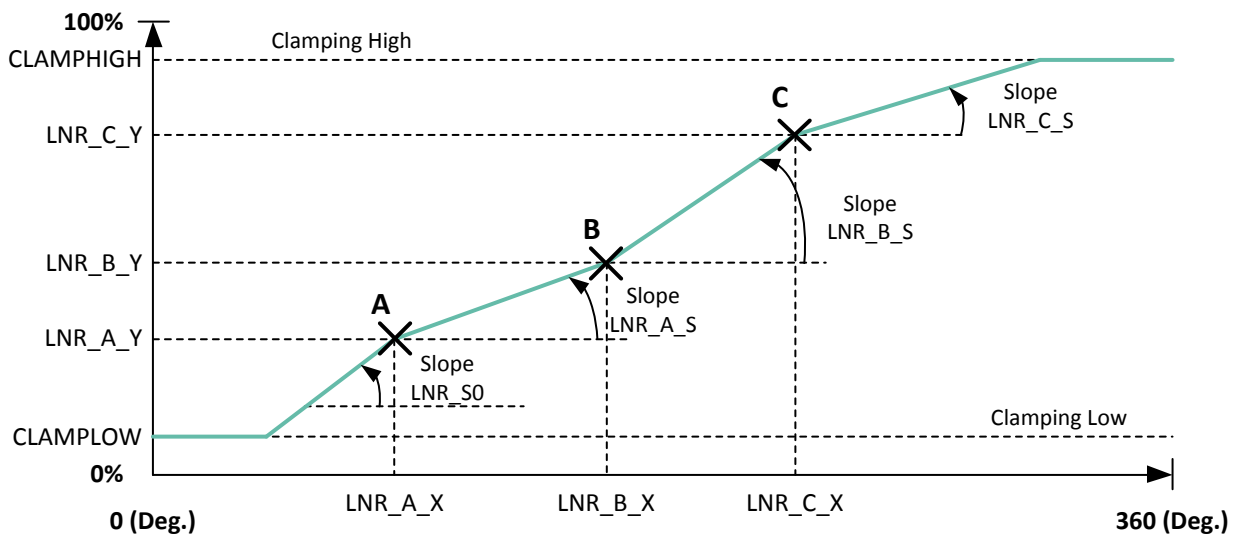

Figure 8 - 3-Pts LNR Parameters

15.1.4. 17-Pts LNR Parameters (AxV and AxX versions only)

The LNR parameters, together with the clamping values, fully define the relation (the transfer function) between the digital angle and the output signal.

The shape of the MLX90367 transfer function from the digital angle value to the output voltage is described by the drawing below. In the 17-Pts mode, the output transfer characteristic is Piece-Wise-Linear (PWL).

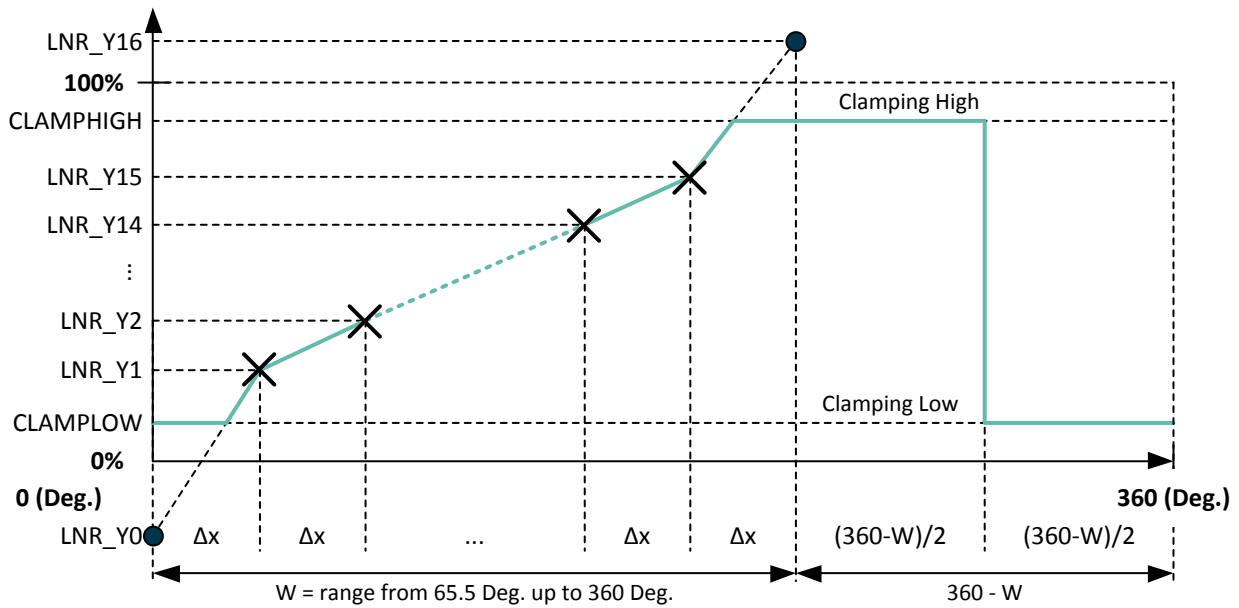

Figure 9 - Input range from 65.5Deg. up to 360Deg.

All the Y-coordinates can be programmed from -50% up to +150% to allow clamping in the middle of one segment (like on the Figure 9), but the output value is limited to CLAMPLOW and CLAMPHIGH values.

Between two consecutive points, the output characteristic is interpolated.

The parameter W determines the input range on which the 17 points (16 segments) are uniformly spread:

W	Range	Δx
0 (0000b)	360.0Deg.	22.5Deg.
1	320.0Deg.	20.0Deg.
2	288.0Deg.	18.0Deg.
3	261.8Deg.	16.4Deg.
4	240.0Deg.	15.0Deg.
5	221.5Deg.	13.8Deg.
6	205.7Deg.	12.9Deg.
7	192.0Deg.	12.0Deg.

W	Range	Δx
8	180.0Deg.	11.3Deg.
9	144.0Deg.	9.0Deg.
10	120.0Deg.	7.5Deg.
11	102.9Deg.	6.4Deg.
12	90.0Deg.	5.6Deg.
13	80.0Deg.	5.0Deg.
14	72.0Deg.	4.5Deg.
15 (1111b)	65.5Deg.	4.1Deg.

Outside of the selected range, the output will remain in clamping levels.

15.1.5. CLAMPING Parameters

The clamping levels are two independent values to limit the output voltage range. The CLAMPLOW parameter adjusts the minimum output voltage level. The CLAMPHIGH parameter sets the maximum output voltage level. Both parameters have 16 bits of adjustment and are available for both LNR modes.

15.1.6. Thermal Output Offset correction (AxX version only)

On the AxX version, the two parameters ANGLEOFSSLOPEHOT and ANGLEOFSSLOPECOLD, defined in the section End-User Programmable Parameters, enable adding an offset to the output dependent on the measured temperature (see the Figure 10).

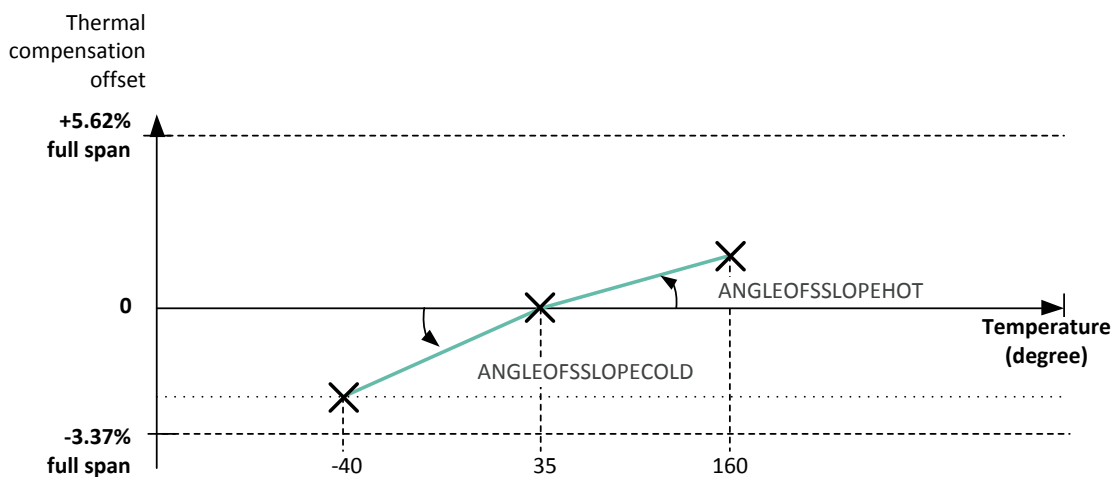

Figure 10 - Input range from -40Deg.C up to 160 Deg.C

The thermal offset is added before the clamping (see section 15.1.5). The span of this offset is +5.62/-3.37% of the full output scale. The added thermal offset varies with temperature see the equation below and the thermal coefficient is defined separately before (used coefficient ANGLEOFSSLOPECOLD) and after 35Deg.C (used coefficient ANGLEOFSSLOPEHOT).

If the temperature is higher than 35 Deg.C then: $output \leq output - \Delta T * ANGLEOFSSLOPEHOT$

If the temperature is lower than 35 Deg.C then: $output \leq output - \Delta T * ANGLEOFSSLOPECOLD$

Where output is the calculated output adjusted by the thermal correction offset $\Delta T * ANGLEOFSSLOPECOLD$. Where ΔT is the difference between the current temperature and the reference temperature 35Deg.C. The output correction capability at hot and room (extreme temperature and maximum value of ANGLEOFSSLOPEHOT and ANGLEOFSSLOPECOLD) are given in the table below.

Parameter	Min	Typ	Max	Unit
Output correction capability at 160Deg.C	5%	5.62%		of Full span
Output correction capability at -40Deg.C	-3.09%	-3.37%		of Full span

15.2. Identification

Parameter	Comments	Value
USERID1	For AxU-xxx version only	0...65535
USERID2		0...65535
USERID3		0...65535

Identification number: 48 bits (3 words) freely useable by Customer for traceability purpose.

15.3. Lock

The MEMLOCK write protects all the EEPROM parameters set by the Melexis and user. Once the lock is enabled, it is not possible to change the EEPROM values anymore.

Note that the Memlock bits should be set by the solver function "MemLock".

15.4. Sensor Front-End

Parameter	Value
MAPXYZ	0 ... 3
SMISM	0 ... 32768
k	0 ... 32768
SEL_k	0 or 1
GAINMIN	0 ... 41
GAINMAX	0 ... 41
GAINSATURATION	0 ... 1

15.4.1. MAPXYZ

The MAPXYZ parameter defines which fields are used to calculate the angle. The different possibilities are described in the tables below.

This 2 bit value selects the first (B1) and second (B2) field components according the table below.

MAPXYZ	B1	B2	Angular
0 – 00b	X	Y	XY mode
1 – 01b	Zx	X	XZx mode
2 – 10b	Y	Zx	YZx mode

Note: MAPXYZ = 3 is not recommended.

15.4.2. SMISM, k and SEL_k Parameters

(i) SMISM

When the mapping (B1=X, B2=Y) is selected, SMISM defines the sensitivity mismatch factor that is applied on B1 or B2; When another B1, B2 mapping is selected, this parameter is “don’t care”.

This parameter is trimmed at factory; Melexis strongly recommends TO NOT overwrite it for optimal performances.

(ii) K

When the mapping (B1=X, B2=Y) is **NOT** selected, k defines the sensitivity mismatch factor that is applied on B1 or B2 (according to parameter SELK – see below). When the mapping (B1=X, B2=Y) is selected, this parameter is “don’t care”.

This parameter is trimmed at factory for mapping (B1=Z, B2=X). Melexis recommends to fine trim it when a smaller linearity error (Le) is required and a different mapping than (B1=X, B2=Y) is selected.

(iii) SELK

When the mapping (B1=X, B2=Y) is **NOT** selected, SELK defines the component on which the sensitivity mismatch factor k (see above): SELK = 0 means B1 → k · B1 and SELK = 1 means B2 → k · B2.

15.4.3. GAINMIN and GAINMAX Parameters

GAINMIN and GAINMAX define the thresholds on the gain code outside which the fault “GAIN out of Spec.” is set.

If GAINSATURATION is set, then the virtual gain code is saturated at GAINMIN and GAINMAX, and no Diagnostic fault is set since the saturations applies before the diagnostic check.

15.5. Filter

Parameter	Value
FILTER	0...2

The MLX90367 features a filter that is enabled when FILTER = 1 or 2. Filter = 0 corresponds to no filtering. The transfer function is described below:

$$y_n = \frac{1}{\sum_{i=0}^j a_i} \sum_{i=0}^j a_i x_{n-i}$$

The filters characteristic is given in the following table:

Filter	0	1	2
J No	0	1	3
Type	Disable	Finite Impulse Response	
Coefficients ai	1	11	1111
Title	No filter	ExtraLight	Light
99% Response Time	1	2	4
Efficiency RMS (dB)	0	3.0	6.0

15.6. Diagnostic Features

It is recommended to enable the diagnostic features for safety critical applications.

Refer to [Application_note_Diagnostic_Behavior_90367](#) for EE_CRC_Enable function description and for Diagnostic features which can be enabled by user.

15.7. EEPROM endurance

Although the EEPROM is used for Calibration Data Storage (similarly to an OTPROM), the MLX90367 embedded EEPROM is qualified to guarantee a minimum endurance of 1000 write cycles at 125°C for (engineering/calibration purpose).

16. Self Diagnostic

The MLX90367 provides numerous self-diagnostic features. Those features increase the robustness of the IC functionality as it will prevent the IC to provide erroneous output signal in case of internal or external failure modes (“fail-safe”).

Diagnostic Item	Action	Effect on Outputs	Type	Monitoring Rate	Reporting Rate
Start-up phase Diagnostics					
RAM March C-10N Test	Fail-safe mode ** ** CPU reset after 120ms	Diagnostic low/ high Reporting (optional)	Digi HW	n/applicable (start-up only)	n/applicable (start-up only)
Watchdog BIST	Fail-safe mode ** ** CPU reset after 120ms	Diagnostic low/ high Reporting (optional)	Digi HW	n/applicable (start-up only)	n/applicable (start-up only)
Under Voltage Monitoring <i>SUPPLYMONI = (MT3VB) OR (MT4VB)</i>	Start-up on Hold ** ** CPU reset after 120ms	Diagnostic low/high	Environ &Analog	n/applicable (start-up only)	n/applicable (start-up only)
Over Voltage Monitoring <i>MT7V</i>	PTC entry	Output in High-Impedance	Environ	n/applicable (start-up only)	n/applicable (start-up only)
Back-Ground Loop Diagnostics					
ROM 16bit checksum (continuous)	Fail-safe mode ** ** CPU reset after 120ms	Diagnostic low//high Reporting (optional)	Digi HW	800ms	800ms
EEPROM 8 bit CRC Check (continuous)	Fail-safe mode ** ** CPU reset after 120ms	Diagnostic low/high Reporting (optional)	Digi HW	10ms	10ms
Watchdog (continuous)	CPU reset	--	Digi HW	120ms	n/a
DSP Loop Diagnostics					
ADC Clipping <i>ADCCLIP</i>	Debouncing (programmable)	SENT Status bit0 = 1 (optional)	Environ &Analog	5/DSP	$\frac{6ms \times \text{Diag_Debounce_Thresh}}{\text{Diag_Debounce_Stepup}}$
Virtual Gain Code Out-of-spec <i>GAINOOS</i>	Debouncing (programmable)	SENT Status bit0 = 1 (optional)	Environ &Analog	1/DSP	$\frac{6ms \times \text{Diag_Debounce_Thresh}}{\text{Diag_Debounce_Stepup}}$
Virtual Gain Code Saturation [<i>GAINMIN..GAINMAX</i>]	Saturation (optional)	Gain Saturated @ <i>GAINMIN-GAINMAX</i>	Environ &Analog	n/applicable Not a diagnostic	N/A Not a diagnostic

Diagnostic Item	Action	Effect on Outputs	Type	Monitoring Rate	Reporting Rate
ADC Monitor (Analog to Digital Converter) <i>ADCMONI</i>	Debouncing (programmable)	SENT Status bit0 = 1 (optional)	Analog HW	1/DSP	$\frac{6\text{ms} \times \text{Diag_Debounce_Thresh}}{\text{Diag_Debounce_Stepup}}$
Under Voltage Monitoring <i>SUPPLYMONI = (MT3VB) OR (MT4VB)</i>	Supply Debouncing (programmable)	SENT Status bit0 = 1 (optional)	Environ &Analog	1/DSP	$\frac{6\text{ms} \times \text{Diag_Debounce_Thresh}}{\text{Diag_Debounce_Stepup}}$
Over Voltage Monitoring <i>MT7V</i>	PTC entry after PTC Debouncing	Output in High- Impedance	Environ	2ms	2ms
Temperature Sensor Monitor <i>TEMPMONI</i>	Debouncing (programmable)	SENT Status bit0 = 1 (optional)	Analog	1/DSP	$\frac{6\text{ms} \times \text{Diag_Debounce_Thresh}}{\text{Diag_Debounce_Stepup}}$
Temperature > 170 Deg.C (± 20) Temperature < - 60 Deg.C (± 20)	Saturate value used for the compensations to - 40Deg.C and +150 Deg.C resp.	No effect	Environ &Analog	N/A Not a diagnostic	N/A Not a diagnostic
Hardware Diagnostics (continuously checked by dedicated Logic)					
Read/Write Access out of physical memory	Fail-safe mode ** ** CPU reset after 120ms	Diagnostic Low/High	Digi HW	N/A Immediate Diag	N/A Immediate diagnostic
Write Access to protected area (IO and RAM Words)	Fail-safe mode ** ** CPU reset after 120ms	Diagnostic low/high	Digi HW	N/A Immediate Diag.	N/A immediate Diagnostic
Unauthorized Mode Entry	Fail-safe mode ** ** CPU reset after 120ms	Diagnostic low/high	Digi HW	N/A Immediate diagnostic	N/A Immediate diagnostic
EEPROM Error Correcting Code (Hamming correction)	(Transparent) Error Correction	No effect	Digi HW	N/A	N/A
Hardware Diagnostics (continuously checked by dedicated Analog circuits)					
Broken VSS	CPU Reset on recovery	Pull down load => Diagnostic High Pull up load => Diagnostic High	Environ	N/A Immediate diagnostic	N/A Immediate diagnostic
Broken VDD	CPU Reset on recovery	Pull down load => Diagnostic Low Pull up load => Diagnostic Low	Environ	N/A Immediate diagnostic	N/A Immediate diagnostic
Resistive Cable Test	Start-up on Hold	Diagnostic low/high	Environ	N/A Immediate diagnostic	N/A Immediate diagnostic

17. Recommended Application Diagrams

17.1. MLX90367 in SOIC-8 Package

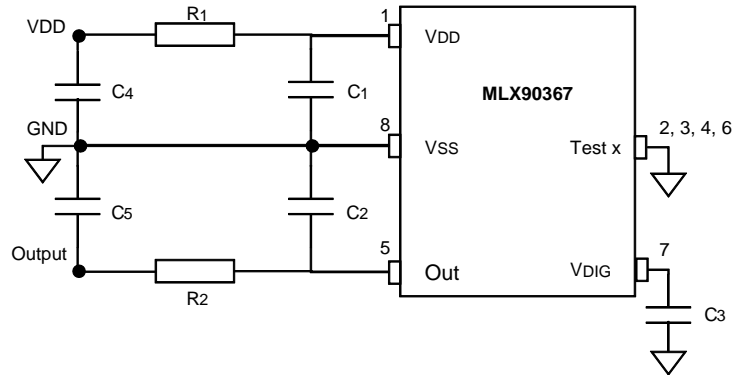

Figure 11 - Recommended wiring for the MLX90367 in SOIC-8 package

Output	Compact PCB routing			EMC robust PCB routing			Remarks	
	SENT	Min	Typ.	Max	Min	Typ.		Max
C1		100 nF	100 nF	1 uF	47 nF	100 nF	1 uF	Close to the pin
C2		2.2 nF	4.7 nF	22 nF	2.2 nF	4.7 nF	22 nF	Close to the pin
C3		47 nF	100 nF	220 nF	47 nF	100 nF	220 nF	Close to the pin
C4		-	-	-	500 pF	1 nF	10 nF	Connector Side
C5		-	-	-	500 pF	1 nF	2.2 nF	Connector Side
R1		-	-	-	0 Ω	10 Ω	33 Ω	Impacts the Voltage on VDD pin
R2		-	-	-	10 Ω	50 Ω	100 Ω	

17.2. MLX90367 in TSSOP-16 Package

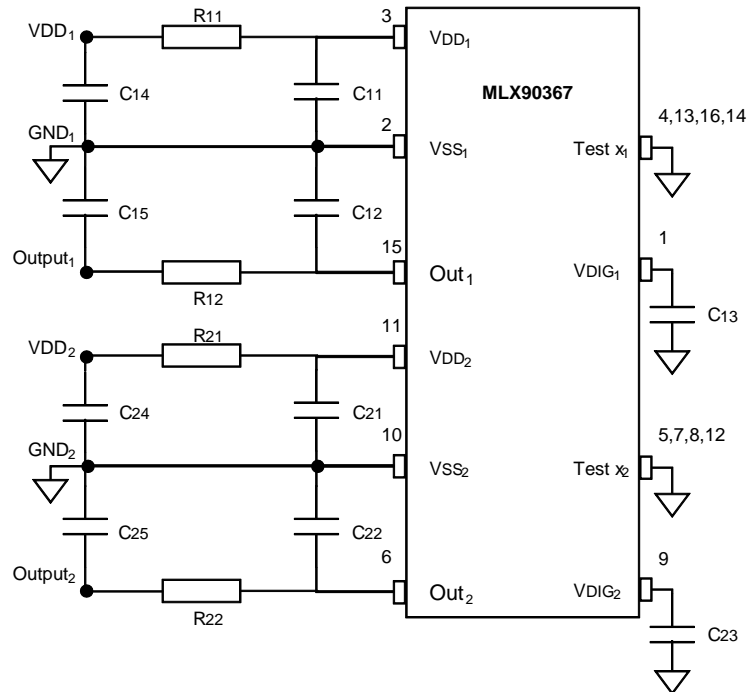

Figure 12 – Recommended wiring for the MLX90367 in TSSOP-16 package

Output SENT Output	Compact PCB routing			EMC robust PCB routing			Remarks
	Min	Typ.	Max	Min	Typ.	Max	
C11, C21	100 nF	100 nF	1 uF	47 nF	100 nF	1 uF	Close to the pin
C12, C22	2.2 nF	4.7 nF	22 nF	2.2 nF	4.7 nF	22 nF	Close to the pin
C13, C23	47 nF	100 nF	220 nF	47 nF	100 nF	220 nF	Close to the pin
C14, C24	-	-	-	500 pF	1 nF	10 nF	Connector Side
C15, C25	-	-	-	500 pF	1 nF	2.2 nF	Connector Side
R11, R21	-	-	-	0 Ω	10 Ω	33 Ω	Impacts the Voltage on VDD pin
R12, R22	-	-	-	10 Ω	50 Ω	100 Ω	

18. Standard information regarding manufacturability of Melexis products with different soldering processes

Our products are classified and qualified regarding soldering technology, solderability and moisture sensitivity level according to standards in place in Semiconductor industry.

For further details about test method references and for compliance verification of selected soldering method for product integration, Melexis recommends reviewing on our web site the General Guidelines soldering recommendation (<http://www.melexis.com/en/quality-environment/soldering>).

For all soldering technologies deviating from the one mentioned in above document (regarding peak temperature, temperature gradient, temperature profile etc), additional classification and qualification tests have to be agreed upon with Melexis.

For package technology embedding trim and form post-delivery capability, Melexis recommends consulting the dedicated trim&forming recommendation application note: lead trimming and forming recommendations (<http://www.melexis.com/en/documents/documentation/application-notes/lead-trimming-and-forming-recommendations>).

Melexis is contributing to global environmental conservation by promoting lead free solutions. For more information on qualifications of RoHS compliant products (RoHS = European directive on the Restriction Of the use of certain Hazardous Substances) please visit the quality page on our website: <http://www.melexis.com/en/quality-environment>.

19. ESD Precautions

Electronic semiconductor products are sensitive to Electro Static Discharge (ESD).

Always observe Electro Static Discharge control procedures whenever handling semiconductor products.

20. Package Information

20.1. SOIC-8 - Package Dimensions

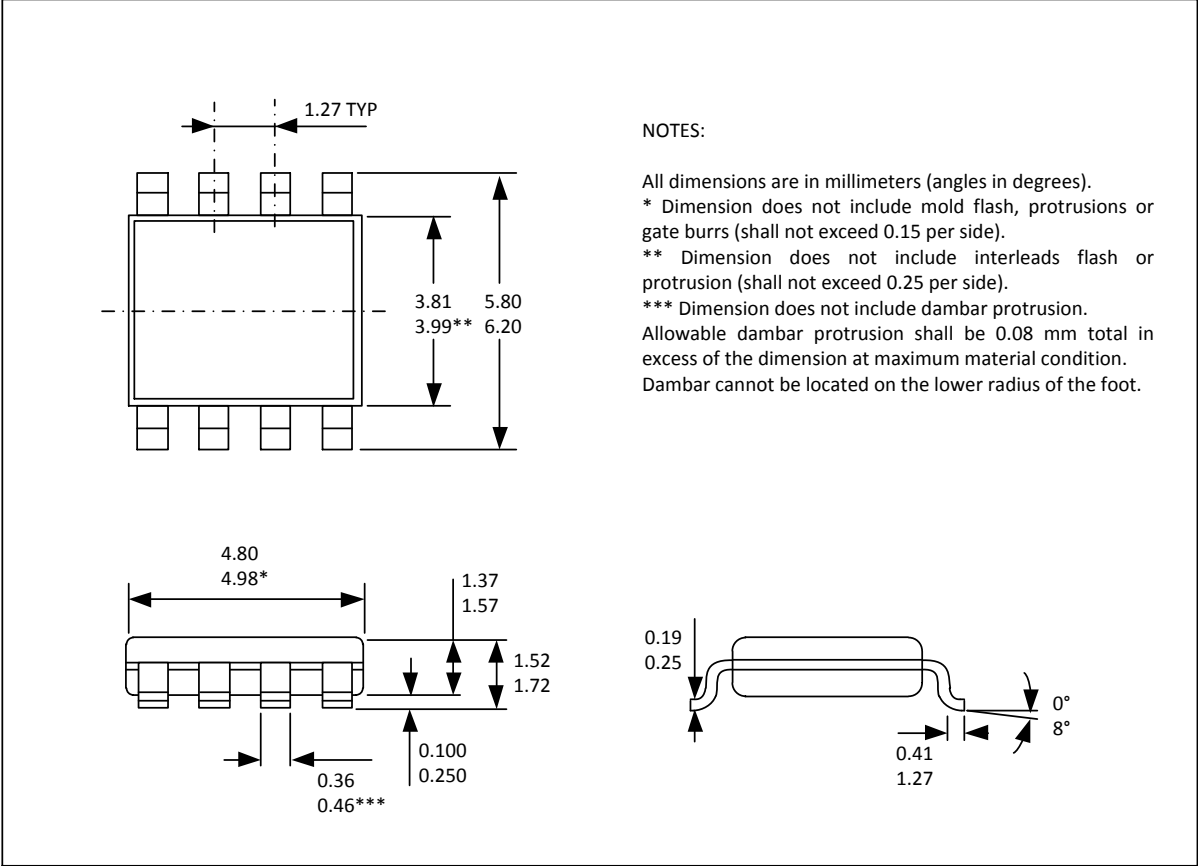

20.2. SOIC-8 - Pinout and Marking

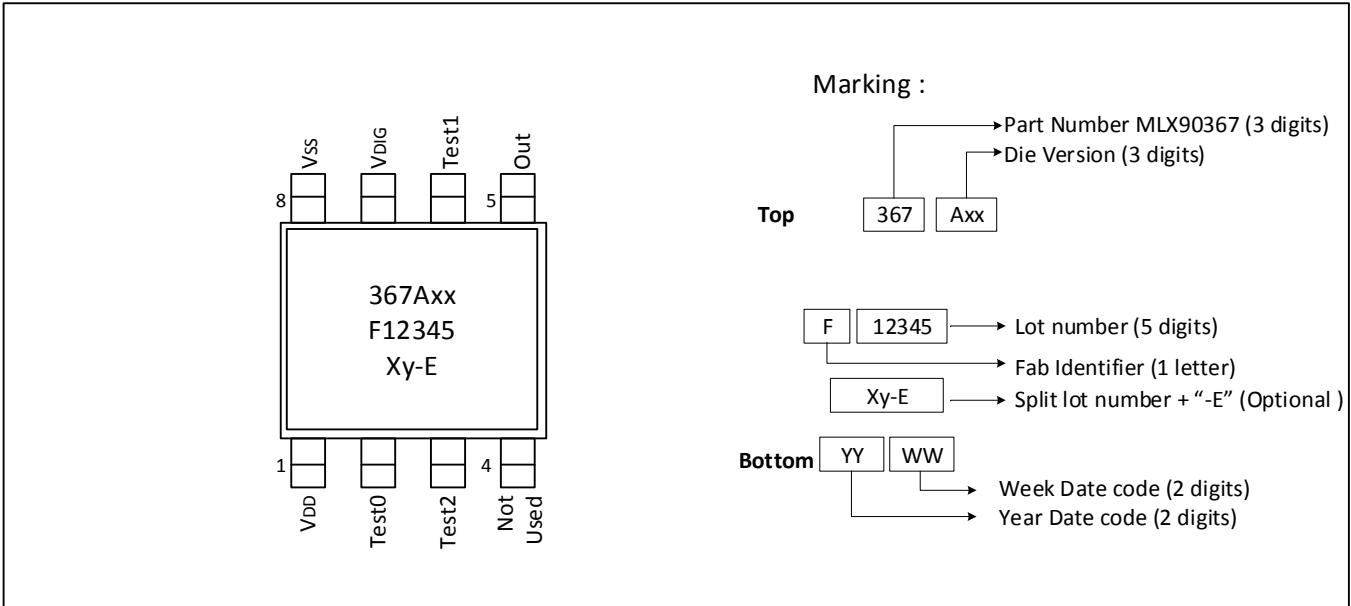

20.3. SOIC-8 - Sensitive spot positioning

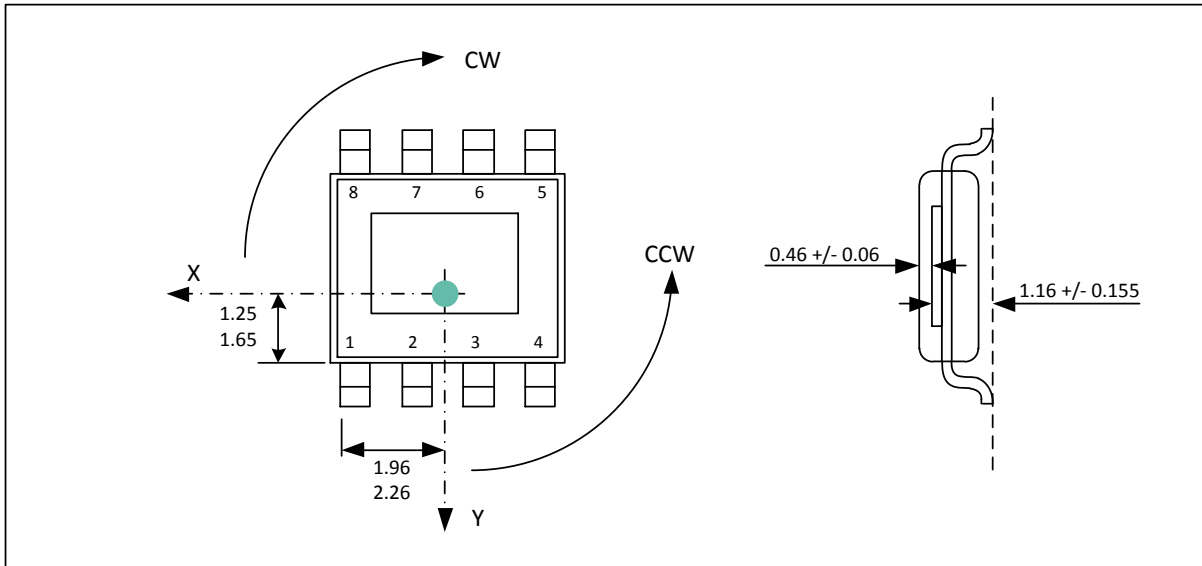

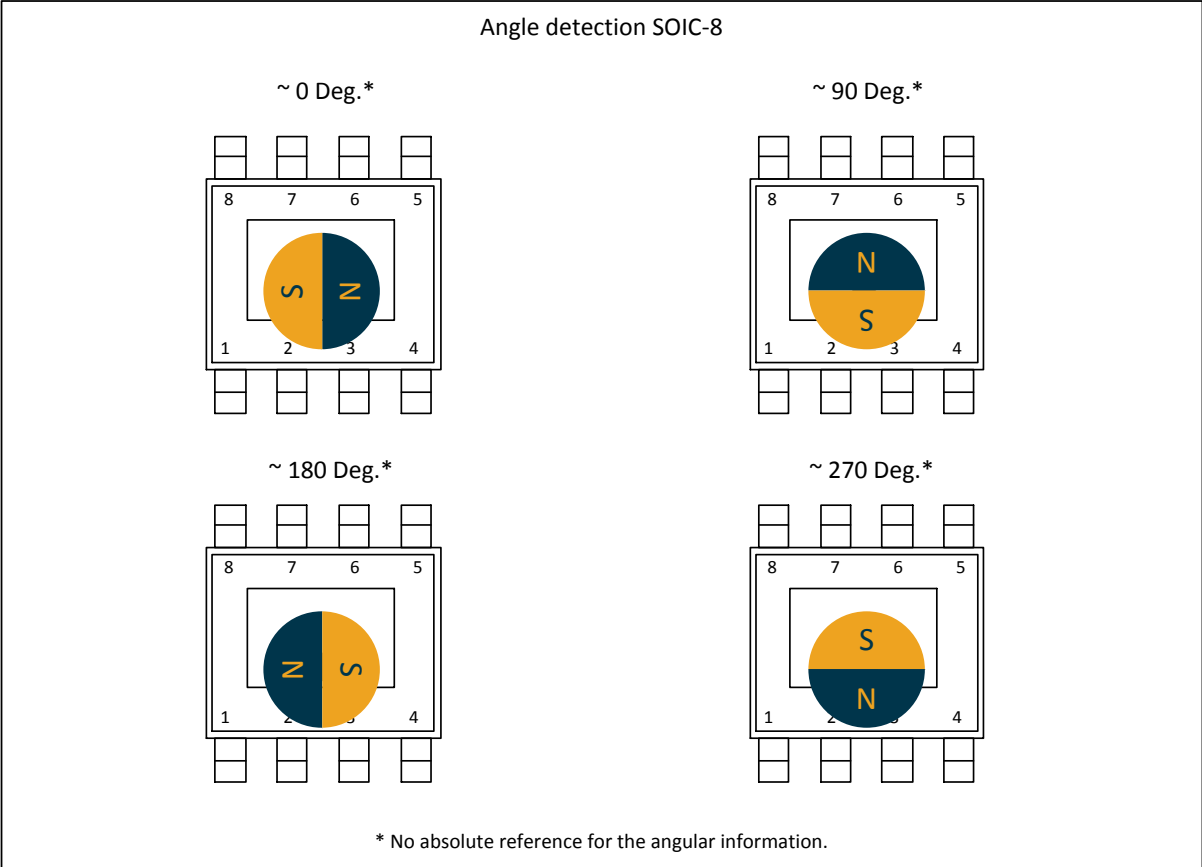

The MLX90367 is an absolute angular position sensor but the linearity error (Le – See section 9) does not include the error linked to the absolute reference 0 Deg.

20.4. TSSOP-16 - Package Dimensions

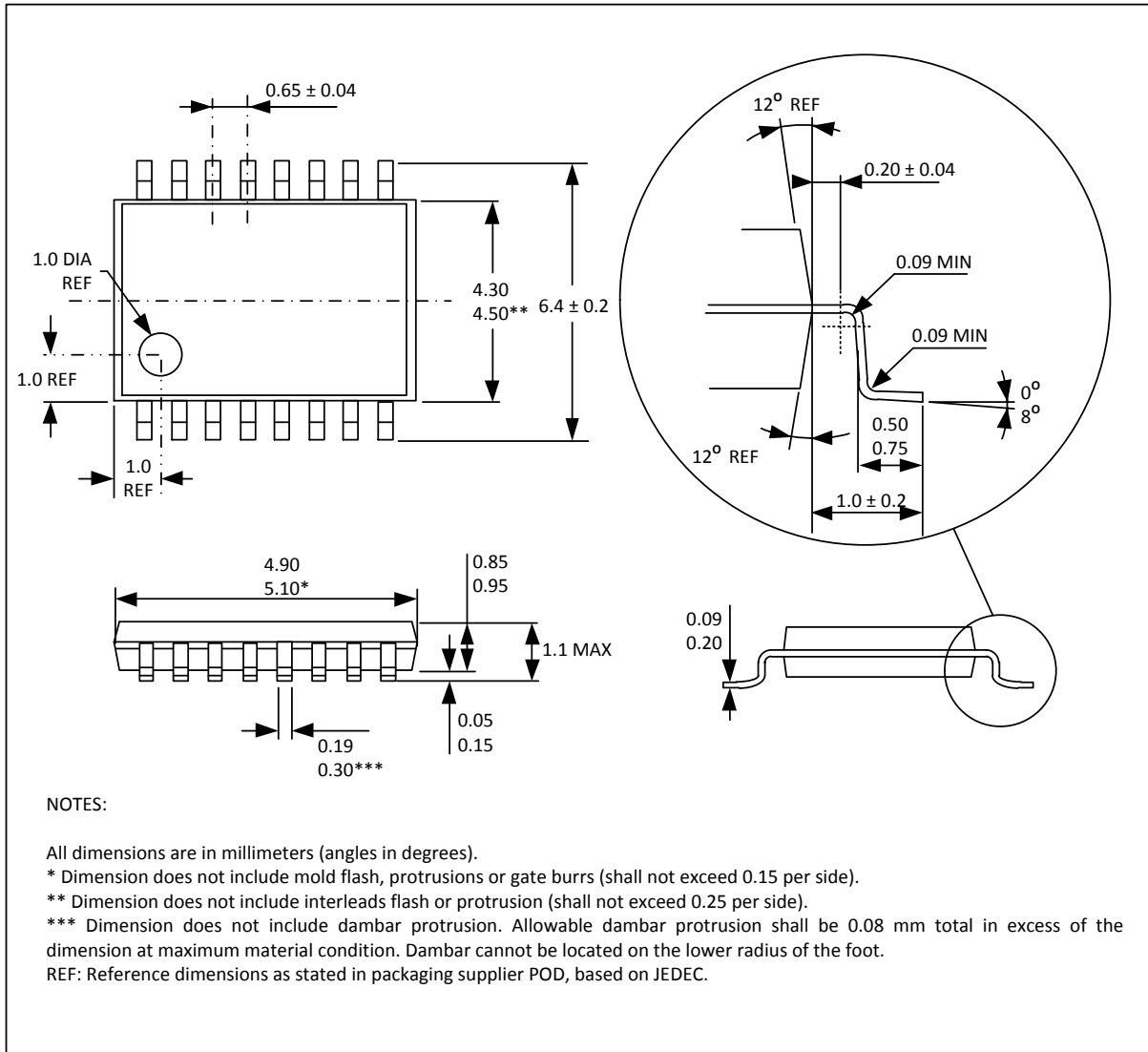

20.5. TSSOP-16 - Pinout and Marking

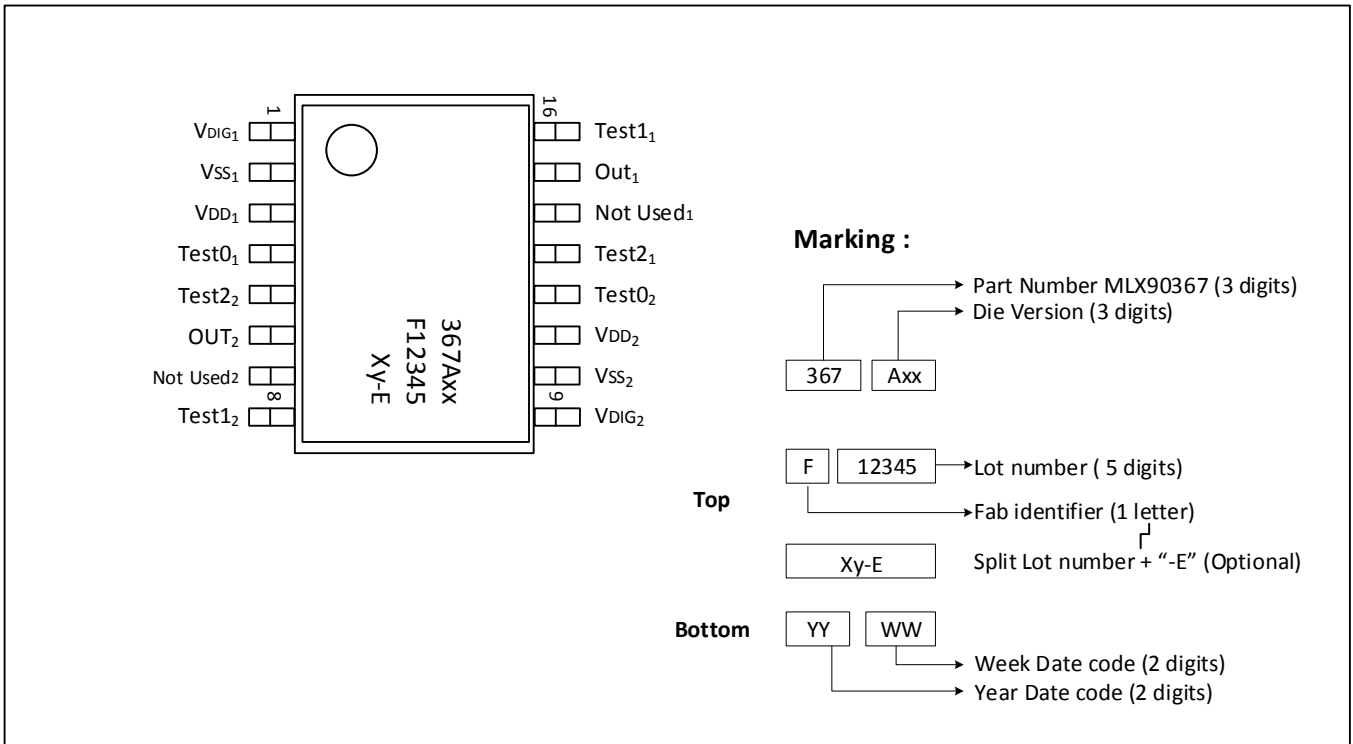

20.6. TSSOP-16 - Sensitive spot positioning

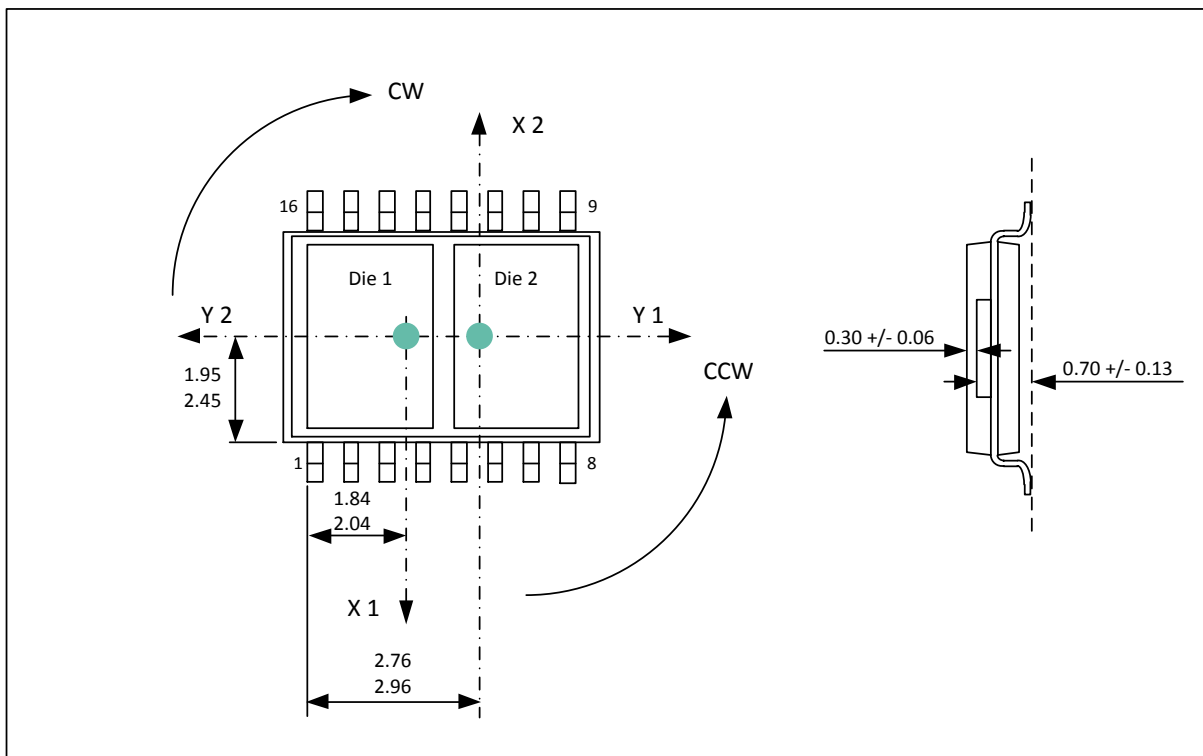

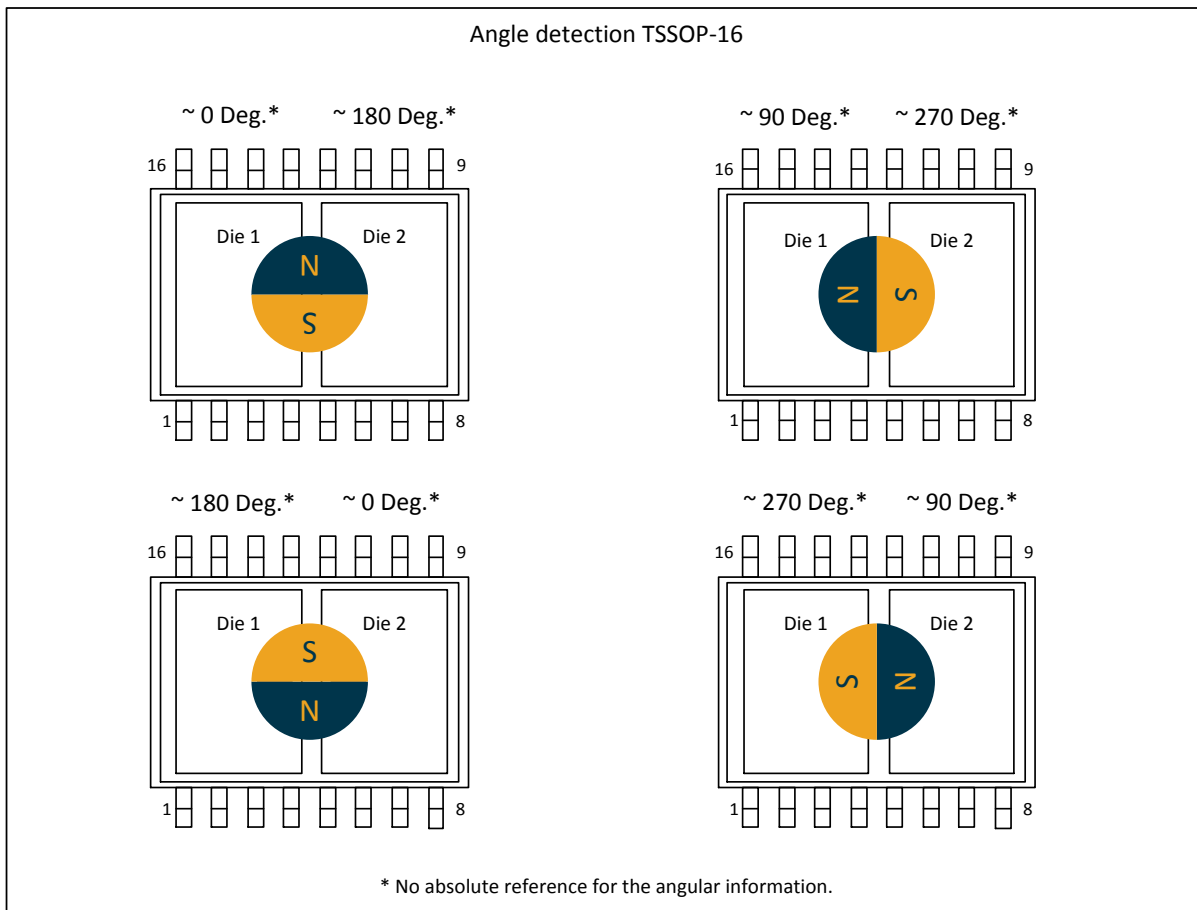

The MLX90367 is an absolute angular position sensor but the linearity error (Le – See section 9) does not include the error linked to the absolute reference 0 Deg.

21. Disclaimer

The information furnished by Melexis herein ("Information") is believed to be correct and accurate. Melexis disclaims (i) any and all liability in connection with or arising out of the furnishing, performance or use of the technical data or use of the product(s) as described herein ("Product") (ii) any and all liability, including without limitation, special, consequential or incidental damages, and (iii) any and all warranties, express, statutory, implied, or by description, including warranties of fitness for particular purpose, non-infringement and merchantability. No obligation or liability shall arise or flow out of Melexis' rendering of technical or other services.

The Information is provided "as is" and Melexis reserves the right to change the Information at any time and without notice. Therefore, before placing orders and/or prior to designing the Product into a system, users or any third party should obtain the latest version of the relevant information to verify that the information being relied upon is current.

Users or any third party must further determine the suitability of the Product for its application, including the level of reliability required and determine whether it is fit for a particular purpose.

The Information is proprietary and/or confidential information of Melexis and the use thereof or anything described by the Information does not grant, explicitly or implicitly, to any party any patent rights, licenses, or any other intellectual property rights.

This document as well as the Product(s) may be subject to export control regulations. Please be aware that export might require a prior authorization from competent authorities.

The Product(s) are intended for use in normal commercial applications. Unless otherwise agreed upon in writing, the Product(s) are not designed, authorized or warranted to be suitable in applications requiring extended temperature range and/or unusual environmental requirements. High reliability applications, such as medical life-support or life-sustaining equipment are specifically not recommended by Melexis.

The Product(s) may not be used for the following applications subject to export control regulations: the development, production, processing, operation, maintenance, storage, recognition or proliferation of 1) chemical, biological or nuclear weapons, or for the development, production, maintenance or storage of missiles for such weapons; 2) civil firearms, including spare parts or ammunition for such arms; 3) defense related products, or other material for military use or for law enforcement; 4) any applications that, alone or in combination with other goods, substances or organisms could cause serious harm to persons or goods and that can be used as a means of violence in an armed conflict or any similar violent situation.

The Products sold by Melexis are subject to the terms and conditions as specified in the Terms of Sale, which can be found at <https://www.melexis.com/en/legal/terms-and-conditions>.

This document supersedes and replaces all prior information regarding the Product(s) and/or previous versions of this document.

Melexis NV © - No part of this document may be reproduced without the prior written consent of Melexis. (2019)

ISO/TS 16949 and ISO14001 Certified

22. Contact

For the latest version of this document, go to our website at www.melexis.com. For additional information, please contact our Direct Sales team and get help for your specific needs:

Europe, Africa	Telephone: +32 13 67 04 95 Email : sales_europe@melexis.com
Americas	Telephone: +1 603 223 2362 Email : sales_usa@melexis.com
Asia	Email : sales_asia@melexis.com

Looking for pricing, stock, or lifecycle information?

Click below to explore more details on WIN SOURCE:

- [View MLX90367LDC-ABV-000-RE on WIN SOURCE](#)
- [Melexis Technologies NV Information](#)

Optimize Your Supply Chain with WIN SOURCE Solutions

- ✓ Global Sourcing Solution
- ✓ Obsolete Management
- ✓ Cost Control Management
- ✓ Shortage Management
- ✓ Alternative Solution
- ✓ Excess Inventory Management