



**THE DATASHEET OF  
74LVC1G17Z-7**



## Description

The 74LVC1G17 is a single 1-input Schmitt-trigger buffer with a standard push-pull output. The device is designed for operation with a power supply range of 1.65V to 5.5V. The inputs are tolerant to 5.5V allowing this device to be used in a mixed voltage environment. The device is fully specified for partial power down applications using I<sub>OFF</sub>. The I<sub>OFF</sub> circuitry disables the output preventing damaging current backflow when the device is powered down. The gate performs the positive Boolean function:

$$Y = A$$

## Pin Assignments

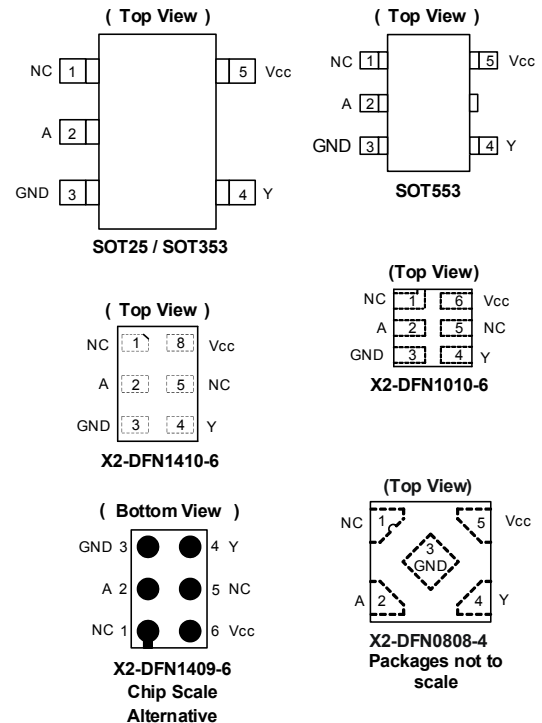

## Features

- Wide Supply Voltage Range from 1.65V to 5.5V
- ±24mA Output Drive at 3.3V
- CMOS Low Power Consumption
- I<sub>OFF</sub> Supports Partial-Power-Down Mode Operation
- Inputs Accept up to 5.5V
- ESD Protection Tested per JESD 22
  - Exceeds 2000-V Human Body Model (A114)
  - Exceeds 1000-V Charged Device Model (C101)
- Latch-Up Exceeds 100mA per JESD 78, Class I
- Range of Package Options
- **Totally Lead-Free & Fully RoHS Compliant (Notes 1 & 2)**
- **Halogen and Antimony Free. "Green" Device (Note 3)**
- **For automotive applications requiring specific change control (i.e. parts qualified to AEC-Q100/101/200, PPAP capable, and manufactured in IATF 16949 certified facilities), please [contact us](#) or your local Diodes representative.**  
<https://www.diodes.com/quality/product-definitions/>
- **An Automotive-Compliant Part is Available Under Separate Datasheet ([74LVC1G17Q](#))**

## Applications

- Voltage Level Shifting
- General Purpose Logic
- Power Down Signal Isolation
- Wide Array of Products such as:
  - PCs, Networking, Notebooks, Netbooks,
  - Computer Peripherals, Hard Drives, CD/DVD ROM
  - TV, DVD, DVR, Set Top Box
  - Cell Phones, Personal Navigation / GPS
  - MP3 Players, Cameras, Video Recorders

Notes: 1. No purposely added lead. Fully EU Directive 2002/95/EC (RoHS), 2011/65/EU (RoHS 2) & 2015/863/EU (RoHS 3) compliant.  
2. See <https://www.diodes.com/quality/lead-free/> for more information about Diodes Incorporated's definitions of Halogen- and Antimony-free, "Green" and Lead-free.  
3. Halogen- and Antimony-free "Green" products are defined as those which contain <900ppm bromine, <900ppm chlorine (<1500ppm total Br + Cl) and <1000ppm antimony compounds.

### Pin Descriptions

Pin Name	Description
A	Data Input
GND	Ground
Y	Data Output
V <sub>CC</sub>	Supply Voltage

### Logic Diagram

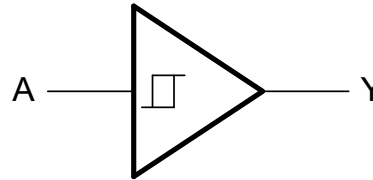

### Function Table

Input	Output
A	Y
H	H
L	L

### Absolute Maximum Ratings (Notes 4 & 5)

Symbol	Description	Rating	Unit
ESD HBM	Human Body Model ESD Protection	2	kV
ESD CDM	Charged Device Model ESD Protection	1	kV
V <sub>CC</sub>	Supply Voltage Range	-0.5 to 6.5	V
V <sub>I</sub>	Input Voltage Range	-0.5 to 6.5	V
V <sub>O</sub>	Voltage Applied to Output in High Impedance or I <sub>OFF</sub> State	-0.5 to 6.5	V
V <sub>O</sub>	Voltage Applied to Output in High or Low State	-0.5 to V <sub>CC</sub> + 0.5	V
I <sub>IK</sub>	Input Clamp Current V <sub>I</sub> < 0	-50	mA
I <sub>OK</sub>	Output Clamp Current	-50	mA
I <sub>O</sub>	Continuous Output Current	±50	mA
I <sub>CC</sub> , I <sub>GND</sub>	Continuous Current through V <sub>CC</sub> or GND	±100	mA
T <sub>J</sub>	Operating Junction Temperature	-40 to +150	°C
T <sub>STG</sub>	Storage Temperature	-65 to +150	°C

- Notes:
- Stresses beyond the absolute maximum can result in immediate failure or reduced reliability. These are stress values and device operation should be within recommend values.
  - Forcing the maximum allowed voltage could cause a condition exceeding the maximum current or conversely forcing the maximum current could cause a condition exceeding the maximum voltage. The ratings of both current and voltage must be maintained within the controlled range.

### Recommended Operating Conditions (Note 6)

Symbol	Parameter		Min	Max	Unit
V <sub>CC</sub>	Operating Voltage	Operating	1.65	5.5	V
		Data retention only	1.5	—	V
V <sub>I</sub>	Input Voltage		0	5.5	V
V <sub>O</sub>	Output Voltage		0	V <sub>CC</sub>	V
I <sub>OH</sub>	High-Level Output current	V <sub>CC</sub> = 1.65V	—	-4	mA
		V <sub>CC</sub> = 2.3V	—	-8	
		V <sub>CC</sub> = 2.7V	—	-12	
		V <sub>CC</sub> = 3V	—	-16	
		V <sub>CC</sub> = 4.5V	—	-24	
I <sub>OL</sub>	Low-Level Output current	V <sub>CC</sub> = 1.65V	—	4	mA
		V <sub>CC</sub> = 2.3V	—	8	
		V <sub>CC</sub> = 2.7V	—	12	
		V <sub>CC</sub> = 3V	—	16	
		V <sub>CC</sub> = 4.5V	—	24	
T <sub>A</sub>	Operating Free-Air Temperature	—	-40	+125	°C

Note: 6. Unused inputs should be held at V<sub>CC</sub> or Ground.

**Electrical Characteristics** (@  $T_A = -40^{\circ}\text{C}$  to  $+85^{\circ}\text{C}$ . All typical values are at  $V_{CC} = 3.3\text{V}$ ,  $T_A = +25^{\circ}\text{C}$ .)

Symbol	Parameter	Test Conditions	$V_{CC}$	Min	Typ	Max	Unit
$V_{T+}$	Positive-Going Input Threshold Voltage	—	1.65V	0.70	—	1.20	—
		—	2.3V	1.11	—	1.60	—
		—	3V	1.50	—	2.00	—
		—	4.5V	2.16	—	2.74	—
		—	5.5V	2.61	—	3.33	—
$V_{T-}$	Negative-Going Input Threshold Voltage	—	1.65V	0.30	—	0.72	—
		—	2.3V	0.58	—	1.00	—
		—	3V	0.80	—	1.30	—
		—	4.5V	1.21	—	1.95	—
		—	5.5V	1.45	—	2.35	—
$\Delta V_T$	Hysteresis ( $V_{T+} - V_{T-}$ )	—	1.65V	0.30	—	0.62	—
		—	2.3V	0.40	—	0.80	—
		—	3V	0.35	—	1.00	—
		—	4.5V	0.55	—	1.10	—
		—	5.5V	0.60	—	1.20	—
$V_{OH}$	High Level Output Voltage	$I_{OH} = -100\mu\text{A}$	1.65V to 5.5V	$V_{CC} - 0.1$	—	—	V
		$I_{OH} = -4\text{mA}$	1.65V	1.2	—	—	
		$I_{OH} = -8\text{mA}$	2.3V	1.9	—	—	
		$I_{OH} = -12\text{mA}$	2.7V	2.2	—	—	
		$I_{OH} = -16\text{mA}$	3V	2.4	—	—	
		$I_{OH} = -24\text{mA}$		2.3	—	—	
		$I_{OH} = -32\text{mA}$	4.5V	3.8	—	—	
$V_{OL}$	Low-Level Output Voltage	$I_{OL} = 100\mu\text{A}$	1.65V to 5.5V	—	—	0.1	V
		$I_{OL} = 4\text{mA}$	1.65V	—	—	0.45	
		$I_{OL} = 8\text{mA}$	2.3V	—	—	0.3	
		$I_{OL} = 12\text{mA}$	2.7V	—	—	0.4	
		$I_{OL} = 16\text{mA}$	3V	—	—	0.4	
		$I_{OL} = 24\text{mA}$		—	—	0.55	
		$I_{OL} = 32\text{mA}$	4.5V	—	—	0.55	
$I_i$	Input Current	$V_i = 5.5\text{V}$ or GND	0 to 5.5V	—	—	$\pm 5$	$\mu\text{A}$
$I_{OFF}$	Power Down Leakage Current	$V_i$ or $V_o = 5.5\text{V}$	0	—	—	$\pm 10$	$\mu\text{A}$
$I_{CC}$	Supply Current	$V_i = 5.5\text{V}$ of GND $I_o = 0$	1.65V to 5.5V	—	—	10	$\mu\text{A}$
$\Delta I_{CC}$	Additional Supply Current	Input at $V_{CC} - 0.6\text{V}$	3V to 5.5V	—	—	500	$\mu\text{A}$

**Electrical Characteristics** (continued) (@  $T_A = -40^\circ\text{C}$  to  $+125^\circ\text{C}$ . All typical values are at  $V_{CC} = 3.3\text{V}$ ,  $T_A = +25^\circ\text{C}$ .)

Symbol	Parameter	Test Conditions	V <sub>CC</sub>	Min	Typ	Max	Unit
V <sub>T+</sub>	Positive-Going Input Threshold Voltage	—	1.65V	0.70	—	1.20	—
		—	2.3V	1.11	—	1.60	—
		—	3V	1.50	—	2.00	—
		—	4.5V	2.16	—	2.74	—
		—	5.5V	2.61	—	3.33	—
V <sub>T-</sub>	Negative-Going Input Threshold Voltage	—	1.65V	0.30	—	0.75	—
		—	2.3V	0.58	—	1.03	—
		—	3V	0.80	—	1.33	—
		—	4.5V	1.21	—	1.95	—
		—	5.5V	1.45	—	2.35	—
ΔV <sub>T</sub>	Hysteresis (V <sub>T+</sub> - V <sub>T-</sub> )	—	1.65V	0.30	—	0.62	—
		—	2.3V	0.37	—	0.80	—
		—	3V	0.32	—	1.00	—
		—	4.5V	0.50	—	1.20	—
		—	5.5V	0.55	—	1.40	—
V <sub>OH</sub>	High Level Output Voltage	I <sub>OH</sub> = -100μA	1.65V to 5.5V	V <sub>CC</sub> - 0.1	—	—	V
		I <sub>OH</sub> = -4mA	1.65V	0.95	—	—	
		I <sub>OH</sub> = -8mA	2.3V	1.7	—	—	
		I <sub>OH</sub> = -12mA	2.7V	1.9	—	—	
		I <sub>OH</sub> = -16mA	3V	2.2	—	—	
		I <sub>OH</sub> = -24mA		2.0	—	—	
		I <sub>OH</sub> = -32mA	4.5V	3.4	—	—	
V <sub>OL</sub>	Low-Level Output Voltage	I <sub>OL</sub> = 100μA	1.65V to 5.5V	—	—	0.1	V
		I <sub>OL</sub> = 4mA	1.65V	—	—	0.7	
		I <sub>OL</sub> = 8mA	2.3V	—	—	0.45	
		I <sub>OL</sub> = 12mA	2.7V	—	—	0.6	
		I <sub>OL</sub> = 16mA	3V	—	—	0.6	
		I <sub>OL</sub> = 24mA		—	—	0.8	
		I <sub>OL</sub> = 32mA	4.5V	—	—	0.8	
I <sub>I</sub>	Input Current	V <sub>I</sub> = 5.5V or GND	0 to 5.5V	—	—	±5	μA
I <sub>OFF</sub>	Power Down Leakage Current	V <sub>I</sub> or V <sub>O</sub> = 5.5V	0	—	—	±10	μA
I <sub>CC</sub>	Supply Current	V <sub>I</sub> = 5.5V of GND I <sub>O</sub> = 0	1.65V to 5.5V	—	—	10	μA
ΔI <sub>CC</sub>	Additional Supply Current	Input at V <sub>CC</sub> - 0.6V	3V to 5.5V	—	—	500	μA

**Package Characteristics** (All typical values are at  $V_{CC} = 3.3V$ ,  $T_A = +25^{\circ}C$ .)

Symbol	Parameter	Test Conditions	$V_{CC}$	Min	Typ	Max	Unit
$\theta_{JA}$	Thermal Resistance Junction-to-Ambient	SOT25	(Note 7)	—	204	—	$^{\circ}C/W$
		SOT353		—	371	—	
		SOT553		—	231	—	
		X2-DFN0808-4		—	400	—	
		X2-DFN1010-6		—	445	—	
		X2-DFN1409-6		—	470	—	
		X2-DFN1410-6		—	460	—	
$\theta_{JC}$	Thermal Resistance Junction-to-Case	SOT25	(Note 7)	—	52	—	$^{\circ}C/W$
		SOT353		—	143	—	
		SOT553		—	105	—	
		X2-DFN0808-4		—	225	—	
		X2-DFN1010-6		—	250	—	
		X2-DFN1409-6		—	275	—	
		X2-DFN1410-6		—	265	—	

Note: 7. Test condition for each of the 7 package types: Device mounted on FR-4 substrate PC board, 2oz copper, with minimum recommended pad layout.

**Switching Characteristics**

$T_A = -40^{\circ}C$  to  $+85^{\circ}C$ ,  $C_L = 15pF$  as noted (See Figure 1)

Parameter	From Input	To Output	$V_{CC} = 1.8V \pm 0.15V$		$V_{CC} = 2.5V \pm 0.2V$		$V_{CC} = 3.3V \pm 0.3V$		$V_{CC} = 5V \pm 0.5V$		Unit
			Min	Max	Min	Max	Min	Max	Min	Max	
$t_{PD}$	A	Y	1.0	9.9	0.7	5.5	0.7	4.6	0.7	4.4	ns

$T_A = -40^{\circ}C$  to  $+85^{\circ}C$ ,  $C_L = 30pF$  or  $50pF$  as noted (See Figure 2)

Parameter	From Input	To Output	$V_{CC} = 1.8V \pm 0.15V$		$V_{CC} = 2.5V \pm 0.2V$		$V_{CC} = 3.3V \pm 0.3V$		$V_{CC} = 5V \pm 0.5V$		Unit
			Min	Max	Min	Max	Min	Max	Min	Max	
$t_{PD}$	A	Y	1.0	11	0.7	6.5	0.7	5.5	0.7	5	ns

$T_A = -40^{\circ}C$  to  $+125^{\circ}C$ ,  $C_L = 15pF$  as noted (See Figure 1)

Parameter	From Input	To Output	$V_{CC} = 1.8V \pm 0.15V$		$V_{CC} = 2.5V \pm 0.2V$		$V_{CC} = 3.3V \pm 0.3V$		$V_{CC} = 5V \pm 0.5V$		Unit
			Min	Max	Min	Max	Min	Max	Min	Max	
$t_{PD}$	A	Y	1.0	12.5	0.7	7.5	0.7	6.5	0.7	5.5	ns

$T_A = -40^{\circ}C$  to  $+125^{\circ}C$ ,  $C_L = 30pF$  or  $50pF$  as noted (See Figure 2)

Parameter	From Input	To Output	$V_{CC} = 1.8V \pm 0.15V$		$V_{CC} = 2.5V \pm 0.2V$		$V_{CC} = 3.3V \pm 0.3V$		$V_{CC} = 5V \pm 0.5V$		Unit
			Min	Max	Min	Max	Min	Max	Min	Max	
$t_{PD}$	A	Y	1.0	14.0	0.7	8.5	0.7	7.0	0.7	6.5	ns

**Operating Characteristics**

T<sub>A</sub> = +25°C

Parameter		Test Conditions	V <sub>CC</sub> = 1.8V	V <sub>CC</sub> = 2.5V	V <sub>CC</sub> = 3.3V	V <sub>CC</sub> = 5V	Unit
			Typ	Typ	Typ	Typ	
C <sub>PD</sub>	Power Dissipation Capacitance	f = 10MHz	20	22	23	25	pF

**Parameter Measurement Information**

From Output Under Test

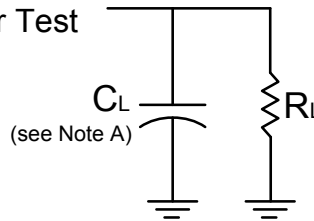

V <sub>CC</sub>	Inputs		V <sub>M</sub>	C <sub>L</sub>	R <sub>L</sub>
	V <sub>I</sub>	t <sub>R</sub> /t <sub>F</sub>			
1.8V±0.15V	V <sub>CC</sub>	≤2ns	V <sub>CC</sub> /2	15pF	1MΩ
2.5V±0.2V	V <sub>CC</sub>	≤2ns	V <sub>CC</sub> /2	15pF	1MΩ
3.3V±0.3V	3V	≤2.5ns	1.5V	15pF	1MΩ
5V±0.5V	V <sub>CC</sub>	≤2.5ns	V <sub>CC</sub> /2	15pF	1MΩ

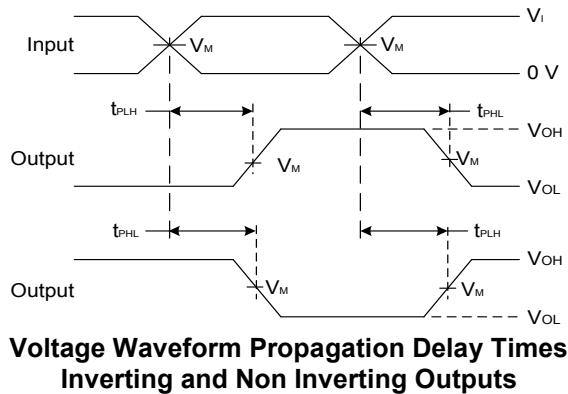
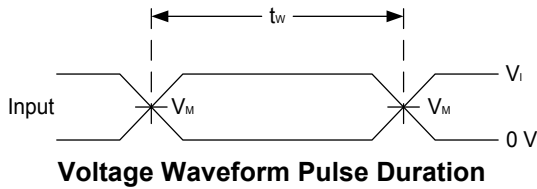
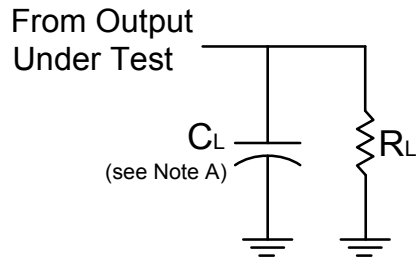

Figure 1. Load Circuit and Voltage Waveforms

- Notes:
- A. Includes test lead and test apparatus capacitance.
  - B. All pulses are supplied at pulse repetition rate ≤ 10MHz.
  - C. Inputs are measured separately one transition per measurement.
  - D. t<sub>PLH</sub> and t<sub>PHL</sub> are the same as t<sub>PD</sub>.

**Parameter Measurement Information** (continued)



V <sub>CC</sub>	Inputs		V <sub>M</sub>	C <sub>L</sub>	R <sub>L</sub>
	V <sub>I</sub>	t <sub>R</sub> /t <sub>F</sub>			
1.8V±0.15V	V <sub>CC</sub>	≤2ns	V <sub>CC</sub> /2	30pF	1kΩ
2.5V±0.2V	V <sub>CC</sub>	≤2ns	V <sub>CC</sub> /2	30pF	500Ω
3.3V±0.3V	3V	≤2.5ns	1.5V	50pF	500Ω
5V±0.5V	V <sub>CC</sub>	≤2.5ns	V <sub>CC</sub> /2	50pF	500Ω

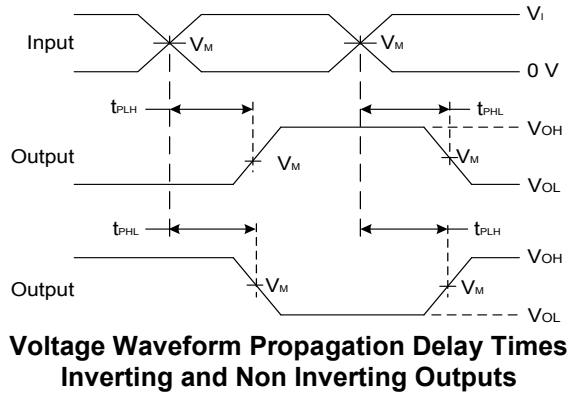
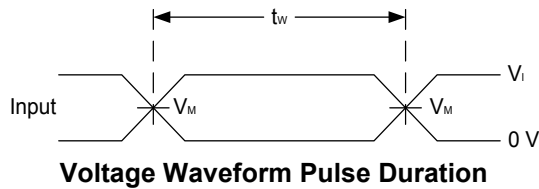

**Figure 2. Load Circuit and Voltage Waveforms**

- Notes:
- A. Includes test lead and test apparatus capacitance.
  - B. All pulses are supplied at pulse repetition rate ≤ 10MHz.
  - C. Inputs are measured separately one transition per measurement.
  - D. t<sub>PLH</sub> and t<sub>PHL</sub> are the same as t<sub>PD</sub>.

**Ordering Information** (Note 8)

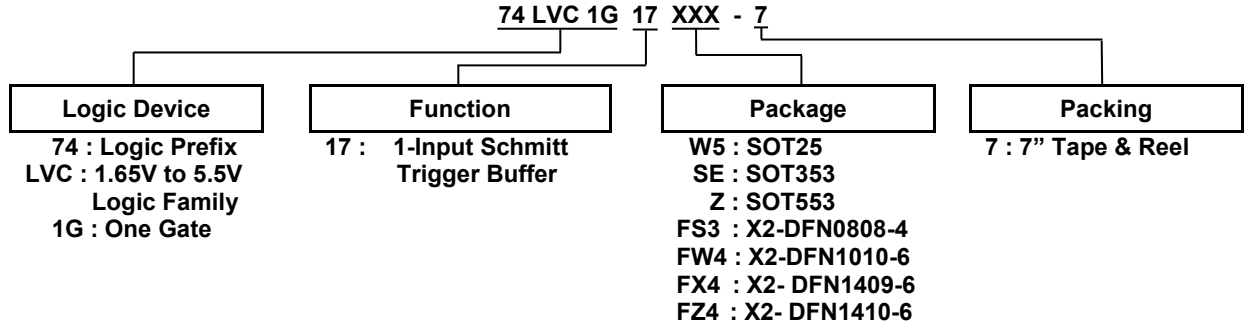

Device	Package Code	Package (Notes 9, 10)	7" Tape and Reel	
			Quantity	Part Number Suffix
74LVC1G17W5-7	W5	SOT25	3,000/Tape & Reel	-7
74LVC1G17SE-7	SE	SOT353	3,000/Tape & Reel	-7
74LVC1G17Z-7	Z	SOT553	4,000/Tape & Reel	-7
74LVC1G17FS3-7	FS3	X2-DFN0808-4	5,000/Tape & Reel	-7
74LVC1G17FW4-7	FW4	X2-DFN1010-6	5,000/Tape & Reel	-7
74LVC1G17FX4-7	FX4	X2-DFN1409-6 <b>(Chip Scale Alternative)</b>	5,000/Tape & Reel	-7
74LVC1G17FZ4-7	FZ4	X2-DFN1410-6	5,000/Tape & Reel	-7

Notes: 8. For packaging details, go to our website at <https://www.diodes.com/design/support/packaging/diodes-packaging/>.  
 9. Pad layout as shown in Diodes Incorporated's package outline PDFs, which can be found on our website at <http://www.diodes.com/package-outlines.html>.  
 10. The taping orientation is located on our website at <https://www.diodes.com/assets/Packaging-Support-Docs/ap02007.pdf>.

## Marking Information

(1) SOT25, SOT353 and SOT553

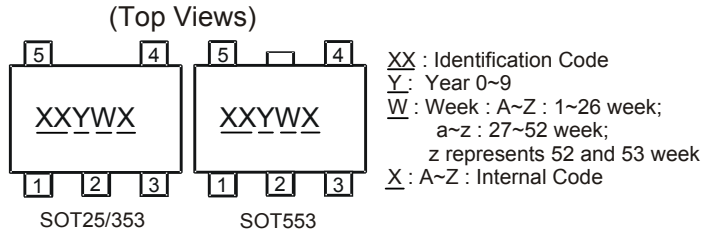

Part Number	Package	Identification Code
74LVC1G17W5-7	SOT25	UR
74LVC1G17SE-7	SOT353	UR
74LVC1G17Z-7	SOT553	UR

(2) DFN Packages

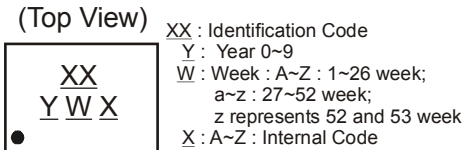

Part Number	Package	Identification Code
74LVC1G17FS3-7	X2-DFN0808-4	WR
74LVC1G17FW4-7	X2-DFN1010-6	UR
74LVC1G17FX4-7	X2-DFN1409-6	MH
74LVC1G17FZ4-7	X2-DFN1410-6	UR

**Package Outline Dimensions**

Please see <http://www.diodes.com/package-outlines.html> for the latest version.

**(1) Package Type: SOT25**

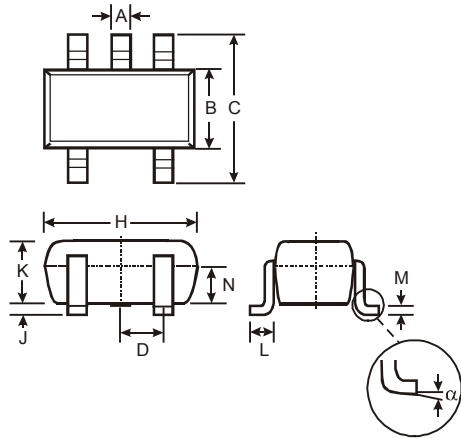

SOT25			
Dim	Min	Max	Typ
A	0.35	0.50	0.38
B	1.50	1.70	1.60
C	2.70	3.00	2.80
D	-	-	0.95
H	2.90	3.10	3.00
J	0.013	0.10	0.05
K	1.00	1.30	1.10
L	0.35	0.55	0.40
M	0.10	0.20	0.15
N	0.70	0.80	0.75
α	0°	8°	-
All Dimensions in mm			

**(2) Package Type: SOT353**

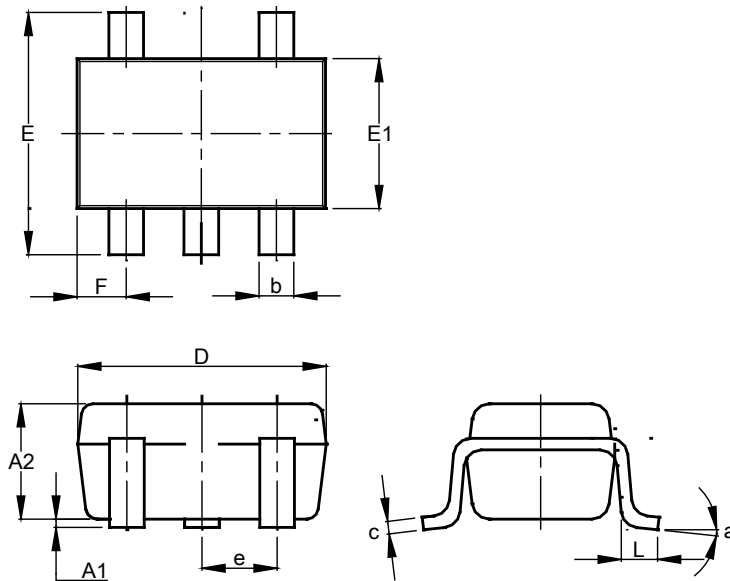

SOT353			
Dim	Min	Max	Typ
A1	0.00	0.10	0.05
A2	0.90	1.00	0.95
b	0.10	0.30	0.25
c	0.10	0.22	0.11
D	1.80	2.20	2.15
E	2.00	2.20	2.10
E1	1.15	1.35	1.30
e	0.650 BSC		
F	0.40	0.45	0.425
L	0.25	0.40	0.30
a	0°	8°	--
All Dimensions in mm			

**Package Outline Dimensions** (continued)

Please see <http://www.diodes.com/package-outlines.html> for the latest version.

**(3) Package Type: SOT553**

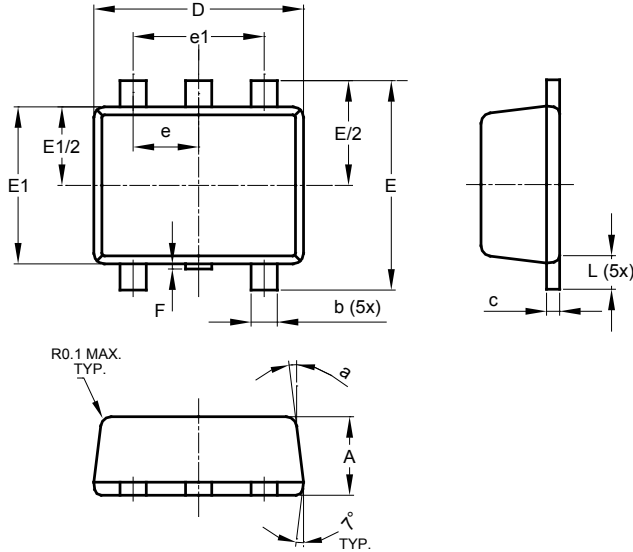

SOT553			
Dim	Min	Max	Typ
A	0.55	0.62	0.60
b	0.15	0.30	0.20
c	0.10	0.18	0.15
D	1.50	1.70	1.60
E	1.55	1.70	1.60
E1	1.10	1.25	1.20
e	0.50 BSC		
e1	1.00 BSC		
F	0.00	0.10	—
L	0.10	0.30	0.20
a	6°	8°	7°
All Dimensions in mm			

**(4) Package Type: X2-DFN0808-4**

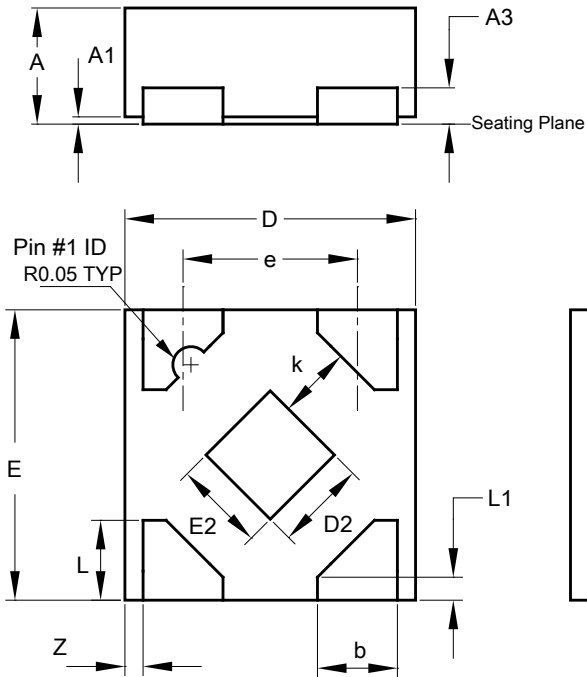

X2-DFN0808-4			
Dim	Min	Max	Typ
A	0.25	0.35	0.30
A1	0	0.04	0.02
A3	-	-	0.13
b	0.17	0.27	0.22
D	0.75	0.85	0.80
D2	0.15	0.35	0.25
E	0.75	0.85	0.80
E2	0.15	0.35	0.25
e	-	-	0.48
k	0.20	-	-
L	0.17	0.27	0.22
L1	0.02	0.12	0.07
z	-	-	0.05
All Dimensions in mm			

**Package Outline Dimensions** (continued)

Please see <http://www.diodes.com/package-outlines.html> for the latest version.

(5) Package Type: X2-DFN1010-6

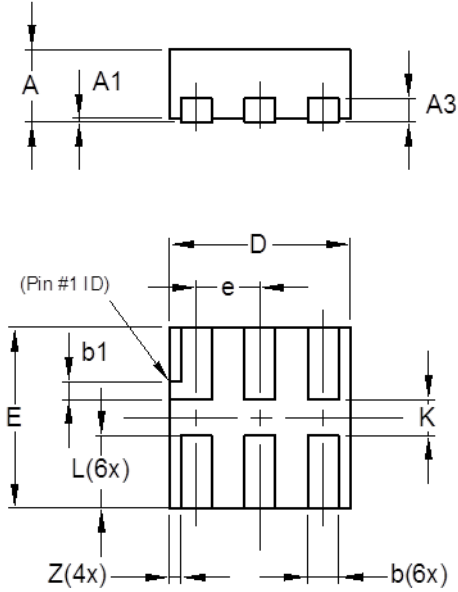

X2-DFN1010-6			
Dim	Min	Max	Typ
A	—	0.40	0.39
A1	0.00	0.05	0.02
A3	—	—	0.13
b	0.14	0.20	0.17
b1	0.05	0.15	0.10
D	0.95	1.05	1.00
E	0.95	1.05	1.00
e	—	—	0.35
L	0.35	0.45	0.40
K	0.15	—	—
Z	—	—	0.065
All Dimensions in mm			

(6) Package Type: X2-DFN1409-6

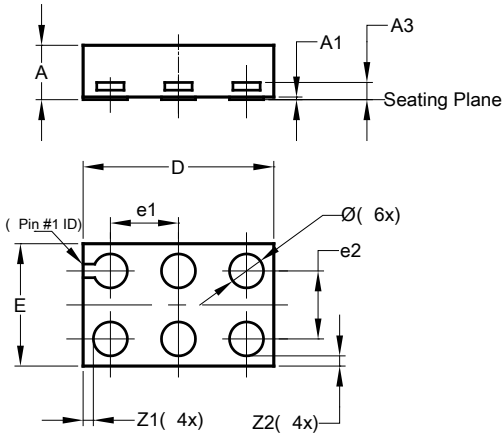

X2-DFN1409-6			
Dim	Min	Max	Typ
A	-	0.40	0.39
A1	0	0.05	0.02
A3	-	-	0.13
Ø	0.20	0.30	0.25
D	1.35	1.45	1.40
E	0.85	0.95	0.90
e1	-	-	0.50
e2	-	-	0.50
Z1	-	-	0.075
Z2	-	-	0.075
All Dimensions in mm			

**Package Outline Dimensions** (continued)

Please see <http://www.diodes.com/package-outlines.html> for the latest version.

(7) Package Type: X2-DFN1410-6

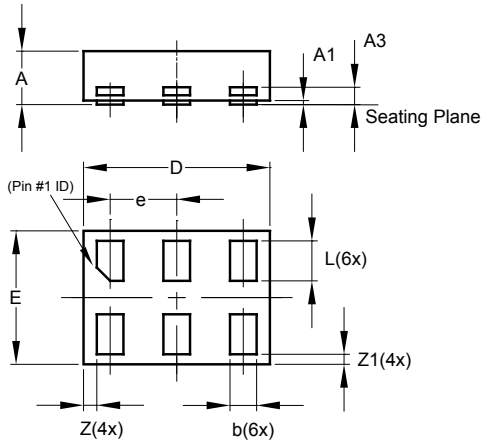

X2-DFN1410-6			
Dim	Min	Max	Typ
A	—	0.40	0.39
A1	0.00	0.05	0.02
A3	—	—	0.13
b	0.15	0.25	0.20
D	1.35	1.45	1.40
E	0.95	1.05	1.00
e	—	—	0.50
L	0.25	0.35	0.30
Z	—	—	0.10
Z1	0.045	0.105	0.075
All Dimensions in mm			

**Suggested Pad Layout**

Please see <http://www.diodes.com/package-outlines.html> for the latest version.

**(1) Package Type: SOT25**

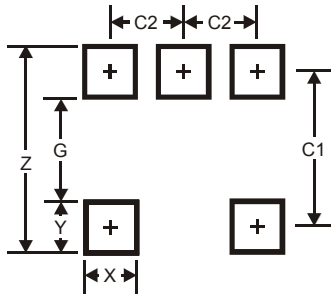

Dimensions	Value
Z	3.20
G	1.60
X	0.55
Y	0.80
C1	2.40
C2	0.95

**(2) Package Type: SOT353**

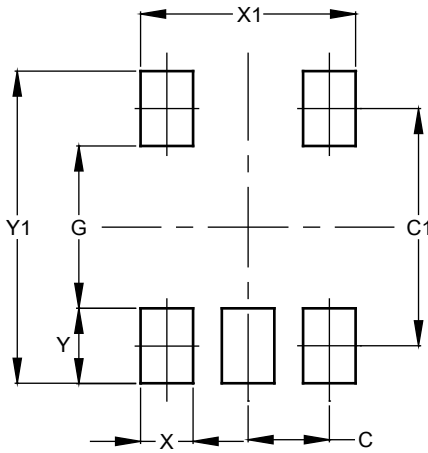

Dimensions	Value (in mm)
C	0.650
C1	1.900
G	1.300
X	0.420
X1	1.720
Y	0.600
Y1	2.500

**(3) Package Type: SOT553**

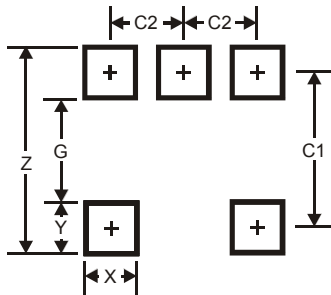

Dimensions	Value (in mm)
Z	2.2
G	1.2
X	0.375
Y	0.5
C1	1.7
C2	0.5

**Suggested Pad Layout** (continued)

Please see <http://www.diodes.com/package-outlines.html> for the latest version.

(4) Package Type: X2-DFN0808-4

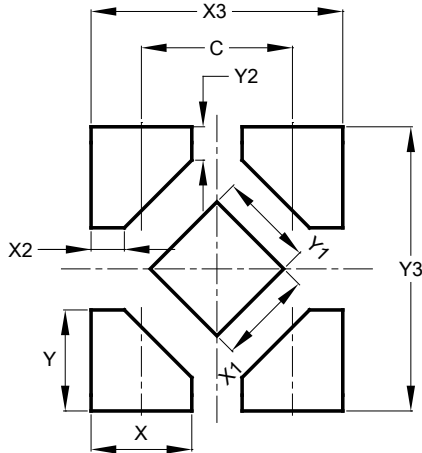

Dimensions	Value
C	0.480
X	0.320
X1	0.300
X2	0.106
X3	0.800
Y	0.320
Y1	0.300
Y2	0.106
Y3	0.900

(5) Package Type: X2-DFN1010-6

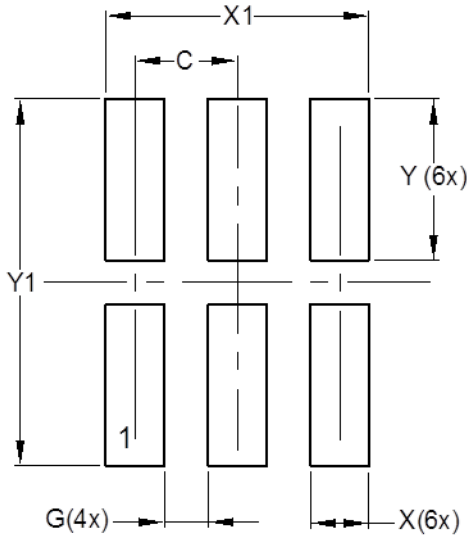

Dimensions	Value (in mm)
C	0.350
G	0.150
X	0.200
X1	0.900
Y	0.550
Y1	1.250

(6) Package Type: X2-DFN1409-6

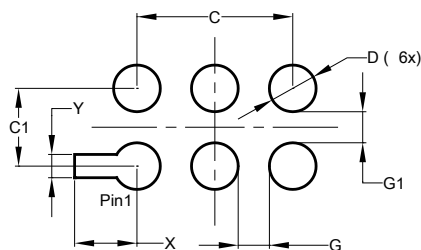

Dimensions	Value (in mm)
C	1.000
C1	0.500
D	0.300
G	0.200
G1	0.200
X	0.400
Y	0.150

## Suggested Pad Layout (continued)

Please see <http://www.diodes.com/package-outlines.html> for the latest version.

### (7) Package Type: X2-DFN1410-6

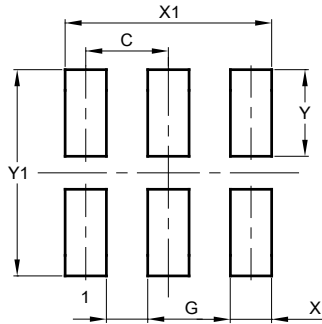

Dimensions	Value (in mm)
C	0.500
G	0.250
X	0.250
X1	1.250
Y	0.525
Y1	1.250

## Mechanical Data

### SOT25

- Moisture Sensitivity: Level 1 per J-STD-020
- Terminals: Finish - Matte Tin Plated Leads, Solderable per MIL-STD-202, Method 208 (e3)
- Weight: 0.016 grams (Approximate)

### SOT353

- Moisture Sensitivity: Level 1 per J-STD-020
- Terminals: Finish - Matte Tin Plated Leads, Solderable per MIL-STD-202, Method 208 (e3)
- Weight: 0.006 grams (Approximate)

### SOT553

- Moisture Sensitivity: Level 1 per J-STD-020
- Terminals: Finish - Matte Tin Plated Leads, Solderable per MIL-STD-202, Method 208 (e3)
- Weight: 0.003 grams (Approximate)

### X2-DFN0808-4

- Moisture Sensitivity: Level 1 per J-STD-020
- Terminals: Finish - NiPdAu Nickel Palladium Gold, Solderable per MIL-STD-202, Method 208 (e4)
- Weight: 0.001 grams (Approximate)

### X2-DFN1010-6

- Moisture Sensitivity: Level 1 per J-STD-020
- Terminals: Finish - NiPdAu Nickel Palladium Gold, Solderable per MIL-STD-202, Method 208 (e4)
- Weight: 0.001 grams (Approximate)

### X2-DFN1409-6

- Moisture Sensitivity: Level 1 per J-STD-020
- Terminals: Finish - NiPdAu Nickel Palladium Gold, Solderable per MIL-STD-202, Method 208 (e4)
- Weight: 0.002 grams (Approximate)

### X2-DFN1410-6

- Moisture Sensitivity: Level 1 per J-STD-020
- Terminals: Finish - NiPdAu Nickel Palladium Gold, Solderable per MIL-STD-202, Method 208 (e4)
- Weight: 0.002 grams (Approximate)

**IMPORTANT NOTICE**

1. DIODES INCORPORATED AND ITS SUBSIDIARIES (“DIODES”) MAKE NO WARRANTY OF ANY KIND, EXPRESS OR IMPLIED, WITH REGARDS TO ANY INFORMATION CONTAINED IN THIS DOCUMENT, INCLUDING, BUT NOT LIMITED TO, THE IMPLIED WARRANTIES OF MERCHANTABILITY, FITNESS FOR A PARTICULAR PURPOSE OR NON-INFRINGEMENT OF THIRD PARTY INTELLECTUAL PROPERTY RIGHTS (AND THEIR EQUIVALENTS UNDER THE LAWS OF ANY JURISDICTION).
2. The Information contained herein is for informational purpose only and is provided only to illustrate the operation of Diodes products described herein and application examples. Diodes does not assume any liability arising out of the application or use of this document or any product described herein. This document is intended for skilled and technically trained engineering customers and users who design with Diodes products. Diodes products may be used to facilitate safety-related applications; however, in all instances customers and users are responsible for (a) selecting the appropriate Diodes products for their applications, (b) evaluating the suitability of the Diodes products for their intended applications, (c) ensuring their applications, which incorporate Diodes products, comply the applicable legal and regulatory requirements as well as safety and functional-safety related standards, and (d) ensuring they design with appropriate safeguards (including testing, validation, quality control techniques, redundancy, malfunction prevention, and appropriate treatment for aging degradation) to minimize the risks associated with their applications.
3. Diodes assumes no liability for any application-related information, support, assistance or feedback that may be provided by Diodes from time to time. Any customer or user of this document or products described herein will assume all risks and liabilities associated with such use, and will hold Diodes and all companies whose products are represented herein or on Diodes’ websites, harmless against all damages and liabilities.
4. Products described herein may be covered by one or more United States, international or foreign patents and pending patent applications. Product names and markings noted herein may also be covered by one or more United States, international or foreign trademarks and trademark applications. Diodes does not convey any license under any of its intellectual property rights or the rights of any third parties (including third parties whose products and services may be described in this document or on Diodes’ website) under this document.
5. Diodes products are provided subject to Diodes’ Standard Terms and Conditions of Sale (<https://www.diodes.com/about/company/terms-and-conditions/terms-and-conditions-of-sales/>) or other applicable terms. This document does not alter or expand the applicable warranties provided by Diodes. Diodes does not warrant or accept any liability whatsoever in respect of any products purchased through unauthorized sales channel.
6. Diodes products and technology may not be used for or incorporated into any products or systems whose manufacture, use or sale is prohibited under any applicable laws and regulations. Should customers or users use Diodes products in contravention of any applicable laws or regulations, or for any unintended or unauthorized application, customers and users will (a) be solely responsible for any damages, losses or penalties arising in connection therewith or as a result thereof, and (b) indemnify and hold Diodes and its representatives and agents harmless against any and all claims, damages, expenses, and attorney fees arising out of, directly or indirectly, any claim relating to any noncompliance with the applicable laws and regulations, as well as any unintended or unauthorized application.
7. While efforts have been made to ensure the information contained in this document is accurate, complete and current, it may contain technical inaccuracies, omissions and typographical errors. Diodes does not warrant that information contained in this document is error-free and Diodes is under no obligation to update or otherwise correct this information. Notwithstanding the foregoing, Diodes reserves the right to make modifications, enhancements, improvements, corrections or other changes without further notice to this document and any product described herein. This document is written in English but may be translated into multiple languages for reference. Only the English version of this document is the final and determinative format released by Diodes.
8. Any unauthorized copying, modification, distribution, transmission, display or other use of this document (or any portion hereof) is prohibited. Diodes assumes no responsibility for any losses incurred by the customers or users or any third parties arising from any such unauthorized use.

Copyright © 2021 Diodes Incorporated

[www.diodes.com](http://www.diodes.com)

## Looking for pricing, stock, or lifecycle information?

Click below to explore more details on WIN SOURCE:

 [View 74LVC1G17Z-7 on WIN SOURCE](#)

 [Diodes Incorporated](#) Information

## Optimize Your Supply Chain with WIN SOURCE Solutions

-  Global Sourcing Solution
-  Obsolete Management
-  Cost Control Management
-  Shortage Management
-  Alternative Solution
-  Excess Inventory Management