



**THE DATASHEET OF
MLX90817LXE-DBG-003-SP**



1. Features and Benefits

- High accuracy absolute pressure sensor
- Ratiometric Analog Output
- System in a package: MEMS, analog front end circuitry, 16 bit microcontroller, analog back end circuitry, voltage regulators
- Large automotive temperature range (-40°C to 150°C)
- Automotive qualified and automotive diagnostic features (clamping levels, broken track diagnostics, multiple internal fault diagnostics)
- Factory calibrated or fully programmable or reconfigurable through the connector for customized calibration curves
- Assembled in a rugged easy to use 4x5mm DFN package

2. Application Examples

- Automotive applications with absolute pressure from 1bar to 5.5bar
- Manifold and Turbo Manifold Air Pressure
- Manifold and Turbo Manifold Air Pressure combined with Temperature
- LPG/CNG Injectors

3. Ordering Information

Product Code	Temperature Code	Package Code	Option Code	Packing Form Code
MLX90817	L	XE	DBG-001	RE
MLX90817	L	XE	DBG-003	RE
MLX90817	L	XE	DBH-008	RE
MLX90817	L	XE	DBG-010	RE
MLX90817	L	XE	DBG-012	RE
MLX90817	L	XE	DBH-014	RE
MLX90817	L	XE	DCG-000	RE
MLX90817	L	XE	DCH-008	RE

Legend:

Temperature Code: L (-40°C to 150°C)

Package Code: XE = DFN14

Option Code:
DBG-001 = 0.5 to 4bar absolute pressure / 0.5V to 4.5V output
DBG-003 = 0.2 to 5.5bar absolute pressure / 0.5V to 4.5V output
DBH-008 = 0.1 to 1.15bar absolute pressure / 0.4V to 4.65V output
DBG-010 = 0.2 to 2.5bar absolute pressure / 0.2V to 4.8V output
DBG-012 = 0.2 to 3bar absolute pressure / 0.4V to 4.65V output
DBH-014 = 0.133 to 1.199bar absolute pressure / 1V to 4.2V output
DCG-000 = 0.2 to 4bar absolute pressure / 0.4V to 4.65V output / harsh media
DCH-008 = 0.1 to 1.15bar absolute pressure / 0.4V to 4.65V output / harsh media

Packing Form: RE = Reel

Ordering example: MLX90817LXE-DBG-001-RE

MLX90817

Absolute Pressure Sensor IC

4. Functional Diagram

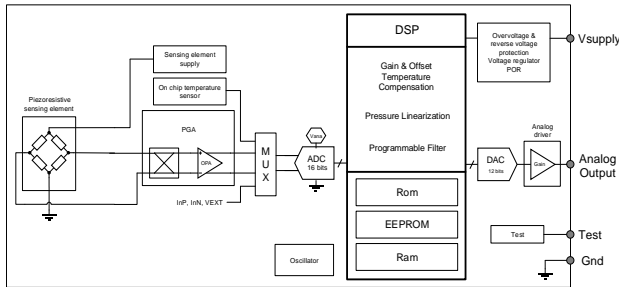

Figure 1: Functional block diagram

5. General Description

The MLX90817 is a packaged, factory calibrated, absolute pressure sensor delivering ratiometric analog output.

Use of an optimized architecture and a high density CMOS technology imparts the MLX90817 with best in class automotive EMC performance. A DSP based architecture using a 16bit microcontroller provides outstanding performance in terms of initial accuracy.

A smart package and die assembly concept suits applications with stringent automotive temperature and stress conditions needing small drift over life.

Contents

1. Features and Benefits	1
2. Application Examples	1
3. Ordering Information	1
4. Functional Diagram	2
5. General Description	2
6. Glossary of Terms	5
7. Absolute Maximum Ratings	5
8. Pin Definitions and Descriptions	6
9. General Electrical Specifications	7
10. Detailed General Description	8
11. Default programmed settings	9
11.1. Default Characteristics DBG-001	10
11.2. Default Characteristics DBG-003	10
11.3. Default Characteristics DBH-008	11
11.4. Default Characteristics DBG-010	11
11.5. Default Characteristics DBG-012	12
11.6. Default Characteristics DBH-014	12
11.7. Default Characteristics DCG-000	13
11.8. Default Characteristics DCH-008	13
12. Filters	14
12.1. PFLT	14
12.2. SSF	14
13. Analog Front End	15
14. ADC	17
15. Digital	17
16. Wrong Connections Overview	18
17. Diagnostics	18
17.1. Input Diagnostics	18
17.2. Diagnostic Sources	19
18. Application Information	20
19. PCB Land Pattern Recommendation	20

MLX90817

Absolute Pressure Sensor IC

20. Storage and handling of plastic encapsulated ICs	21
21. Assembly of encapsulated ICs	21
22. Environment and sustainability	21
23. Package Information for Option Codes DBx-xxx.....	22
24. Package Information for Option Codes DCx-xxx.....	23
25. Disclaimer.....	24

6. Glossary of Terms

- Bar: Pressure unit (1bar = 100kPa)
- POR: Power-on Reset
- ADC: Analog to Digital Converter
- DAC: Digital to Analog Converter
- DSP: Digital Signal Processor
- EMC: Electro Magnetic Compatibility
- Vbrg: Sensor bridge supply
- InP: Positive sensing element input
- InN: Negative sensing element input
- OV: Over Voltage
- UV: Under Voltage

7. Absolute Maximum Ratings

Exceeding the absolute maximum ratings may cause permanent damage. Exposure to absolute-maximum-rated conditions for extended periods may affect device reliability.

Parameter	Value	Units
Supply Voltage (overvoltage)	18	V
Reverse Voltage Protection	-14	V
Positive output voltage	18	V
Reverse output voltage	-0.5	V
Operating Temperature Range	-40 to 150	°C
Storage Temperature Range	-40 to 150	°C
Programming Temperature Range	-40 to 125	°C
Burst pressure (Room Temperature)	15	Bar

Table 1: Absolute maximum ratings

8. Pin Definitions and Descriptions

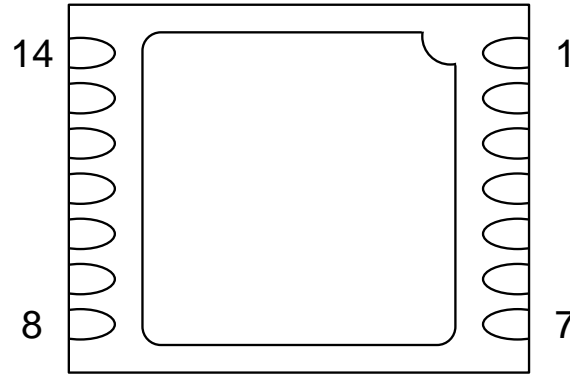

Figure 2: Package pinout (bottom view)

Pin number	Description	Pin number	Description
1	Test pin	14	Ground
2	Not Connected	13	Not Connected
3	Test pin	12	Not Connected
4	Not Connected	11	Not Connected
5	Test pin	10	Ground
6	Not Connected	9	Not Connected
7	Supply input	8	Output

Table 2: Pin out definitions and descriptions

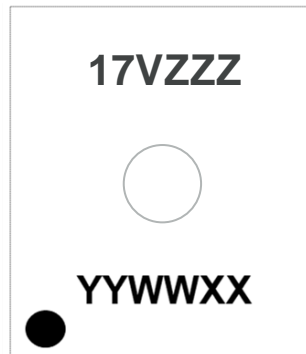

Figure 3: Package marking (top view)

Symbol	Function / Description
V	MEMS and ASIC traceability letter
ZZZ	Last 3 digits of ASIC lot number
YY	Year of assembly
WW	Calendar week of assembly
XX	Last 2 digits of the sensor lot #

Table 3: Package marking definition

9. General Electrical Specifications

DC Operating Parameters $T_A = -40^{\circ}\text{C}$ to 150°C

Parameter	Symbol	Remarks	Min	Typ ⁽¹⁾	Max	Units
Nominal supply voltage	Vdd		4.5	5	5.5	V
Nominal supply current	Idd	No output load connected		8.5	10	mA
Decoupling capacitor on supply			47	100		nF
Capacitive load on output	Cload		47	100	470	nF
Resistive load on output	Rload	Pull up or Pull down	4.7			kOhm
Supply programming entry level	Vdd_com	Threshold to enter communication mode	6.2	7	7.8	V
Analog POR level (rising)			3.1	3.5	3.9	V
Analog POR hysteresis			100		500	mV
Digital POR level (rising)			2.05	2.3	2.7	V
Digital POR hysteresis			10		200	mV
Nominal bridge supply voltage	Vbrg		-9%	3.5	+9%	V
Sensing element sensitivity		Option codes DBG-xxx and DCG-xxx		9		mV/V/bar
		Option codes DBH-xxx		18		mV/V/bar
Diagnostic limits	Diag low	Pull-up $\geq 4.7\text{k}\Omega$ Pull-down $\geq 4.7\text{k}\Omega$			3 3	%Vdd
	Diag high	Pull-up $\geq 4.7\text{k}\Omega$ Pull-down $\geq 8\text{k}\Omega$	96 96			%Vdd
Clamping levels	Clamp low	Programmable range with 7 bit resolution for the low clamping level, 9 for the high	0		12.5	%Vdd
	Clamp high		50		100	%Vdd
Analog saturation output level	Vsat high	Pull-up $\geq 4.7\text{k}\Omega$	97		100	%Vdd
		Pull-down $\geq 4.7\text{k}\Omega$	96		100	
Pull-down $\geq 10\text{k}\Omega$		97		100		
	Vsat low	Pull-up $\geq 4.7\text{k}\Omega$ Pull-down $\geq 4.7\text{k}\Omega$	0 0		3 3	%Vdd
Power up time		Time from reaching minimum allowed supply voltage of 4.5V till having the output within specification			1.3	ms
Response time		Time needed for the output to change from an input pressure step to 90% of its final value. Using the default filter settings PFLT=0 and SSF=1. For response times using different filter settings see Table 13.			1	ms

¹ Typical values are defined at $T_A = +25^{\circ}\text{C}$ and $V_{DD} = 5\text{V}$.

Parameter	Symbol	Remarks	Min	Typ ⁽¹⁾	Max	Units
ADC resolution				16		Bits
InP InN digital diagnostic levels		Diagnostic thresholds of 25% of VDDA (low) and 75% of VDDA (high)	-16384		16384	lsb
Output noise		BW limited to 50kHz.			2	mVrms

Table 4: Electrical specifications

10. Detailed General Description

The MLX90817 contains a pressure sensing element which consists of a diaphragm realized in the silicon chip by wafer bonding on an etched cavity with built in reference vacuum. The diaphragm reacts to a change in absolute pressure. The internal strain increases, in particular at the border of the diaphragm. Here, the piezo-resistive elements have been implanted into the silicon diaphragm forming a Wheatstone bridge, which act as a transducer.

The electronics front end amplifies the signal from the bridge, performs a coarse offset compensation and an ADC conversion. The DSP performs the compensations over temperature. Furthermore, the digital circuit provides some filtering, the possibility to linearize the pressure signal and also implements the clamping function. This chip delivers an analog output proportional to the pressure. A broken wire detection block allows actively driving the analog output to one of the rails in case of a broken supply or ground connection. Extensive protection of the supply lines allows the MLX90817 to handle extreme overvoltage conditions and is immune to severe external disturbances. Several diagnostic functions (over-voltage, under-voltage, overpressure, under pressure detections) have been implemented on the 90817 and can be enabled by programming EEPROM settings. Figure 4 describes MLX90817 block diagram.

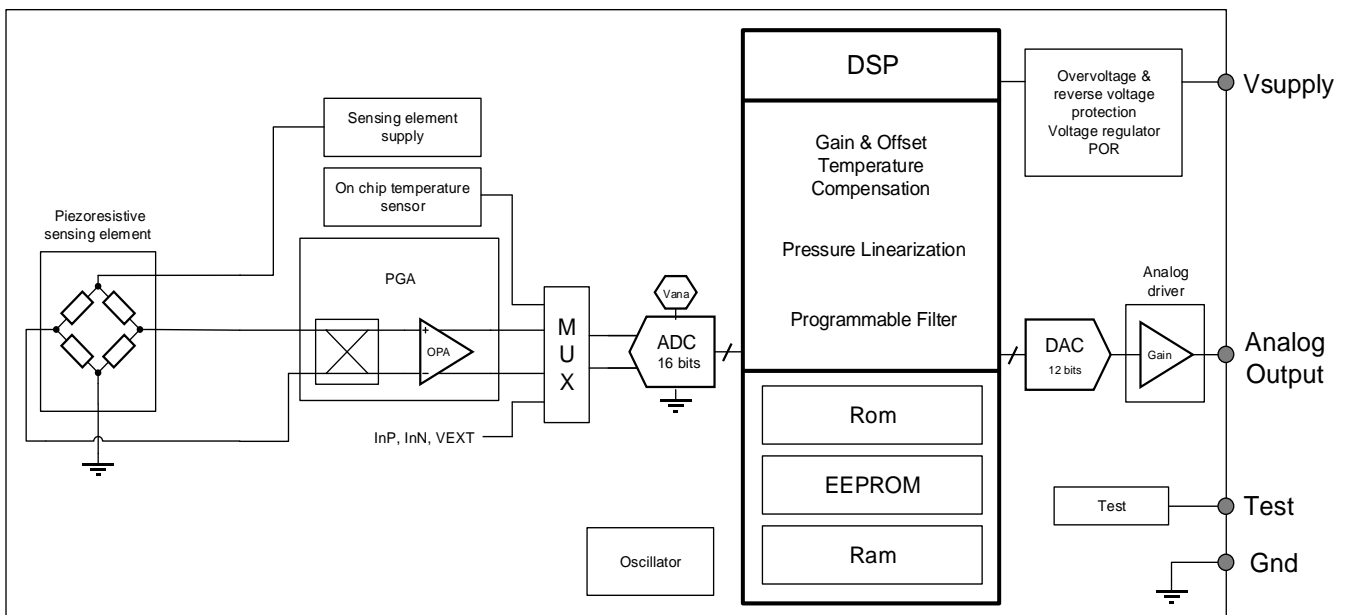

Figure 4: MLX90817 block diagram

11. Default programmed settings

The MLX90817 is calibrated at the final manufacturing test step. During the calibration, settings are stored in the on chip EEPROM to define the pressure transfer curve as well as the output clamping levels. Together with the transfer functions, the IC filter values are set.

The transfer curves as described below are valid assuming a supply voltage of 5V for the IC, the analog output scales in a ratiometric way to the supply voltage.

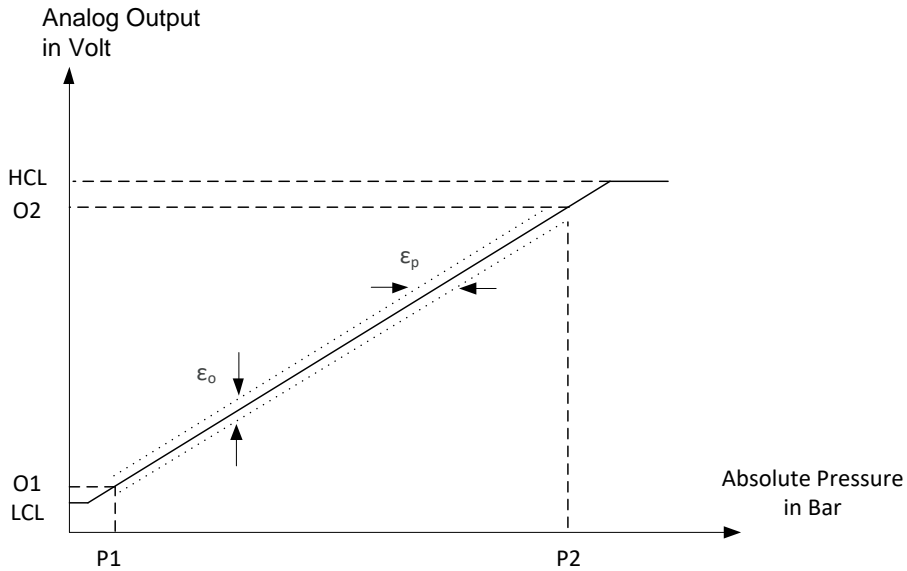

Figure 5: Pressure transfer function description at room temperature

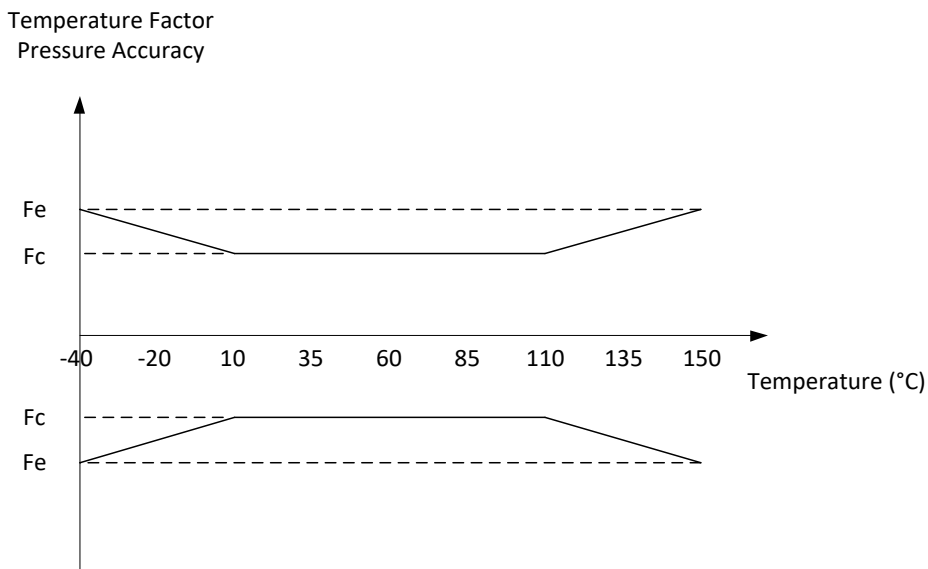

Figure 6: Pressure accuracy temperature factor

11.1. Default Characteristics DBG-001

Transfer Curve Parameter	Symbol	Remarks	Value			Unit
Pressure 1	P1	See Figure 5: Pressure transfer function description at room temperature	0.5			Bar
Pressure 2	P2		4			Bar
Output 1	O1		0.5			V
Output 2	O2		4.5			V
Low clamping level	LCL		0.3			V
High clamping level	HCL		4.7			V
Pressure Accuracy Parameter	Symbol	Remarks	Min	Typ	Max	Unit
Output accuracy	ϵ_o	Overall accuracy expressed as output value (FS range from 0.5V to 4.5V)	-40 -1		40 1	mV %FS
Pressure accuracy	ϵ_p	Overall accuracy expressed as pressure value	-35		35	mBar
Center temperature accuracy factor	Fc	See Figure 6: Pressure accuracy temperature factor			1	
Extended temperature accuracy factor	Fe				1.5	

Table 5: DBG-001 Default configuration

11.2. Default Characteristics DBG-003

Transfer Curve Parameter	Symbol	Remarks	Value			Unit
Pressure 1	P1	See Figure 5: Pressure transfer function description at room temperature	0.2			Bar
Pressure 2	P2		5.5			Bar
Output 1	O1		0.5			V
Output 2	O2		4.5			V
Low clamping level	LCL		0			V
High clamping level	HCL		5			V
Pressure Accuracy Parameter	Symbol	Remarks	Min	Typ	Max	Unit
Output accuracy	ϵ_o	Overall accuracy expressed as output value (FS range from 0.5V to 4.5V)	-40 -1		40 1	mV %FS
Pressure accuracy	ϵ_p	Overall accuracy expressed as pressure value	-53		53	mBar
Center temperature accuracy factor	Fc	See Figure 6: Pressure accuracy temperature factor			1	
Extended temperature accuracy factor	Fe				1.5	

Table 6: DBG-003 Default configuration

11.3. Default Characteristics DBH-008

Transfer Curve Parameter	Symbol	Remarks	Value			Unit
Pressure 1	P1	See Figure 5: Pressure transfer function description at room temperature	0.1			Bar
Pressure 2	P2		1.15			Bar
Output 1	O1		0.4			V
Output 2	O2		4.65			V
Low clamping level	LCL		0.3			V
High clamping level	HCL		4.7			V
Pressure Accuracy Parameter	Symbol	Remarks	Min	Typ	Max	Unit
Output accuracy	ϵ_o	Overall accuracy expressed as output value (FS range from 0.5V to 4.5V)	-50 -1.25		50 1.25	mV %FS
Pressure accuracy	ϵ_p	Overall accuracy expressed as pressure value	-12.5		12.5	mBar
Center temperature accuracy factor	Fc	See Figure 6: Pressure accuracy temperature factor			1	
Extended temperature accuracy factor	Fe				1.5	

Table 7: DBH-008 Default configuration

11.4. Default Characteristics DBG-010

Transfer Curve Parameter	Symbol	Remarks	Value			Unit
Pressure 1	P1	See Figure 5: Pressure transfer function description at room temperature	0.2			Bar
Pressure 2	P2		2.5			Bar
Output 1	O1		0.2			V
Output 2	O2		4.8			V
Low clamping level	LCL		0			V
High clamping level	HCL		5			V
Pressure Accuracy Parameter	Symbol	Remarks	Min	Typ	Max	Unit
Output accuracy	ϵ_o	Overall accuracy expressed as output value (FS range from 0.5V to 4.5V)	-65 -1.63		65 1.63	mV %FS
Pressure accuracy	ϵ_p	Overall accuracy expressed as pressure value	-33		33	mBar
Center temperature accuracy factor	Fc	See Figure 6: Pressure accuracy temperature factor			1	
Extended temperature accuracy factor	Fe				1.5	

Table 8: DBG-010 Default configuration

11.5. Default Characteristics DBG-012

Transfer Curve Parameter	Symbol	Remarks	Value			Unit
Pressure 1	P1	See Figure 5: Pressure transfer function description at room temperature	0.2			Bar
Pressure 2	P2		3			Bar
Output 1	O1		0.4			V
Output 2	O2		4.65			V
Low clamping level	LCL		0			V
High clamping level	HCL		5			V
Pressure Accuracy Parameter	Symbol	Remarks	Min	Typ	Max	Unit
Output accuracy	ϵ_o	Overall accuracy expressed as output value (FS range from 0.5V to 4.5V)	-50 -1.25		50 1.25	mV %FS
Pressure accuracy	ϵ_p	Overall accuracy expressed as pressure value	-33		33	mBar
Center temperature accuracy factor	Fc	See Figure 6: Pressure accuracy temperature factor			1	
Extended temperature accuracy factor	Fe				1.5	

Table 9: DBG-012 Default configuration

11.6. Default Characteristics DBH-014

Transfer Curve Parameter	Symbol	Remarks	Value			Unit
Pressure 1	P1	See Figure 5: Pressure transfer function description at room temperature	0.133			Bar
Pressure 2	P2		1.199			Bar
Output 1	O1		1			V
Output 2	O2		4.2			V
Low clamping level	LCL		0			V
High clamping level	HCL		5			V
Pressure Accuracy Parameter	Symbol	Remarks	Min	Typ	Max	Unit
Output accuracy	ϵ_o	Overall accuracy expressed as output value (FS range from 0.5V to 4.5V)	-45 -1.13		45 1.13	mV %FS
Pressure accuracy	ϵ_p	Overall accuracy expressed as pressure value	-15		15	mBar
Center temperature accuracy factor	Fc	See Figure 6: Pressure accuracy temperature factor			1	
Extended temperature accuracy factor	Fe				1.5	

Table 10: DBH-014 Default configuration

11.7. Default Characteristics DCG-000

Transfer Curve Parameter	Symbol	Remarks	Value			Unit
Pressure 1	P1	See Figure 5: Pressure transfer function description at room temperature	0.2			Bar
Pressure 2	P2		4			Bar
Output 1	O1		0.4			V
Output 2	O2		4.65			V
Low clamping level	LCL		0.3			V
High clamping level	HCL		4.7			V
Pressure Accuracy Parameter	Symbol	Remarks	Min	Typ	Max	Unit
Output accuracy	ϵ_o	Overall accuracy expressed as output value (FS range from 0.5V to 4.5V)	-32 -0.8		32 0.8	mV %FS
Pressure accuracy	ϵ_p	Overall accuracy expressed as pressure value	-28.6		28.6	mBar
Center temperature accuracy factor	Fc	See Figure 6: Pressure accuracy temperature factor			1	
Extended temperature accuracy factor	Fe				1.5	

Table 11: DCG-000 Default configuration

11.8. Default Characteristics DCH-008

Transfer Curve Parameter	Symbol	Remarks	Value			Unit
Pressure 1	P1	See Figure 5: Pressure transfer function description at room temperature	0.1			Bar
Pressure 2	P2		1.15			Bar
Output 1	O1		0.4			V
Output 2	O2		4.65			V
Low clamping level	LCL		0.3			V
High clamping level	HCL		4.7			V
Pressure Accuracy Parameter	Symbol	Remarks	Min	Typ	Max	Unit
Output accuracy	ϵ_o	Overall accuracy expressed as output value (FS range from 0.5V to 4.5V)	-50 -1.25		50 1.25	mV %FS
Pressure accuracy	ϵ_p	Overall accuracy expressed as pressure value	-12.5		12.5	mBar
Center temperature accuracy factor	Fc	See Figure 6: Pressure accuracy temperature factor			1	
Extended temperature accuracy factor	Fe				1.5	

Table 12: DCH-008 Default configuration

12. Filters

There are two filters available to filter the pressure signal. The first filter is a Small Signal Filter which can be disabled or enabled. The second filter is a first order low pass filter for the pressure signal which has a programmable depth.

12.1. PFLT

PFLT is a programmable first order low pass filter. The depth of this filter can be selected. This filter can be configured to select the optimal trade-off between response time and output noise.

The low pass filter is implemented according to the following formula:

$$Filter_{output}(k) = \frac{Filter_{input}(k) - Filter_{output}(k - 1)}{2^{PFLT}} + Filter_{output}(k - 1)$$

The PFLT parameter in the formula is set in EEPROM and can have a value between 0 and 9. An overview of typical response times when applying a step on the input using different PFLT filter settings can be found in Table 13. Filter setting 0 disables the PFLT.

PFLT setting	Response time in ms ⁽²⁾
0	0.93
1	1.25
2	2
3	3.7
4	7.1
5	13.7
6	27.0
7	53.8
8	106.8
9	203.8

Table 13: Filter settings and typical response times

12.2. SSF

The SSF (Small Signal Filter) is a digital filter which is designed not to have an impact on the response time of a fast changing pressure signal like a pressure step. When a large signal change at the input is present, the filter is bypassed and not filtering the signal. For small signal changes, which are in most cases noise, the filter is used and filtering the pressure signal.

The Small Signal Filter can be enabled or disabled in EEPROM.

² Time needed for the output to change from an input pressure step to 90% of its final value.

13. Analog Front End

The analog front end of the MLX90817 consists of a chopping stage and 3 amplification stages as can be seen in Figure 7. There are also several input diagnostics integrated into this front end to be able to detect a broken InP or InN connection or an input which is out of range. This diagnostic information is transferred to the microcontroller to handle further action for example flagging a diagnostic message.

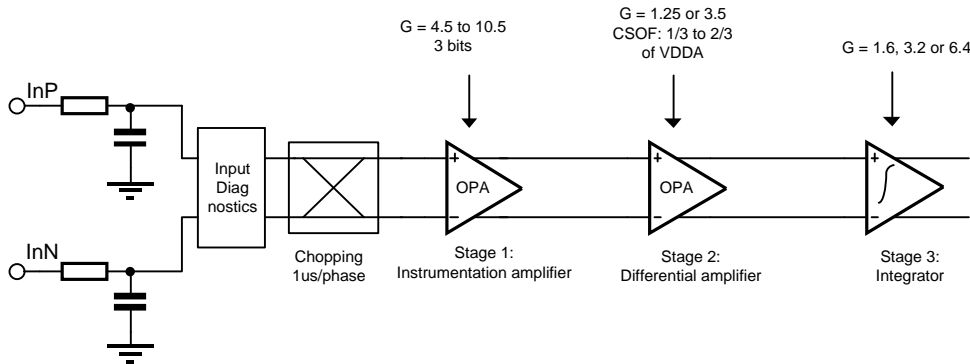

Figure 7: Analog front end block diagram

The first stage is an instrumentation amplifier of which the gain can be programmed using 3 bits to cover a gain range between 4.5 and 10.6.

Transfer equation:

$$\text{OUTP1} - \text{OUTN1} = \text{Gst1} * (\text{InP} - \text{InN}) \text{ in phase 1}$$

$$\text{OUTP1} - \text{OUTN1} = \text{Gst1} * (\text{InN} - \text{InP}) \text{ in phase 2}$$

The second stage is a fully differential amplifier. The gain of the amplifier can be calibrated using 1 bit.

Transfer equation:

$$\text{OUTP2} - \text{OUTN2} = -\text{Gst2} * (\text{OUTP1} - \text{OUTN1}) - \text{Gst2} * (\text{CSOF1} - \text{CSOF2}) \text{ in phase 1}$$

$$\text{OUTP2} - \text{OUTN2} = -\text{Gst2} * (\text{OUTN1} - \text{OUTP1}) - \text{Gst2} * (\text{CSOF2} - \text{CSOF1}) \text{ in phase 2}$$

The CSOF1 and CSOF2 signals are generated by the coarse offset DAC with the following transfer functions:

$$\text{CSOF1} = \frac{\text{VDDA}}{2} + (-1)^{\text{CO7}} * \left(\frac{2}{3} - \frac{1}{3} \right) * \frac{\text{VDDA}}{2} * \frac{\text{CO}[6:0]}{127}$$

$$\text{CSOF2} = \frac{\text{VDDA}}{2} - (-1)^{\text{CO7}} * \left(\frac{2}{3} - \frac{1}{3} \right) * \frac{\text{VDDA}}{2} * \frac{\text{CO}[6:0]}{127}$$

CO[6:0] fixes the DAC output. CO7 is used for the polarity.

The third stage is an integrator which is controlled using 2 bits to set a gain between 1.6 and 6.4

Transfer equation at the outputs of the amplifier:

$$\text{OUTP3} - \text{OUTN3} = -\text{N} * (\text{C1}/\text{C2}) * (\text{OUTP2} - \text{OUTN2})$$

$$\text{OUTP3_common_mode} \text{ and } \text{OUTN3_common_mode} = \text{VCM} = \text{VDDA}/2$$

In this equation N represents the number of integration cycles which is a fixed value of N = 40.

C2 is a fixed feedback capacitor of approximately 5pF. C1 can have 3 different values: 0.2pF, 0.4pF or 0.8pF.

Transfer equation after the ADC:

$$\text{Pressure_ADC} = ((\text{OUTN3} - \text{OUTP3}) * 2^{16} / \text{VDDA}) + 32768$$

An overview of all possible values for Gst1, Gst2 and Gst3 can be found in Table 14 below.

The input stage is designed to work with an input common-mode voltage range between 42%Vbrg and 58%Vbrg.

Gain setting [-]	Gst1 [V/V]	Gst2 [V/V]	Gst3 [V/V]	Total gain [V/V]	FS Differential input signal [mV]
0	4.49	-1.25	1.6	-9.0	± 195
1	5.06	-1.25	1.6	-10.1	± 173
2	5.8	-1.25	1.6	-11.6	± 151
3	6.52	-1.25	1.6	-13.0	± 134
4	7.43	-1.25	1.6	-14.9	± 118
5	8.37	-1.25	1.6	-16.7	± 105
6	9.35	-1.25	1.6	-18.7	± 94
7	10.6	-1.25	1.6	-21.2	± 83
8	4.49	-3.5	1.6	-25.1	± 70
9	5.06	-3.5	1.6	-28.3	± 62
10	5.8	-3.5	1.6	-32.5	± 54
11	6.52	-3.5	1.6	-36.5	± 48
12	7.43	-3.5	1.6	-41.6	± 42
13	8.37	-3.5	1.6	-46.9	± 37
14	9.35	-3.5	1.6	-52.4	± 33
15	10.6	-3.5	1.6	-59.4	± 29
16	4.49	-3.5	3.2	-50.3	± 35
17	5.06	-3.5	3.2	-56.7	± 31
18	5.8	-3.5	3.2	-65.0	± 27
19	6.52	-3.5	3.2	-73.0	± 24
20	7.43	-3.5	3.2	-83.2	± 21
21	8.37	-3.5	3.2	-93.7	± 19
22	9.35	-3.5	3.2	-104.7	± 17
23	10.6	-3.5	3.2	-118.7	± 15
24	4.49	-3.5	6.4	-100.6	± 17
25	5.06	-3.5	6.4	-113.3	± 15
26	5.8	-3.5	6.4	-129.9	± 13
27	6.52	-3.5	6.4	-146.0	± 12
28	7.43	-3.5	6.4	-166.4	± 11
29	8.37	-3.5	6.4	-187.5	± 9
30	9.35	-3.5	6.4	-209.4	± 8
31	10.6	-3.5	6.4	-237.4	± 7

Table 14: Gain and input signal range of the analog front end

14. ADC

The 16 bit differential ADC has a range from $-VDDA/2$ to $+VDDA/2$.

There are 7 different ADC channels. Channel 0 is not used. Table 15 below describes all the channels.

ADC	Signal	Remarks
SIN[2:0]		
0	-	Nothing connected
1	P	Pressure
2	Tint	Internal Temperature
3	Vsup	External Supply
4	InP/InN	Multiplexing between Positive/Negative Sensor Output
5	Vdig	Digital Regulator
6	Tntc	NTC Output
7	Text	External Temperature

Table 15: ADC channels

The different channels are converted in a constantly repeating sequence. A new ADC conversion is done every 50us following the sequence shown below in Figure 8. This is resulting in an updated pressure output value every 200us.

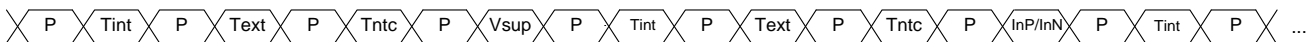

Figure 8: ADC sequence

15. Digital

The digital is built around a 16-bit microcontroller. It contains besides the processor also ROM, RAM and EEPROM and a set of user and system IO registers.

Temperature compensation of the pressure signal and pressure linearization is handled by the microcontroller. For the pressure compensation there are EEPROM parameters allocated to be able to cover a large variety of calibration approaches.

Both for gain and offset of the pressure signal, there is a separate temperature dependency programmable ranging from a temperature independence to a first order, second order and finally a third order compensation. This is reflected in EEPROM parameters for the offset (O0, O1, O2 and O3) and for the gain (G0, G1, G2 and G3). If required, the linearity of the pressure signal can also be compensated without a temperature dependency or with a first order temperature dependency through EEPROM parameters L0 and L1.

16. Wrong Connections Overview

Table 16 provides an overview of the behavior of the MLX90817 when different combinations of connections to GND, VDD and OUT are made.

GND	VDD	Analog out	Effect on output	Action after wrong connection
0V	5V	Pull-down or Pull-up	Normal operation	Normal operation
Disconnected	5V	Pull-down or Pull-up	High Fault Band	Normal operation
0V	Disconnected	Pull-down or Pull-up	Low Fault Band	Normal operation
0V	5V	Disconnected	Low Fault Band for Pull-down High Fault Band for Pull-up	Normal operation
0V	5V	0V	Low Fault Band	Normal operation
0V	5V	5V	High Fault Band	Normal operation
0V	5V	18V	18V	Normal operation
0V	0V	Pull-down or Pull-up	Low Fault Band	Normal operation
0V	18V	Pull-down or Pull-up	Low Fault Band for Pull-down High Fault Band for Pull-up	Normal operation
5V	5V	Pull-down or Pull-up	High Fault Band	Normal operation
5V	0V	Pull-down or Pull-up		Normal operation

Table 16: Wrong connections overview

17. Diagnostics

17.1. Input Diagnostics

An overview of the different input diagnostics conditions and their corresponding fault band and diagnostic source can be found in Table 17.

Condition	Fault Band	Diagnostic Source
Vbrg disconnected	Low	ERR_EN_SPSN
GND (sensor) disconnected	Low	ERR_EN_SPSN
InP disconnected	Low	ERR_EN_BW
InN disconnected	Low	ERR_EN_BW
Vbrg shorted to GND	Low	ERR_EN_SPSN
InP shorted to GND	Low	ERR_EN_SPSN
InN shorted to GND	Low	ERR_EN_SPSN
InP shorted to Vbrg	Low	ERR_EN_SPSN
InN shorted to Vbrg	Low	ERR_EN_SPSN

Table 17: Input diagnostics

17.2. Diagnostic Sources

The MLX90817 product has several internal checks which monitor the status of device. These checks or diagnostic sources can be enabled or disabled based on the sensor module requirements. An overview of the different diagnostic sources, their enable/disable parameter and the explanation of their functionality can be found below in Table 18. The default diagnostic configuration for the different option codes can be found in Table 19.

Parameter	Error condition
ERR_EN_TINT	The Internal temperature could not be measured/calculated
ERR_EN_IO	RAM configuration error
ERR_EN_SPSN	SP or SN pin voltage out of range
ERR_EN_PV	The pressure value could not be measured/calculated
ERR_EN_PP	Pressure parameter error
ERR_EN_BW	A broken wire is detected in the pressure sensor path
ERR_EN_VSUPH	The supply voltage is too high
ERR_EN_VSUPL	The supply voltage is too low
ERR_EN_TCHIP	The chip temperature out of range

Table 18: Diagnostic sources

Parameter	Dxx-001	Dxx-003	Dxx-008	Dxx-010	Dxx-012	Dxx-014	Dxx-000
ERR_EN_TINT	✗	✗	✗	✗	✗	✗	✗
ERR_EN_IO	✓	✓	✓	✓	✓	✗	✓
ERR_EN_SPSN	✓	✓	✓	✓	✓	✗	✓
ERR_EN_PV	✓	✓	✓	✓	✓	✗	✓
ERR_EN_PP	✓	✓	✓	✓	✓	✗	✓
ERR_EN_BW	✓	✓	✓	✓	✓	✗	✓
ERR_EN_VSUPH	✗	✗	✗	✗	✗	✗	✗
ERR_EN_VSUPL	✗	✗	✗	✗	✗	✗	✗
ERR_EN_TCHIP	✓	✓	✓	✓	✓	✗	✓

Table 19: Default diagnostic configuration

The level of the over and under voltage diagnostics can be configured according to the ranges described in Table 20.

Parameter	Min	Max	Units	Comment
Under voltage detection threshold range	3.25	5.74	V	Optional and Programmable with 8 bits in parameter VSUP_LOW
Overvoltage detection threshold range	4.25	6.74	V	Optional and Programmable with 8 bits in parameter VSUP_HIGH
Over-/Under-voltage detection accuracy		200	mV	

Table 20: MLX90817 under and overvoltage detection

18. Application Information

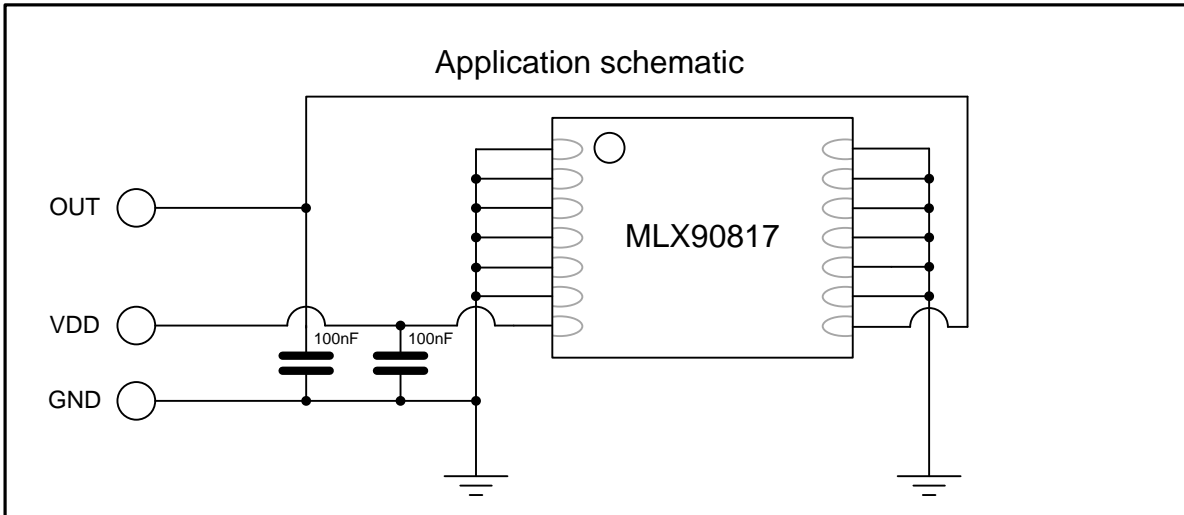
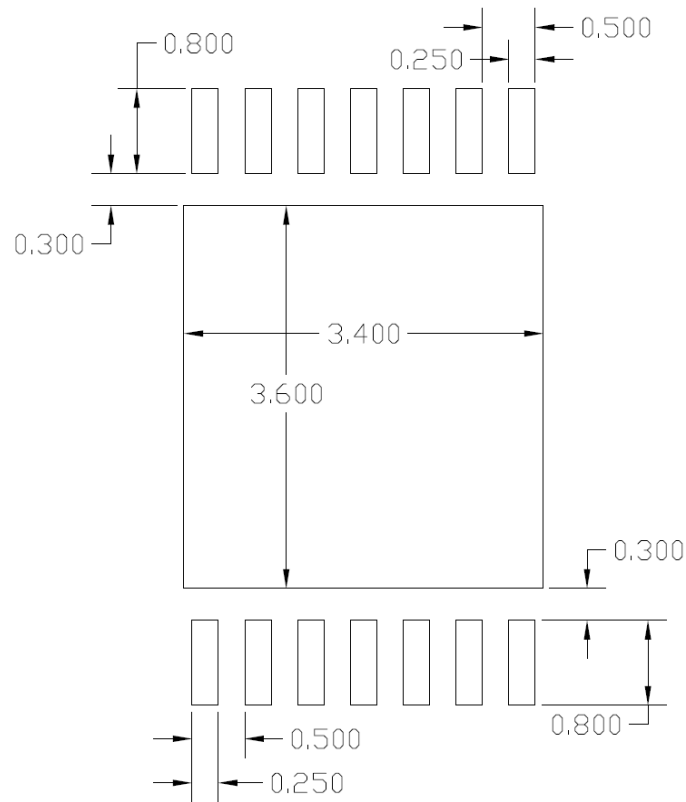

Figure 9: Basic application schematic

These recommendations for external components are only providing a basic protection. Depending on the module design and the EMC speciation requirements different configurations can be needed.

19. PCB Land Pattern Recommendation



Unit: mm

Figure 10: PCB Land Pattern

20. Storage and handling of plastic encapsulated ICs

Plastic encapsulated ICs shall be stored and handled according to their MSL categorization level (specified in the packing label) as per J-STD-033.

Electronic semiconductor products are sensitive to Electro Static Discharge (ESD). The component assembly shall be handled in EPA (Electrostatic Protected Area) as per ANSI S20.20

For more information refer to Melexis [Guidelines for storage and handling of plastic encapsulated ICs](#) ⁽³⁾

21. Assembly of encapsulated ICs

For Surface Mounted Devices (SMD, as defined according to JEDEC norms), the only applicable soldering method is reflow.

For Through Hole Devices (THD), the applicable soldering methods are reflow, wave, selective wave and robot point-to-point. THD lead pre-forming (cutting and/or bending) is applicable under strict compliance with Melexis [Guidelines for lead forming of SIP Hall Sensors](#) ⁽³⁾.

Melexis products soldering on PCB should be conducted according to the requirements of IPC/JEDEC and J-STD-001. Solder quality acceptance should follow the requirements of IPC-A-610.

For PCB-less assembly refer to the relevant application notes ⁽³⁾ or contact Melexis.

Electrical resistance welding or laser welding can be applied to Melexis products in THD and specific PCB-less packages following the [Guidelines for welding of PCB-less devices](#) ⁽³⁾.

Environmental protection of customer assembly with Melexis products for harsh media application, is applicable by means of coating, potting or overmolding considering restrictions listed in the relevant application notes ⁽³⁾

For other specific process, contact Melexis via www.melexis.com/technical-inquiry

22. Environment and sustainability

Melexis is contributing to global environmental conservation by promoting non-hazardous solutions. For more information on our environmental policy and declarations (RoHS, REACH...) visit www.melexis.com/environmental-forms-and-declarations

³ www.melexis.com/ic-handling-and-assembly

23. Package Information for Option Codes DBx-xxx

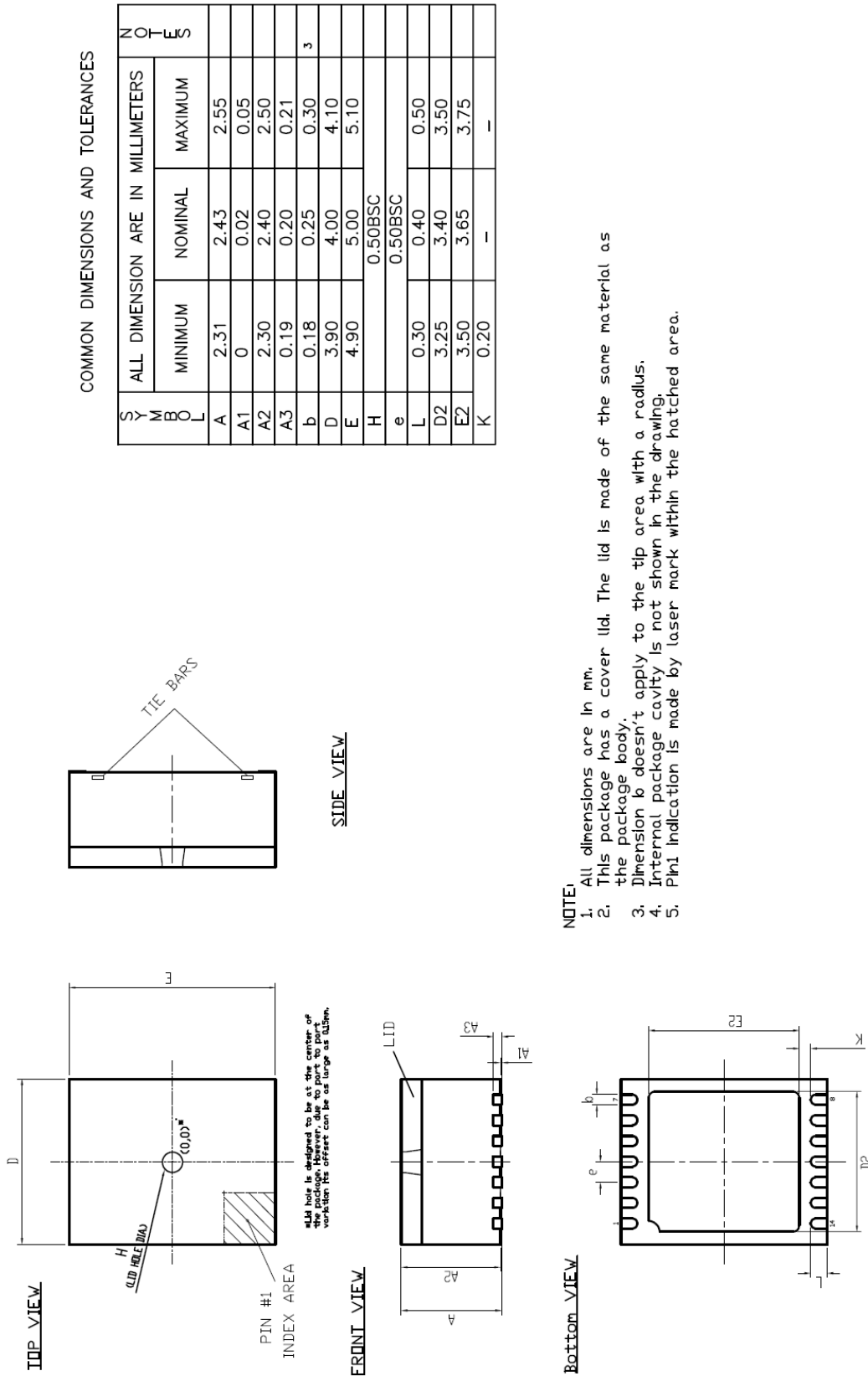

Figure 11: MLX90817 package drawing option codes DBx-xxx

24. Package Information for Option Codes DCx-xxx

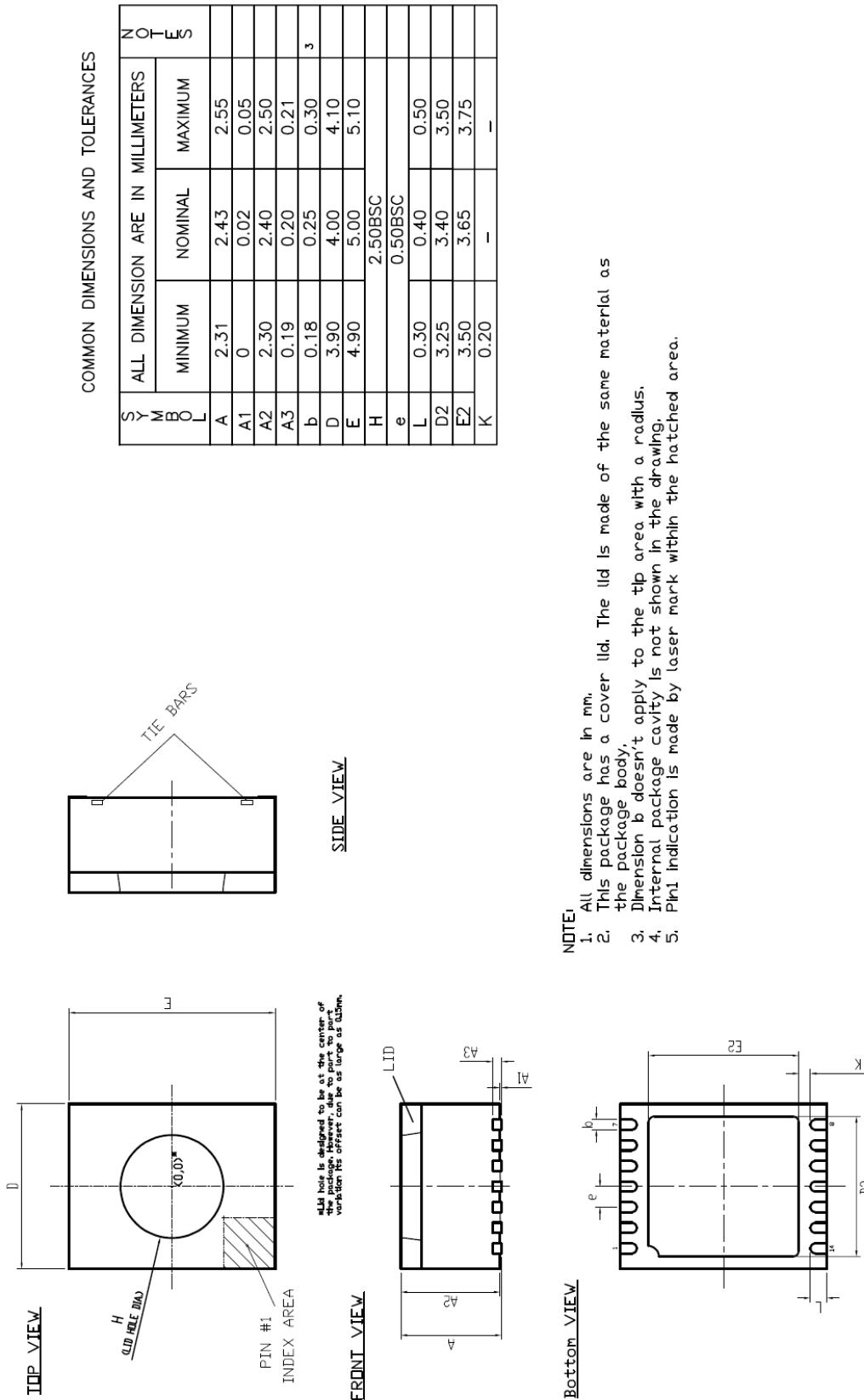

Figure 12: MLX90817 package drawing option codes DCx-xxx

25. Disclaimer

The content of this document is believed to be correct and accurate. However, the content of this document is furnished "as is" for informational use only and no representation, nor warranty is provided by Melexis about its accuracy, nor about the results of its implementation. Melexis assumes no responsibility or liability for any errors or inaccuracies that may appear in this document. Customer will follow the practices contained in this document under its sole responsibility. This documentation is in fact provided without warranty, term, or condition of any kind, either implied or expressed, including but not limited to warranties of merchantability, satisfactory quality, non-infringement, and fitness for purpose. Melexis, its employees and agents and its affiliates' and their employees and agents will not be responsible for any loss, however arising, from the use of, or reliance on this document. Notwithstanding the foregoing, contractual obligations expressly undertaken in writing by Melexis prevail over this disclaimer.

This document is subject to change without notice, and should not be construed as a commitment by Melexis. Therefore, before placing orders or prior to designing the product into a system, users or any third party should obtain the latest version of the relevant information.

Users or any third party must determine the suitability of the product described in this document for its application, including the level of reliability required and determine whether it is fit for a particular purpose.

This document as well as the product here described may be subject to export control regulations. Be aware that export might require a prior authorization from competent authorities. The product is not designed, authorized or warranted to be suitable in applications requiring extended temperature range and/or unusual environmental requirements. High reliability applications, such as medical life-support or life-sustaining equipment or avionics application are specifically excluded by Melexis. The product may not be used for the following applications subject to export control regulations: the development, production, processing, operation, maintenance, storage, recognition or proliferation of:

- 1. chemical, biological or nuclear weapons, or for the development, production, maintenance or storage of missiles for such weapons;*
- 2. civil firearms, including spare parts or ammunition for such arms;*
- 3. defense related products, or other material for military use or for law enforcement;*
- 4. any applications that, alone or in combination with other goods, substances or organisms could cause serious harm to persons or goods and that can be used as a means of violence in an armed conflict or any similar violent situation.*

No license nor any other right or interest is granted to any of Melexis' or third party's intellectual property rights.

If this document is marked "restricted" or with similar words, or if in any case the content of this document is to be reasonably understood as being confidential, the recipient of this document shall not communicate, nor disclose to any third party, any part of the document without Melexis' express written consent. The recipient shall take all necessary measures to apply and preserve the confidential character of the document. In particular, the recipient shall (i) hold document in confidence with at least the same degree of care by which it maintains the confidentiality of its own proprietary and confidential information, but no less than reasonable care; (ii) restrict the disclosure of the document solely to its employees for the purpose for which this document was received, on a strictly need to know basis and providing that such persons to whom the document is disclosed are bound by confidentiality terms substantially similar to those in this disclaimer; (iii) use the document only in connection with the purpose for which this document was received, and reproduce document only to the extent necessary for such purposes; (iv) not use the document for commercial purposes or to the detriment of Melexis or its customers. The confidentiality obligations set forth in this disclaimer will have indefinite duration and in any case they will be effective for no less than 10 years from the receipt of this document.

This disclaimer will be governed by and construed in accordance with Belgian law and any disputes relating to this disclaimer will be subject to the exclusive jurisdiction of the courts of Brussels, Belgium.

The invalidity or ineffectiveness of any of the provisions of this disclaimer does not affect the validity or effectiveness of the other provisions.

The previous versions of this document are repealed.

Melexis © - No part of this document may be reproduced without the prior written consent of Melexis. (2023)

IATF 16949 and ISO 14001 Certified

Looking for pricing, stock, or lifecycle information?

Click below to explore more details on WIN SOURCE:

- ⊖ [View MLX90817LXE-DBG-003-SP on WIN SOURCE](#)
- ⊖ [Melexis Technologies NV Information](#)

Optimize Your Supply Chain with WIN SOURCE Solutions

- ✓ Global Sourcing Solution
- ✓ Obsolete Management
- ✓ Cost Control Management
- ✓ Shortage Management
- ✓ Alternative Solution
- ✓ Excess Inventory Management