



**THE DATASHEET OF
KTD2801ECD-TR**



Pin Descriptions

Pin #		Name	Function
TDFN22-6	TSOT-23-6		
1	4	CTRL	IC control pin. Can be used to enable/disable the IC, as well as to program the output current using ExpressWire Control or PWM dimming.
2	6	VIN	Input supply pin for the IC
3	5	VOUT	Output voltage pin
4	3	FB	Feedback voltage pin
5	2	GND	Converter/IC ground
6	1	LX	Switching node of the step-up converter
MC	-	MC	Metal chassis. Connect to ground for electrical and thermal usage. (TDFN22-6 PKG only)

TDFN22-6 PKG
(Top View)

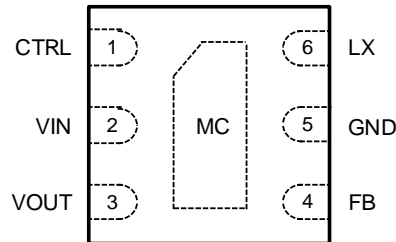

TSOT-23-6 PKG
(Top View)

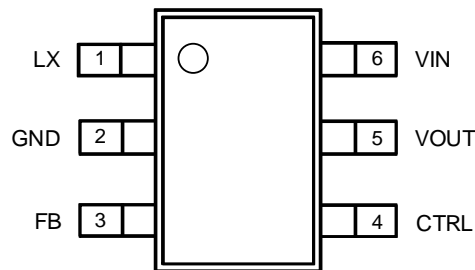

Absolute Maximum Ratings¹

(T_A=25°C unless otherwise noted)

Symbol	Description	Value	Units
V _{IN}	Input voltage	-0.3 to 6.0	V
LX, V _{OUT}	High voltage nodes	KTD2801	-0.3 to 40
		KTD2801A	-0.3 to 34
		KTD2801B	-0.3 to 28
FB, CTRL	Other pins	-0.3 to V _{IN} +0.3	V
T _J	Operating Temperature Range	-40 to 150	°C
T _s	Storage Temperature Range	-65 to 150	°C
T _{LEAD}	Maximum Soldering Temperature (at leads, 10 sec)	300	°C

Thermal Capabilities

Symbol	Description	Value	Units
TDFN22-6			
θ _{JA}	Thermal Resistance – Junction to Ambient ²	65	°C/W
P _D	Maximum Power Dissipation at T _A ≤ 25°C	1.54	W
ΔP _D /°C	Derating Factor Above T _A = 25°C	-15.4	mW/°C
TSOT23-6			
θ _{JA}	Thermal Resistance – Junction to Ambient ²	190	°C/W
P _D	Maximum Power Dissipation at T _A ≤ 25°C	0.526	W
ΔP _D /°C	Derating Factor Above T _A = 25°C	-1.9	mW/°C

Ordering Information

Part Number	OVP Threshold (nominal)	Marking ³	Operating Temperature	Package
KTD2801ECD-TR	36V	FFYYZ	-40°C to +85°C	TDFN22-6
KTD2801AEC-TR	30V	FUYYZ	-40°C to +85°C	TDFN22-6
KTD2801BEC-TR	24V	FGYYZ	-40°C to +85°C	TDFN22-6
KTD2801EHD-TR	36V	FFYYZ	-40°C to +85°C	TSOT23-6
KTD2801AHD-TR	30V	FUYYZ	-40°C to +85°C	TSOT23-6
KTD2801BED-TR	24V	FGYYZ	-40°C to +85°C	TSOT23-6

- Stresses above those listed in Absolute Maximum Ratings may cause permanent damage to the device. Functional operation at conditions other than the operating conditions specified is not implied. Only one Absolute Maximum rating should be applied at any one time.
- Junction to Ambient thermal resistance is highly dependent on PCB layout. Values are based on thermal properties of the device when soldered to an EV board.
- “YYZ” is the date code and assembly code.

Electrical Characteristics⁴

Unless otherwise noted, the *Min* and *Max* specs are applied over the full operation temperature range of -40°C to $+85^{\circ}\text{C}$, while *Typ* values are specified at room temperature (25°C). $V_{\text{IN}} = 3.6\text{V}$.

Symbol	Description	Conditions	Min	Typ	Max	Units
IC Supply						
V_{IN}	Input operating range		2.7		5.5	V
UVLO	Input under voltage lockout	Rising edge		2.5	2.65	V
UVLO _{HYST}	UVLO hysteresis			0.15		V
I_{Q}	IC standby current	Not switching		0.28	0.5	mA
	IC operating current	Switching		0.7	1.65	mA
I_{SHDN}	V_{IN} pin shutdown current	CTRL = GND		0.1	1.0	μA
Step-Up Converter						
V_{FB}	FB pin accuracy		184	200	216	mV
$V_{\text{FB_DATA}}$	FB pin accuracy at Data = 26		14.3	20.3	26.3	mV
I_{FB}	FB pin bias current				0.1	μA
$R_{\text{DS(ON)}}$	NMOS on-resistance	$T_{\text{A}} = 25^{\circ}\text{C}$		0.6		Ω
V_{D}	Internal diode forward voltage	100mA		0.9		V
I_{LX}	LX pin leakage current			1		μA
I_{LIM}	Peak NMOS current limit			520		mA
$I_{\text{INRUSH-SU}}$	Peak Inductor Current During Startup	KTD2801, $V_{\text{IN}} = 3.6\text{V}$, 10 LEDs, $I_{\text{LED}} = 20\text{mA}$, $L = 10\mu\text{H}$, $C_{\text{OUT}} = 0.47\mu\text{F}$		400		mA
$I_{\text{INRUSH-OL}}$	Peak Inductor Current During Open-Load Condition	KTD2801, $V_{\text{IN}} = 3.6\text{V}$, $L = 10\mu\text{H}$, $C_{\text{OUT}} = 0.47\mu\text{F}$, $V_{\text{OVP}} = 36\text{V}$		450		mA
F_{SW}	Oscillator frequency			1.0		MHz
D_{max}	Maximum duty cycle		92	95		%
OVP	Over voltage threshold	Measured at VOUT pin	KTD2801		36	V
			KTD2801A		30.2	V
			KTD2801B		24.4	V

4. The KTD2801 is guaranteed to meet performance specifications over the -40°C to $+85^{\circ}\text{C}$ operating temperature range by design, characterization and correlation with statistical process controls.

Electrical Characteristics Continued⁵

Symbol	Description	Conditions	Min	Typ	Max	Units
Control						
V _{TH-L}	CTRL logic low threshold				0.4	V
V _{TH-H}	CTRL logic high threshold		1.4			V
R _{CTRL}	CTRL pull down resistor			300		kΩ
t _{off}	CTRL low pulse width to shutdown	CTRL high to low	2.5			ms
t _{EW_DET}	ExpressWire detection time ⁶		260			μs
t _{EW_DELAY}	ExpressWire detection delay time		140			μs
t _{EW_WIN}	ExpressWire detection window time		1			ms
t _{DS}	Start time of programming data		2			μs
t _{EOD_H}	End of data high time		350			μs
t _{EOD_L}	End of data low time		2		64	μs
t _{H_LB}	High time low bit	Logic 0	2		64	μs
t _{L_LB}	Low time low bit	Logic 0	2 x t _{H_LB}		128	μs
t _{H_HB}	High time high bit	Logic 1	2 x t _{L_HB}		128	μs
t _{L_HB}	Low time high bit	Logic 1	2		64	μs
f _{DIM}	Recommended PWM dimming frequency		5		100	kHz
D _{DIM}	PWM dimming duty cycle resolution	f _{DIM} = 20kHz	2			%
		f _{DIM} = 30kHz	3			%
T _{J-TH}	IC junction thermal shutdown threshold			150		°C
	IC junction thermal shutdown hysteresis			15		°C

5. The KTD2801 is guaranteed to meet performance specifications over the -40°C to +85°C operating temperature range by design, characterization and correlation with statistical process controls.

6. To select ExpressWire programming, the CTRL pin must be low for more than t_{EW_DET} during t_{EW_WIN}.

Typical Characteristics

$V_{IN} = 3.6V$, $L = 22\mu H$ (Coilcraft LPS4018-223), $C_{IN} = 10\mu F$, $C_{OUT} = 0.47\mu F$ with 8 LEDs in series at 20mA, $T_{AMB} = 25^{\circ}C$, unless otherwise specified.

Efficiency vs. Input Voltage

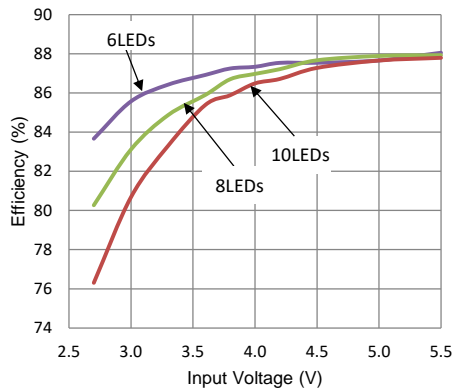

Efficiency vs. LED Current

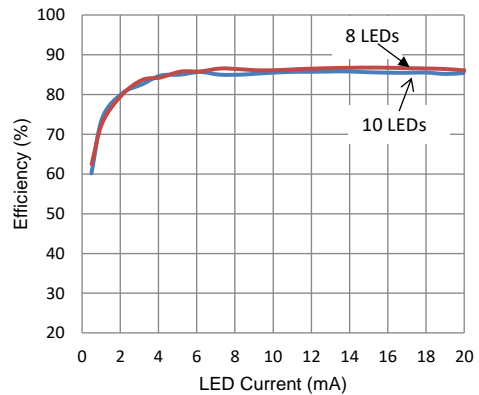

Efficiency vs. Input Voltage
($I_{out} = 40mA$, 2P6S LEDs)

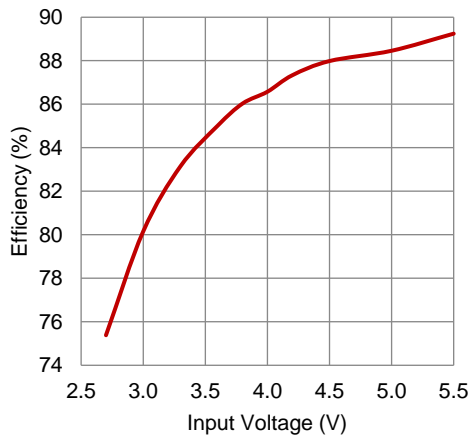

CTRL Logic Threshold Voltage

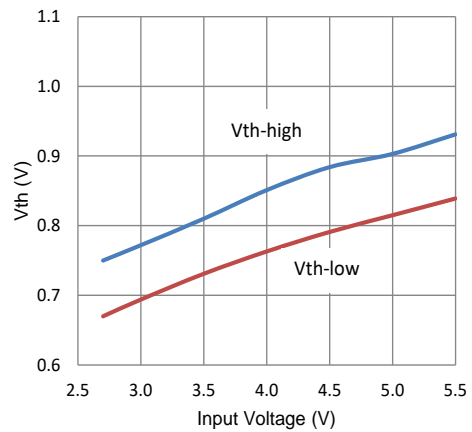

Quiescent Current (non-switching)

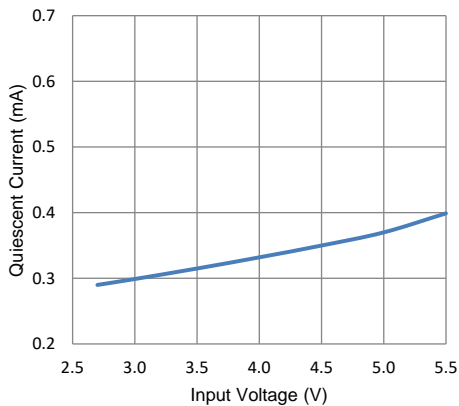

Operating Current (switching)

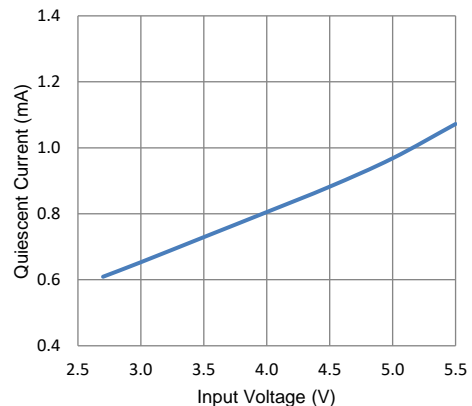

Typical Characteristics (continued)

$V_{IN} = 3.6V$, $L = 22\mu H$, $C_{IN} = 10\mu F$, $C_{OUT} = 0.47\mu F$ with 8 LEDs in series at 20mA, $T_{AMB} = 25^{\circ}C$, unless otherwise specified.

Soft Start Turn On

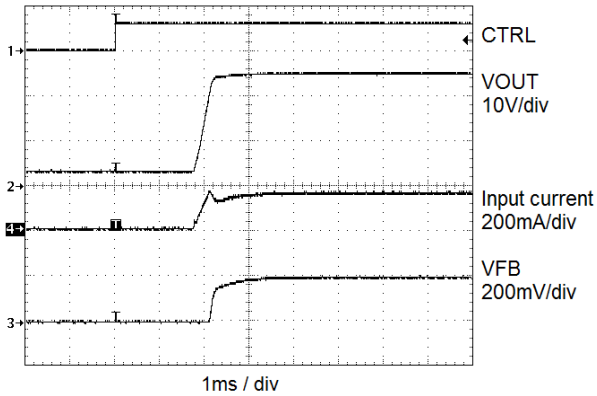

Turn Off

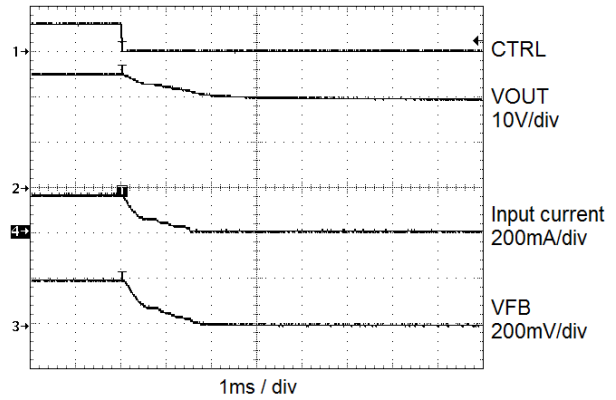

Steady State Switching

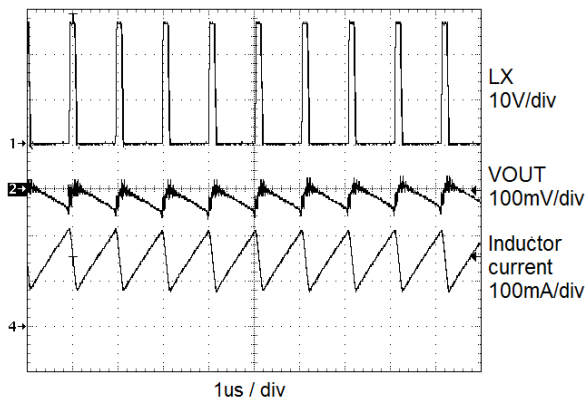

Turn On with LED Open (OVP)

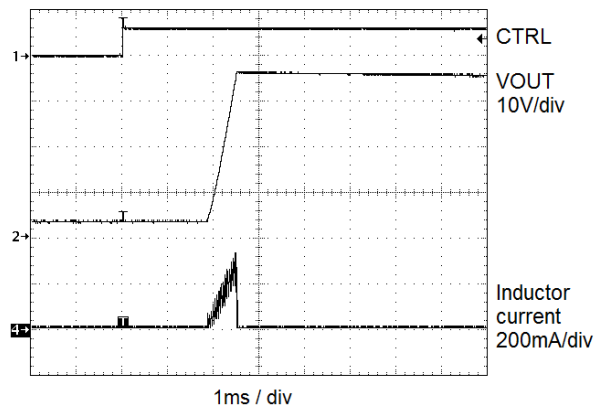

PWM Dimming (10kHz, 50% duty cycle)

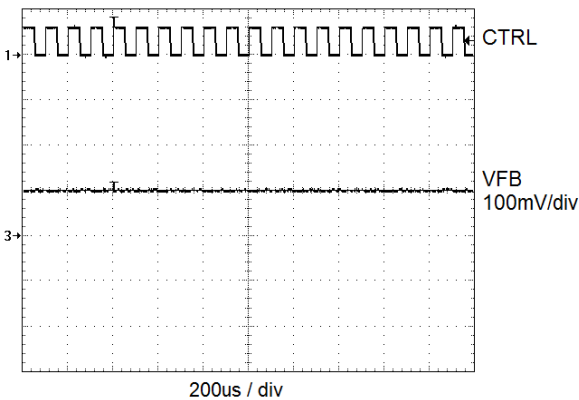

PWM Dimming Linearity (20kHz)

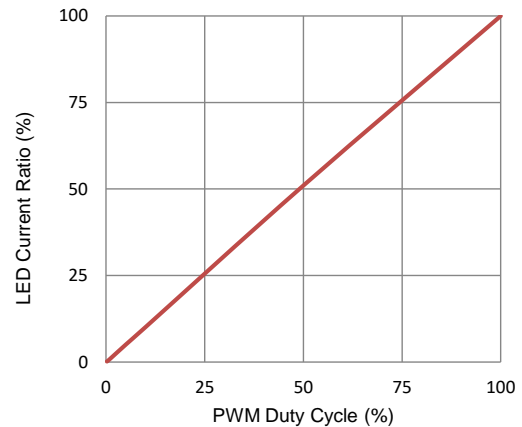

Typical Characteristics (continued)

$V_{IN} = 3.6V$, $L = 22\mu H$, $C_{IN} = 10\mu F$, $C_{OUT} = 0.47\mu F$ with 8 LEDs in series at 20mA, $T_{AMB} = 25^{\circ}C$, unless otherwise specified.

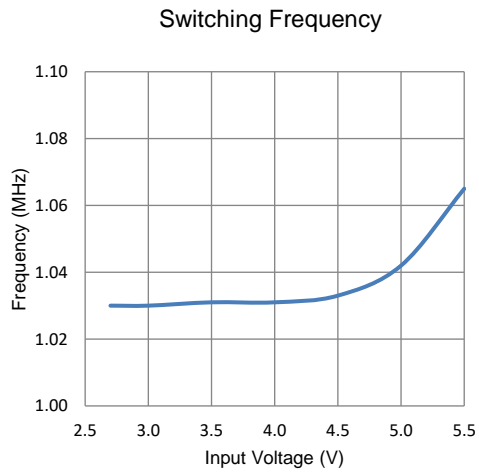

Functional Block Diagram

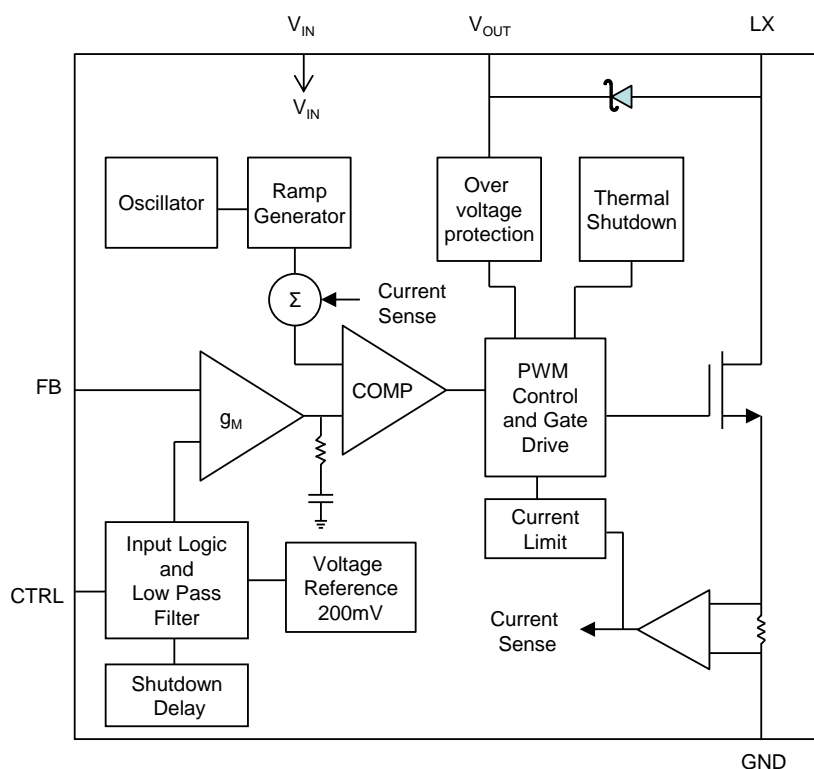

Functional Description

The KTD2801/A/B uses a constant-frequency current-mode boost converter architecture to control the LED current by regulating the feedback voltage. Please refer to the functional block diagram above for an explanation of the device operation. At the beginning of each switching cycle, the internal power MOSFET turns on between the LX node and GND. A slope compensation ramp is added to the output of the current sense amplifier and the result is fed into the positive input of the comparator (COMP). When this voltage goes above the output voltage of the error amplifier (g_M), the power MOSFET is turned off. The voltage at the output of the g_M block amplifies the difference between the reference voltage and the feedback voltage (FB), so that FB voltage can be regulated to the reference voltage.

The driver has built-in soft-start to limit the inrush current during startup and to limit the amount of overshoot on the output. Protection features in the KTD2801 include over-voltage protection (OVP), cycle-by-cycle current limit protection and thermal shutdown. OVP protects in the event where an LED fails open, which forces the feedback voltage to zero. This causes the boost converter to operate in maximum duty cycle mode, ramping up the output voltage. Switching will stop when the output reaches the OVP threshold. The OVP feature protects the IC from damaging itself by exceeding the voltage rating on LX/VOUT pins.

The control interface can be used for either PWM dimming or ExpressWire™ single-wire control. In ExpressWire mode, it accepts a data set into the CTRL pin to program the reference voltage. The data contains 8 bits, yielding 256 different current levels. In PWM dimming mode, PWM pulse is provided at CTRL pin to program the reference voltage according to the duty cycle of the PWM signal, so that the LED current is proportional to the PWM duty cycle. The simplest control method is accomplished by toggling CTRL between high and low to program the output current between I_{MAX} and 0mA. I_{MAX} is set by the resistor connected between FB and GND. Please see LED Maximum Current Setting section in this document to determine the proper resistor value.

The KTD2801 enters shutdown mode whenever the CTRL input pin is pulled low for more than 2.5ms.

Dimming Mode Selection

KTD2801 CTRL pin can be used for both PWM dimming and ExpressWire™ dimming. The dimming mode is selected when the IC is enabled. By default, the dimming mode is PWM dimming.

To use ExpressWire™ dimming, the first few pulses at CTRL pin should meet the following timing requirement shown in Figure 1.

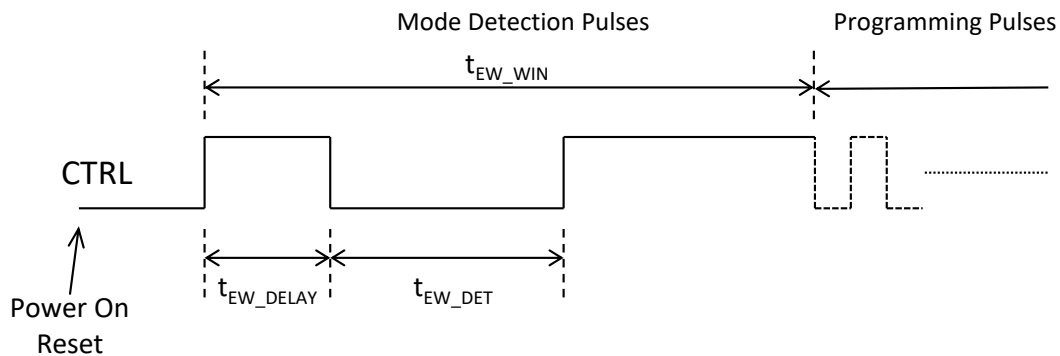

Figure 1. Dimming Mode Detection Pulses

1. After the IC is powered up, CTRL's 1st pulse high width (ExpressWire detection delay time) t_{EW_DELAY} should be greater than 140 μ s.
2. CTRL's 1st pulse low width (ExpressWire detection time) t_{EW_DET} should be greater than 260 μ s.
3. The programming pulses should be started within the ExpressWire detection window t_{EW_WIN} , which is 1ms. Otherwise the default setting or previous stored setting will be used to set the reference voltage.

Once CTRL's initial pulses meet the above timing requirement, the IC enters ExpressWire dimming mode. Then the user can continue to send programming pulses to adjust the reference voltage. Once ExpressWire dimming mode is selected, the IC can only change to PWM dimming mode by resetting the IC through CTRL pin or power on reset.

PWM Brightness Dimming Using CTRL Pin

After the IC is power reset, driving the CTRL pin continuously high will result in the FB voltage regulated at 200mV nominal. However, the CTRL pin allows a PWM signal (5kHz to 100kHz) to reduce this regulation voltage to control LED brightness dimming. The relationship between the duty cycle and FB voltage is given by the equation:

$$V_{FB} = DC \times 200mV$$

Where DC is the duty cycle of the PWM signal applied to CTRL pin, and 200mV is the default internal reference voltage.

KTD2801 internally applies the PWM input signal to the 200mV reference voltage which creates a 200mV (peak) signal with the same duty cycle as the PWM input signal. This is fed into an RC low pass filter which gives a DC voltage proportional to the duty cycle of the PWM signal. This voltage is connected to the error amplifier as the reference voltage for the FB pin regulation. This means the PWM signal controls the current via translation to a DC signal to accomplish analog dimming. The advantage of this method is the elimination of audible noise which can occur when the LED current is pulsed at the frequency of the PWM dimming signal. For best performance, the PWM dimming frequency should be in the range of 5kHz to 100kHz. The minimum frequency requirement is determined by the ExpressWire detection delay and detection time specification in described in Dimming Mode Selection.

ExpressWire™ Dimming Using CTRL Pin

The CTRL pin features a ExpressWire™ digital interface to program LED brightness. KTD2801 uses the ExpressWire protocol for digital dimming, which can program the FB voltage to 256 linear steps, shown in Table 1. The default step is full scale when the device is first enabled ($V_{FB} = 200$ mV). The programmed reference voltage is stored in an internal register. A power reset will bring the value back to the default setting; however, using CTRL to shut down the IC will not reset the internal register. Restarting the IC to ExpressWire dimming mode without setting the new FB voltage value will set the FB voltage back to the previous setting before the IC is shut down by CTRL pin.

Table 1. ExpressWire™ Interface – FB Voltage Programming Table

Code	V _{FB} (mV)	Code	V _{FB} (mV)	Code	V _{FB} (mV)	Code	V _{FB} (mV)	Code	V _{FB} (mV)	Code	V _{FB} (mV)	Code	V _{FB} (mV)	Code	V _{FB} (mV)
0	0.78	32	25.78	64	50.78	96	75.78	128	100.78	160	125.78	192	150.78	224	175.78
1	1.56	33	26.56	65	51.56	97	76.56	129	101.56	161	126.56	193	151.56	225	176.56
2	2.34	34	27.34	66	52.34	98	77.34	130	102.34	162	127.34	194	152.34	226	177.34
3	3.13	35	28.13	67	53.13	99	78.13	131	103.13	163	128.13	195	153.13	227	178.13
4	3.91	36	28.91	68	53.91	100	78.91	132	103.91	164	128.91	196	153.91	228	178.91
5	4.69	37	29.69	69	54.69	101	79.69	133	104.69	165	129.69	197	154.69	229	179.69
6	5.47	38	30.47	70	55.47	102	80.47	134	105.47	166	130.47	198	155.47	230	180.47
7	6.25	39	31.25	71	56.25	103	81.25	135	106.25	167	131.25	199	156.25	231	181.25
8	7.03	40	32.03	72	57.03	104	82.03	136	107.03	168	132.03	200	157.03	232	182.03
9	7.81	41	32.81	73	57.81	105	82.81	137	107.81	169	132.81	201	157.81	233	182.81
10	8.59	42	33.59	74	58.59	106	83.59	138	108.59	170	133.59	202	158.59	234	183.59
11	9.38	43	34.38	75	59.38	107	84.38	139	109.38	171	134.38	203	159.38	235	184.38
12	10.16	44	35.16	76	60.16	108	85.16	140	110.16	172	135.16	204	160.16	236	185.16
13	10.94	45	35.94	77	60.94	109	85.94	141	110.94	173	135.94	205	160.94	237	185.94
14	11.72	46	36.72	78	61.72	110	86.72	142	111.72	174	136.72	206	161.72	238	186.72
15	12.50	47	37.50	79	62.50	111	87.50	143	112.50	175	137.50	207	162.50	239	187.50
16	13.28	48	38.28	80	63.28	112	88.28	144	113.28	176	138.28	208	163.28	240	188.28
17	14.06	49	39.06	81	64.06	113	89.06	145	114.06	177	139.06	209	164.06	241	189.06
18	14.84	50	39.84	82	64.84	114	89.84	146	114.84	178	139.84	210	164.84	242	189.84
19	15.63	51	40.63	83	65.63	115	90.63	147	115.63	179	140.63	211	165.63	243	190.63
20	16.41	52	41.41	84	66.41	116	91.41	148	116.41	180	141.41	212	166.41	244	191.41
21	17.19	53	42.19	85	67.19	117	92.19	149	117.19	181	142.19	213	167.19	245	192.19
22	17.97	54	42.97	86	67.97	118	92.97	150	117.97	182	142.97	214	167.97	246	192.97
23	18.75	55	43.75	87	68.75	119	93.75	151	118.75	183	143.75	215	168.75	247	193.75
24	19.53	56	44.53	88	69.53	120	94.53	152	119.53	184	144.53	216	169.53	248	194.53
25	20.31	57	45.31	89	70.31	121	95.31	153	120.31	185	145.31	217	170.31	249	195.31
26	21.09	58	46.09	90	71.09	122	96.09	154	121.09	186	146.09	218	171.09	250	196.09
27	21.88	59	46.88	91	71.88	123	96.88	155	121.88	187	146.88	219	171.88	251	196.88
28	22.66	60	47.66	92	72.66	124	97.66	156	122.66	188	147.66	220	172.66	252	197.66
29	23.44	61	48.44	93	73.44	125	98.44	157	123.44	189	148.44	221	173.44	253	198.44
30	24.22	62	49.22	94	74.22	126	99.22	158	124.22	190	149.22	222	174.22	254	199.22
31	25.00	63	50.00	95	75.00	127	100.00	159	125.00	191	150.00	223	175.00	255	200.00

The ExpressWire™ protocol consists of 8 data bits in conjunction with DS (Data Start) and EOD (End Of Data) for acknowledge condition of data bit.

The protocol starts from DS time for data input and ends with EOD time to recognize the end of data. Figure 2 shows the ExpressWire™ interface protocol.

The Low Bit(0) and High Bit(1) is based on a time detection algorithms between t_{LOW} and t_{HIGH} .

The t_{L_LB} is low time of the Low Bit(0) and the t_{H_LB} is high time of the Low Bit(0).

The t_{L_HB} is low time of the High Bit(1) and the t_{H_HB} is high time of the High Bit(1).

It can be simplified to :

Low Bit(0) : $t_{H_LB} < t_{L_LB}$, but with t_{L_LB} at least $2x t_{H_LB}$ (see Figure 2)

High Bit(1) : $t_{H_HB} > t_{L_HB}$, but with t_{H_HB} at least $2x t_{L_HB}$ (see Figure 2)

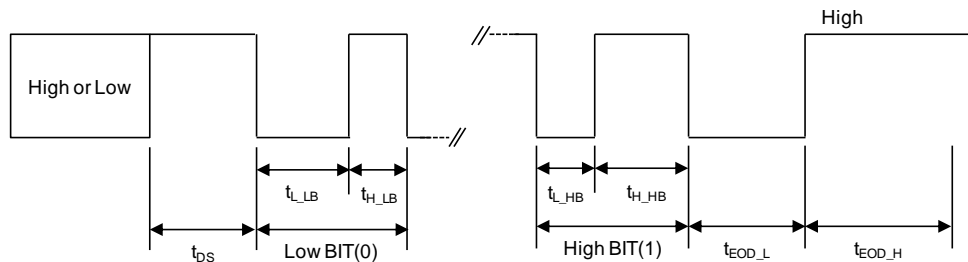

Figure 2. ExpressWire™ Interface – bit Coding Time

ExpressWire™ Interface Protocol

Output control and programmability is achieved by using the CTRL pin. Refer to the figures below for further explanation of the interface protocol.

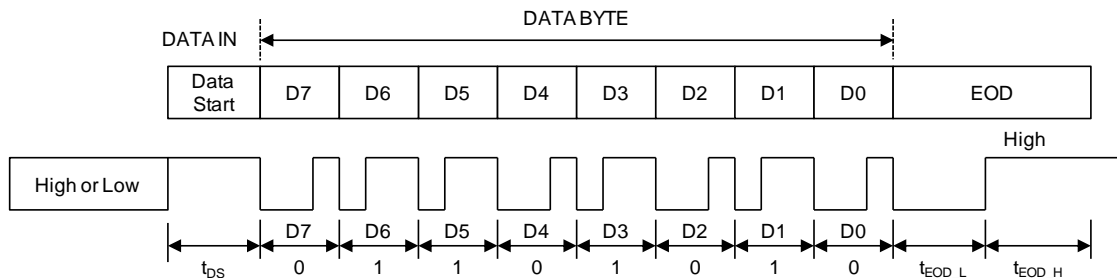

Figure 3. ExpressWire™ Interface Protocol Overview

Table 2. CTRL Data Bit Table

IC PIN	Byte	Bit Number	Name	Direction	Description
CTRL	Data Byte	7 (MSB)	D7	Input	DATA BIT 7
		6	D6		DATA BIT 6
		5	D5		DATA BIT 5
		4	D4		DATA BIT 4
		3	D3		DATA BIT 3
		2	D2		DATA BIT 2
		1	D1		DATA BIT 1
		0 (LSB)	D0		DATA BIT 0

Table 3. CTRL – Disable Control

IC PIN	Control	Description
CTRL	Low (> 2.5ms)	- Device Shutdown

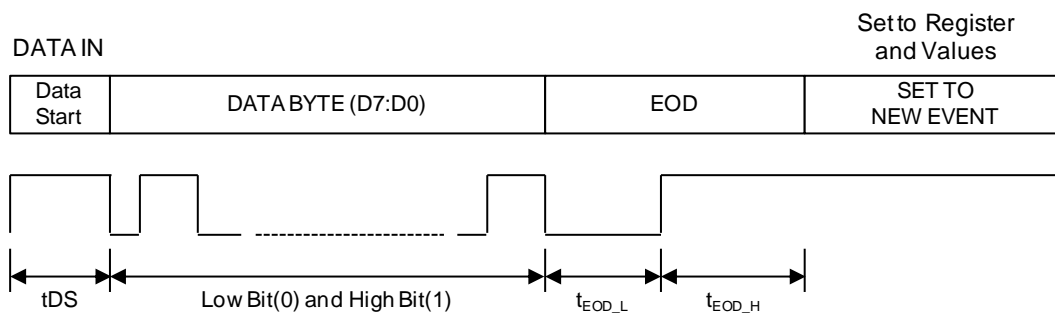

Figure 4. ExpressWire™ Interface – Set to Data Register Overview

LED Maximum Current Setting

LED maximum current setting, I_{MAX}, is determined by the feedback resistor R1 (connected between FB and GND pins). The feedback voltage is internally set at 200mV at 100% dimming setting. The LED current is programmed according to the formula $I_{MAX} = 200mV / R1$. For accurate LED current settings, precision 1% resistors are recommended. The formula and table for R1 selection are shown below.

$$R1 = 200mV / I_{MAX}$$

Table 4. Current Setting Resistor (1%Values)

R1 (Ω) 1% Values	I _{MAX} Current (mA)
200.0	1
40.2	5
20.0	10
13.3	15
10.0	20
6.7	30
2.0	100

Application Information

Inductor Selection

A 10 μ H or 22 μ H inductor is recommended for the typical application. If high efficiency is a critical requirement, a low DCR inductor should be selected. The inductor's saturation current rating should also exceed the peak input current.

Table 5. Recommended Inductor Part Numbers

Inductor Part Number	Value (μ H)	DCR (Ω)	Saturation Current (A)	Dimensions (mm)	Manufacturer
LPS4018-103ML	10	0.20 max	1.3	4 x 4 x 1.8	Coilcraft
LPS4018-223ML	22	0.36 max	0.74	4 x 4 x 1.8	Coilcraft
VLF4012AT-100MR79	10	0.35	0.79	3.5 x 3.7 x 1.2	TDK
VLF4014AT-100MR90	10	0.26	0.9	3.5 x 3.7 x 1.4	TDK
VLCF5020T-100MR87	10	0.182 max	0.87	5 x 5 x 2.0	TDK
VLCF5020T-220MR58	22	0.373 max	0.58	5 x 5 x 2.0	TDK

Capacitor Selection

Small size X5R or X7R ceramic capacitors are recommended for the KTD2801 application. A 10 μ F input capacitor and a 0.1 μ F to 0.47 μ F output capacitor are suggested for up to 10-series LED applications. To prevent too much inrush current during LED open load condition, output capacitor values larger than 0.47 μ F are not allowed for 10-series LED applications.

Table 6. Recommended Ceramic Capacitor Vendors

Manufacturer	Website
Murata	www.murata.com
AVX	www.avx.com
Taiyo Yuden	www.t-yuden.com

Optional Diode Selection

The KTD2801 has an integrated diode connected between LX and Vout. This internal diode provides excellent performance for up to 10-LED application; however, if more LEDs or higher efficiency is desired, an external low V_F diode can be placed in parallel with the internal diode. In this configuration, a Schottky diode is recommended in KTD2801 applications because of its low forward voltage drop and fast reverse recovery time. The current rating of the Schottky diode should exceed the peak current of the boost converter. The voltage rating should also exceed the target output voltage.

Table 7. Recommended Schottky Diode Part Numbers

Application	Schottky Diode Part Number	Forward Voltage (V)	Forward Current (mA)	Reverse Voltage (V)	Manufacturer
Up to 10 series LEDs	PMEG4005EJ	0.42	500	40	NXP
Up to 10 series LEDs	PMEG4010EJ	0.54	1000	40	NXP
4/5/6-series LEDs, 24V OVP	B130	0.52	1000	30	Vishay
8/10-series LEDs, 36V OVP	B150	0.75	1000	50	Vishay

Typical Application Circuits

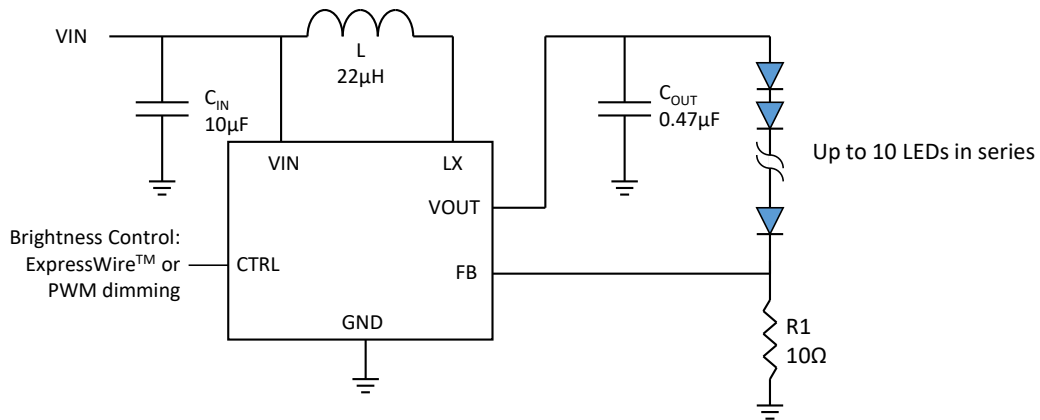

Figure 5. Application Circuit for 10 LEDs in Series at 20mA

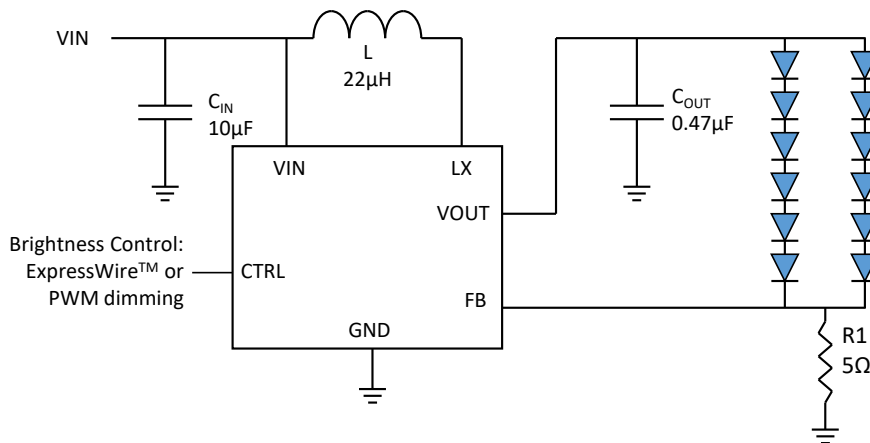

Figure 6. Application Circuit for 2P6S LEDs at 40mA Output Current

Layout Recommendation

PCB layout is very important for high frequency switching regulators in order to keep the loop stable and minimize noise. The input capacitor CIN should be very close to the IC to get the best decoupling. The traces to the inductor L and output capacitor COUT should be kept as short as possible to minimize noise and ringing. FB is a sensitive node and it should be kept separate from the LX switching node in the PCB layout.

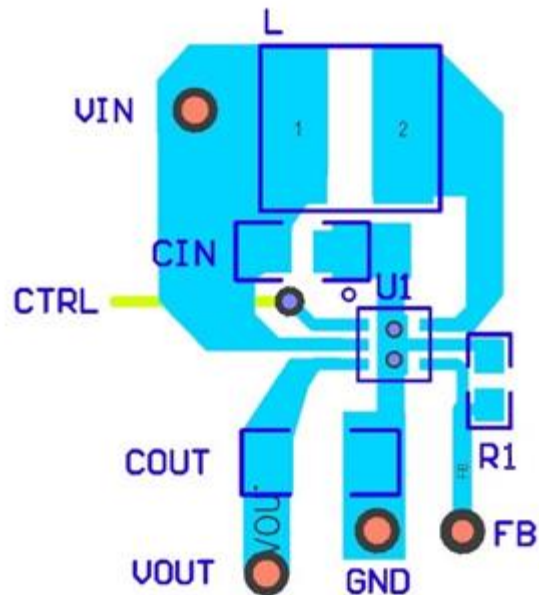
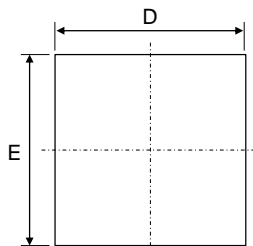

Figure 7. Recommended PCB Layout for TDFN22-6 Package

Packaging Information

TDFN22-6

Top View



Bottom View

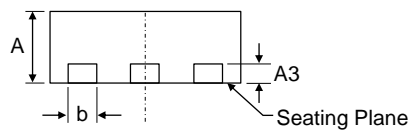
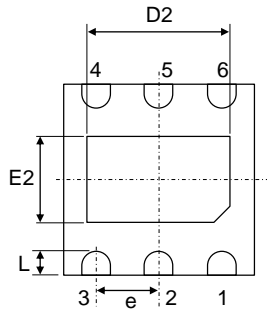

Side View

Dimension	mm		
	Min.	Typ.	Max.
A	0.70	0.75	0.80
A3	0.2BSC		
b	0.25	0.30	0.35
D	1.90	2.00	2.10
D2	1.40	1.50	1.60
E	1.90	2.00	2.10
E2	0.80	0.90	1.00
e	0.65BSC		
L	0.20	0.25	0.30

Recommended Footprint

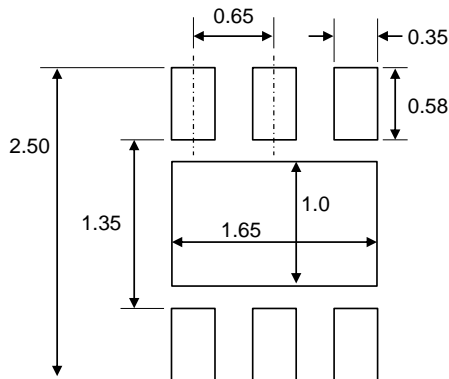

* Dimensions are in millimeters.

TSOT23-6

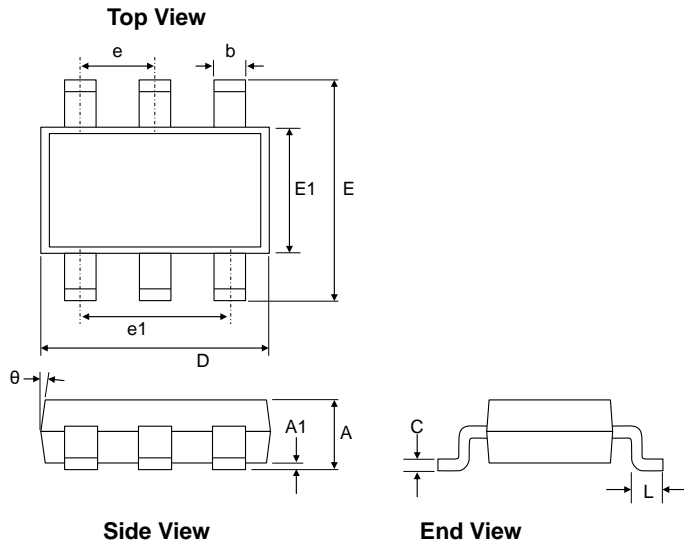

Dimension	mm		
	Min.	Typ.	Max.
A	0.60	0.85	1.10
A1	0.00	0.05	0.10
b	0.30	0.40	0.50
c	0.10	0.15	0.20
D	2.70	2.90	3.10
E	2.60	2.80	3.00
E1	1.40	1.60	1.80
e	0.95BSC		
e1	1.9BSC		
L	0.30		0.60
θ	4°		12°

Recommended Footprint

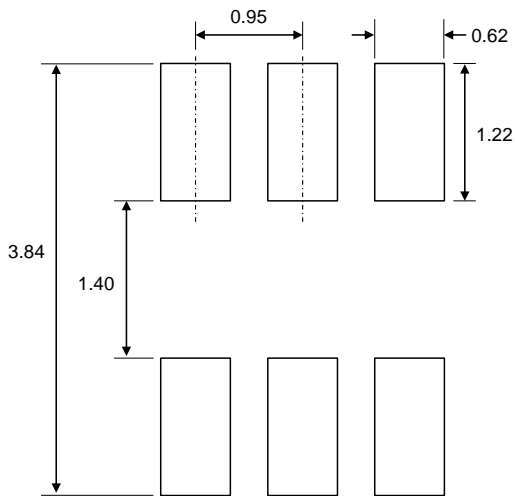

* Dimensions are in millimeters.

Kinetic Technologies cannot assume responsibility for use of any circuitry other than circuitry entirely embodied in a Kinetic Technologies product. No intellectual property or circuit patent licenses are implied. Kinetic Technologies reserves the right to change the circuitry and specifications without notice at any time.

Looking for pricing, stock, or lifecycle information?

Click below to explore more details on WIN SOURCE:

 [View KTD2801ECD-TR on WIN SOURCE](#)

 [Kinetic Information](#)

Optimize Your Supply Chain with WIN SOURCE Solutions

-  Global Sourcing Solution
-  Obsolete Management
-  Cost Control Management
-  Shortage Management
-  Alternative Solution
-  Excess Inventory Management