

X79000, X79001, X79002

NV DAC with Selectable Output Range and Memory

FN8147
Rev 0.00
March 17, 2005

FEATURES

- 12-Bit Resolution
- Selectable full scale and zero scale voltages
- Optional External full scale and zero scale references
- Programmable, non-volatile DAC initial value register
- Optional UP/DOWN interface
- Guaranteed Monotonic Operation, <0.5LSB DNL
- Buffered Output Option
- Integrated Voltage Reference Option
- Voltage Reference Output (1.21V) Option
- 6 μ s settling time, full scale
- SPI interface, 5MHz
- Up to 5 slave Address Pins
- Power-up recall and ready output
- 56 Bytes of general purpose EEPROM
- Asynchronous clear pin and control bit
- $V_{CC} = 5V \pm 10\%$
- 20-lead TSSOP
- NV DAC

DESCRIPTION

The X79000 is a family of Single Channel Non-Volatile (NV) Digital-to-Analog Converters with integrated voltage reference, configurable output buffer, general purpose EEPROM, and selectable full scale and zero offset voltages.

The X79000 series implements an SPI serial bus interface with slave address identification allowing up to 32 devices on some options. The full scale and zero scale voltages and the DAC initial value register can be set via the SPI bus interface. Optional pins are provided for Up/Down style interface allowing for increment and decrement of the DAC register in 1, 4, or 16 steps at a time.

A Power-on Recall circuit is implemented to keep the DAC output at high impedance on power-up and to load an initial user defined value from non-volatile memory. A power-up ready signal is provided to alert the system to begin operations.

Additional general purpose non-volatile memory (56 Bytes) is provided for curve-fit profile setting, signal conditioning parameters, or device and system identification.

X79000 FUNCTIONAL DIAGRAM

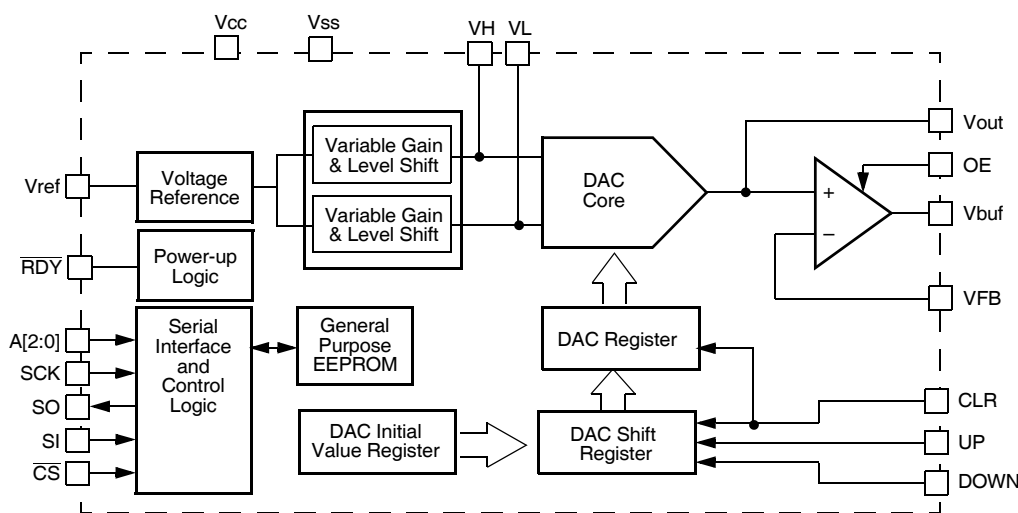

X79001 / X79002 FUNCTIONAL DIAGRAM

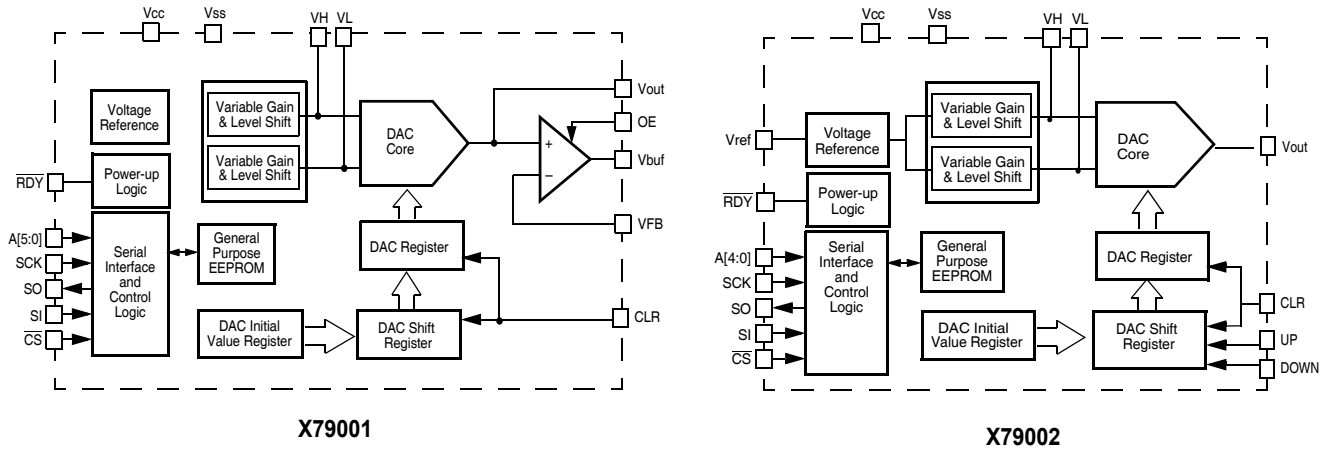

PIN CONFIGURATION

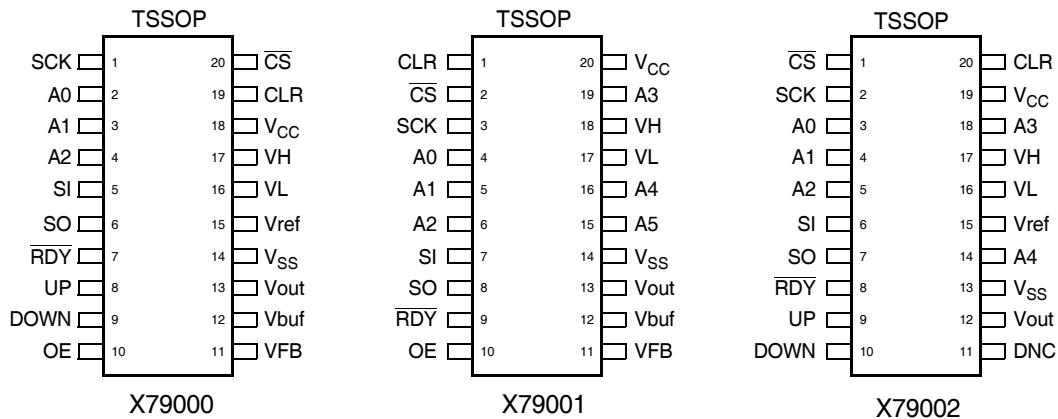

DNC = Do Not Connect

ORDERING INFORMATION

Device	Features						
	Voltage References			Voltage Outputs	DAC Control		System Control
	Voltage Ref Output Pin (Vref)	Full Scale Voltage Input/Output (VH)	Zero Scale Voltage Input/Output (VL)	Buffered Out (Vbuf) and Buffer Feedback (VFB) with Enable (OE)	Increment/Decrement (UP, DOWN)	Slave Address Pins	Power Ready (RDY)
X79000V20I	Y	Y	Y	Y	Y	A0, A1, A2	Y
X79001V20I	N	Y	Y	Y	N	A0, A1, A2, A3, A4, A5	Y
X79002V20I	Y	Y	Y	N	Y	A0, A1, A2, A3, A4	Y

Notes: Y = Yes, N = No

*All options are for 12-bit resolution, industrial temperature operating range, and a 20-pin TSSOP package.

PIN DESCRIPTIONS

Pin Name	Pin Description
\overline{CS}	SPI Chip Select. CMOS Input Pin. Active low.
SCK	SPI Clock. CMOS Input Pin, with hysteresis.
SI	SPI Serial Data. CMOS Input Pin, with hysteresis.
SO	SPI Serial Data Output Pin. CMOS levels with high impedance state.
\overline{RDY}	Power-Up "Ready" Indicator Output Pin. Active low. Open drain output.
CLR	Clear DAC Volatile Register Input Pin. Active high. CMOS Input Pin with hysteresis. On-chip pulldown.
A5, A4, A3, A2, A1, A0	SPI Address Input pins. CMOS Input Pins. On-chip pulldowns.
OE	Buffer Output Enable Input Pin. Active high. CMOS Input Pin with hysteresis. On-chip pulldown.
UP	UP Input pin of the UP/DOWN interface. CMOS Input Pin with deglitching filter. On-chip pulldown.
DOWN	DOWN Input pin of the UP/DOWN interface. CMOS Input Pin with deglitching filter. On-chip pulldown.
V _{CC}	Power Supply Pin.
V _{SS}	Ground Pin.
Vout	Unbuffered DAC Output Pin.
Vbuf	Buffered DAC Output Pin.
VFB	Feedback Pin for Buffer Stage.
Vref	Bandgap Voltage Output Pin.
VH	Full Scale Voltage Input or Output Pin.
VL	Zero Scale Voltage Input or Output Pin.
DNC	Do Not Connect

ABSOLUTE MAXIMUM RATINGS

All voltages are referred to Vss

Temperature under bias	-40°C to 85°C
Storage temperature	-65°C to +150°C
Voltage on every pin except Vcc	-0.5V to +7V
Voltage on Vcc Pin	-0.5V to 6V
D.C. Output Current at pins SO and $\overline{\text{RDY}}$	5 mA
D.C. Output Current at pins VL, VH, VFB, Vout and Vref	-0.50 to 1 mA
VBUF output short circuit duration.....	10 seconds
Lead temperature (soldering, 10 seconds).....	300°C

COMMENT

Stresses above those listed under “Absolute Maximum Ratings” may cause permanent damage to the device. This is a stress rating only; functional operation of the device (at these or an other conditions above those listed in the operational sections of this specification) is not implied. Exposure to absolute maximum rating conditions for extended periods may affect device reliability.

RECOMMENDED OPERATING CONDITIONS

Parameter	Min.	Max.	Units
Temperature	-40	+85	°C
Voltage on Vcc Pin	4.5	5.5	V
Voltage on any other Pin	-0.3	Vcc +0.3	V

ELECTRICAL CHARACTERISTICS

(Unless otherwise specified, all typical values are for 25°C ambient temperature and 5V at pin Vcc. Maximum and minimum specifications are over the recommended operating conditions. All voltages are referred to the voltage at pin Vss. All bits in control registers are “0”. SPI interface in “standby” (see notes 1 and 2 on page 6). Output pins unloaded. Input pins floating. DAC input is 000hex.)

Parameter	Min	Typ	Max	Units	Notes
Buffered DAC and Reference					
Resolution		12		bit	
INL			±10	LSB	(1)(2)(3) VL = 0.151V, VH = 3.025V
DNL	-0.5		0.5	LSB	
Total Offset Error			12	mV	(1)(2)(4) VL = 0.151V, VH = 3.025V
Total Fullscale Error			22	mV	
Total Offset Error Drift		50		ppm/°C	(1)(2)(4) VL = 0.151V, VH = 3.025V
Total Fullscale Error Drift		50		ppm/°C	
Settling time to 1 LSB		2	10	µs	Step size ≤ 100mV (2)(5)
		6	30	µs	Step size up to full scale (2)(5)
Buffer Only					
Output Buffer Offset	-6		6	mV	150mV < Vout < VCC - 150mV
Output Buffer Offset Drift	-20		20	µV/°C	(5)
DC PSRR	-1.5		+1.5	mV/V	(5)
Vbuf output slew rate	0.2			V/µs	
Output Buffer 3dB Bandwidth	300	1000		kHz	150mV < (V(VFB) = V(Vbuf)) < VCC - 150mV (5)
Digital feed through		10		nV•sec	(6)
Output load regulation	-1		1	mV/mA	140mV ≤ V(Vbuf) ≤ VCC-140mV I(Vbuf) = ±1mA
Short circuit current @ Vbuf		50		mA	V(Vbuf) = VCC or 0V
Capacitive Loading Stability	100			pF	Rload ≥ 2kΩ (5)

ELECTRICAL CHARACTERISTICS (continued)

Symbol	Parameter	Min	Typ	Max	Unit	Test Conditions / Notes
Reference						
V _{refout}	Output Voltage at V _{Ref} at 25°C	1.20	1.21	1.22	V	-20μA ≤ I(V _{Ref}) ≤ 0, V _{ref} as an output
TC _{oref}	Temperature coefficient of V _{Ref} output voltage		50		ppm/°C	(5)
R _{VHVL}	Resistance between VL and VH	9	11.4	14	kΩ	VH & VL external
Digital Interface						
t _{OEVALID}	OE rising edge to output valid delay			100	μs	
t _{OEDIS}	OE falling edge to high impedance output delay			100	μs	
C _{out}	SO and $\overline{\text{RDY}}$ pin capacitance			10	pF	Voltage at pin of 0V or V _{cc} . 1 MHz signal. (4)
C _{in}	CLR, $\overline{\text{CS}}$, SCK, A0, A1, A2, A3, A4, A5, SI, UP, DOWN, OE pin capacitance			8	pF	
I _{PLDN}	On-chip pull down current at A0, A1, A2, A3, A4, A5, UP, DOWN, and CLR	0	1	20	μA	Voltage at the pin between 0V and V _{cc}
V _{ILSPI}	$\overline{\text{CS}}$, SCK and SI input Low voltage	-0.8		0.2 x V _{cc}	V	
V _{IHSPI}	$\overline{\text{CS}}$, SCK and SI input High voltage	0.8 x V _{cc}		V _{cc} + 0.3	V	
I _{INSPI}	$\overline{\text{CS}}$, CLK and SI input current	-1		10	μA	Voltage at the pin between 0V and V _{cc}
V _{OHSO}	SO output High voltage	V _{cc} -0.4		V _{cc}	V	I(SO) = -2mA
V _{OLSO}	SO Output Low Voltage	0		0.4	V	I(SO) = 2mA
I _{OZSO}	SO output High impedance current	-20		+20	μA	V(SO) between 0 and V _{cc}
V _{OLSO}	$\overline{\text{RDY}}$ and SO output Low voltage	0		0.4	V	I(SO) or I($\overline{\text{RDY}}$) = 2 mA
I _{OHRDY}	$\overline{\text{RDY}}$ output High current	0		100	μA	V($\overline{\text{RDY}}$) = V _{cc}
V _{ILCMOS}	CLR, OE, UP, DOWN, A0, A1, A2, A3, A4, and A5 input Low voltage	-0.3		0.2 x V _{cc}	V	
V _{IHCMOS}	CLR, OE, UP, DOWN, A0, A1, and A2 input High voltage	0.8 x V _{cc}		V _{cc} + 0.3	V	
V _{HYST}	$\overline{\text{CS}}$, SI, SCK, CLR, OE, UP and DOWN input hysteresis	0.5			V	(5)
Power Requirements						
I _{ccstby}	Standby current into V _{cc} pin			2.5	mA	V(SCK) = V(SI) = 0 V, V($\overline{\text{CS}}$) = V _{cc}
I _{ccfull}	Full operation current into V _{cc} pin			3	mA	2-wire interface reading from memory, 2.5 MHz clock at SCK, V(OE) = V _{cc} , VFB = V _{BUF} (2)
I _{ccwrite}	Nonvolatile Write current into V _{cc} pin			3	mA	Average during internal non-volatile write cycle

Symbol	Parameter	Min	Typ	Max	Unit	Test Conditions / Notes
V _{POR}	Power-on reset threshold voltage	1.5		2.8	V	
V _{RDY}	RDY indicator minimum voltage	2.6		2.8	V	See figure 1.
T _{RDY}	RDY indicator delay	100		6000	μs	2kΩ and 100pF between Vcc and RDY ⁽⁴⁾

- Notes: 1. INL, DNL, Offset Error and Full Scale error measured at V_{buf} with VFB connected to V_{buf}.
 2. The V_L and V_H levels are set using the configuration register according to the following table:

Address	VH2	VH1	VH0	VL2	VL1	VL0	Count 8	Count 10
3Ch	1	0	1	0	0	1	X	X

X = don't care

This setting corresponds to the nominal values of V_H = 3.025V and V_L = 0.151V

3. INL is measured at the maximum range of (V_H-V_L). INL varies inversely with the range of (V_H-V_L). DNL increases at lower (V_H-V_L) ranges but the DAC retains monotonicity.
 4. Total offset error scales with V_L according to (1% x V_L) + 10mV and total full scale error scales with V_H according to (1% x V_H) + 10mV
 5. Guaranteed by characterization, not 100% tested.
 6. f_{SCK} = 5MHz, using SPI interface test conditions on pg. 8.

ENDURANCE AND DATA RETENTION (V_{CC} = 5V ±10%, T_A = Full Operating Temperature Range)

Parameter		
Minimum endurance	100,000	Data changes per bit
Data retention	10	Years

FIGURE 1. RDY PIN TIMING

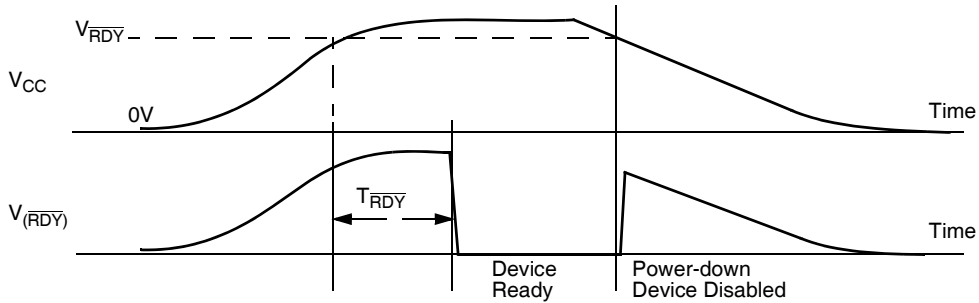

SYMBOL TABLE

WAVEFORM	INPUTS	OUTPUTS
	Must be steady	Will be steady
	May change from Low to High	Will change from Low to High
	May change from High to Low	Will change from High to Low
	Don't Care: Changes Allowed	Changing: State Not Known
	N/A	Center Line is High Impedance

V_{buf} OUTPUT ENABLE TIMING

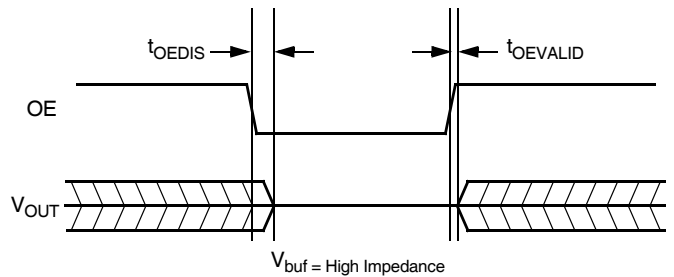

UP/DOWN INTERFACE TIMING

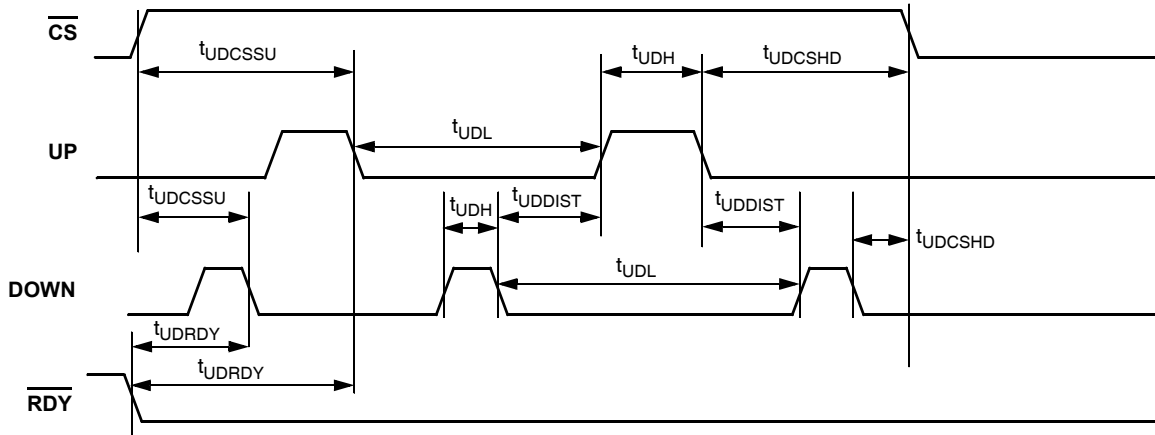

Symbol	Parameter	Min	Max	Unit
t_{UDCSSU}	\overline{CS} setup time with respect to UP or DOWN	1		μs
t_{UDCSDH}	\overline{CS} hold time with respect to UP or DOWN	1		μs
t_{UDH}	UP or DOWN pulsewidth HIGH	1		μs
t_{UDL}	UP or DOWN pulsewidth LOW	1		μs
t_{UDDIST}	UP or DOWN Distance	1		μs
$t_{UDRDY}^{(1)}$	UP or DOWN setup time with respect to \overline{RDY}	1		μs
$t_{UDRF}^{(1)}$	UP or DOWN rise or fall times		1	μs

DEVICE ADDRESS PINS TIMING

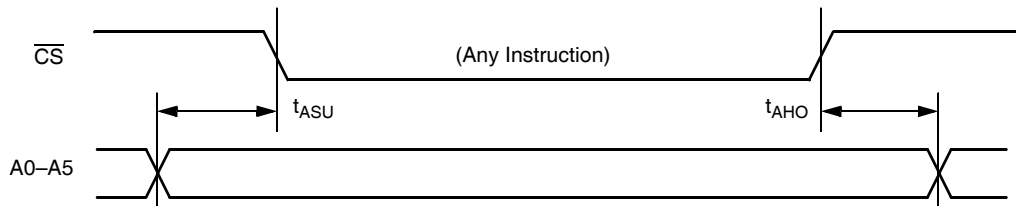

ADDRESS PINS TIMING

Symbol	Parameter	Min	Max	Unit
t_{ASU}	A0, A1, A2, A3, A4, A5 setup time	1		μs
t_{AHO}	A0, A1, A2, A3, A4, A5 hold time	1		μs

SPI INPUT TIMING

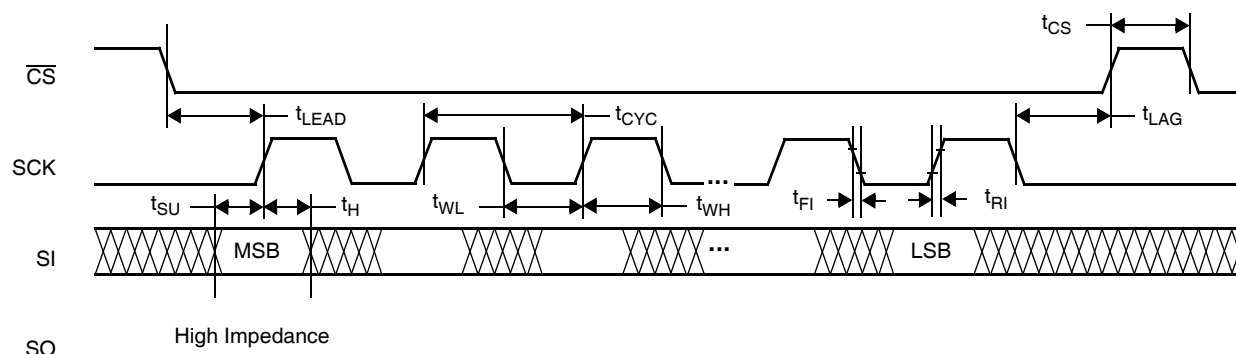

SPI INTERFACE TEST CONDITIONS

Input Pulse Levels	10% to 90% of V_{CC}
Input Rise and Fall times, between 10% and 90%	10ns
Input and Output Timing Threshold Level	1.4V
External Load at pin SO	2.6k Ω to V_{CC} , 3.03k Ω to V_{SS} , and 10pF to V_{SS}

SERIAL INPUT TIMING

Symbol	Parameter	Min.	Max.	Unit
f_{SCK}	Clock Frequency		5	MHz
t_{CYC}	Cycle Time	200		ns
t_{WH}	Clock HIGH Time	80		ns
t_{WL}	Clock LOW Time	80		ns
t_{LEAD}	\overline{CS} Lead Time	100		ns
t_{LAG}	\overline{CS} Lag Time	100		ns
t_{SU}	Data Setup Time	20		ns
t_H	Data Hold Time	20		ns
$t_{RI}^{(1)}$	Input Rise Time		20	ns
$t_{FI}^{(1)}$	Input Fall Time		20	ns
t_{CS}	\overline{CS} Deselect Time	100		ns
$t_{WC}^{(2)}$	Non-volatile Write Cycle Time		10	ms

- Notes:
1. These parameters are periodically sampled and not 100% tested.
 2. t_{WC} is the time from the rising edge of \overline{CS} after a valid nonvolatile write sequence, to the end of the self-timed internal non-volatile write cycle. It is the minimum cycle time to be allowed for any non-volatile write cycle by the user, unless the "WIP" bit is used to check for the end of the write cycle.

SPI OUTPUT TIMING

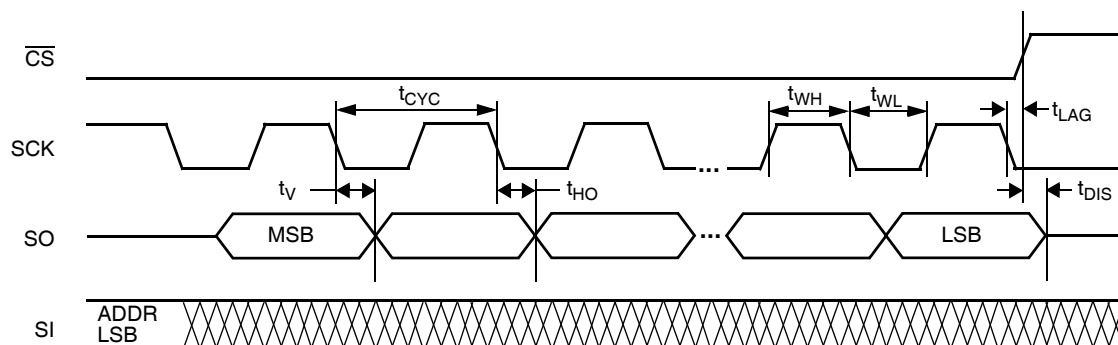

SERIAL OUTPUT TIMING

Symbol	Parameter	Min.	Max.	Unit
f_{SCK}	Clock Frequency		5	MHz
t_{CYC}	Cycle Time	200		ns
$t_{DIS}^{(1)}$	Output Disable Time		50	ns
$t_v^{(1)}$	Output Valid from Clock Low		80	ns
t_{HO}	Output Hold Time	0		ns
$t_{RO}^{(1)}$	Output Rise Time		25	ns
$t_{FO}^{(1)}$	Output Fall Time		25	ns

Note: 1. These parameters are periodically sampled and not 100% tested.

DETAILED OPERATION

The X79000 is a versatile 12-bit DAC which allows non-volatile control over the output range, and consequently over the resolution of the voltage output.

There are two different ways to adjust the output voltage of the device. One way is to use the SPI serial bus to perform a Write command to set the output. This operation is useful for open loop applications where simple adjustment of a DC voltage value is desired. The X79000 offers the unique option of optimizing the resolution for a given application.

The other way uses the UP/DOWN interface to increment or decrement the output to converge to a specific value. This operation is useful for closed loop systems which can step the output to the desired position, then disable the interface to hold that value. Alternatively, the system could continue to increment or decrement the DAC to update its output control to compensate for system temperature drifts or other long term variations.

Output Voltage Span Control

The output voltage span is controlled by 6 MSB's of the Configuration Register, which is at location 3Ch:

VH2	VH1	VH0	Value	VL2	VL1	VL0	Value
0	0	0	external	0	0	0	external
0	0	1	605mV	0	0	1	151mV
0	1	0	1.21V	0	1	0	605mV
0	1	1	1.815V	0	1	1	1.21V
1	0	0	2.42V	1	0	0	1.815V
1	0	1	3.025V	1	0	1	2.42V

The 3 MSB's control the VH span from 0.605V to 3.025V, and the next three bits control the VL span from 0.151V to 2.42V. Note that the selection of a value for VH can never be lower than that for VL. Regardless of the range selection, the specified linearity is guaranteed. Thus, if a particular application requires operation from, say, 1.9V to 2.4V, then the X79000 can be set for the range of 1.815V to 2.420V, yielding an LSB step size of 148 μ V. If a standard DAC were used with a 2.5V reference, then it would need 14 bits of resolution to get the same LSB step size.

The VH and VL pins can be used to monitor the selected reference voltage, or as inputs for external reference voltages. If an external voltage is to be applied to the VH or the VL pins, the Configuration Register must be set to value 000b for that reference to enable the external reference setting (see Table 1). An externally applied reference voltage can be time-varying, but the bandwidth of the device will limit its use as a multiplying DAC to less than 50kHz or so. The maximum voltage at the VH or VL pins is 3.1V. Note that although VH and VL can be used as inputs, the Reference pin (Vref) can only be used as an output.

The Configuration Register is a non-volatile register, so when a new VH or VL value is loaded it will be remembered each time the device is powered up after a power-down. This function is independent of the status of the NVDAC bit, which is used only for the DAC registers.

Output Buffer (X79000, X79001 only)

Note that although the voltage span as determined by V_H is limited to +3.1V max, the output buffer can drive voltages within 150mV of the positive rail. For a 5V \pm 5% V_{CC} supply, the DAC can have an output range up to $(4.75 - 0.150V) = 4.60V$. The buffer would need a gain >1 set by adding feedback resistors to the V_{buf} and V_{FB} pins, depending on the V_H voltage.

For applications requiring voltages greater than 5V, Intersil recommends the X79002 plus an external buffer.

UP/DOWN Operation

The UP/DOWN functionality of the chip uses the external pins UP, DOWN, \overline{CS} and CLR, and also the 2 LSB's of register 3Ch. The interface is designed to step up or down by the increments set in register 3Ch. When 12-bit operation is selected, then the LSB of the device (DAC0) will increment or decrement with the appropriate pin action. When 10-bit operation is selected, then third LSB of the device (DAC2) will change, while leaving the two LSB's unchanged. When 8-bit operation is selected, then the fifth LSB of the device (DAC4) will change, and the 4 LSB's are unchanged. These options allow the device to be used as either a 12-bit, 10-bit, or 8-bit DAC for UP/DOWN applications. The X79000 UP/DOWN interface allows stepping at up to 500kHz rates.

The CLR pin enables resetting the DAC output register to all zeroes and can be used to initialize the DAC before UP/DOWN operation.

FUNCTIONAL DESCRIPTION

DAC Register Clear Function

When the input pin CLR is set to logic high, the DAC volatile register and serial input registers are reset to 000 hex. CLR is an asynchronous input. CLR has an on-chip pulldown. CLR is ignored while $\overline{\text{RDY}}$ is high.

Buffer Output Enable Function

When the input pin OE is set to logic low, the DAC buffered output, Vbuf, is set to high impedance.

When the input pin OE is at a logic high, the DAC buffered output is enabled.

UP/DOWN Interface

The UP/DOWN Interface can be used to change the value of the DAC register without using the serial Interface.

The $\overline{\text{CS}}$ pin must be HIGH, when the UP/DOWN Interface is used, to set the serial interface in standby mode.

Control bits Count8 and Count10 determine the binary word that is incremented or decremented, according to the following table:

Count8	Count10	Part of DAC register incremented or decremented.
0	0	The complete 12 bit word is used
0	1	10 MSBs are used
1	0	8 MSBs are used
1	1	Reserved

These control bits are set by performing a Write Operation with the serial interface prior to operation of the UP/DOWN interface.





For example, when Count8 is one, the DAC register is affected by increment or decrement operations as follows:

8 MSBs	4 LSBs	
1000 1011	1110	Increment
1000 1010	1110	Increment
1000 1001	1110	Initial Value
1000 1000	1110	Decrement
1000 0111	1110	Decrement

A HIGH to LOW transition on the UP pin, while the DOWN pin is LOW, increments the selected binary word by one.

A HIGH to LOW transition on the DOWN pin, while the UP pin is LOW, decrements the selected binary word by one.

Other combinations are not valid. See the following table for a summary of these operations.

$\overline{\text{CS}}$	Up	Down	Mode
L	X	X	SPI Control
H		L	Increment
H	L		Decrement
H		H	Not Allowed
H	H		Not Allowed

X = Don't Care

$\overline{\text{RDY}}$ Pin

The $\overline{\text{RDY}}$ pin is an open drain output which will follow the V_{CC} voltage on power-up (due to the pullups) resistor and will transition to a low state at time t_{RDY} after V_{CC} reaches a minimum voltage ($V_{\overline{\text{RDY}}}$). As long as V_{CC} is higher the $V_{\overline{\text{RDY}}}$, the output will remain low. If V_{CC} falls below $V_{\overline{\text{RDY}}}$, the $\overline{\text{RDY}}$ output will return to a high state.

VOLTAGE REFERENCES

The device includes an on-chip bandgap reference circuit with 1.21 V nominal output voltage. This voltage is available at pin VRef as an output.

The voltages at pins VH and VL determine the DAC output voltage at full scale and zero scale respectively. Full scale is when the DAC input register is FFF hex (all ones), and zero scale is when the DAC input register is 000 hex (all zeros).

V(VH) and V(VL) can be generated on-chip and can be independently programmed to the values indicated in table 1. VH must always be at a higher voltage than VL. VH must not be higher than 3.1V. VL & VH can also be independently disabled, in which case they become inputs to the device.

SERIAL INTERFACE

Serial Interface Conventions

The device supports the SPI interface hardware protocol. The protocol defines any device that sends data onto the bus as a transmitter, and the receiving device as the receiver. The device controlling the transfer is called the master and the device being controlled is called the slave. The master always initiates data transfers, and provides the clock for both transmit and receive operations. The X79000 operates as a slave in all applications.

The device is accessed via the SI and SCK pins, while the output data is presented at the SO pin. Input data at pin SI is clocked-in on the rising edge of SCK, when \overline{CS} and \overline{RDY} are both LOW. Output data at pin SO is clocked-out on the falling edge of SCK.

All commands start with a falling edge at the input pin \overline{CS} . Write operations end with a rising edge at the input pin \overline{CS} after the last bit of the data bytes being written is clocked-in. Read operations end with a rising edge at the input pin \overline{CS} after the last bit of the data byte being read is clocked-out.

X79000 MEMORY MAP

The X79000 contains a 512-bit array of mixed volatile and nonvolatile memory. The array is organized as 64 bytes, and it's logically split up into two parts, namely:

- General Purpose Memory (GPM)
- Control and Status Registers

The GPM is all nonvolatile EEPROM, located at memory addresses 00h to 37h.

Figure 2. X79000 Memory Map

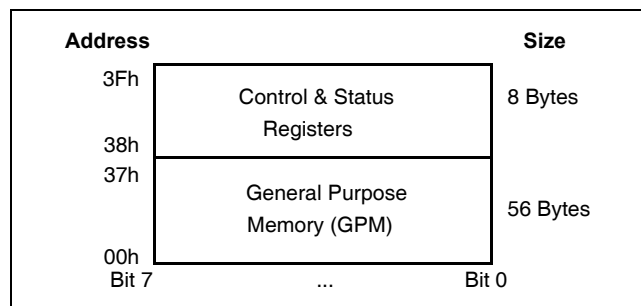

The Control and Status registers of the X79000 are used in the test and setup of the device in a system, and include the DAC volatile register and the DAC nonvolatile initial value register. These registers are realized as a combination of both volatile and nonvolatile memory. These registers reside in the memory locations 38h through 3Fh. The reserved bits within registers 38h through 3Dh must be written as "0" if writing to them, and should be ignored when reading. The reserved registers, 3Ah, 3Bh, 3Eh and 3Fh, must not be written, and their content should be ignored.

Factory control bit settings:

38h, 39h, 3Fh = All "0"s

3Ch = 1000 0100 (84 hex)

All communication to the X79000 over the SPI bus is conducted by sending the MSB of each byte of data first.

The memory is physically realized as one contiguous array, organized as 8 pages of 8 bytes each.

Table 1. Control Registers

Byte Address	MSB								LSB	Register Name	
	7	6	5	4	3	2	1	0			
38h Volatile or Non-volatile	DAC11	DAC10	DAC9	DAC8	DAC7	DAC6	DAC5	DAC4		MSBs of DAC Register	
39h Volatile or Non-volatile	DAC3	DAC2	DAC1	DAC0	Reserved	Reserved	Reserved	Reserved		LSBs of DAC Register	
3Ch Non-Volatile	VH2	VH1	VH0	VL2	VL1	VL0	Count8	Count10		Configuration Register	
	Full Scale Configuration 000: External VH reference 001: 605mV 010: 1.21V 011: 1.815V 100: 2.42V 101: 3.025V 110, 111: Reserved			Zero Level Configuration 000: External VL reference 001: 151mV 010: 605mV 011: 1.21V 100: 1.815V 101: 2.42V 110, 111: Reserved			Counter Configuration (for Up/Down Operation) 00: 12 bits 01: 10 bits 10: 8 bits 11: Reserved				
3Fh Volatile	NVDAC	Reserved	Reserved	Reserved	Reserved	Reserved	Reserved	Reserved		Non-Volatile Write Enable	

Bytes at addresses 3Ah, 3Bh, 3Dh, and 3Eh are reserved.

IDENTIFICATION AND MEMORY ADDRESS BYTES

The first byte sent to the X79000, following a falling edge at the \overline{CS} pin, is called the "Identification Byte". The most significant bit (ID7) is the function selector bit. The next six bits (ID6-ID1) are the Device Address bits (AS5-AS0). To communicate to the X79000, the value of bits AS[5:0] must correspond to the logic levels at pins A5, A4, A3, A2, A1, and A0 respectively. If one or more of the address pins doesn't exist in a particular device, then the corresponding device address bits must be set to "0". The LSB (ID0) is the R/\overline{W} bit. This bit defines the operation to be performed on the device being addressed. When the R/\overline{W} bit is "1", then a Read operation is selected. A "0" selects a write operation.

If the value of the Device Address bits doesn't match the logic levels at the Address pins, then the Read or Write operation is aborted.

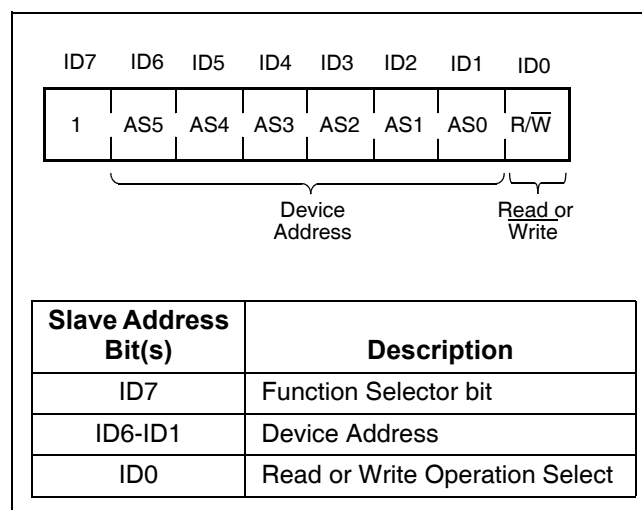

The byte sent to the X79000, immediately following the Identification byte, is called the Memory Address Byte. The value of this byte is the location of the first byte to be written to, or read from the X79000. Valid values for this byte are from 00h to 3Fh. If the value of the "Memory Address byte" is invalid, the Read or Write operation is aborted.

READ OPERATION

A Read Operation is selected when the R/\overline{W} bit in the Identification Byte is set to "1". During a Read Operation, the X79000 transmits Data Bytes at pin SO, starting at the first falling edge of SCK, following the rising edge of SCK that samples the LSB of the Memory Address Byte. The transmission continues until the \overline{CS} pin signal goes HIGH. The Data Bytes are from the memory location indicated by an internal pointer. This pointer initial value is the value of the Memory Address Byte, and increments by one during transmission of each Data Byte. After reaching memory location 3Fh, the pointer "rolls over" to 00h, and then it continues incremented by one during each following Data Byte transmission.

If bit "NVDAC" is "1" when reading from byte addresses 38h or 39h, the output is the content of the non-volatile DAC initial value register. If bit "NVDAC" is "0", the output is the current value in the volatile DAC register. See the next section for writing bit "NVDAC".

WRITE OPERATION

A "Write Operation" is selected when the R/\overline{W} bit in the Identification Byte is set to "0". The memory array of the X79000 is organized in 8 pages of 8 bytes each. A single write operation can be used to write between 1 to 8 bytes within the same page.

During a Write Operation, the Data Bytes are transmitted immediately following the Memory Address Byte.

The Data Bytes are written to the memory location indicated by an internal pointer. This pointer initial value is the value of the Memory Address Byte, and increments by one during reception of each Data Byte. After reaching the highest memory location within a page, the pointer "rolls over" to the lowest memory location of that page. The page address remains constant during a single write operation.

For example, if the Write operation includes 6 Data Bytes, and the Memory Address byte is 5 (decimal), the first 3 bytes are written to locations 5, 6, and 7, while the last 3 bytes are written to locations 0, 1, and 2. If the write operation includes more than 8 Data Bytes, the new data overwrites the previous data, one byte at a time.

Bytes at locations 38h through 3Fh are special cases. Bytes at locations 3Ah, 3Bh, 3Dh, and 3Eh, are reserved and must not be written. Reserved bits in other bytes must be set to "0" if writing to those bytes, and should be ignored when read. The DAC register Bytes at locations 38h & 39h must be written together in a single 2-Byte write operation.

Location 3Fh contains the "NVDAC" bit. If bit "NVDAC" is "1", the values of DAC[11:0] are written to non-volatile memory, otherwise they are written into volatile registers. Bit "NVDAC" is a volatile bit that has a "0" value at power-up. The "NVDAC" bit is set to "1" by writing 80h to byte location 3Fh. It is reset to "0" when the device is powered down or by writing 00h to byte location 3Fh.

The configuration byte at location 3Ch must be written as a single byte.

NON VOLATILE WRITE:

After a complete write command sequence is correctly received by the device, and if the write operation is to non volatile memory, then the X79000 enters an internal high voltage write cycle that last up to 10 ms.

The internal write cycle starts at the rising edge of \overline{CS} that completes the write instruction sequence. The progress of this internal operation can be monitored through the "Write In Progress", WIP, bit. The WIP bit is "1" during the internal write cycle and it's "0" otherwise. The WIP bit is read with a "Write Status Polling Command".

READ OPERATION

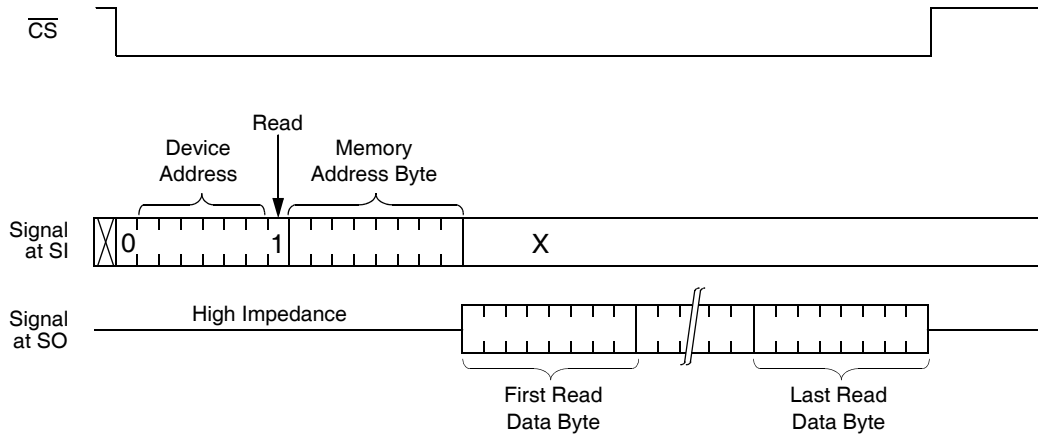

WRITE OPERATION

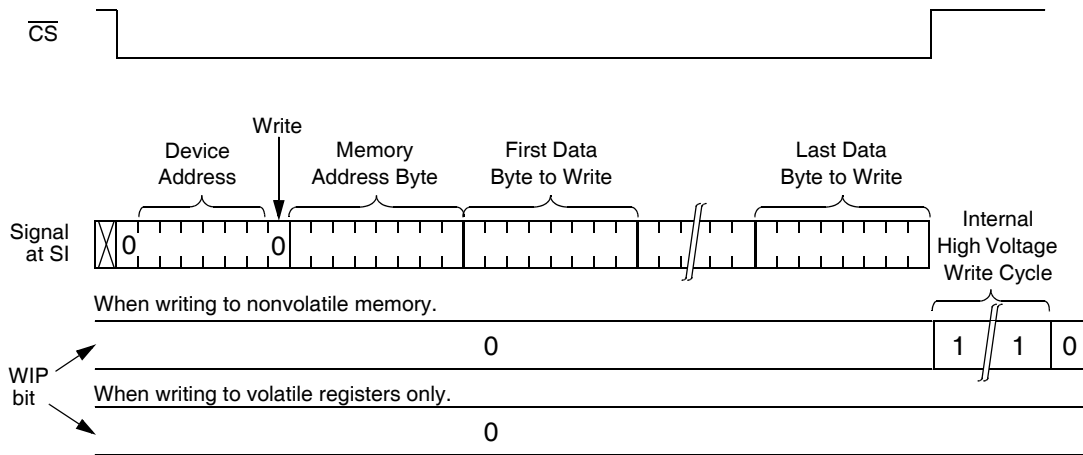

WRITE STATUS POLLING COMMAND

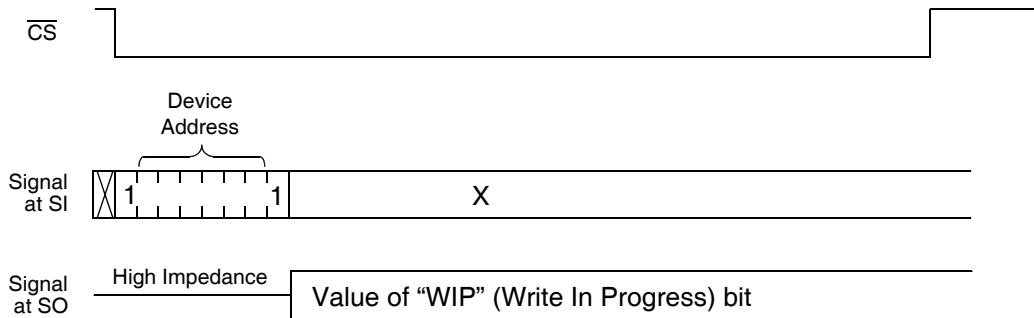

For every byte, the MSB is transmitted first and the LSB is sent last.

APPLICATIONS INFORMATION

Remote sensing

The output opamp included in the X79000 and X79001 is normally configured with a gain of +1, and since the inverting terminal is available externally, can be used for remote load sensing (see Figure 3). This configuration is useful for high accuracy applications which may draw significant current from the DAC output with a finite impedance from the DAC to the load. The inverting terminal must be brought as close as possible to the load, and there must be very low differential in the ground potentials of the two circuits.

Output Voltages Greater than 3.025V

The opamp output (V_{buf}) can drive up to $\pm 1\text{mA}$ and stay within 150mV of ground and the V_{CC} supply. Normally, if the opamp is configured with a gain of +1, V_{buf} is limited to 3.10V max, which is the limit of the DAC V_{out} . If gain is added to the opamp feedback loop, then V_{buf} can provide a higher output voltage, up to 4.85V with $V_{CC} = 5.00\text{V}$. Figure 4 shows a circuit with a gain of +2 that is configured for 4.84V max V_{buf} , with V_H internally set to 2.42V (V_{H2} , V_{H1} , V_{H0} set to 1,0,0). Care must be taken when increasing the maximum V_{buf} output, however, in this example V_{CC} may have a range of $\pm 5\%$, or 4.75V to 5.25V. The maximum V_{buf} can be expected to reach and stay within specifications is $4.75\text{V} - 150\text{mV} = 4.60\text{V}$. If the output offset of the DAC is included ($22\text{mV} \times 2$, worst case), then the max output will be $4.84\text{V} + 0.044\text{V} = 4.884\text{V}$. The designer has the option of either realizing that the DAC may miss the higher codes, or change the amplifier gain to a value less than 2 (or $4.60/2.42 = 1.90$, for this example) to keep all codes and reduce the maximum V_{buf} output.

Using the VH and VL pins for multiplying functions

When a time-varying waveform is applied at either reference input pin, the output reflects a scaled version of that waveform (see Figure 5). This waveform will follow the DAC output voltage equation when applied to V_H :

$$V_{buf} = [(V_H - V_L)(n/4095)] + V_L, n = 0 \text{ to } 4095$$

(excluding DAC, Reference scaling and opamp errors)

This shows that the input range for the waveform is limited to V_L on the low side, and by the V_{out} range (3.10V) on the high side. The output is scaled by the DAC setting to allow for gain control. The maximum output voltage can be increased as shown in Figure 4 using the opamp and V_{buf} output. It is advisable that the V_H pin be driven by a low impedance source for optimal AC performance. The minimum bandwidth of the circuit is 50kHz over all specified voltage range, temperature and output loading configurations.

Note that it is possible to use the V_L pin in the same fashion, with V_H fixed, but the resulting waveform will have a slightly different transfer function:

$$V_{buf} = V_H - (V_H - V_L)[(4095-n)/4095], n = 0 \text{ to } 4095$$

Alternatively, the V_L input could include a variable reference, such as a temperature sensor, or a shunt reference connected between V_H and V_L , which would fix their differential (the configuration register must be set for external V_H and V_L references). This provides a DAC output which varies proportional to temperature, yet can be set to an arbitrary voltage by the DAC for biasing applications.

FIGURE 3. REMOTE SENSING

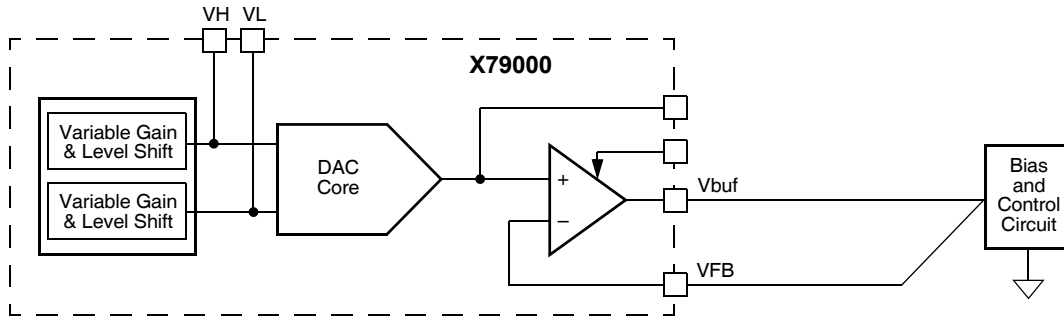

FIGURE 4. ACHIEVING HIGHER OUTPUT VOLTAGES

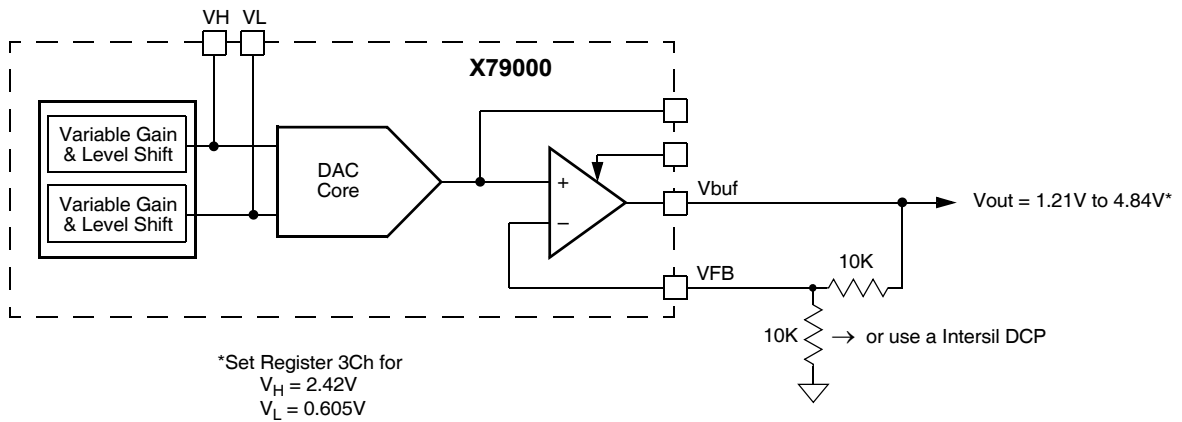
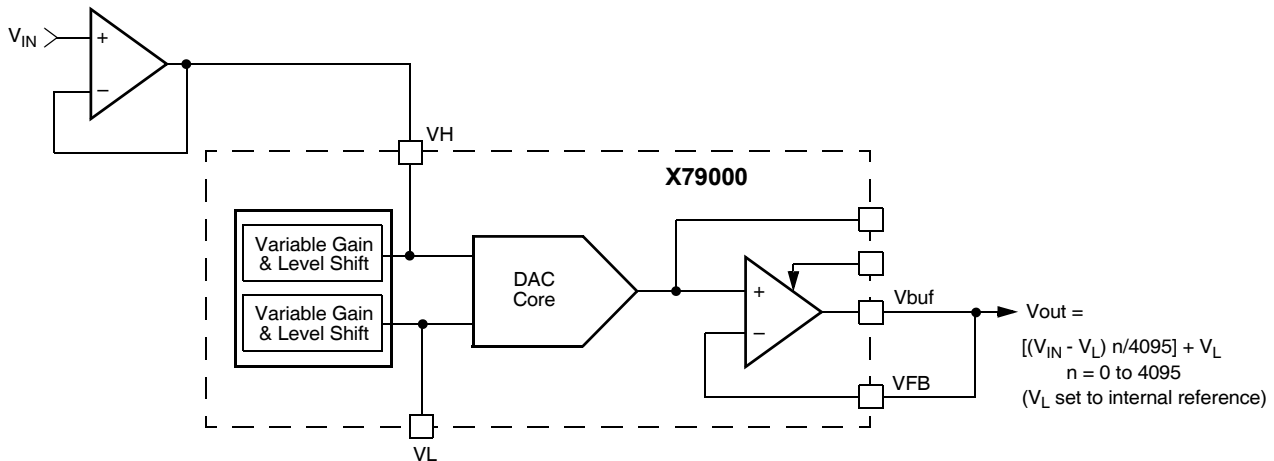
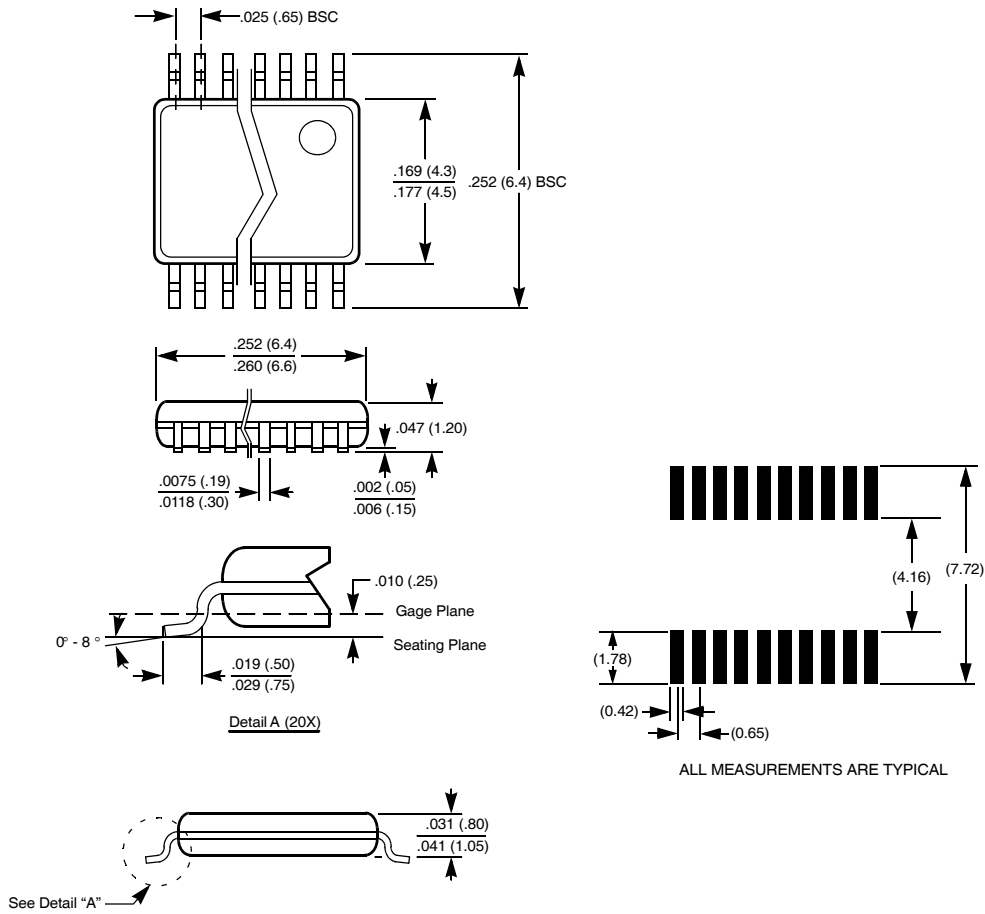

FIGURE 5. MULTIPLYING DAC CONFIGURATION



PACKAGING INFORMATION

20-LEAD PLASTIC, TSSOP PACKAGE TYPE V



NOTE: ALL DIMENSIONS IN INCHES (IN PARENTHESES IN MILLIMETERS)

© Copyright Intersil Americas LLC 2005. All Rights Reserved.

All trademarks and registered trademarks are the property of their respective owners.

For additional products, see www.intersil.com/en/products.html



Intersil products are manufactured, assembled and tested utilizing ISO9001 quality systems as noted in the quality certifications found at www.intersil.com/en/support/qualandreliability.html

Intersil products are sold by description only. Intersil may modify the circuit design and/or specifications of products at any time without notice, provided that such modification does not, in Intersil's sole judgment, affect the form, fit or function of the product. Accordingly, the reader is cautioned to verify that datasheets are current before placing orders. Information furnished by Intersil is believed to be accurate and reliable. However, no responsibility is assumed by Intersil or its subsidiaries for its use; nor for any infringements of patents or other rights of third parties which may result from its use. No license is granted by implication or otherwise under any patent or patent rights of Intersil or its subsidiaries.

For information regarding Intersil Corporation and its products, see www.intersil.com

Looking for pricing, stock, or lifecycle information?

Click below to explore more details on WIN SOURCE:

-  [View X79000V20I on WIN SOURCE](#)
-  [Renesas Electronics America](#) Information

Optimize Your Supply Chain with WIN SOURCE Solutions

-  Global Sourcing Solution
-  Obsolete Management
-  Cost Control Management
-  Shortage Management
-  Alternative Solution
-  Excess Inventory Management