



**THE DATASHEET OF
MAX6947ATE+**



10-Port, Constant-Current LED Driver and I/O Expander with PWM Intensity Control

General Description

The MAX6946/MAX6947 I²C-/SMBusTM-compatible, serial-interfaced peripherals provide microprocessors with 10 I/O ports rated to 7V.

Each port can be configured as a 2.5mA to 20mA constant-current LED driver (static or PWM), a 1.25mA to 10mA constant-current LED driver (static or PWM), an open-drain logic output, or an overvoltage-protected Schmitt logic input.

Analog and switching LED intensity control includes individual 8-bit PWM control per output, individual 1-bit analog current control (half/full scale) per output, and a global 3-bit DAC current control that applies to all LED outputs.

The MAX6946/MAX6947 can stagger the PWM timing of the 10-port outputs in consecutively phased 45° increments. Staggering the outputs spreads the PWM load currents over time in eight steps, helping to even out the power-supply current and reduce the RMS current.

For a similar part with an SPITM/QSPITM/ or MICROWIRETM-compatible interface, refer to the MAX6966/MAX6967 data sheet.

Applications

Cellular Phones	LCD Backlights
Portable Equipment	Keypad Backlights
RGB LED Drivers	LED Status Indicators

Typical Operating Circuit

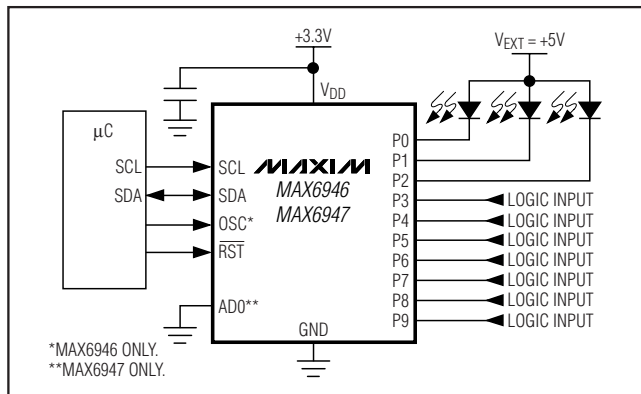

SMBus is a trademark of Intel Corp.

SPI and QSPI are trademarks of Motorola, Inc.

MICROWIRE is a trademark of National Semiconductor Corp.

Features

- ◆ 2.25V to 3.6V Operation
- ◆ I/O Ports Default to High Impedance (LEDs Off) on Power-Up
- ◆ I/O Port Inputs Are Overvoltage Protected to 7V
- ◆ I/O Port Outputs Are 7V-Rated Open-Drain, 10mA or 20mA Constant-Current Static/PWM LED Drivers, or Open-Drain Logic Outputs
- ◆ I/O Ports Support Hot Insertion
- ◆ Individual 8-Bit PWM Intensity Control for Each LED
- ◆ RST Input Clears Serial Interface and Can Exit Shutdown (Warm Start)
- ◆ MAX6946 OSC Input Allows for External PWM Clock Input
- ◆ MAX6947 ADO Input Selects from Two Slave Addresses
- ◆ Auto Ramp-Up Out of Shutdown, and Up to 4s Hold-Off Before Ramp-Down into Shutdown
- ◆ 0.8µA (typ) Shutdown Current
- ◆ -40°C to +125°C Temperature Range
- ◆ Tiny WLP Package (4 x 4 Grid)

Ordering Information

PART	PIN-PACKAGE	PKG CODE
MAX6946ATE+	16 TQFN-EP*	T1633-4
MAX6946CAWE+	16 WLP	W162B2-1
MAX6947ATE+	16 TQFN-EP*	T1633-4

+Denotes a lead-free package.

*EP = Exposed pad.

Note: All devices are specified over the -40°C to +125°C operating temperature range..

Pin Configurations

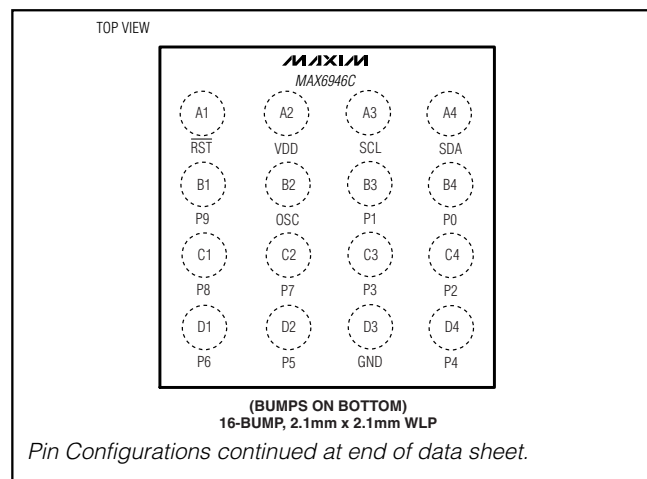

10-Port, Constant-Current LED Driver and I/O Expander with PWM Intensity Control

ABSOLUTE MAXIMUM RATINGS

VDD to GND	-0.3V to +4V
SCL, SDA, ADO, RST, OSC to GND	-0.3V to +6V
P0 to P9 to GND	-0.3V to +8V
DC Current into P0 to P9	24mA
DC Current into SDA	10mA
RST Sink Current	10mA
Total GND Current	280mA

Continuous Power Dissipation (TA = +70°C)	
16-Pin TQFN (derate 14.7mW/°C over +70°C)	1176mW
16-Bump WLP (derate 13.3mW/°C over +70°C)	1066mW
Operating Temperature Range (TMIN, TMAX)	-40°C to +125°C
Junction Temperature	+150°C
Storage Temperature Range	-65°C to +150°C
Lead Temperature (soldering, 10s)	+300°C

Stresses beyond those listed under "Absolute Maximum Ratings" may cause permanent damage to the device. These are stress ratings only, and functional operation of the device at these or any other conditions beyond those indicated in the operational sections of the specifications is not implied. Exposure to absolute maximum rating conditions for extended periods may affect device reliability.

ELECTRICAL CHARACTERISTICS

(VDD = 2.25V to 3.6V, TA = TMIN to TMAX, unless otherwise noted. Typical values are at VDD = 3.3V, TA = +25°C.) (Note 1)

PARAMETER	SYMBOL	CONDITIONS		MIN	TYP	MAX	UNITS
Operating Supply Voltage	VDD			2.25		3.60	V
Output Load External Supply Voltage P0–P9	VEXT					7	V
Power-On-Reset Voltage	VPOR	VDD rising				1.91	V
Power-On-Reset Voltage Hysteresis	PORHYS	16-pin TQFN				128	mV
		16-bump WLP				33	
Standby Current Interface Idle (PWM Disabled, All Ports High Impedance)	ISTBY	RST at VDD; fSCL = 0Hz; other digital inputs at VDD or GND	TA = +25°C		1.0	1.3	µA
			TA = TMIN to +85°C			1.3	
			TA = TMIN to TMAX			1.5	
Standby Current in Reset (PWM Disabled, All Ports High Impedance)	IRST	RST at GND; fSCL = 400kHz; other digital inputs at VDD or GND	TA = +25°C		17	23	µA
			TA = TMIN to +85°C			24	
			TA = TMIN to TMAX			25	
Supply Current Interface Active (Reset Run Enabled, PWM Disabled, All Ports High Impedance)	IDD	fSCL = 400kHz; other digital inputs at VDD or GND	TA = +25°C		50	60	µA
			TA = TMIN to +85°C			62	
			TA = TMIN to TMAX			65	
Delta Supply Current Interface Idle	ΔIDD10	One port set to 10mA constant current; all other ports' output registers set to 0x00, 0x01, or 0xFF; digital inputs at VDD or GND	TA = +25°C		1.58	1.8	mA
			TA = TMIN to +85°C			1.9	
			TA = TMIN to TMAX			2.0	
	ΔIDD20	One port set to 20mA constant current; all other ports' output registers set to 0x00, 0x01, or 0xFF; digital inputs at VDD or GND	TA = +25°C		3.2	3.6	
			TA = TMIN to +85°C			3.8	
			TA = TMIN to TMAX			4.0	

10-Port, Constant-Current LED Driver and I/O Expander with PWM Intensity Control

MAX6946/MAX6947

ELECTRICAL CHARACTERISTICS (continued)

(V_{DD} = 2.25V to 3.6V, T_A = T_{MIN} to T_{MAX}, unless otherwise noted. Typical values are at V_{DD} = 3.3V, T_A = +25°C.) (Note 1)

PARAMETER	SYMBOL	CONDITIONS	MIN	TYP	MAX	UNITS	
Input High Voltage (P0–P9, SDA, SCL, $\overline{\text{RST}}$, AD0, OSC)	V _{IH}	P0–P9: output register set to 0x01	0.7 x V _{DD}			V	
Input Low Voltage (P0–P9, SDA, SCL, $\overline{\text{RST}}$, AD0, OSC)	V _{IL}	P0–P9: output register set to 0x01			0.3 x V _{DD}	V	
Input Leakage Current (P0–P9, SDA, SCL, $\overline{\text{RST}}$, AD0, OSC)	I _{IH} , I _{IL}		-0.2		+0.2	μA	
Input Capacitance (P0–P9, SDA, SCL, $\overline{\text{RST}}$, AD0, OSC)				10		pF	
10mA Port Nominal Sink Constant Current (P0–P9)	I _{OUT}	Output register set to 0x02, V _{DD} = 3.3V, V _{EXT} - V _{LED} = 1V (Note 3)	T _A = +25°C	9.3	10	10.5	mA
			T _A = T _{MIN} to +85°C 16-pin TQFN	9.1		11.0	
			T _A = T _{MIN} to +85°C 16-bump WLP	9.0		11.0	
20mA Port Nominal Sink Constant Current (P0–P9)	I _{OUT}	Output register set to 0x02, V _{DD} = 3.3V, V _{EXT} - V _{LED} = 1V (Note 3)	T _A = +25°C	19.00	20	21.12	mA
			T _A = T _{MIN} to +85°C 16-pin TQFN	18.6		21.8	
			T _A = T _{MIN} to +85°C 16-bump WLP	18.4		22.0	
Port Sink Constant-Current Matching	ΔI _{OUT}	T _A = +25°C, V _{DD} = 3.3V, V _{P0} to V _{P9} = 1.4V, I _{OUT} = 20mA		±2.0	±4.0	%	
		T _A = +25°C, V _{DD} = 3.3V, V _{P0} to V _{P9} = 1.4V, I _{OUT} = 10mA		±2.0	±5.0		
Port Logic Output Low Voltage (P0–P9)	V _{OLP_}	Output register set to 0x00, I _{SINK} = 0.5mA			0.5	V	
Port Logic Output Low Short-Circuit Current (P0–P9)		Output register set to 0x00, V _{OLP_} = 5V		10		mA	
Port Slew Time		From 20% current to 80% current		2		μs	
Output Low Voltage (SDA)	V _{OLSDA}	I _{SINK} = 6mA			300	mV	

10-Port, Constant-Current LED Driver and I/O Expander with PWM Intensity Control

TIMING CHARACTERISTICS (Figure 8)

($V_{DD} = 2.25V$ to $3.6V$, $T_A = T_{MIN}$ to T_{MAX} , unless otherwise noted. Typical values are at $V_{DD} = 3.3V$, $T_A = +25^{\circ}C$.) (Note 1)

PARAMETER	SYMBOL	CONDITIONS		MIN	TYP	MAX	UNITS
Internal PWM Clock Frequency	f_{INT}	16-pin TQFN		23	32	42	kHz
		16-bump WLP		20	32	45	
External PWM Clock Frequency	f_{OSC}					100	kHz
Serial-Clock Frequency	f_{SCL}					400	kHz
Bus Free Time Between a STOP and a START Condition	t_{BUF}			1.3			μs
Hold Time, (Repeated) START Condition	$t_{HD, STA}$			0.6			μs
Repeated START Condition Setup Time	$t_{SU, STA}$			0.6			μs
STOP Condition Setup Time	$t_{SU, STO}$			0.6			μs
Data Hold Time	$t_{HD, DAT}$	(Note 3)				0.9	μs
Data Setup Time	$t_{SU, DAT}$			180			ns
SCL Clock Low Period	t_{LOW}			1.3			μs
SCL Clock High Period	t_{HIGH}			0.7			μs
Rise Time of Both SDA and SCL Signals, Receiving	t_R	(Notes 4, 5)			20 + 0.1 C_b	300	ns
Fall Time of Both SDA and SCL Signals, Receiving	t_F	(Notes 4, 5)			20 + 0.1 C_b	300	ns
Fall Time of SDA Transmitting	$t_{F, TX}$	(Notes 4, 6)			20 + 0.1 C_b	250	ns
Pulse Width of Spike Suppressed	t_{SP}	(Note 7)			50		ns
Capacitive Load for Each Bus Line	C_b	(Note 4)				400	pF
\overline{RST} Pulse Width	t_W			0.1			μs
\overline{RST} Rising Edge to MAX6946/MAX6947 ACK to Cancel Reset Run	t_{RSTRUN}	Reset Run enabled, internal oscillator enabled	16-pin TQFN			3.0	ms
			16-bump WLP			2.5	
\overline{RST} Rising Edge to MAX6946/MAX6947 ACK to Ensure Reset Run	t_{RSTRUN}	Reset Run enabled, internal oscillator enabled		5.6			ms

Note 1: All parameters are tested at $T_A = +25^{\circ}C$. Specifications over temperature are guaranteed by design.

Note 2: Port current is factory trimmed to meet a median sink current of 20mA and 10mA over all ports. The ΔI_{OUT} specification guarantees current matching between parts.

Note 3: A master device must provide a hold time of at least 300ns for the SDA signal (referred to V_{IL} of the SCL signal) in order to bridge the undefined region of SCL's falling edge.

Note 4: Not production tested. Guaranteed by design.

Note 5: C_b = total capacitance of one bus line in picoFarads; t_R and t_F are measured between $0.3 \times V_{DD}$ and $0.7 \times V_{DD}$.

Note 6: $I_{SINK} \leq 6mA$.

Note 7: Guaranteed by design. Input filters on the SDA and SCL inputs suppress noise spikes of less than 50ns.

10-Port, Constant-Current LED Driver and I/O Expander with PWM Intensity Control

Typical Operating Characteristics

($T_A = +25^\circ\text{C}$, unless otherwise noted.)

MAX6946/MAX6947

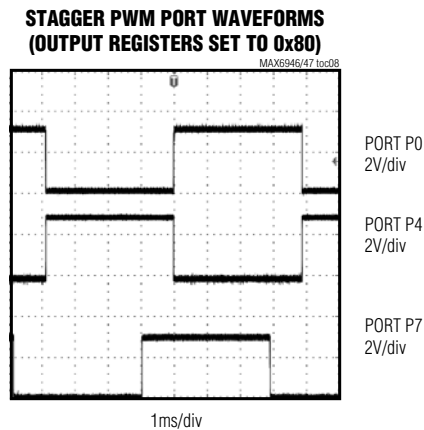
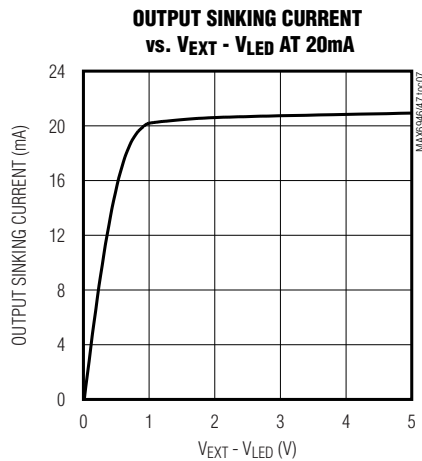
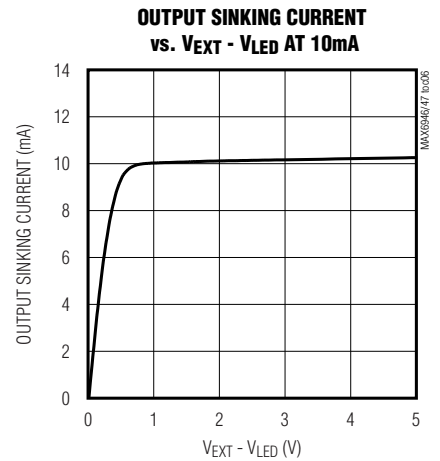
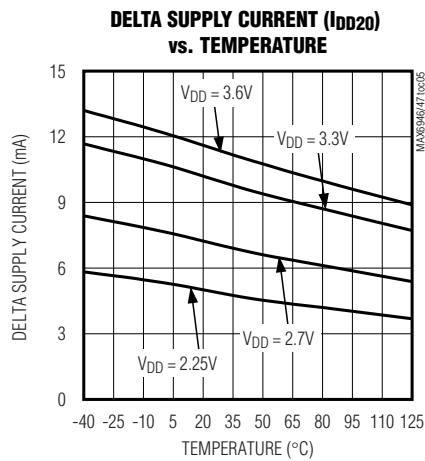
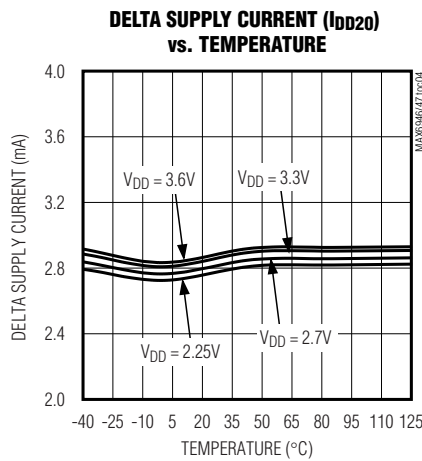
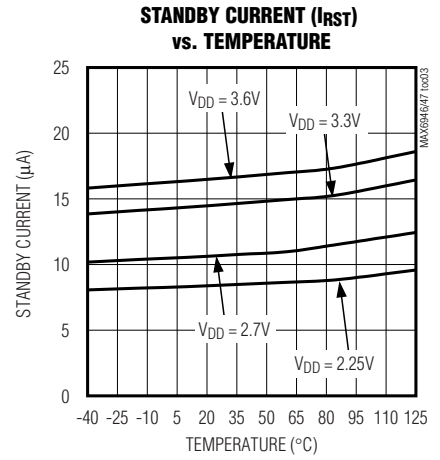
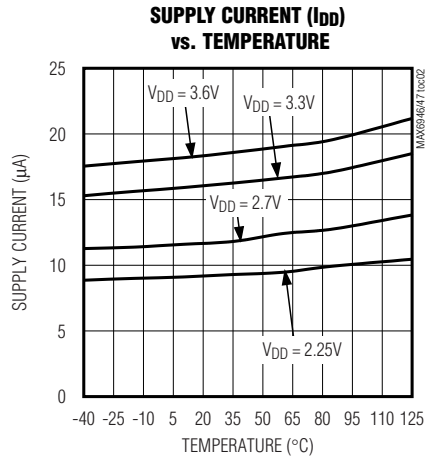
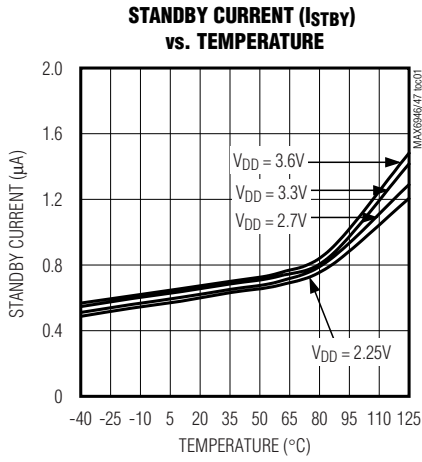

10-Port, Constant-Current LED Driver and I/O Expander with PWM Intensity Control

Pin Description

PIN		NAME	FUNCTION
MAX6946/ MAX6947	MAX6946C		
1	B4	P0	I/O Ports. Configure P0–P4 as open-drain current sink outputs rated at 20mA (max), as CMOS-logic inputs, or as open-drain logic outputs. Connect loads to a supply voltage no higher than 7V.
2	B3	P1	
3	C4	P2	
4	C3	P3	
5	D4	P4	
6	D3	GND	Ground
7	D2	P5	I/O Ports. Configure P5–P9 as open-drain current sink outputs rated at 20mA (max), as CMOS-logic inputs, or as open-drain logic outputs. Connect loads to a supply voltage no higher than 7V.
8	D1	P6	
9	C2	P7	
10	C1	P8	
11	B1	P9	
12	B2	OSC (MAX6946)	External Oscillator Input
		AD0 (MAX6947)	Address Input. Sets the device slave address (see Table 10).
13	A1	$\overline{\text{RST}}$	Active-Low Reset Input
14	A2	VDD	Positive Supply Voltage. Bypass VDD to GND with a 0.1µF ceramic capacitor.
15	A3	SCL	I ² C-Compatible, Serial-Clock Input
16	A4	SDA	I ² C-Compatible, Serial-Data I/O
—	—	EP	Exposed Pad on Package Underside. Connect to GND. Do not use as the main ground connection.

Block Diagram

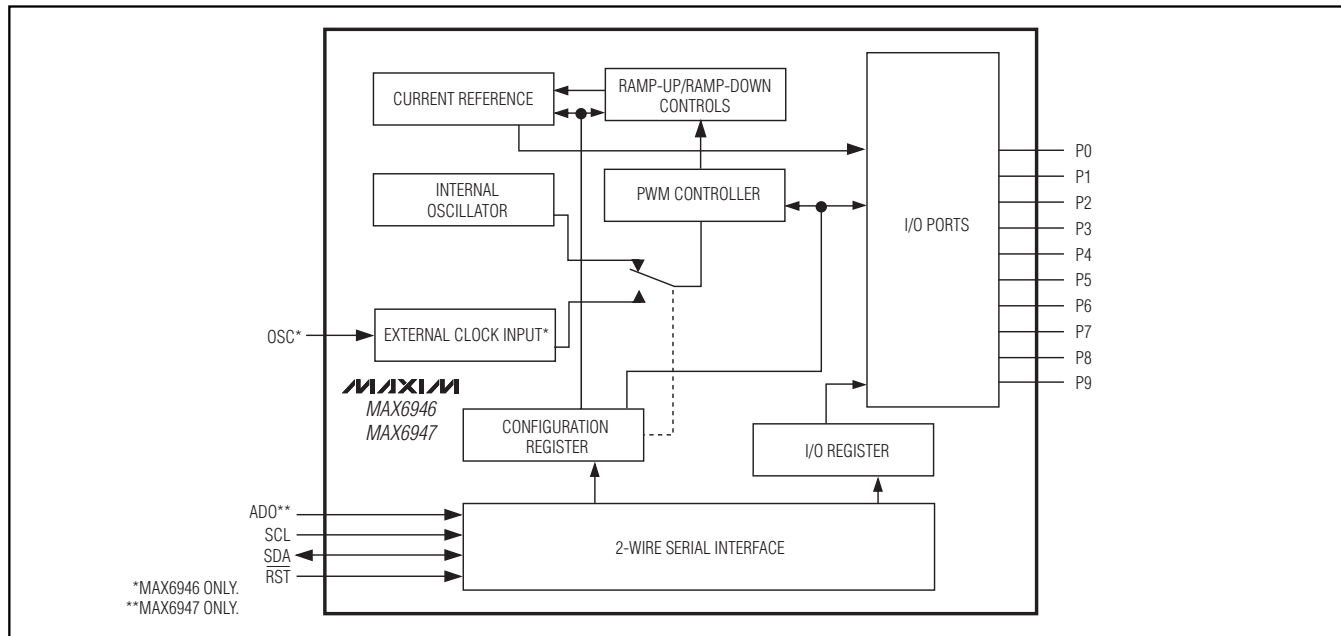

10-Port, Constant-Current LED Driver and I/O Expander with PWM Intensity Control

Detailed Description

The MAX6946/MAX6947 general-purpose input/output (GPIO) peripherals provide 10 I/O ports, P0 to P9, controlled through an I²C-compatible serial interface. Use the 10 I/O ports as logic inputs, open-drain logic outputs, or constant-current sinks in any combination. Ports withstand 7V independent of the MAX6946/MAX6947s' supply voltage whether used as logic inputs, logic outputs, or constant-current sinks.

The MAX6946/MAX6947 feature shutdown and standby modes for low-power dissipation. The I/O ports feature pulse-width modulation (PWM) of the outputs and can stagger the PWM timing of the 10 port outputs in consecutively phased 45° increments. The I/O ports also feature ramp-up and ramp-down controls.

The MAX6946/MAX6947 feature a $\overline{\text{RST}}$ input to halt any serial-interface transmission and bring the device out of shutdown.

Open-drain logic outputs require external pullup resistors to provide the logic-high reference. Ports configured as open-drain logic outputs have a relatively weak sink capability, but are still adequate for normal logic-level outputs. The weak drive means that the short-circuit current is low enough that inadvertently driving an LED from a port configured as a logic output is unlikely to damage the LED.

The MAX6946 features a fixed I²C slave address of 010 0000 and provides an OSC input to accept an external PWM clock input as an alternative to the internal PWM clock.

The MAX6947 features an AD0 input that uses two-level logic to select from two I²C slave addresses. The MAX6947 always uses the internal PWM clock.

Register Structure

The MAX6946/MAX6947 contain 22 internal registers (see Table 1). Use registers 0x00 to 0x09 to individually control ports P0 to P9. Registers 0x0A to 0x0D allow more than one port control register to be written with the same data to simplify software. Registers 0x0E and 0x0F do not store data, but return the port input status when read. Registers 0x10 to 0x15 configure and control the device operation.

Table 1. Register Address Map

DESCRIPTION	ADDRESS CODE (HEX)	AUTO-INCREMENT ADDRESS
Port P0 output level or PWM	0x00	0x01
Port P1 output level or PWM	0x01	0x02
Port P2 output level or PWM	0x02	0x03
Port P3 output level or PWM	0x03	0x04
Port P4 output level or PWM	0x04	0x05
Port P5 output level or PWM	0x05	0x06
Port P6 output level or PWM	0x06	0x07
Port P7 output level or PWM	0x07	0x08
Port P8 output level or PWM	0x08	0x09
Port P9 output level or PWM	0x09	0x10
Write ports P0–P9 with same output level or PWM	0x0A	0x10
Read port P0 output level or PWM		
Write ports P0–P3 with same output level or PWM	0x0B	0x10
Read port P0 output level or PWM		
Write ports P4–P7 with same output level or PWM	0x0C	0x10
Read port P4 output level or PWM		
Write ports P8 or P9 with same output level or PWM	0x0D	0x10
Read port P8 output level or PWM		
Read ports P7–P0 inputs	0x0E	0x0F
Read ports P9 and P8 inputs	0x0F	0x0E
Configuration	0x10	0x11
Ramp-down	0x11	0x12
Ramp-up	0x12	0x13
Output current ISET70	0x13	0x14
Output current ISET98	0x14	0x15
Global current	0x15	0x10
Factory reserved; do not write to this register	0x7D	—

MAX6946/MAX6947

10-Port, Constant-Current LED Driver and I/O Expander with PWM Intensity Control

Configuration Register (0x10)

Use the configuration register to select PWM phasing between outputs, test fade status, enable hardware startup from shutdown, and select shutdown or run mode (Table 2).

Initial Power-Up

All control registers reset upon power-up (Table 3). Power-up status sets I/O ports P0 to P9 to high impedance, and puts the device into shutdown. The MAX6946/MAX6947 powers up in shutdown.

Table 2. Configuration Register (0x10)

REGISTER BIT	DESCRIPTION	VALUE	FUNCTION
D7	OSC enable*	0	Internal oscillator enabled as PWM clock source
		1	External oscillator input enabled as PWM clock source
D6	RSTPOR options	0	$\overline{\text{RST}}$ does not change register data
		1	$\overline{\text{RST}}$ resets registers to POR (power-on reset) state
D5	PWM stagger	0	PWM outputs are in phase
		1	PWM outputs stagger phase
D4	Hold-off status**	0	Device not in hold-off
		1	Device in hold-off
D3	Fade-off status**	0	Device not in fade-off
		1	Device in fade-off
D2	Ramp-up status**	0	Device not in ramp-up
		1	Device in ramp-up
D1	$\overline{\text{RST}}$ RUN enable	0	Reset Run disabled
		1	Reset Run enabled
D0	RUN enable	0	Shutdown mode
		1	Run mode

*The OSCEN bit applies only to the MAX6946. OSCEN is always 0 for the MAX6947, and the MAX6947 ignores writes to the OSCEN bit.

**Read-only bits.

Table 3. Initial Power-Up Register Status

DESCRIPTION	POWER-UP CONDITION	ADDRESS CODE (HEX)	REGISTER BIT							
			D7	D6	D5	D4	D3	D2	D1	D0
Port P0–P9 output level or PWM	Port 0–9 high impedance	0x00–0x09	1	1	1	1	1	1	1	1
Configuration	Shutdown mode, Reset Run disabled	0x10	0/1*	0	0	0	0	0	0	0
Ramp-down/hold-off	Fade/hold-off disabled	0x11	0	0	0	0	0	0	0	0
Ramp-up	Disabled	0x12	0	0	0	0	0	0	0	0
Output current ISET70	$I_{\text{PEAK}} = 10\text{mA}$ for ports P7–P0	0x13	0	0	0	0	0	0	0	0
Output current ISET98	$I_{\text{PEAK}} = 10\text{mA}$ for ports P9, P8	0x14	0	0	0	0	0	0	0	0
Global current	Full current	0x15	0	0	0	0	0	1	1	1

*Value is 0 for MAX6947 and 1 for MAX6946 bit.

10-Port, Constant-Current LED Driver and I/O Expander with PWM Intensity Control

I/O Ports

The MAX6946/MAX6947 contain 10 I/O ports. Configure the 10 I/O ports as logic inputs, open-drain logic outputs, or constant-current sinks in any combination. Table 4 shows a detailed description of the individual port configuration registers 0x00 through 0x09. Use registers 0x00–0x09 to individually assign each port as a logic input, open-drain logic output or constant-current sink (see the *PWM Intensity Control and*

Phasing section). The I/O ports are high impedance without V_{DD} applied and remain high impedance upon power-up.

Figure 1 shows the I/O port structure of the MAX6946/MAX6947. I/O ports P0 to P9 default to high impedance on power-up, so LEDs or other port loads connected draw no current. Ports used as inputs do not load their source signals.

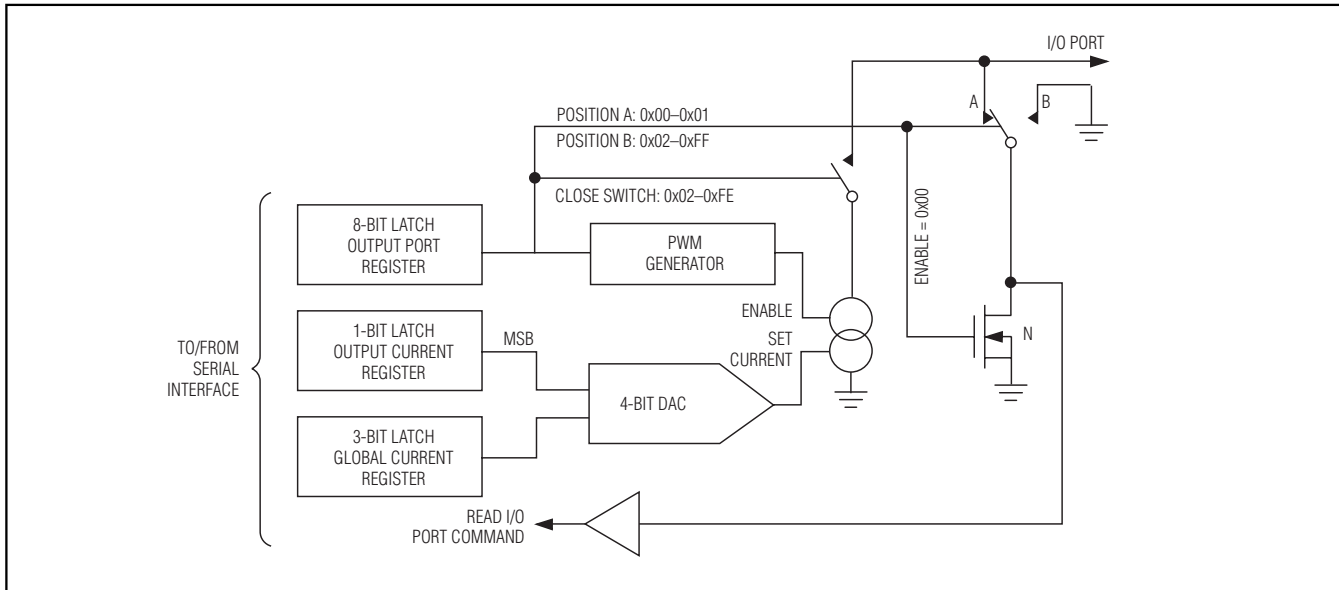

Figure 1. Simplified Schematic of I/O Ports

Table 4. Individual Port Configuration Options (Port Output Registers 0x00–0x09)

PORT TYPE	OUTPUT REGISTER CODE	RUN MODE (CONFIGURATION REGISTER BIT D0 = 1)	SHUTDOWN (CONFIGURATION REGISTER BIT D0 = 0)	APPLICATION NOTES
Low-logic output	0x00	Logic-low output, not constant current		Lowest supply current, unaffected by shutdown
High-logic output	0x01	Logic-high output with external pullup resistor; otherwise, high impedance		
Logic input		CMOS logic input		
Constant-current static sink output	0x02	Static constant-current sink output	High impedance	Full constant-current drive with no PWM
Constant-current PWM output	0x03–0xFE	0x03 = 3/256 PWM duty cycle 0xFE = 254/256 PWM duty cycle		Adjustable constant current
LED off	0xFF	Logic-high output with external pullup resistor; otherwise, high impedance		LED off

10-Port, Constant-Current LED Driver and I/O Expander with PWM Intensity Control

Ports Configured as Outputs

The global-current register sets the full (maximum) constant-current sink into an I/O port configured as an output (Table 5). Each output port's individual constant-current sink can set to either half or full scale of the global current by the output-current registers (Table 6). By default, maximum current is 20mA, hence the default maximum half current is 10mA.

Set each output port's individual constant-current sink to either half scale or full scale of the global current.

Use the output-current registers to set the individual currents (Table 6). Set the global current by the global-current register (Table 5).

Set each output current individually to best suit the maximum operating current of an LED load, or even adjust on the fly to double the effective intensity control range of each output. The individual current selection is 10mA (half) or 20mA (full) when setting the global-current register to its maximum value.

Table 5. Global-Current Register Format (0x15)

DESCRIPTION	REGISTER BIT							
	D7	D6	D5	D4	D3	D2	D1	D0
Full current is 2.5mA; half current is 1.25mA	X	X	X	X	X	0	0	0
Full current is 5mA; half current is 2.5mA	X	X	X	X	X	0	0	1
Full current is 7.5mA; half current is 3.75mA	X	X	X	X	X	0	1	0
Full current is 10mA; half current is 5mA	X	X	X	X	X	0	1	1
Full current is 12.5mA; half current is 6.25mA	X	X	X	X	X	1	0	0
Full current is 15mA; half current is 7.5mA	X	X	X	X	X	1	0	1
Full current is 17.5mA; half current is 8.75mA	X	X	X	X	X	1	1	0
Full current is 20mA; half current is 10mA	X	X	X	X	X	1	1	1

Table 6. Output-Current Register Format

DESCRIPTION	ADDRESS CODE (HEX)	REGISTER BIT							
		D7	D6	D5	D4	D3	D2	D1	D0
Output P0 is set to half constant current	0x13	X	X	X	X	X	X	X	0
Output P0 is set to full constant current		X	X	X	X	X	X	X	1
Output P1 is set to half constant current		X	X	X	X	X	X	0	X
Output P1 is set to full constant current		X	X	X	X	X	X	1	X
Output P2 is set to half constant current		X	X	X	X	X	0	X	X
Output P2 is set to full constant current		X	X	X	X	X	1	X	X
Output P3 is set to half constant current		X	X	X	X	0	X	X	X
Output P3 is set to full constant current		X	X	X	X	1	X	X	X
Output P4 is set to half constant current		X	X	X	0	X	X	X	X
Output P4 is set to full constant current		X	X	X	1	X	X	X	X
Output P5 is set to half constant current		X	X	0	X	X	X	X	X
Output P5 is set to full constant current		X	X	1	X	X	X	X	X
Output P6 is set to half constant current		X	0	X	X	X	X	X	X
Output P6 is set to full constant current		X	1	X	X	X	X	X	X
Output P7 is set to half constant current		0	X	X	X	X	X	X	X
Output P7 is set to full constant current		1	X	X	X	X	X	X	X
Output P8 is set to half constant current	0x14	X	X	X	X	X	X	X	0
Output P8 is set to full constant current		X	X	X	X	X	X	X	1
Output P9 is set to half constant current		X	X	X	X	X	X	0	X
Output P9 is set to full constant current		X	X	X	X	X	X	1	X

10-Port, Constant-Current LED Driver and I/O Expander with PWM Intensity Control

PWM Intensity Control and Phasing

The MAX6946/MAX6947 use an internal 32kHz oscillator to generate PWM timing for LED intensity control. The MAX6946 also features an OSC input to allow for an external clock for generating PWM timing for LED intensity control. Select the PWM clock source for the MAX6946 with configuration register bit D7 (Table 2). The MAX6947 powers up configured to use the internal 32kHz oscillator by default. The MAX6946 powers up configured to use the external clock source by default.

A PWM period comprises 256 cycles of the nominal 32kHz PWM clock (Figure 2). Individually set the ports' PWM duty cycle between 3/256 and 254/256. See Table 4 for port register settings.

Configure PWM timing by setting the stagger bit in the configuration register (Table 2), either with output staggering or without. Clearing the stagger bit causes all outputs using PWM to switch at the same time using

the timing shown in Figure 2. All outputs, therefore, draw load current at the exactly same time for the same PWM setting. This means that if, for example, all outputs are set to 0x80 (128/256 duty cycle), the current draw would be zero (all loads off) for half the time, and full (all loads on) for the other half.

Setting the stagger bit causes the PWM timing of the 10 port outputs to stagger by 32 counts of the 256-count PWM period (i.e., 1/8th), distributing the port output switching points across the PWM period (Figure 3). Staggering reduces the di/dt output-switching transient on the supply and also reduces the peak/mean current requirement.

Set or clear the stagger bit during shutdown. Changing the stagger bit during normal operation can cause a transient flicker in any PWM-controlled LEDs because of the fundamental PWM timing changes.

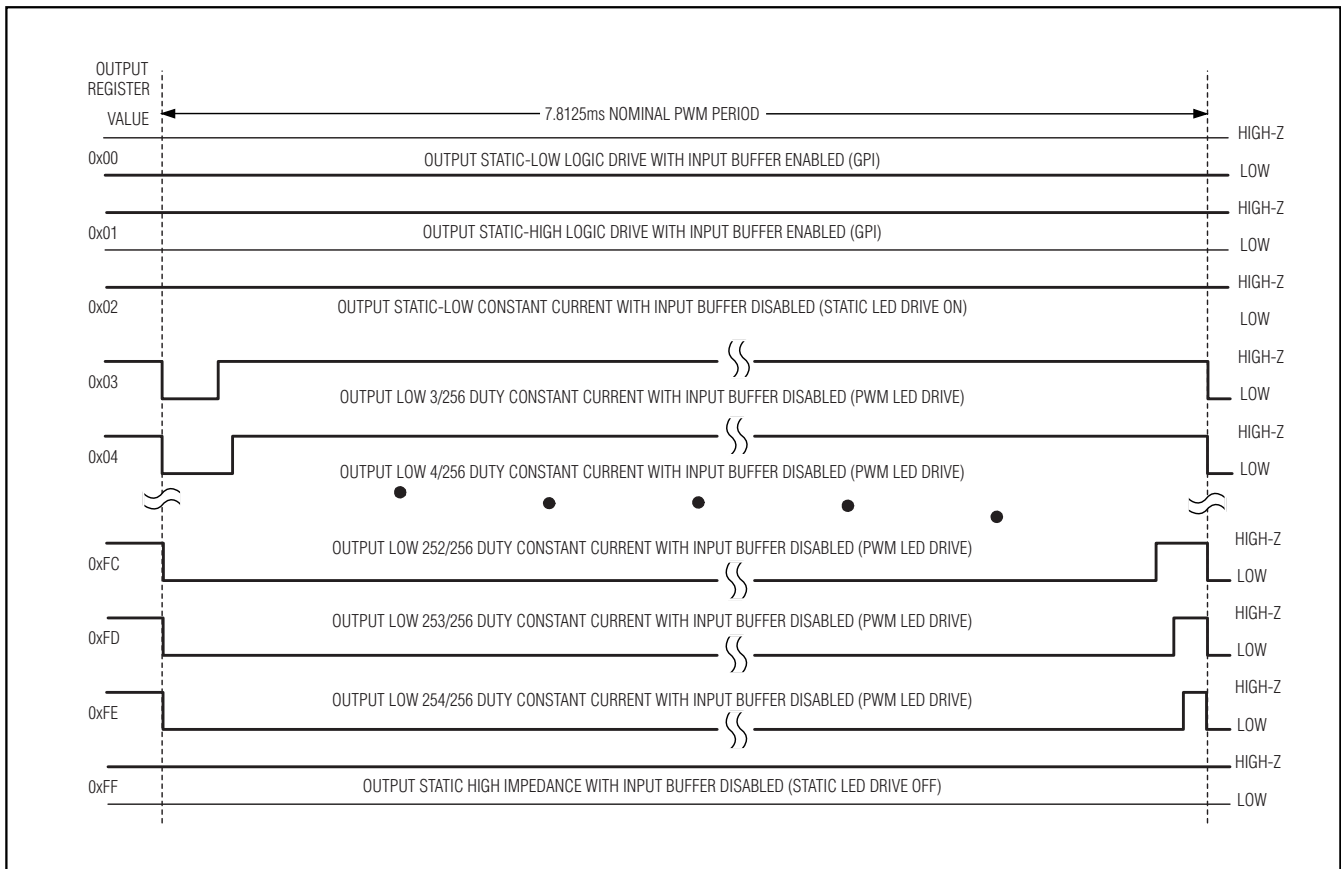

Figure 2. Static and PWM Constant-Current Waveforms

10-Port, Constant-Current LED Driver and I/O Expander with PWM Intensity Control

Ports Configured as Inputs

Configure a port as a logic input by writing 0x01 to the port's output register (Table 4). Reading an input port register returns the logic levels from the I/O ports configured as a logic input (Table 7). The input port register returns logic 0 in the appropriate bit position for a port not configured as a logic input.

The input port's registers are read only. The MAX6946/MAX6947 ignore a write to input ports register.

RST Input

The active-low $\overline{\text{RST}}$ input operates as a reset that voids any current I²C transaction involving the MAX6946/MAX6947, forcing the devices into the I²C stop condition. Use the D6 bit in the configuration register to configure $\overline{\text{RST}}$ to reset all the internal registers to the power-on reset state (Tables 2 and 3). The $\overline{\text{RST}}$ input is overvoltage tolerant to 6V.

The MAX6946/MAX6947 ignore all I²C bus activity while $\overline{\text{RST}}$ remains low. The MAX6946/MAX6947 use this feature to minimize supply current in power-critical applications by effectively disconnecting the MAX6946/MAX6947 from the bus during idle periods. $\overline{\text{RST}}$ also operates as a bus multiplexer, allowing multiple MAX6946/MAX6947s to use the same I²C slave address. Drive only one MAX6946/MAX6947 $\overline{\text{RST}}$ input high at any time to use $\overline{\text{RST}}$ as a bus multiplexer.

The MAX6946/MAX6947 feature a Reset Run option so that simply taking the $\overline{\text{RST}}$ input high brings the driver out of shutdown in addition to its normal function of enabling the devices' I²C interface.

Standby Mode and Operating Current

Configuring all the ports as logic inputs or outputs (all output registers set to value 0x00 or 0x01) or LED off (output register set to value 0xFF) puts the MAX6946/MAX6947 into standby mode. Put the MAX6946/MAX6947 into standby mode for lowest supply-current consumption.

Setting a port as a constant-current output increases the operating current (output register set to a value between 0x02 and 0xFE), even if a load is not applied to the port. The MAX6946/MAX6947 enable an internal current mirror to provide the accurate constant-current sink. Enabling the internal current mirror increases the devices' supply current. Each output contains a gated mirror, and each mirror is only enabled when required. In PWM mode, the current mirror is only turned on for the output's on-time. This means that the operating current varies as constant-current outputs are turned on and off through the serial interface, as well as by the PWM intensity control.

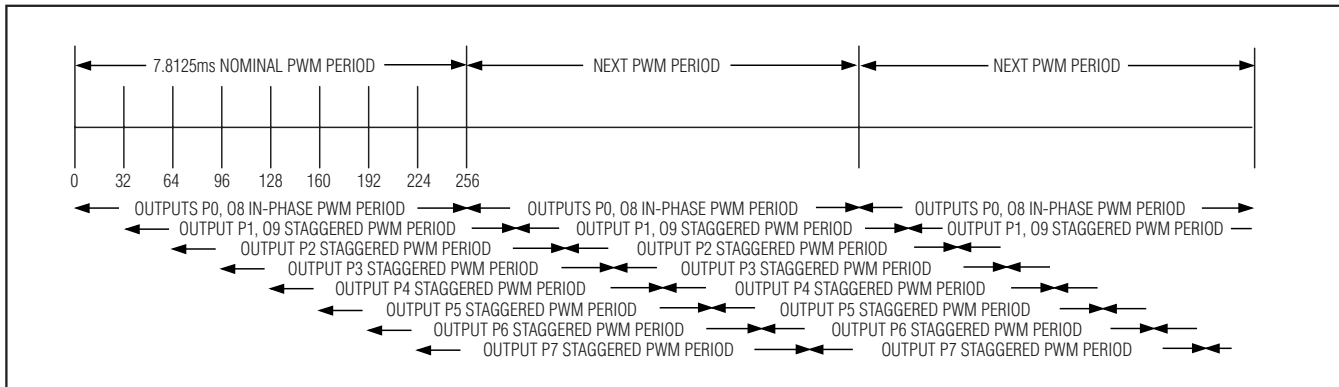

Figure 3. Staggered PWM Waveform

Table 7. Input Ports Registers

DESCRIPTION	ADDRESS CODE (HEX)	REGISTER BIT							
		D7	D6	D5	D4	D3	D2	D1	D0
Input ports P7–P0	0x0E	Port P7	Port P6	Port P5	Port P4	Port P3	Port P2	Port P1	Port P0
Input ports P9 and P8	0x0F	0	0	0	0	0	0	Port P9	Port P8

10-Port, Constant-Current LED Driver and I/O Expander with PWM Intensity Control

Shutdown Mode

In shutdown mode, all ports configured as constant-current outputs (output register set to a value between 0x02 and 0xFE) are switched off, and these outputs go high impedance as if their registers were set to value 0xFF. Ports configured as logic inputs or outputs (output registers set to value 0x00 or 0x01) are unaffected (Table 4). This means that any ports used for GPIOs are still fully operational in shutdown mode, and port inputs can be read and output ports can be toggled at any time using the serial interface. Use the MAX6946/MAX6947 for a mix of logic inputs, logic outputs, and PWM LED drivers, and only the LED drivers turn off automatically in shutdown.

Put the MAX6946/MAX6947 into shutdown mode by clearing the run bit (bit D0) in the configuration register (0x10) (Table 2). Exit shutdown by setting the run bit high through the serial interface or by using the Reset Run option (see the *Reset Run Option* section). Configure and control the MAX6946/MAX6947 normally through the serial interface in shutdown mode. All registers are accessible in shutdown mode, and shutdown mode does not change any register values.

Changing a port from static logic-low (0x00) or static logic-high (0x01) to a constant-current value (0x02–0xFE) in shutdown mode turns that output off (logic-high or high impedance) like any other constant-current outputs in shutdown. The new constant-current output starts just like any other constant-current outputs when exiting shutdown.

Changing a port from a constant-current value (0x02–0xFE) to static logic-low (0x00) or static logic-high (0x01) in shutdown causes that output to set to the value as a GPIO output. The new GPIO output is unaffected just like any other GPIO output when exiting shutdown.

Ramp-Up and Ramp-Down Controls

The MAX6946/MAX6947 provide controls that allow the output currents to ramp down into shutdown (ramp-down), and ramp up again out of shutdown (ramp-up) (Figures 4 and 5). Ramp-down comprises a programmable hold-off delay that also maintains the outputs at full current for a time before the programmed fade-off time. After the hold-off delay, the output currents ramp down.

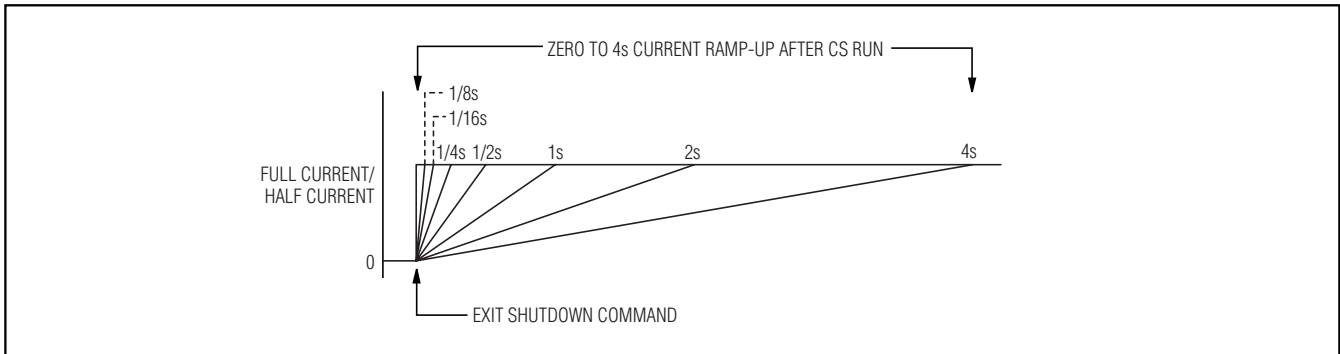

Figure 4. Ramp-Up Behavior

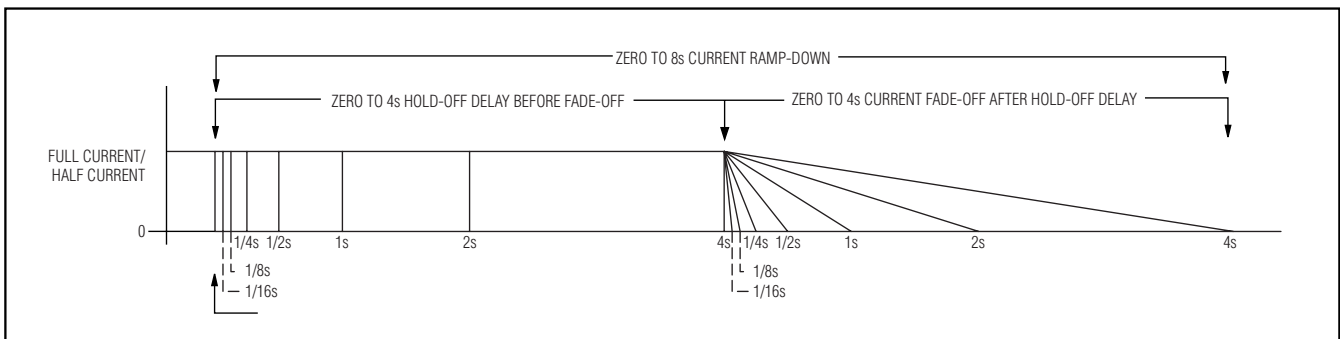

Figure 5. Ramp-Down, Hold-Off, and Fade-Off Behavior

10-Port, Constant-Current LED Driver and I/O Expander with PWM Intensity Control

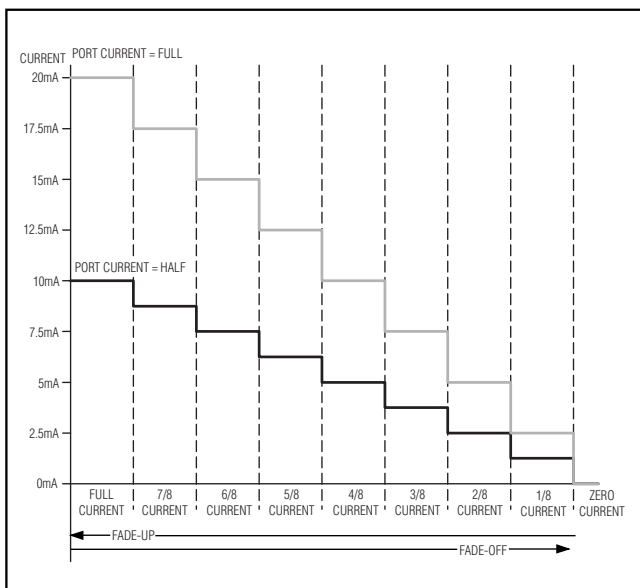

Figure 6. Output Fade DAC (Global Current = 0x07)

The ramp-down register sets the hold-off and fade-off times and allows disabling of hold-off and fade-off (zero delay), if desired (Table 8). The ramp-up register sets the ramp-up time and allows disabling of ramp-up (zero delay), if desired (Table 9). The configuration register contains three status bits that identify the condition of the MAX6946/MAX6947, hold-off, fade-off, or ramp-up (Table 2). The configuration register also enables or disables ramp-up. One write command to the configuration register can put the MAX6946/MAX6947 into shutdown (using hold-off and fade-off settings in the fade register) and one read command to the configuration register can determine whether the Reset Run is enabled for restart, and whether the MAX6946/MAX6947 will use ramp-up on restart.

Table 8. Ramp-Down Register Format (0X11)

DESCRIPTION	REGISTER BIT							
	D7	D6	D5	D4	D3	D2	D1	D0
Instant going into shutdown after hold-off delay	X	X	X	X	X	0	0	0
1/16s ramp-down from full current before shutdown after hold-off delay	X	X	X	X	X	0	0	1
1/8s ramp-down from full current before shutdown after hold-off delay	X	X	X	X	X	0	1	0
1/4s ramp-down from full current before shutdown after hold-off delay	X	X	X	X	X	0	1	1
1/2s ramp-down from full current before shutdown after hold-off delay	X	X	X	X	X	1	0	0
1s ramp-down from full current before shutdown after hold-off delay	X	X	X	X	X	1	0	1
2s ramp-down from full current before shutdown after hold-off delay	X	X	X	X	X	1	1	0
4s ramp-down from full current before shutdown after hold-off delay	X	X	X	X	X	1	1	1
Zero hold-off delay before fade-off going into shutdown	X	X	0	0	0	X	X	X
1/16s hold-off delay before fade-off going into shutdown	X	X	0	0	1	X	X	X
1/8s hold-off delay before fade-off going into shutdown	X	X	0	1	0	X	X	X
1/4s hold-off delay before fade-off going into shutdown	X	X	0	1	1	X	X	X
1/2s hold-off delay before fade-off going into shutdown	X	X	1	0	0	X	X	X
1s hold-off delay before fade-off going into shutdown	X	X	1	0	1	X	X	X
2s hold-off delay before fade-off going into shutdown	X	X	1	1	0	X	X	X
4s hold-off delay before fade-off going into shutdown	X	X	1	1	1	X	X	X

10-Port, Constant-Current LED Driver and I/O Expander with PWM Intensity Control

Table 9. Ramp-Up Register Format (0x12)

DESCRIPTION	REGISTER BIT							
	D7	D6	D5	D4	D3	D2	D1	D0
Instant full current coming out from shutdown	X	X	X	X	X	0	0	0
1/16s ramp-up to full current coming out from shutdown	X	X	X	X	X	0	0	1
1/8s ramp-up to full current coming out from shutdown	X	X	X	X	X	0	1	0
1/4s ramp-up to full current coming out from shutdown	X	X	X	X	X	0	1	1
1/2s ramp-up to full current coming out from shutdown	X	X	X	X	X	1	0	0
1s ramp-up to full current coming out from shutdown	X	X	X	X	X	1	0	1
2s ramp-up to full current coming out from shutdown	X	X	X	X	X	1	1	0
4s ramp-up to full current coming out from shutdown	X	X	X	X	X	1	1	1

Ramp-up and ramp-down use the PWM clock for timing. When using the external oscillator make sure the oscillator runs until the end of the sequence. The internal oscillator always runs during a fade sequence, even if none of the ports use PWM.

The ramp-up and ramp-down circuit operates a 3-bit DAC. The DAC adjusts the internal current reference used to set the constant-current outputs in a similar manner to the global-current register (Table 5). The MAX6946/MAX6947 scale the master current reference so all output constant-current and PWM settings adjust at the same ratio with respect to each other. This means the LEDs always fade at the same rate even if with different intensity settings.

The maximum port output current set by the global-current register (Table 5) also sets the point during ramp-down that the current starts falling, and the point during ramp-up that the current stops rising. Figure 7 shows the ramp waveforms that occur with different global-current register settings.

Reset Run Option

The MAX6946/MAX6947 feature a Reset Run option so that simply taking the \overline{RST} input high brings the driver out of shutdown in addition to its normal function of enabling the MAX6946/MAX6947s' I²C interface. This provides an alternative method of bringing the driver out of shutdown to writing to the configuration register through the serial interface. The Reset Run timing uses the PWM clock, either the internal nominal 32kHz oscillator or a user-provided clock fed into the OSC input (MAX6946 only).

After enabling the Reset Run option, the MAX6946/MAX6947 use the rising edge on \overline{RST} , followed by no I²C interface activity to the MAX6946/MAX6947 for 128 to 129 periods of the PWM clock to trigger the Reset

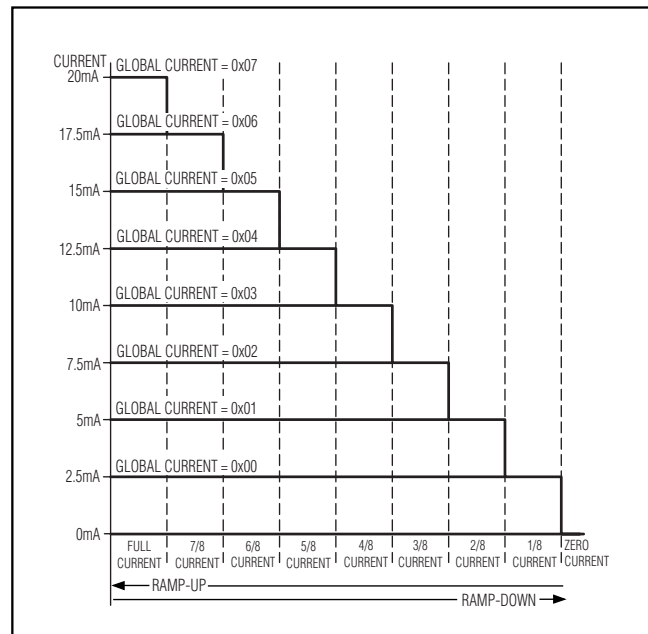

Figure 7. Global Current Modifies Fade Behavior

Run option. If this timeout period elapses without the MAX6946/MAX6947 acknowledging an I²C transaction, the run bit (D0) in the configuration register sets, bringing the driver out of shutdown and activating any programmed ramp-up. If \overline{RST} pulses high for less than this timeout period to trigger a Reset Run, the MAX6946/MAX6947 ignore the pulse, and the MAX6946/MAX6947 continue to wait for a suitable trigger.

Cancel the Reset Run trigger by transmitting an I²C communication to the MAX6946/MAX6947 before the timeout period elapses. The trigger cancels when the MAX6946/MAX6947 acknowledge the I²C transaction

10-Port, Constant-Current LED Driver and I/O Expander with PWM Intensity Control

and requires sending at least the MAX6946/MAX6947's I²C slave address. When using the internal oscillator, the minimum timeout period is 127/45000 equal to 2.822ms. When using an external oscillator for the PWM clock, the timeout period is 127/OSC. The shortest time period allowed is 1.27ms; this number corresponds to the maximum OSC frequency of 100kHz. When using the internal oscillator, the minimum I²C clock speed that guarantees a successful start bit and eight data bits (9 bits total) within the minimum timeout period is 9/5.66ms equal to 1590Hz. Canceling the Reset Run trigger clears the Reset Run bit (D1) in the configuration register, disabling Reset Run. The run bit (D0) in the configuration register remains cleared, so the driver remains in shutdown.

OSC Input

The MAX6946 can use an external clock of up to 100kHz instead of the internal 32kHz oscillator. Connect the external clock to the OSC input and set the OSC bit in the configuration register to enable the MAX6946 to use the external clock (Table 2).

Serial Interface

Serial Addressing

The MAX6946/MAX6947 operate as a slave that sends and receives data through an I²C-compatible, 2-wire interface. The interface uses a serial-data line (SDA) and a serial-clock line (SCL) to achieve bidirectional communication between master(s) and slave(s). A master (typically a microcontroller) initiates all data transfers to and from the MAX6946/MAX6947 and generates the SCL clock that synchronizes the data transfer (Figure 8).

The MAX6946/MAX6947 SDA line operates as both an input and an open-drain output. A pullup resistor, typically 4.7k Ω , is required on SDA. The MAX6946/MAX6947 SCL line operates as an input. A pullup resistor, typically 4.7k Ω , is required on SCL if there are multiple masters on the 2-wire interface, or if the master in a single-master system has an open-drain SCL output.

Each transmission consists of a START condition (Figure 9) sent by a master, followed by the MAX6946/MAX6947 7-bit slave address plus the R/W bit, a register address byte, one or more data bytes, and finally a STOP condition (Figure 9).

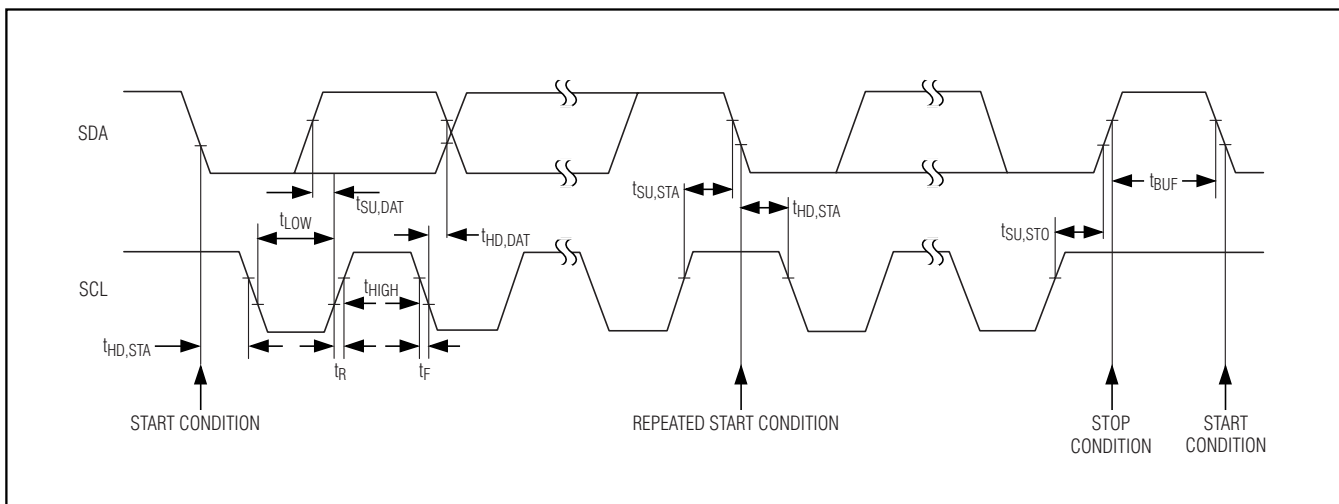

Figure 8. 2-Wire Serial Interface Timing Details

10-Port, Constant-Current LED Driver and I/O Expander with PWM Intensity Control

Table 10. MAX6946/MAX6947 Slave Addresses

MAX6947	SLAVE ADDRESS
AD0 = GND	010 0000
AD0 = V _{DD}	010 0100
MAX6946	010 0000

Start and Stop Conditions

Both SCL and SDA remain high when the interface is not busy. A master signals the beginning of a transmission with a START (S) condition by transitioning SDA from high to low while SCL is high. When the master finishes communicating with the slave, it issues a STOP (P) condition by transitioning SDA from low to high while SCL is high. The bus is then free for another transmission (Figure 9).

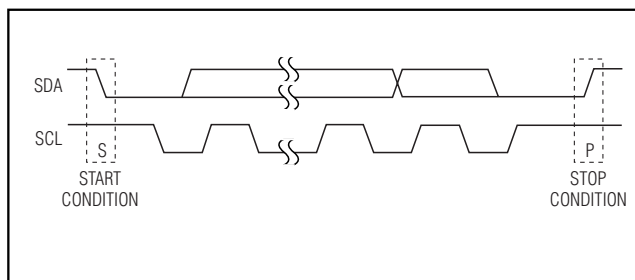

Figure 9. Start and Stop Conditions

Bit Transfer

One data bit is transferred during each clock pulse. The data on SDA must remain stable while SCL is high (Figure 10).

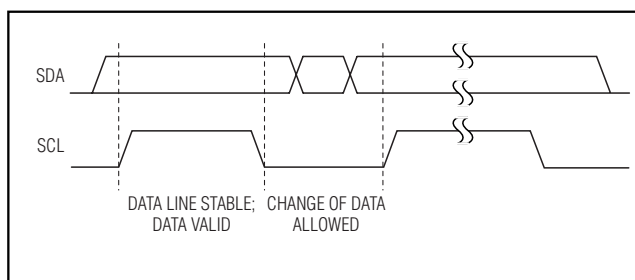

Figure 10. Bit Transfer

Acknowledge

Any bytes received after the command byte are data bytes. The first data byte goes into the internal register of the MAX6946/MAX6947 selected by the command byte (Figure 11). If multiple data bytes are transmitted before a STOP condition is detected, these bytes are generally stored in subsequent MAX6946/MAX6947 internal registers because the command byte autoincrements (Table 1).

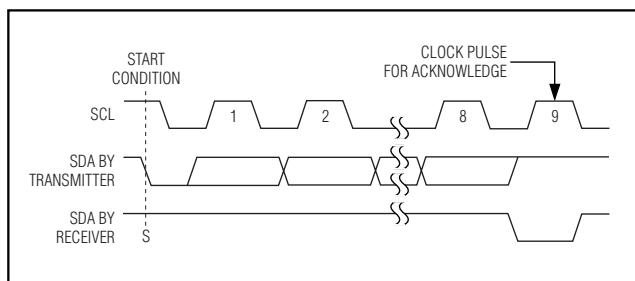

Figure 11. Acknowledge

Message Format for Reading

Read from the MAX6946/MAX6947 using the MAX6946/MAX6947s' internally stored command byte as an address pointer the same way the stored command byte is used as an address pointer for a write. The pointer autoincrements after each data byte is read using the same rules as for a write (Table 1). Thus, a read is initiated by first configuring the MAX6946/MAX6947s' command byte by performing a write (Figures 12 and 13). The master can now read n con-

secutive bytes from the MAX6946/MAX6947 with the first data byte being read from the register addressed by the initialized command byte (Figure 14). When performing read-after-write verification, remember to reset the command byte's address because the stored command byte address has been autoincremented after the write (Table 1).

10-Port, Constant-Current LED Driver and I/O Expander with PWM Intensity Control

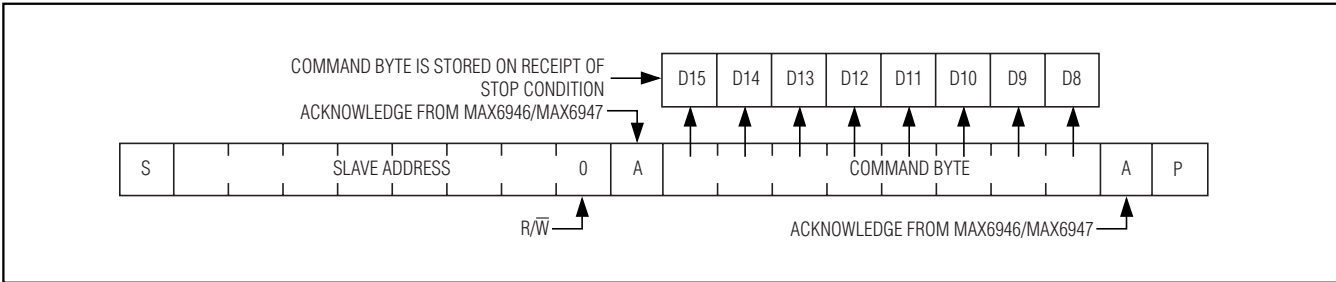

Figure 12. Command Byte Received

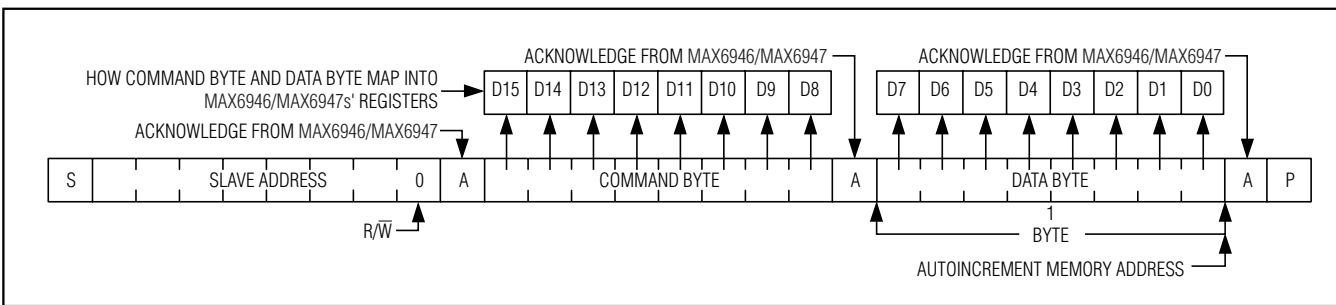

Figure 13. Command and Single Data Byte Received

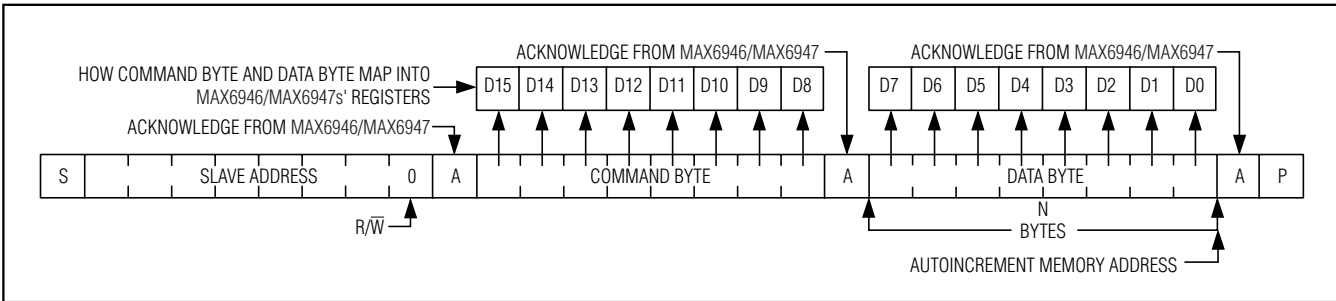

Figure 14. n Data Bytes Received

Operation with Multiple Masters

If the MAX6946/MAX6947 operates on a 2-wire interface with multiple masters, a master reading the MAX6946/MAX6947 should use a repeated start between the read and write. This sets the MAX6946/MAX6947 address pointer, and the read(s) that takes the data from the location(s) (Table 1). This is because it is possible for master 2 to take over the bus after master 1 has set up the MAX6946/MAX6947s' address pointer, then master 1's delayed read can be from an unexpected location.

Command Address Autoincrementing

The command address stored in the MAX6946/MAX6947 increments through the grouped register functions after each data byte is written or read (Table 1).

Applications Information

Port Input and I²C Interface-Level Translation from Higher or Lower Logic Voltages

The MAX6946/MAX6947s' I²C interface (SDA, SCL) and I²C slave address select input AD0 (MAX6947 only), PWM clock input OSC (MAX6946 only), and reset input RST are overvoltage protected to +6V, independent of V_{DD}. The 10 I/O ports P0–P9 are overvoltage protected to +8V independent of V_{DD}. This allows the MAX6946/MAX6947 to operate from one supply voltage, such as 3.3V, while driving the I²C interface and/or some of the 10 I/O as inputs from a higher logic level, such as 5V.

10-Port, Constant-Current LED Driver and I/O Expander with PWM Intensity Control

Hot Insertion

The $\overline{\text{RST}}$, SCL, and AD0 inputs and SDA remain high impedance with up to +6V asserted on them when the MAX6946/MAX6947 power down ($V_{\text{DD}} = 0\text{V}$). I/O ports P0 to P9 remain high impedance with up to +8V asserted on them when the MAX6946/MAX6947 power down. Use the MAX6946/MAX6947 in hot-swap applications.

Differences Between the MAX6946 and MAX6947

The MAX6946 features the OSC input, allowing the device to use an external clock as the PWM clock source. The MAX6946 features a fixed I²C slave address of 0100000. The MAX6947 features an AD0 input, allowing two unique I²C addresses (Table 10). The MAX6947 always uses the internal 32kHz oscillator as the PWM clock source.

Driving LEDs into Brownout

The MAX6946/MAX6947 correctly regulate the constant-current outputs, provided there is a minimum voltage drop across the port output. This port output voltage is the difference between the load (typically LED) supply and the load voltage drop (LED forward voltage). If the LED supply drops so that the minimum port output voltage is not maintained, the driver output stages brownout and the load current falls. The minimum port voltage is approximately 0.5V at 10mA sink current and approximately 1V at 20mA sink current.

Operating the LEDs directly from a battery supply can cause brownouts. For example, the LED supply voltage is a single rechargeable lithium-ion battery with a maximum terminal voltage of 4.2V on charge, 3.4V to 3.7V

most of the time, and down to 3V when discharged. In this scenario, the LED supply falls significantly below the brownout point when the battery is at end-of-life voltage (3V).

Figure 15 shows the typical current sink by a LITEON LTST-C170TBKT 3.0V blue LED as the LED supply voltage is varied from 2.5V to 7V. The LED currents shown are for ports programmed for 10mA and 20mA constant current, swept over a 2.5V to 7V LED supply voltage range. It can be seen that the LED forward voltage falls with current, allowing the LED current to fall gracefully, not abruptly, in brownout. In practice, the LED current drops to 6mA to 7mA at a 3V LED supply voltage, this is acceptable performance at end-of-life in many back-light applications.

Output-Level Translation

The open-drain output architecture allows the ports to level translate the outputs to higher or lower voltages than the MAX6946/MAX6947 supply. Use an external pullup resistor on any output to convert the high-impedance, logic-high condition to a positive voltage level. Connect the resistor to any voltage up to 7V. When using a pullup on a constant-current output, select the resistor value to sink no more than a few hundred micamps in logic-low condition. This ensures that the current sink output saturates close to GND. For interfacing CMOS inputs, a pullup resistor value of 220k Ω is a good starting point. Use a lower resistance to improve noise immunity in applications where power consumption is less critical, or where a faster rise time is needed for a given capacitive load.

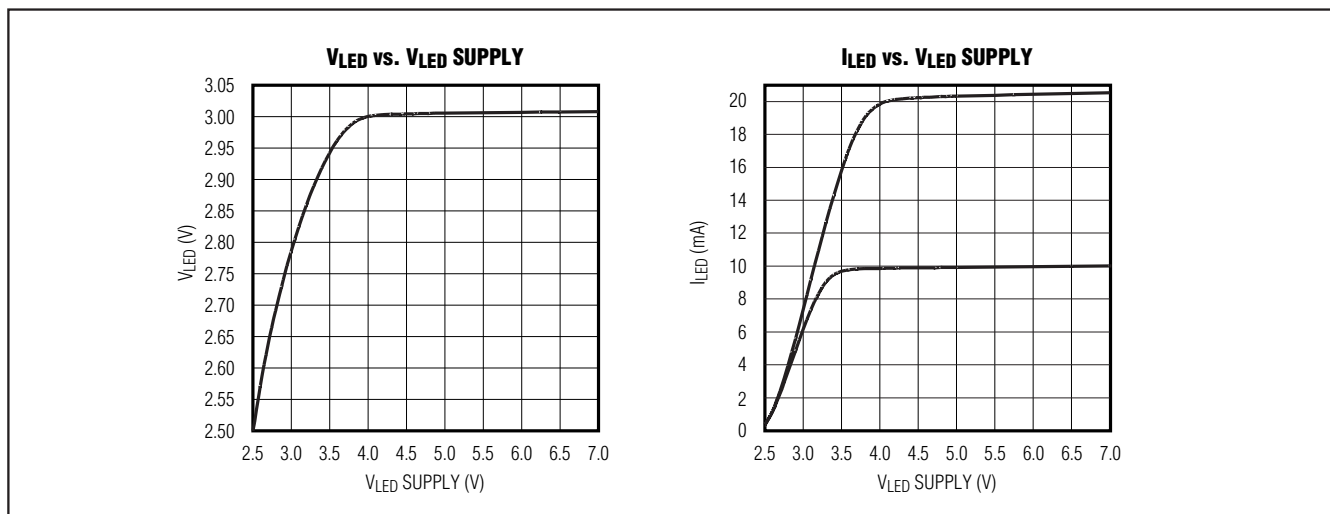

Figure 15. LED Brownout

10-Port, Constant-Current LED Driver and I/O Expander with PWM Intensity Control

Using Stagger with Fewer Ports

The stagger option, when selected, applies to all ports configured as constant-current outputs. The 10 ports' PWM cycles are separated to eight evenly spaced start positions (Figure 3). Optimize phasing when using fewer than 10 ports as constant-current outputs by allocating the ports with the most appropriate start positions. If using eight constant-current outputs, choose P0–P7 because these all have different PWM start positions. If using four constant-current outputs, choose P0, P2, P4, P6 or P1, P3, P5, P7 because their PWM start positions are evenly spaced. In general, choose the ports that spread the PWM start positions as evenly as possible. This optimally spreads out the current demand from the ports' load supply.

Generating a Shutdown/Run Output

The MAX6946/MAX6947 can use an I/O port to automatically generate a shutdown/run output. The shutdown/run output is active low when the MAX6946/MAX6947 are in run mode, hold-off, fade-off, or ramp-up, and goes high automatically when the devices finally enter shutdown after fade-off. Programming the port's output register to value 0x02 puts the output into static constant-current mode (Table 4). Program the port's output current register to half current (Table 6) to minimize operating current. Connect a 220kΩ pullup resistor to this port.

In run mode, the output port goes low, approaching 0V, as the port's static constant current saturates trying to sink a higher current than the 220kΩ pullup resistor can source.

In shutdown mode, the output goes high impedance together with any other constant-current outputs. This output remains low during ramp-up and fade-down sequences because the current drawn by the 220kΩ pullup resistor is much smaller than the available output constant current, even at the lowest fade current step.

Driving Load Currents Higher than 20mA

The MAX6946/MAX6947 can drive loads needing more than 20mA, like high-current white LEDs, by paralleling outputs. For example, consider a white LED that requires 70mA. Drive this LED using the ports P0–P3 connected in parallel (shorted together). Configure three of the ports for full current (20mA) and configure the last port for half current (10mA) to meet the 70mA requirement. Control the four ports simultaneously with one write access using register 0x0B (Table 1). Note that because the output ports are current limiting, they do not need to switch simultaneously to ensure safe current sharing.

Power-Supply Considerations

The MAX6946/MAX6947 operate with a power-supply voltage of 2.25V to 3.6V. Bypass the power supply to GND with a 0.1μF ceramic capacitor as close as possible to the device.

Chip Information

PROCESS: BICMOS

Pin Configurations (continued)

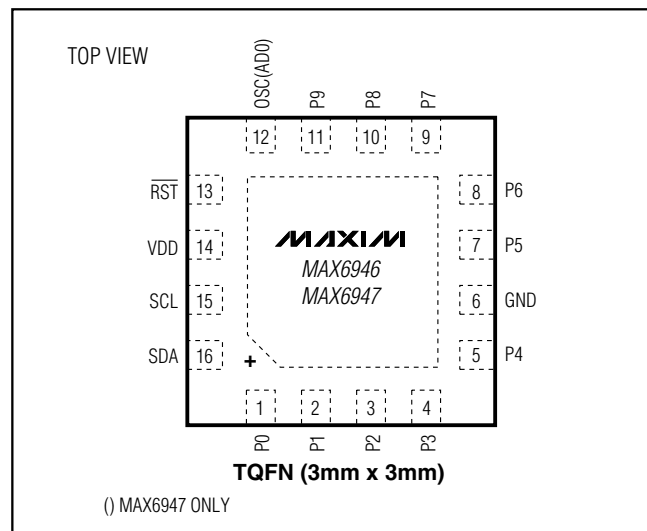

10-Port, Constant-Current LED Driver and I/O Expander with PWM Intensity Control

Package Information

(The package drawing(s) in this data sheet may not reflect the most current specifications. For the latest package outline information, go to www.maxim-ic.com/packages.)

MAX6946/MAX6947

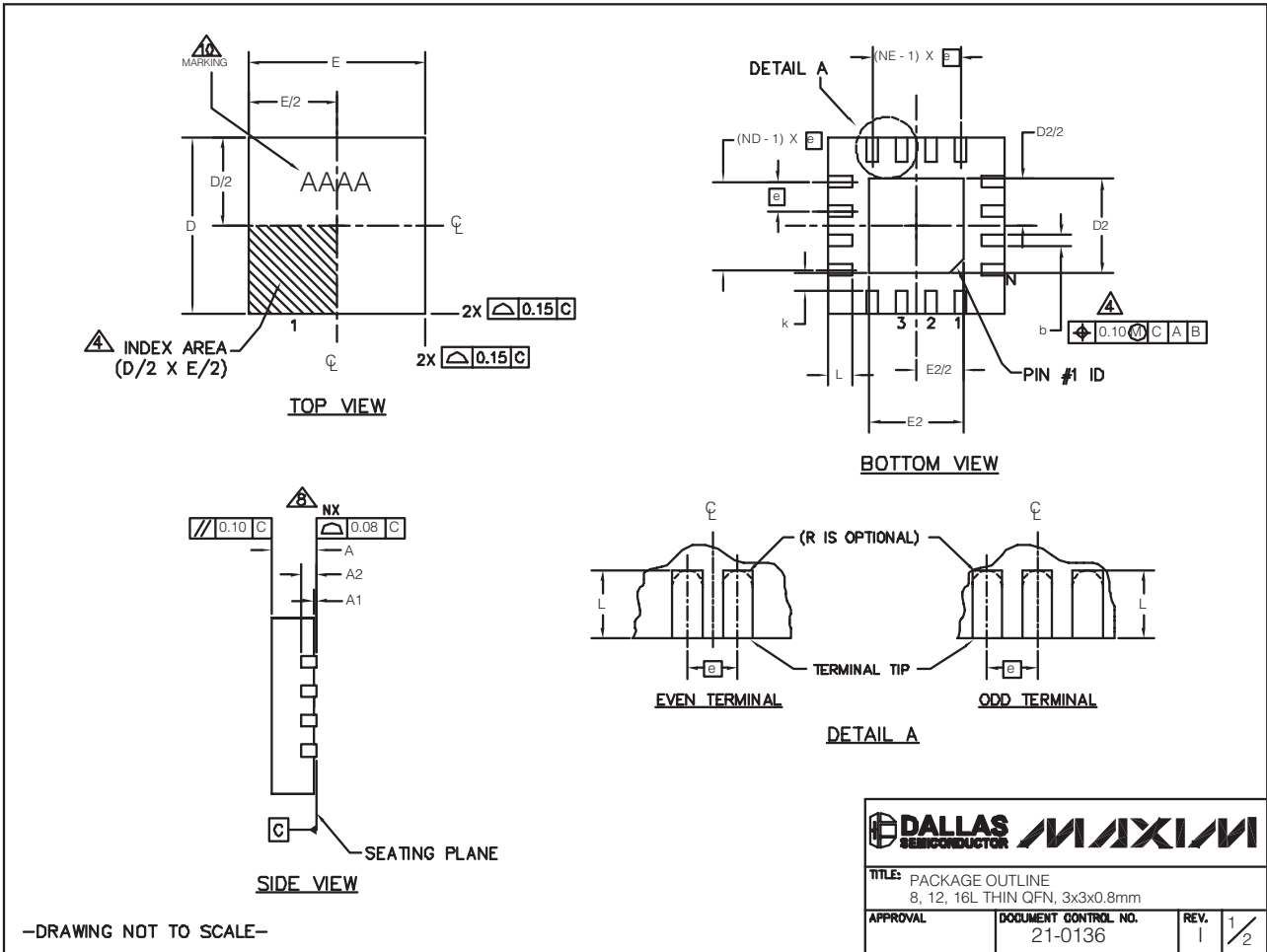

10-Port, Constant-Current LED Driver and I/O Expander with PWM Intensity Control

Package Information (continued)

(The package drawing(s) in this data sheet may not reflect the most current specifications. For the latest package outline information, go to www.maxim-ic.com/packages.)

PKG	8L 3x3			12L 3x3			16L 3x3		
REF.	MIN.	NOM.	MAX.	MIN.	NOM.	MAX.	MIN.	NOM.	MAX.
A	0.70	0.75	0.80	0.70	0.75	0.80	0.70	0.75	0.80
b	0.25	0.30	0.35	0.20	0.25	0.30	0.20	0.25	0.30
D	2.90	3.00	3.10	2.90	3.00	3.10	2.90	3.00	3.10
E	2.90	3.00	3.10	2.90	3.00	3.10	2.90	3.00	3.10
e	0.65 BSC.			0.50 BSC.			0.50 BSC.		
L	0.35	0.55	0.75	0.45	0.55	0.65	0.30	0.40	0.50
N	8			12			16		
ND	2			3			4		
NE	2			3			4		
A1	0	0.02	0.05	0	0.02	0.05	0	0.02	0.05
A2	0.20 REF			0.20 REF			0.20 REF		
k	0.25	-	-	0.25	-	-	0.25	-	-

PKG. CODES	D2			E2			PIN ID	JEDEC
	MIN.	NOM.	MAX.	MIN.	NOM.	MAX.		
TQ833-1	0.25	0.70	1.25	0.25	0.70	1.25	0.35 x 45°	WEEC
T1233-1	0.95	1.10	1.25	0.95	1.10	1.25	0.35 x 45°	WEED-1
T1233-3	0.95	1.10	1.25	0.95	1.10	1.25	0.35 x 45°	WEED-1
T1233-4	0.95	1.10	1.25	0.95	1.10	1.25	0.35 x 45°	WEED-1
T1633-2	0.95	1.10	1.25	0.95	1.10	1.25	0.35 x 45°	WEED-2
T1633F-3	0.65	0.80	0.95	0.65	0.80	0.95	0.225 x 45°	WEED-2
T1633FH-3	0.65	0.80	0.95	0.65	0.80	0.95	0.225 x 45°	WEED-2
T1633-4	0.95	1.10	1.25	0.95	1.10	1.25	0.35 x 45°	WEED-2
T1633-5	0.95	1.10	1.25	0.95	1.10	1.25	0.35 x 45°	WEED-2

NOTES:

1. DIMENSIONING & TOLERANCING CONFORM TO ASME Y14.5M-1994.
2. ALL DIMENSIONS ARE IN MILLIMETERS. ANGLES ARE IN DEGREES.
3. N IS THE TOTAL NUMBER OF TERMINALS.
4. THE TERMINAL #1 IDENTIFIER AND TERMINAL NUMBERING CONVENTION SHALL CONFORM TO JESD 95-1 SPP-012. DETAILS OF TERMINAL #1 IDENTIFIER ARE OPTIONAL, BUT MUST BE LOCATED WITHIN THE ZONE INDICATED. THE TERMINAL #1 IDENTIFIER MAY BE EITHER A MOLD OR MARKED FEATURE.
5. DIMENSION b APPLIES TO METALLIZED TERMINAL AND IS MEASURED BETWEEN 0.20 mm AND 0.25 mm FROM TERMINAL TIP.
6. ND AND NE REFER TO THE NUMBER OF TERMINALS ON EACH D AND E SIDE RESPECTIVELY.
7. DEPOPULATION IS POSSIBLE IN A SYMMETRICAL FASHION.
8. COPLANARITY APPLIES TO THE EXPOSED HEAT SINK SLUG AS WELL AS THE TERMINALS.
9. DRAWING CONFORMS TO JEDEC MO220 REVISION C.
10. MARKING IS FOR PACKAGE ORIENTATION REFERENCE ONLY.
11. NUMBER OF LEADS SHOWN ARE FOR REFERENCE ONLY.
12. WARPAGE NOT TO EXCEED 0.10mm.

-DRAWING NOT TO SCALE-

			
TITLE: PACKAGE OUTLINE 8, 12, 16L THIN QFN, 3x3x0.8mm			
APPROVAL	DOCUMENT CONTROL NO. 21-0136	REV. 1	2/2

10-Port, Constant-Current LED Driver and I/O Expander with PWM Intensity Control

Package Information (continued)

(The package drawing(s) in this data sheet may not reflect the most current specifications. For the latest package outline information, go to www.maxim-ic.com/packages.)

MAX6946/MAX6947

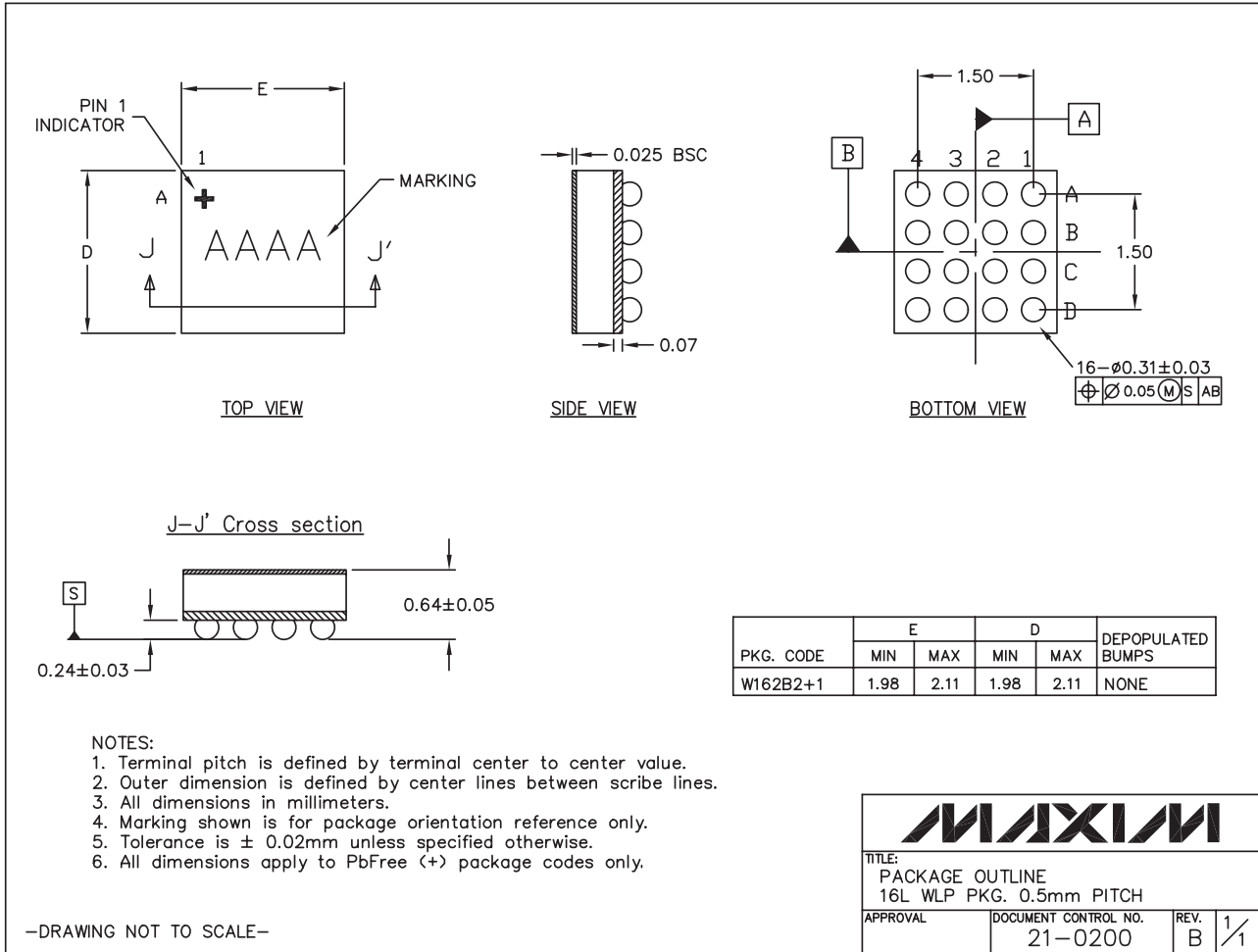

10-Port, Constant-Current LED Driver and I/O Expander with PWM Intensity Control

Revision History

REVISION NUMBER	REVISION DATE	DESCRIPTION	PAGES CHANGED
2	10/06	—	1, 7, 11, 17, 19
3	1/08	Added MAX6946C (WLP package) to the data sheet.	1-6, 20, 23

Maxim cannot assume responsibility for use of any circuitry other than circuitry entirely embodied in a Maxim product. No circuit patent licenses are implied. Maxim reserves the right to change the circuitry and specifications without notice at any time.

24 _____ **Maxim Integrated Products, 120 San Gabriel Drive, Sunnyvale, CA 94086 408-737-7600**

Looking for pricing, stock, or lifecycle information?

Click below to explore more details on WIN SOURCE:

 [View MAX6947ATE+ on WIN SOURCE](#)

 [Maxim Integrated](#) Information

Optimize Your Supply Chain with WIN SOURCE Solutions

-  Global Sourcing Solution
-  Obsolete Management
-  Cost Control Management
-  Shortage Management
-  Alternative Solution
-  Excess Inventory Management