



**THE DATASHEET OF
WT11I-E-AI5**



WT11i-E

DATA SHEET

Monday, 09 September 2013

Version 1.14



Copyright © 2000-2013 Bluegiga Technologies

All rights reserved.

Bluegiga Technologies assumes no responsibility for any errors which may appear in this manual. Furthermore, Bluegiga Technologies reserves the right to alter the hardware, software, and/or specifications detailed here at any time without notice and does not make any commitment to update the information contained here. Bluegiga's products are not authorized for use as critical components in life support devices or systems.

The WRAP is a registered trademark of Bluegiga Technologies

The *Bluetooth* trademark is owned by the Bluetooth SIG Inc., USA and is licensed to Bluegiga Technologies. All other trademarks listed herein are owned by their respective owners.

VERSION HISTORY

Version	Comment
1.13	MIC Japan certification information
1.12	FCC/IC SAR requirement
1.11	Peak current consumption corrected from 170 mA to 180 mA
1.1	Recommended PCB land pattern
1.06	External dimensions
1.05	FCC certification notice updated
1.04	Typo corrections
1.03	Page 33: Reset is active high
1.02	Package drawings added
1.01	Ordering information corrected
1.0	Release

TABLE OF CONTENTS

1	Ordering Information.....	7
2	Pinout and Terminal Description	8
3	Electrical Characteristics	11
3.1	Absolute Maximum Ratings	11
3.2	Recommended Operating Conditions	11
3.3	Current Consumption	11
3.4	PIO Current Sink and Source Capability.....	12
3.5	Antenna Specification	12
4	Physical Dimensions	13
4.1	Package Dimensions	14
5	Layout Guidelines.....	16
6	UART Interface.....	18
6.1	UART Bypass.....	20
6.2	UART Configuration While Reset is Active	20
6.3	UART Bypass Mode.....	20
7	USB Interface	21
7.1	USB Data Connections	21
7.2	USB Pull-Up resistor	21
7.3	USB Power Supply.....	21
7.4	Self-Powered Mode.....	21
7.5	Bus-Powered Mode.....	22
7.6	USB Suspend Current.....	23
7.7	USB Detach and Wake-Up Signaling.....	23
7.8	USB Driver	24
7.9	USB v2.0 Compliance and Compatibility	24
8	Serial Peripheral Interface (SPI).....	25
9	PCM Codec Interface	26
9.1	PCM Interface Master/Slave	26
9.2	Long Frame Sync.....	27
9.3	Short Frame Sync	27
9.4	Multi-slot Operation	28
9.5	GCI Interface	28
9.6	Slots and Sample Formats.....	29
9.7	Additional Features	30
9.8	PCM_CLK and PCM_SYNC Generation	30
9.9	PCM Configuration	31
10	I/O Parallel Ports.....	33

10.1	PIO Defaults.....	33
11	Reset.....	34
11.1	Pin States on Reset	34
12	Certifications	35
12.1	Bluetooth	35
12.2	FCC and IC	35
12.2.1	FCC et IC	37
12.3	CE	38
12.4	MIC Japan.....	39
12.5	Qualified Antenna Types for WT11i-E	40
13	Contact Information.....	41

DESCRIPTION

WT11i is a fully integrated *Bluetooth* 2.1 + EDR, class 1 module combining antenna, *Bluetooth* radio and an on-board iWRAP *Bluetooth* stack. Bluegiga WT11i provides an ideal solution for developers that want to quickly integrate long range and high performance *Bluetooth* wireless technology to their design without investing several months into *Bluetooth* radio and stack development. WT11i provides a 100dB link budget ensuring long range and robust *Bluetooth* connectivity. WT11i uses Bluegiga's iWRAP *Bluetooth* stack, which is an embedded *Bluetooth* stack implementing 13 different *Bluetooth* profiles and Apple iAP connectivity. By using WT11i combined with iWRAP *Bluetooth* stack and Bluegiga's excellent technical support designers ensure quick time to market, low development costs and risk.

APPLICATIONS:

- Industrial and M2M
- Point-of-Sale devices
- Computer Accessories

KEY FEATURES:**Radio features:**

- *Bluetooth* v.2.1 + EDR
- *Bluetooth* class 1 radio
- Transmit power: +17 dBm
- Receiver sensitivity: -86 dBm
- Range: 350 meters line-of-sight
- Integrated chip antenna or U.FL connector

Hardware features:

- UART and USB host interfaces
- 802.11 co-existence interface
- 6 software programmable IO pins
- Operating voltage: 2.7V to 3.6V
- Temperature range: -40C to +85C
- Dimensions: 35.75 x 14.50 x 2.6 mm

Qualifications:

- *Bluetooth*
- CE
- FCC
- IC
- Japan

PHYSICAL OUTLOOK

1 Ordering Information

	U.FL Connector	Internal chip antenna
iWRAP 5.0 firmware	WT11i-E-AI5	WT11i-A-AI5
iWRAP 4.0 firmware	WT11i-E-AI4	WT11i-A-AI4
iWRAP 3.0 firmware	WT11i-E-AI3	WT11i-A-AI3
HCI firmware, BT2.1 + EDR	WT11i-E-HCI21	WT11i-A-HCI21
Custom firmware	WT11i-E-C (*)	WT11i-A-C (*)

Table 1: Ordering information

**) Custom firmware means any standard firmware with custom parameters (like UART baud rate), custom firmware developer by customer or custom firmware developed by Bluegiga for the customer.*

To order custom firmware you must have a properly filled Custom Firmware Order Form and unique ordering code issued by Bluegiga.

Contact sales@bluegiga.com for more information.

2 Pinout and Terminal Description

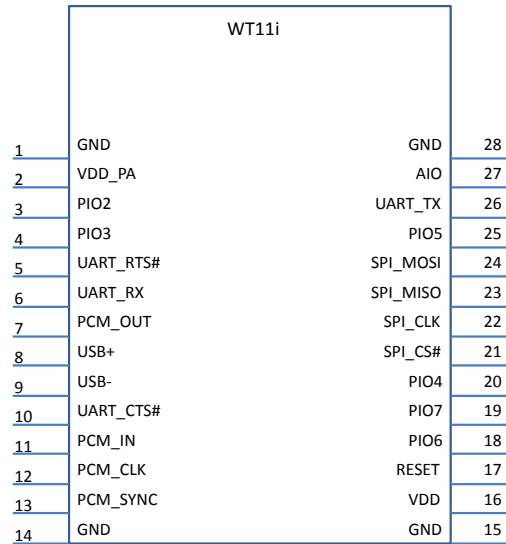

Figure 1: WT11i connection diagram

	PIN NUMBER	PAD TYPE	DESCRIPTION
RESET	17	Input, internal 220kohm pull-down, internal start up reset circuitry	Active high reset. Keep high for >5 ms to cause a reset
GND	1, 14, 15, 28	GND	GND
VDD_PA	2	Supply voltage	Supply voltage for the RF power amplifier
VDD	16	Supply voltage	Supply voltage for BC4 and the flash memory

Table 2: Supply and RF Terminal Descriptions

PIO PORT	PIN NUMBER	PAD TYPE	DESCRIPTION
PIO[2]	3	Bi-directional, programmable strength internal pull-down/pull-up	Programmable input/output line
PIO[3]	4	Bi-directional, programmable strength internal pull-down/pull-up	Programmable input/output line
PIO[4]	20	Bi-directional, programmable strength internal pull-down/pull-up	Programmable input/output line
PIO[5]	25	Bi-directional, programmable strength internal pull-down/pull-up	Programmable input/output line
PIO[6]	18	Bi-directional, programmable strength internal pull-down/pull-up	Programmable input/output line
PIO[7]	19	Bi-directional, programmable strength internal pull-down/pull-up	Programmable input/output line
AIO[1]	27	Bi-directional	Programmable analog input/output line

Table 3: GPIO Terminal Descriptions

SPI INTERFACE	PIN NUMBER	PAD TYPE	DESCRIPTION
PCM_OUT	7	CMOS output, tri-state, weak internal pull-down	Synchronous data output
PCM_IN	11	CMOS input, weak internal pull-down	Synchronous data input
PCM_SYNC	13	Bi-directional, weak internal pull-down	Synchronous data sync
PCM_CLK	12	Bi-directional, weak internal pull-down	Synchronous data clock

Table 4: PCM Terminal Descriptions

UART Interfaces	PIN NUMBER	PAD TYPE	DESCRIPTION
UART_TX	26	CMOS output, tri-state, with weak internal pull-up	UART data output, active high
UART_RTS#	5	CMOS output, tri-state, with weak internal pull-up	UART request to send, active low
UART_RX	6	CMOS input, tri-state, with weak internal pull-down	UART data input, active high
UART_CTS#	10	CMOS input, tri-state, with weak internal pull-down	UART clear to send, active low

Table 5: UART Terminal Descriptions

USB Interfaces	PIN NUMBER	PAD TYPE	DESCRIPTION
USB+	8	Bidirectional	USB data plus with selectable internal 1.5k pull-up resistor
USB-	9	Bidirectional	USB data minus

Table 6: USB Terminal Descriptions

SPI INTERFACE	PIN NUMBER	PAD TYPE	DESCRIPTION
SPI_MOSI	24	CMOS input with weak internal pull-down	SPI data input
SPI_CS#	21	CMOS input with weak internal pull-up	Chip select for Serial Peripheral Interface, active low
SPI_CLK	22	CMOS input with weak internal pull-down	SPI clock
SPI_MISO	23	CMOS output, tristate, with weak internal pull down	SPI data output

Table 7: Terminal Descriptions

3 Electrical Characteristics

3.1 Absolute Maximum Ratings

Rating	Min	Max	Unit
Storage Temperature	-40	85	°C
VDD_PA, VDD	-0.4	3.6	V
Other Terminal Voltages	VSS-0.4	VDD+0.4	V

Table 8: Absolute Maximum Ratings

3.2 Recommended Operating Conditions

Rating	Min	Max	Unit
Operating Temperature Range	-40	85	°C
VDD_PA, VDD ^{*)}	3.0	3.6	V

*) VDD_PA has an effect on the RF output power.

Table 9: Recommended Operating Conditions

3.3 Current Consumption

	Packet type	Power level	MAX	AVG	Unit
TX	DH1	17 dBm	180	72	mA
		12 dm	170	54	
	DH5	17 dBm	170	128	
		12 dm	170	84	
	2DH5	12 dm	106	93	
	3DH5	12 dm	106	93	
RX	-	-	-	39	
Sleep	-	-	-	50	µA
Inquiry	-	17 dBm		59	mA

Table 10: WT11i Current Consumption

3.4 PIO Current Sink and Source Capability

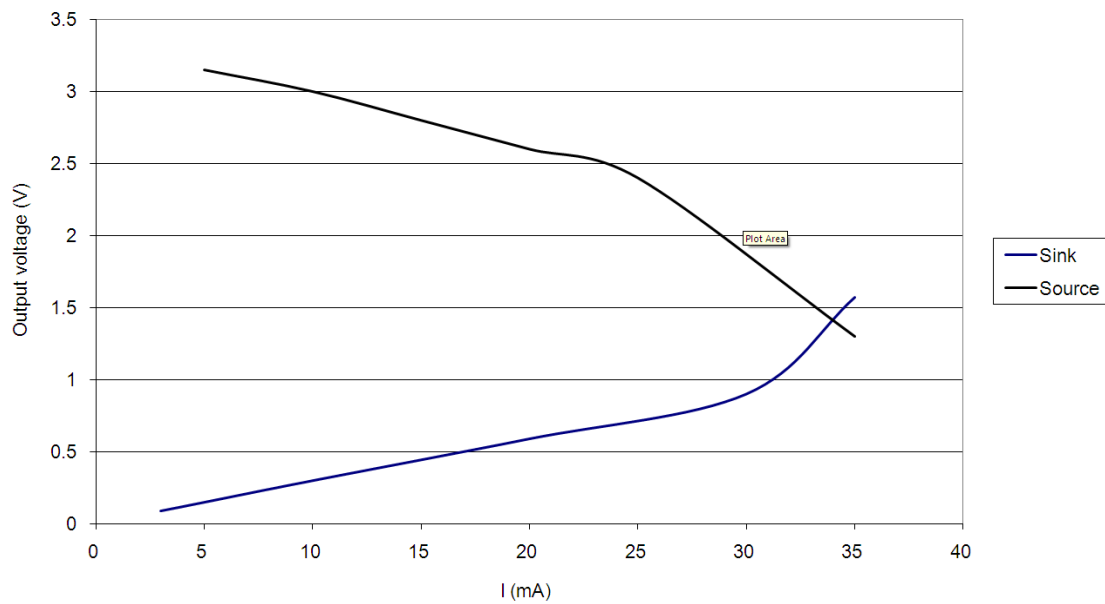

Figure 2: WT11i PIO Current Drive Capability

3.5 Antenna Specification

4 Physical Dimensions

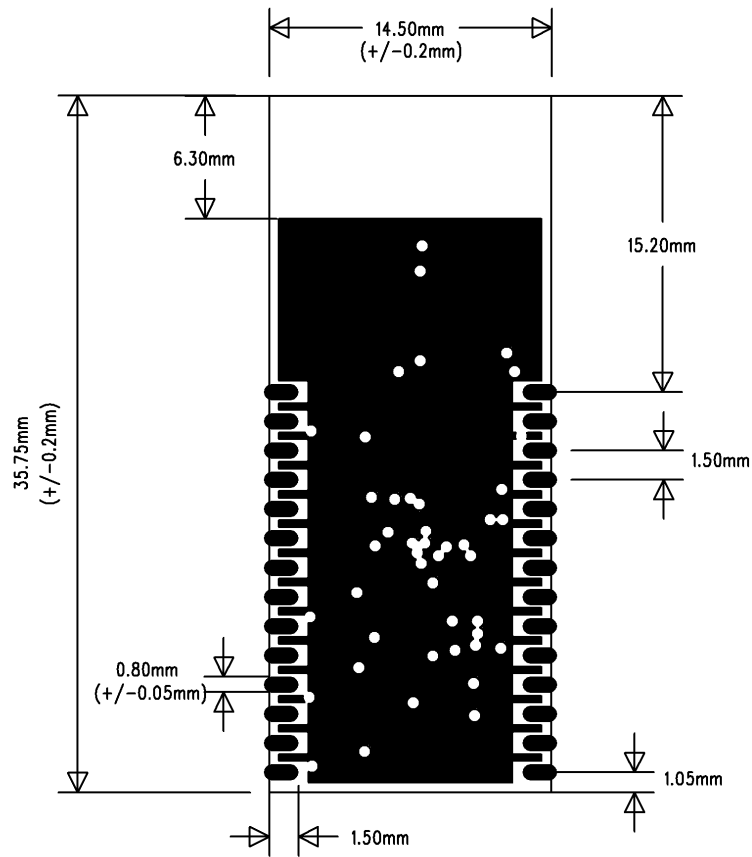

Figure 3: Physical dimensions (top view)

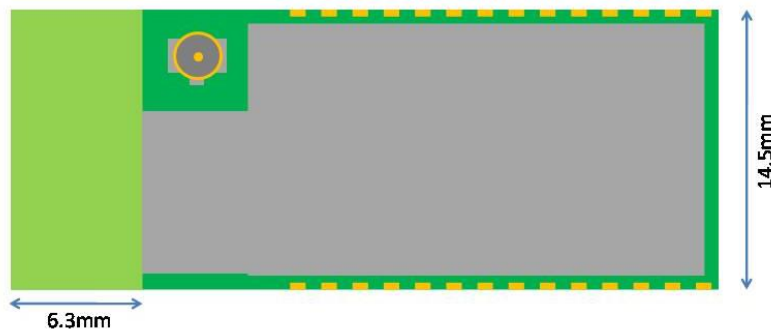
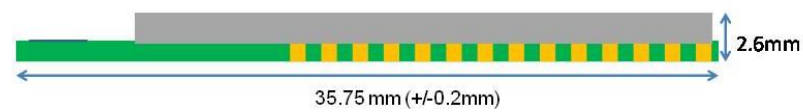

Figure 4: Dimensions of WT11i-E

4.1 Package Dimensions

DEVICE TYPE:WT11i-A

CUSTOMER :

DWG NO :CM0

MATERIAL :P.S0.4黑色

DATE : 99.02.24

ITEM	W	A0	B0	K0	K1	P	E	F	D	D1	P0	P2
DIM	56 ^{+0.3} _{-0.3}	14.8 ^{+0.1} _{-0.1}	36.1 ^{+0.1} _{-0.1}	2.9 ^{+0.1} _{-0.1}	0 ^{+0.1} _{-0.1}	20 ^{+0.1} _{-0.1}	1.75 ^{+0.1} _{-0.1}	26.2 ^{+0.1} _{-0.1}	1.5 ^{+0.1} _{-0.0}	2.0 ^{+0.25} _{-0.0}	4.0 ^{+0.1} _{-0.1}	2.0 ^{+0.1} _{-0.1}

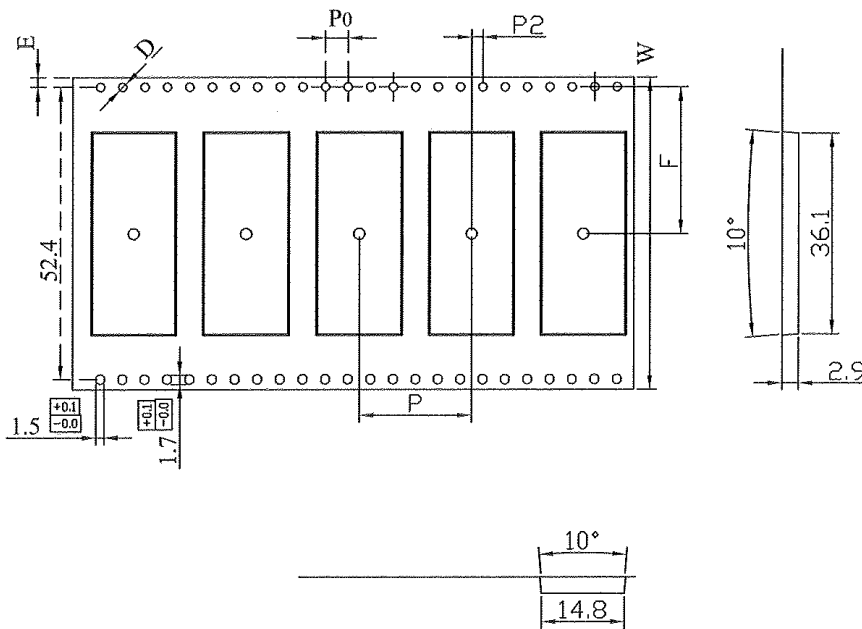

NOTE:

- 1.10 sprocket hole pitch cumulative tolerance±0.2
- 2.Carrier camber is 1mm in 100mm
- 3.A0 and B0 measured on a plane 0.3mm above the bottom of the pocket
- 4.K0 measured from a plane on the inside bottom of the pocket to the top surface of the carrier
- 5.All dimensions meet EIA-481-2 requirements
6. 22" 1R= 65M 3000PCS 13"1R= 500PCS

CUSTOMER: _____

DESIGNER: _____

DRAW: _____

Figure 5: WT11i taping

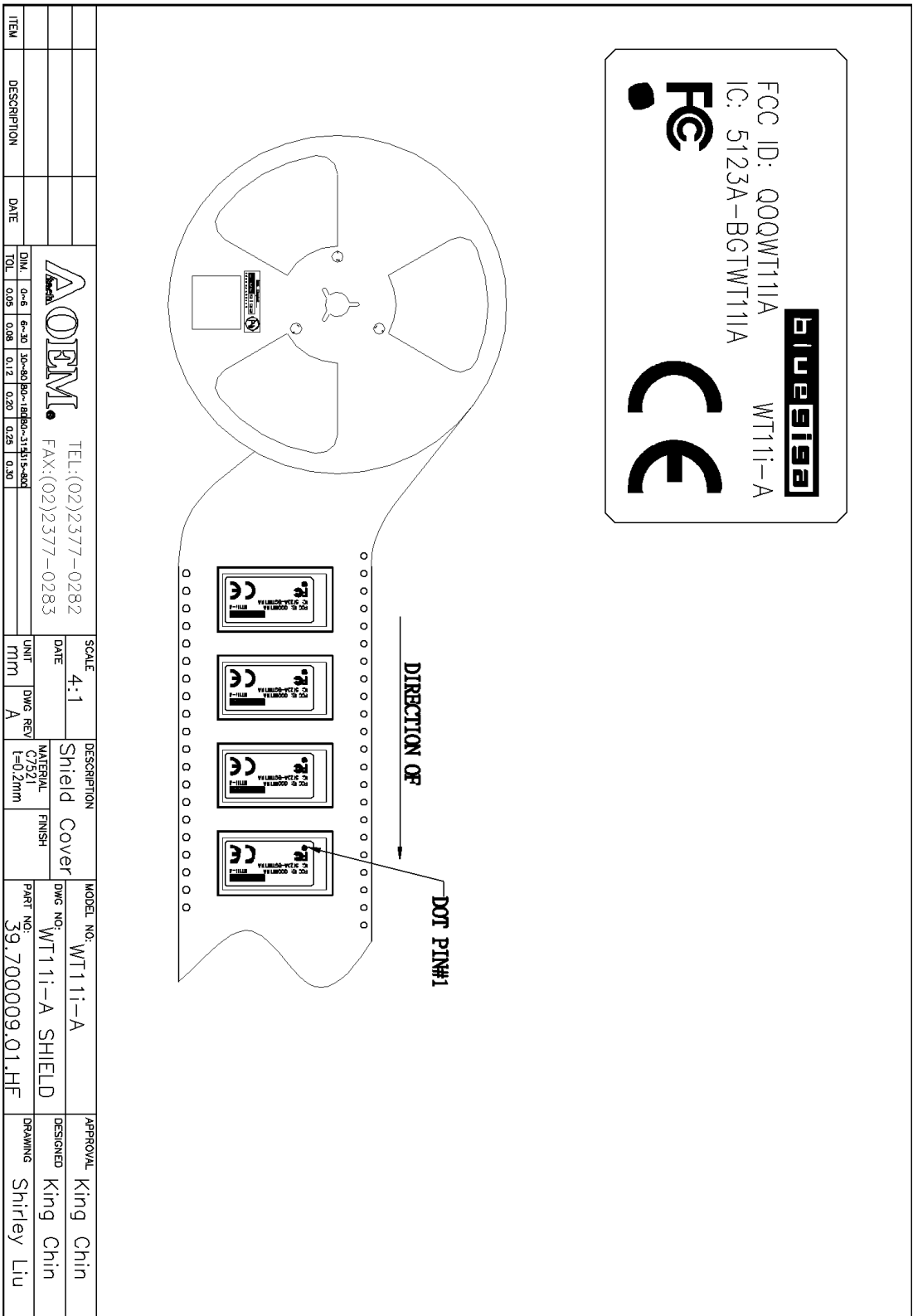

Figure 6: WT11i orientation in the reel

5 Layout Guidelines

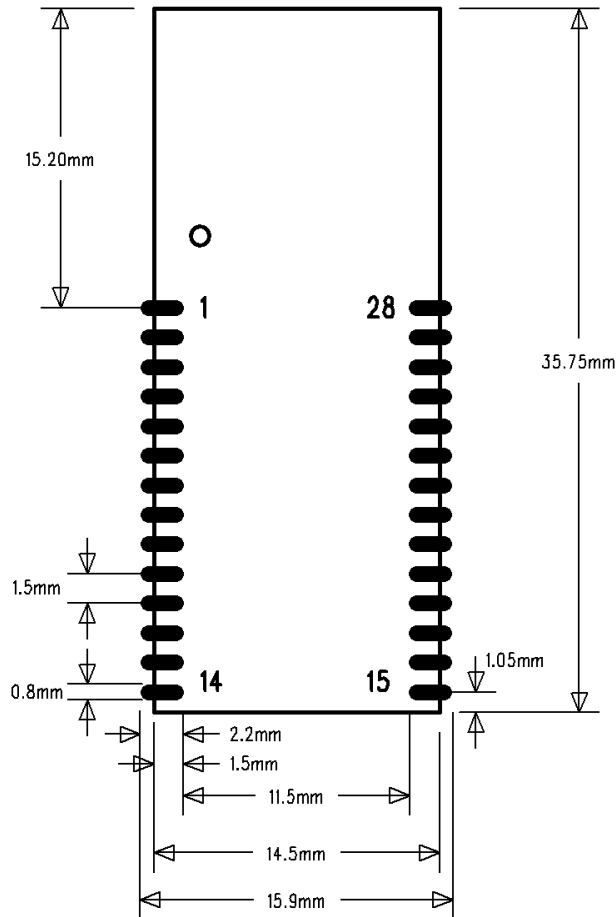

Figure 7: Recommended PCB land pattern

WT11i-E can be placed freely without restrictions anywhere in the mother board. Recommended PCB land pattern is shown in the figure 7. On the contrary to WT11i-A, layout around WT11i-E does not have any impact on the performance of the module as long as following general EMC considerations are taken into account.

Use good layout practices to avoid excessive noise coupling to supply voltage traces or sensitive analog signal traces, such as analog audio signals. If using overlapping ground planes use stitching vias separated by max 3 mm to avoid emission from the edges of the PCB. Connect all the GND pins directly to a solid GND plane and make sure that there is a low impedance path for the return current following the signal and supply traces all the way from start to the end.

A good practice is to dedicate one of the inner layers to a solid GND plane and one of the inner layers to supply voltage planes and traces and route all the signals on top and bottom layers of the PCB. This arrangement will make sure that any return current follows the forward current as close as possible and any loops are minimized.



Figure 8: Typical 4-layer PCB construction

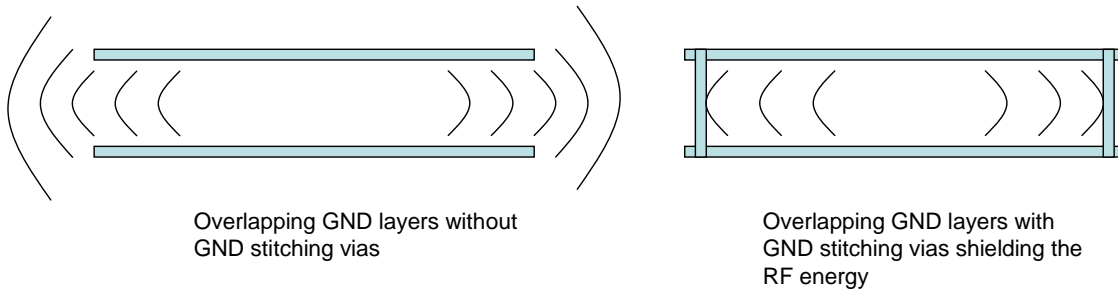

Figure 9: Use of stitching vias to avoid emissions from the edges of the PCB

6 UART Interface

This is a standard UART interface for communicating with other serial devices. WT11i UART interface provides a simple mechanism for communicating with other serial devices using the RS232 protocol.

Four signals are used to implement the UART function. When WT11i is connected to another digital device, UART_RX and UART_TX transfer data between the two devices. The remaining two signals, UART_CTS and UART_RTS, can be used to implement RS232 hardware flow control where both are active low indicators. All UART connections are implemented using CMOS technology and have signalling levels of 0V and VDD.

UART configuration parameters, such as data rate and packet format, are set using WT11i software.

Note:

In order to communicate with the UART at its maximum data rate using a standard PC, an accelerated serial port adapter card is required for the PC.

Parameter	Possible Values	
Data Rate	Minimum	1200 bits/s (2%Error)
		9600 bits/s (1%Error)
	Maximum	3M bit/s (1%Error)
Flow Control	RTS/CTS or None	
Parity	None, Odd or Even	
Number of Stop Bits	1 or 2	
Bits per Channel	8	

Table 11: Possible UART Settings

The UART interface is capable of resetting WT11i upon reception of a break signal. A break is identified by a continuous logic low (0V) on the UART_RX terminal, as shown in Figure 10. If t_{BRK} is longer than the value, defined by PSKEY_HOST_IO_UART_RESET_TIMEOUT, (0x1a4), a reset will occur. This feature allows a host to initialise the system to a known state. Also, WT11i can emit a break character that may be used to wake the host.

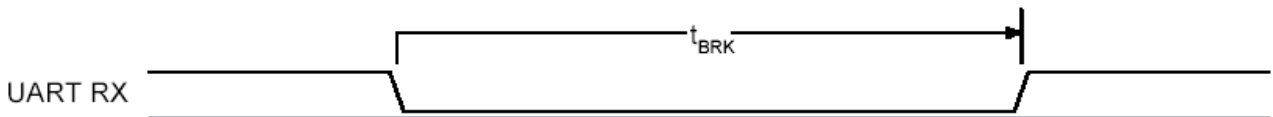

Figure 10: Break Signal

Table 11 shows a list of commonly used data rates and their associated values for PSKEY_UART_BAUD_RATE (0x204). There is no requirement to use these standard values. Any data rate within the supported range can be set in the PS Key according to the formula in Equation 1

$$\text{Data Rate} = \frac{\text{PSKEY_UART_BAUDRATE}}{0.004096}$$

Equation 1: Data Rate

Data Rate (bits/s)	Persistent Store Value	Error	Dec
	Hex		
1200	0x0005	5	1.73%
2400	0x000a	10	1.73%
4800	0x0014	20	1.73%
9600	0x0027	39	-0.82%
19200	0x004f	79	0.45%
38400	0x009d	157	-0.18%
57600	0x00ec	236	0.03%
76800	0x013b	315	0.14%
115200	0x01d8	472	0.03%
230400	0x03b0	944	0.03%
460800	0x075f	1887	-0.02%
921600	0x0ebf	3775	0.00%
1382400	0x161e	5662	-0.01%
1843200	0x1d7e	7550	0.00%
2764800	0x2c3d	11325	0.00%

Table 12: Standard Data Rates

6.1 UART Bypass

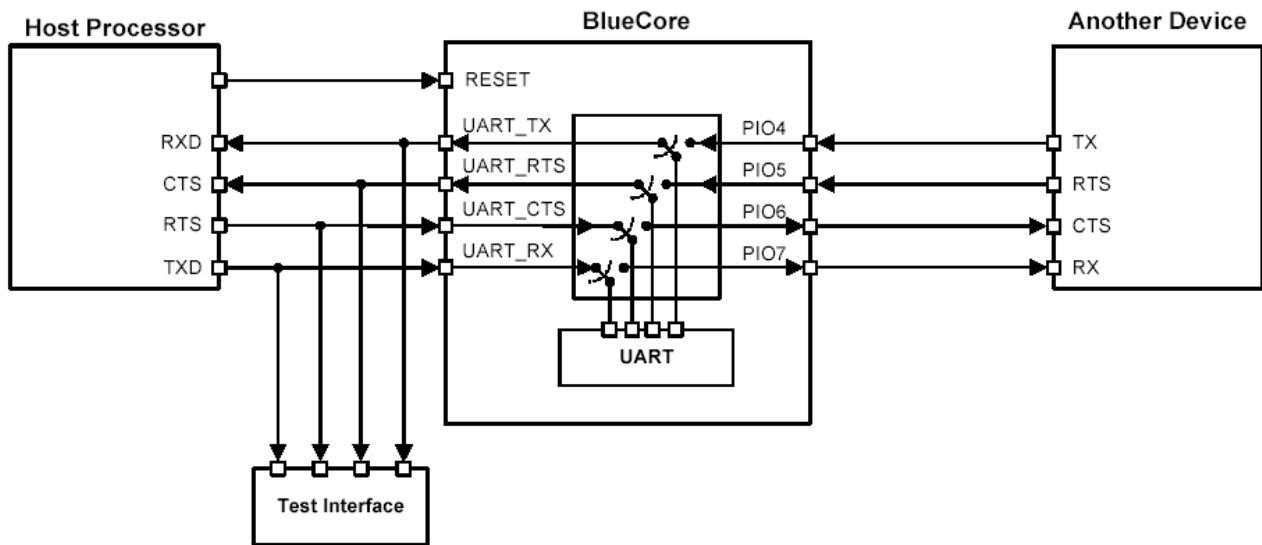

Figure 11: UART Bypass Architecture

6.2 UART Configuration While Reset is Active

The UART interface for WT11i while the chip is being held in reset is tristate. This will allow the user to daisy chain devices onto the physical UART bus. The constraint on this method is that any devices connected to this bus must tristate when WT11i reset is de-asserted and the firmware begins to run.

6.3 UART Bypass Mode

Alternatively, for devices that do not tristate the UART bus, the UART bypass mode on BlueCore4-External can be used. The default state of BlueCore4-External after reset is de-asserted; this is for the host UART bus to be connected to the BlueCore4-External UART, thereby allowing communication to BlueCore4-External via the UART. All UART bypass mode connections are implemented using CMOS technology and have signalling levels of 0V and VDD.

In order to apply the UART bypass mode, a BCCMD command will be issued to BlueCore4-External. Upon this issue, it will switch the bypass to PIO[7:4] as Figure 20 indicates. Once the bypass mode has been invoked, WT11i will enter the Deep Sleep state indefinitely.

In order to re-establish communication with WT11i, the chip must be reset so that the default configuration takes effect.

It is important for the host to ensure a clean Bluetooth disconnection of any active links before the bypass mode is invoked. Therefore, it is not possible to have active Bluetooth links while operating the bypass mode.

The current consumption for a device in UART bypass mode is equal to the values quoted for a device in standby mode.

7 USB Interface

This is a full speed (12Mbits/s) USB interface for communicating with other compatible digital devices. WT11i acts as a USB peripheral, responding to requests from a master host controller such as a PC.

The USB interface is capable of driving a USB cable directly. No external USB transceiver is required. The device operates as a USB peripheral, responding to requests from a master host controller such as a PC. Both the OHCI and the UHCI standards are supported. The set of USB endpoints implemented can behave as specified in the USB section of the Bluetooth v2.1 + EDR specification or alternatively can appear as a set of endpoints appropriate to USB audio devices such as speakers.

As USB is a master/slave oriented system (in common with other USB peripherals), WT11i only supports USB Slave operation.

7.1 USB Data Connections

The USB data lines emerge as pins USB_DP and USB_DN. These terminals are connected to the internal USB I/O buffers of the BlueCore4-External, therefore, have a low output impedance. To match the connection to the characteristic impedance of the USB cable, resistors must be placed in series with USB_DP/USB_DN and the cable.

7.2 USB Pull-Up resistor

WT11i features an internal USB pull-up resistor. This pulls the USB_DP pin weakly high when WT11i is ready to enumerate. It signals to the PC that it is a full speed (12Mbits/s) USB device.

The USB internal pull-up is implemented as a current source, and is compliant with section 7.1.5 of the USB specification v1.2. The internal pull-up pulls USB_DP high to at least 2.8V when loaded with a 15k 5% pull-down resistor (in the hub/host) when VDD_PADS = 3.1V. This presents a Thevenin resistance to the host of at least 900. Alternatively, an external 1.5k pull-up resistor can be placed between a PIO line and D+ on the USB cable. The firmware must be alerted to which mode is used by setting PSKEY_USB_PIO_PULLUP appropriately. The default setting uses the internal pull-up resistor.

7.3 USB Power Supply

The USB specification dictates that the minimum output high voltage for USB data lines is 2.8V. To safely meet the USB specification, the voltage on the VDD supply terminal must be an absolute minimum of 3.1V. Bluegiga recommends 3.3V for optimal USB signal quality.

7.4 Self-Powered Mode

In self-powered mode, the circuit is powered from its own power supply and not from the VBUS (5V) line of the USB cable. It draws only a small leakage current (below 0.5mA) from VBUS on the USB cable. This is the easier mode for which to design, as the design is not limited by the power that can be drawn from the USB hub or root port. However, it requires that VBUS be connected to WT11i via a resistor network (Rvb1 and Rvb2), so WT11i can detect when VBUS is powered up. BlueCore4-External will not pull USB_DP high when VBUS is off.

Self-powered USB designs (powered from a battery or PSU) must ensure that a PIO line is allocated for USB pullup purposes. A 1.5k 5% pull-up resistor between USB_DP and the selected PIO line should be fitted to the design. Failure to fit this resistor may result in the design failing to be USB compliant in self-powered mode. The internal pull-up in BlueCore is only suitable for bus-powered USB devices, e.g., dongles.

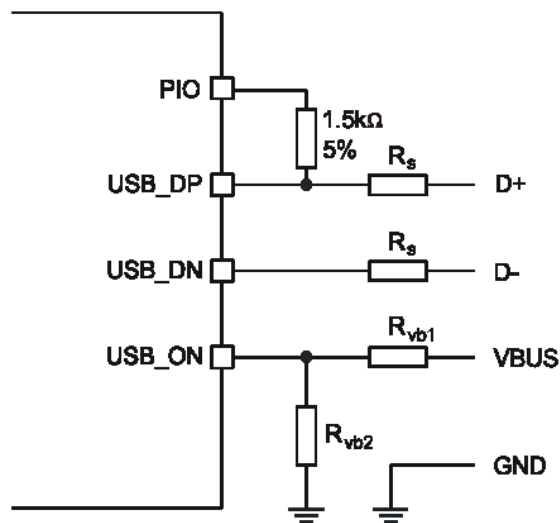

Figure 12: USB Connections for Self-Powered Mode

The terminal marked USB_ON can be any free PIO pin. The PIO pin selected must be registered by setting PSKEY_USB_PIO_VBUS to the corresponding pin number.

Identifier	Value	Function
R_s	0 to 10 (to be matched per design)**	Impedance matching to USB cable
R_{vb1}	22k 5%	VBUS ON sense divider
R_{vb2}	47k 5%	VBUS ON sense divider

Figure 13: USB Interface Component Values

**) WT11i has internal 22 ohm series resistors at the USB lines.

7.5 Bus-Powered Mode

In bus-powered mode, the application circuit draws its current from the 5V VBUS supply on the USB cable. WT11i negotiates with the PC during the USB enumeration stage about how much current it is allowed to consume. On power-up the device must not draw more than 100 mA but after being configured it can draw up to 500 mA.

For WT11i, the USB power descriptor should be altered to reflect the amount of power required. This is accomplished by setting PSKEY_USB_MAX_POWER (0x2c6). This is higher than for a Class 2 application due to the extra current drawn by the Transmit RF PA. By default for WT11i the setting is 300 mA.

When selecting a regulator, be aware that VBUS may go as low as 4.4V. The inrush current (when charging reservoir and supply decoupling capacitors) is limited by the USB specification. See the USB Specification. Some applications may require soft start circuitry to limit inrush current if more than 10uF is present between VBUS and GND. The 5V VBUS line emerging from a PC is often electrically noisy. As well as regulation down to 3.3V and 1.8V, applications should include careful filtering of the 5V line to attenuate noise that is above the voltage regulator bandwidth. Excessive noise on WT11i supply pins will result in reduced receiver sensitivity and a distorted RF transmit signal.

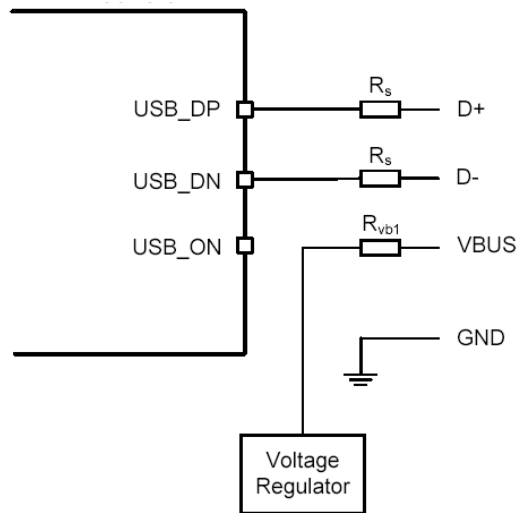

Figure 14: USB Connections for Bus-Powered Mode

7.6 USB Suspend Current

All USB devices must permit the USB controller to place them in a USB suspend mode. While in USB Suspend, bus-powered devices must not draw more than 2.5mA from USB VBUS (self-powered devices may draw more than 2.5mA from their own supply). This current draw requirement prevents operation of the radio by bus-powered devices during USB Suspend.

When computing suspend current, the current from VBUS through the bus pull-up and pull-down resistors must be included. The pull-up resistor at the device is 1.5 k. (nominal). The pull-down resistor at the hub is 14.25k. to 24.80k. The pull-up voltage is nominally 3.3V, which means that holding one of the signal lines high takes approximately 200uA, leaving only 2.3mA available from a 2.5mA budget. Ensure that external LEDs and/or amplifiers can be turned off by BlueCore4-External. The entire circuit must be able to enter the suspend mode.

7.7 USB Detach and Wake-Up Signaling

WT11i can provide out-of-band signaling to a host controller by using the control lines called USB_DETACH and USB_WAKE_UP. These are outside the USB specification (no wires exist for them inside the USB cable), but can be useful when embedding WT11i into a circuit where no external USB is visible to the user. Both control lines are shared with PIO pins and can be assigned to any PIO pin by setting PSKEY_USB_PIO_DETACH and PSKEY_USB_PIO_WAKEUP to the selected PIO number.

USB_DETACH is an input which, when asserted high, causes WT11i to put USB_DN and USB_DP in high impedance state and turns off the pull-up resistor on DP. This detaches the device from the bus and is logically equivalent to unplugging the device. When USB_DETACH is taken low, WT11i will connect back to USB and await enumeration by the USB host.

USB_WAKE_UP is an active high output (used only when USB_DETACH is active) to wake up the host and allow USB communication to recommence. It replaces the function of the software USB_WAKE_UP message (which runs over the USB cable) and cannot be sent while BlueCore4-External is effectively disconnected from the bus.

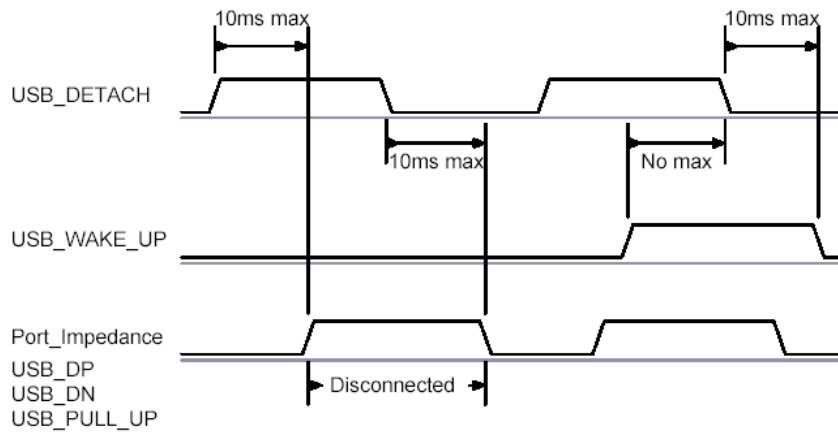

Figure 15: USB_Detach and USB_Wake_Up Signals

7.8 USB Driver

A USB Bluetooth device driver is required to provide a software interface between BlueCore4-External and Bluetooth software running on the host computer. Please, contact support@bluegiga.com for suitable drivers.

7.9 USB v2.0 Compliance and Compatibility

Although WT11i meets the USB specification, CSR cannot guarantee that an application circuit designed around the module is USB compliant. The choice of application circuit, component choice and PCB layout all affect USB signal quality and electrical characteristics. The information in this document is intended as a guide and should be read in association with the USB specification, with particular attention being given to Chapter 7. Independent USB qualification must be sought before an application is deemed USB compliant and can bear the USB logo. Such qualification can be obtained from a USB plugfest or from an independent USB test house.

Terminals USB_DP and USB_DN adhere to the USB Specification v2.0 (Chapter 7) electrical requirements.

BlueCore4-External is compatible with USB v2.0 host controllers; under these circumstances the two ends agree the mutually acceptable rate of 12Mbits/s according to the USB v2.0 specification.

8 Serial Peripheral Interface (SPI)

The SPI port can be used for system debugging. It can also be used for programming the Flash memory and setting the PSKEY configurations. WT11i uses 16-bit data and 16-bit address serial peripheral interface, where transactions may occur when the internal processor is running or is stopped. SPI interface is connected using the MOSI, MISO, CSB and CLK pins.

SPI interface cannot be used for application purposes.

9 PCM Codec Interface

PCM is a standard method used to digitize audio (particularly voice) for transmission over digital communication channels. Through its PCM interface, WT11i has hardware support for continual transmission and reception of PCM data, thus reducing processor overhead for wireless headset applications. WT11i offers a bidirectional digital audio interface that routes directly into the baseband layer of the on-chip firmware. It does not pass through the HCI protocol layer.

Hardware on WT11i allows the data to be sent to and received from a SCO connection. Up to three SCO connections can be supported by the PCM interface at any one time.

WT11i can operate as the PCM interface master generating an output clock of 128, 256 or 512kHz. When configured as PCM interface slave, it can operate with an input clock up to 2048kHz. WT11i is compatible with a variety of clock formats, including Long Frame Sync, Short Frame Sync and GCI timing environments.

It supports 13-bit or 16-bit linear, 8-bit μ -law or A-law companded sample formats at 8ksamples/s and can receive and transmit on any selection of three of the first four slots following PCM_SYNC. The PCM configuration options are enabled by setting PSKEY_PCM_CONFIG32.

WT11i interfaces directly to PCM audio devices.

NOTE: Analog audio lines are very sensitive to RF disturbance. Use good layout practices to ensure noise less audio. Make sure that the return path for the audio signals follows the forward current all the way as close as possible and use fully differential signals when possible. Do not compromise audio routing.

9.1 PCM Interface Master/Slave

When configured as the master of the PCM interface, WT11i generates PCM_CLK and PCM_SYNC.

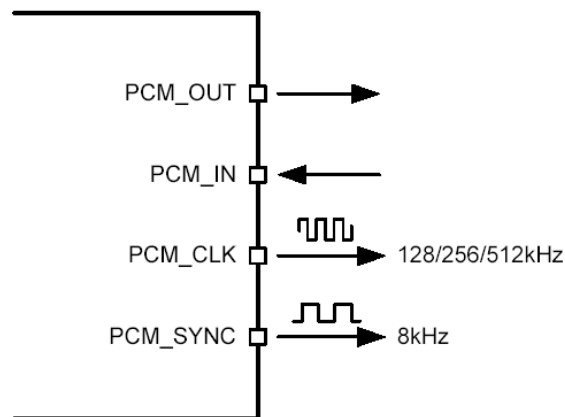

Figure 16: PCM Interface Master

When configured as the Slave of the PCM interface, WT11i accepts PCM_CLK rates up to 2048kHz.

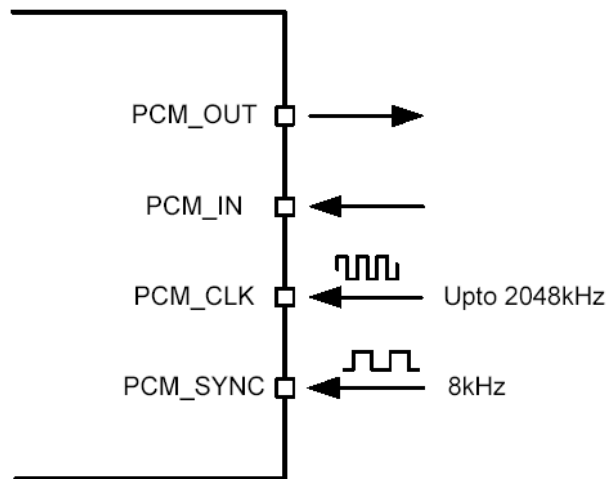

Figure 17: PCM Interface Slave

9.2 Long Frame Sync

Long Frame Sync is the name given to a clocking format that controls the transfer of PCM data words or samples. In Long Frame Sync, the rising edge of PCM_SYNC indicates the start of the PCM word. When WT11i is configured as PCM master, generating PCM_SYNC and PCM_CLK, then PCM_SYNC is 8-bits long. When WT11i is configured as PCM Slave, PCM_SYNC may be from two consecutive falling edges of PCM_CLK to half the PCM_SYNC rate, i.e., 62.5s long.

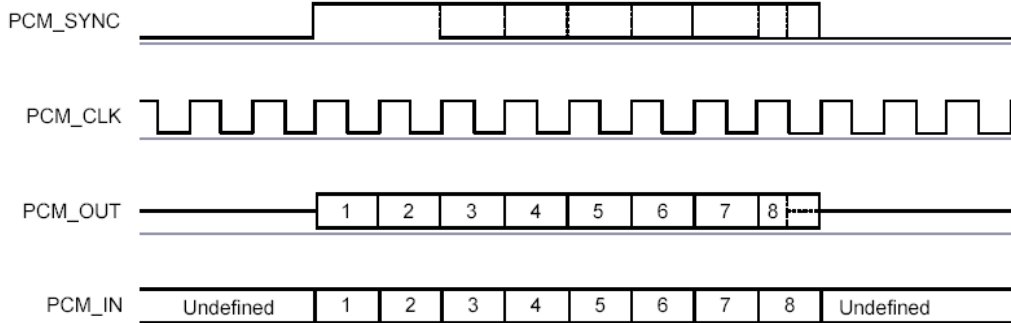

Figure 18: Long Frame Sync (Shown with 8-bit Companded Sample)

WT11i samples PCM_IN on the falling edge of PCM_CLK and transmits PCM_OUT on the rising edge. PCM_OUT may be configured to be high impedance on the falling edge of PCM_CLK in the LSB position or on the rising edge.

9.3 Short Frame Sync

In Short Frame Sync, the falling edge of PCM_SYNC indicates the start of the PCM word. PCM_SYNC is always one clock cycle long.

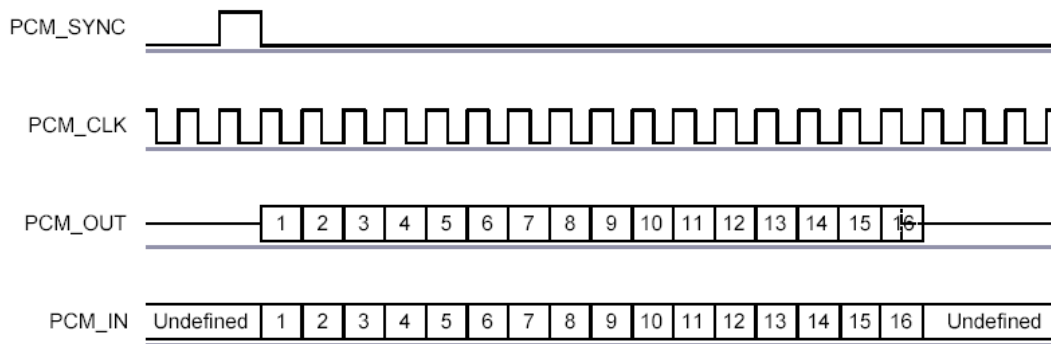

Figure 19: Short Frame Sync (Shown with 16-bit Sample)

As with Long Frame Sync, WT11i samples PCM_IN on the falling edge of PCM_CLK and transmits PCM_OUT on the rising edge. PCM_OUT may be configured to be high impedance on the falling edge of PCM_CLK in the LSB position or on the rising edge.

9.4 Multi-slot Operation

More than one SCO connection over the PCM interface is supported using multiple slots. Up to three SCO connections can be carried over any of the first four slots.

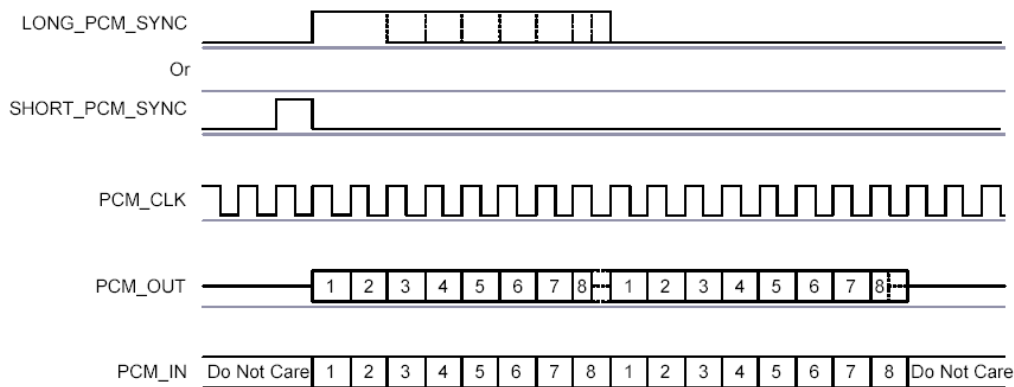

Figure 20: Multi-slot Operation with Two Slots and 8-bit Companded Samples

9.5 GCI Interface

WT11i is compatible with the GCI, a standard synchronous 2B+D ISDN timing interface. The two 64kbits/s B channels can be accessed when this mode is configured.

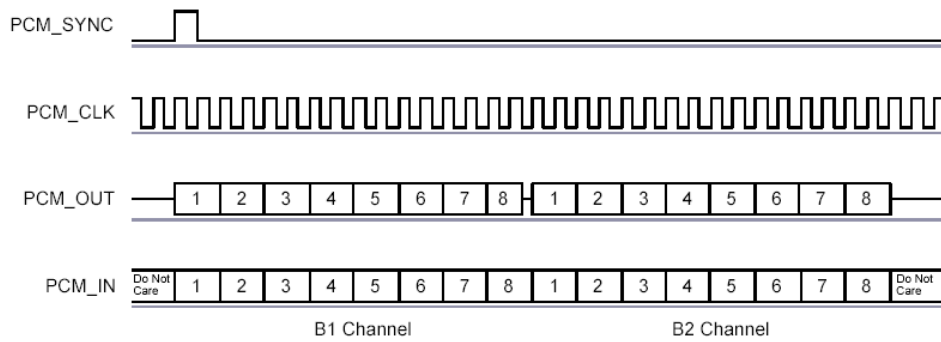

Figure 21: GCI Interface

The start of frame is indicated by the rising edge of PCM_SYNC and runs at 8kHz. With WT11i in Slave mode, the frequency of PCM_CLK can be up to 4.096MHz.

9.6 Slots and Sample Formats

WT11i can receive and transmit on any selection of the first four slots following each sync pulse. Slot durations can be either 8 or 16 clock cycles. Durations of 8 clock cycles may only be used with 8-bit sample formats. Durations of 16 clocks may be used with 8-bit, 13-bit or 16-bit sample formats.

WT11i supports 13-bit linear, 16-bit linear and 8-bit -law or A-law sample formats. The sample rate is 8ksamples/s. The bit order may be little or big endian. When 16-bit slots are used, the 3 or 8 unused bits in each slot may be filled with sign extension, padded with zeros or a programmable 3-bit audio attenuation compatible with some Motorola codecs.

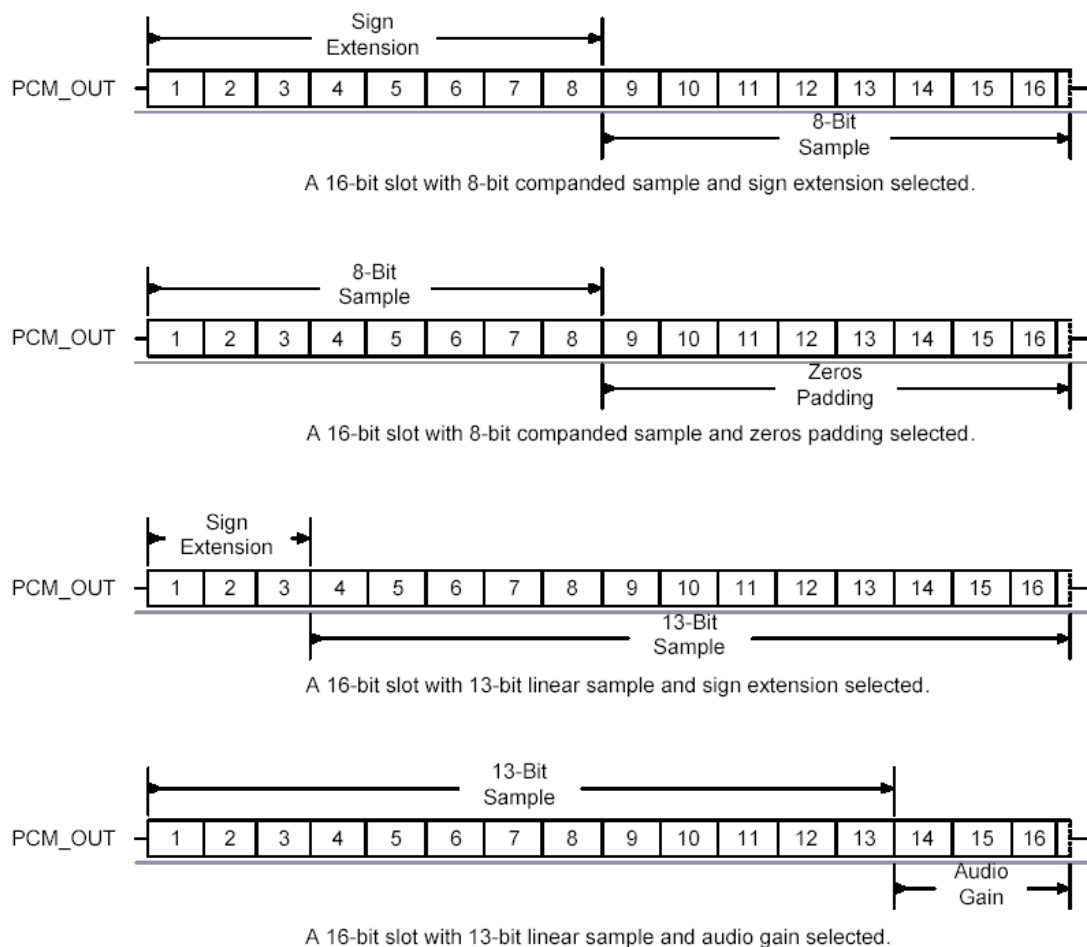

Figure 22: 16-bit Slot Length and Sample Formats

9.7 Additional Features

WT11i has a mute facility that forces PCM_OUT to be 0. In master mode, PCM_SYNC may also be forced to 0 while keeping PCM_CLK running which some codecs use to control power down.

9.8 PCM_CLK and PCM_SYNC Generation

WT11i has two methods of generating PCM_CLK and PCM_SYNC in master mode. The first is generating these signals by DDS from BlueCore4-External internal 4MHz clock. Using this mode limits PCM_CLK to 128, 256 or 512kHz and PCM_SYNC to 8kHz. The second is generating PCM_CLK and PCM_SYNC by DDS from an internal 48MHz clock (which allows a greater range of frequencies to be generated with low jitter but consumes more power). This second method is selected by setting bit 48M_PCM_CLK_GEN_EN in PSKEY_PCM_CONFIG32. When in this mode and with long frame sync, the length of PCM_SYNC can be either 8 or 16 cycles of PCM_CLK, determined by LONG_LENGTH_SYNC_EN in PSKEY_PCM_CONFIG32.

The Equation XXX describes PCM_CLK frequency when being generated using the internal 48MHz clock:

$$f = \frac{\text{CNT_RATE}}{\text{CNT_LIMIT}} \times 24\text{MHz}$$

Equation 2: PCM_CLK Frequency When Being Generated Using the Internal 48MHz Clock

The frequency of PCM_SYNC relative to PCM_CLK can be set using Equation XXX:

$$f = \frac{\text{PCM_CLK}}{\text{SYNC_LIMIT} \times 8}$$

Equation 3: PCM_SYNC Frequency Relative to PCM_CLK

CNT_RATE, CNT_LIMIT and SYNC_LIMIT are set using PSKEY_PCM_LOW_JITTER_CONFIG. As an example, to generate PCM_CLK at 512kHz with PCM_SYNC at 8kHz, set PSKEY_PCM_LOW_JITTER_CONFIG to 0x08080177.

9.9 PCM Configuration

The PCM configuration is set using two PS Keys, PSKEY_PCM_CONFIG32 detailed in Table 12 and PSKEY_PCM_LOW_JITTER_CONFIG in Table 13. The default for PSKEY_PCM_CONFIG32 is 0x00800000, i.e., first slot following sync is active, 13-bit linear voice format, long frame sync and interface master generating 256kHz PCM_CLK from 4MHz internal clock with no tri-state of PCM_OUT.

Name	Bit position	Description
-	0	Set to 0
SLAVE MODE EN	1	0 selects Master mode with internal generation of PCM_CLK and PCM_SYNC. 1 selects Slave mode requiring externally generated PCM_CLK and PCM_SYNC. This should be set to 1 if 48M_PCM_CLK_GEN_EN (bit 11) is set.
SHORT SYNC EN	2	0 selects long frame sync (rising edge indicates start of frame), 1 selects short frame sync (falling edge indicates start of frame).
-	3	Set to 0
SIGN EXTENDED EN	4	0 selects padding of 8 or 13-bit voice sample into a 16-bit slot by inserting extra LSBs, 1 selects sign extension. When padding is selected with 3-bit voice sample, the 3 padding bits are the audio gain setting; with 8-bit samples the 8 padding bits are zeroes.
LSB FIRST EN	5	0 transmits and receives voice samples MSB first, 1 uses LSB first.
TX TRISTATE EN	6	0 drives PCM_OUT continuously, 1 tri-states PCM_OUT immediately after the falling edge of PCM_CLK in the last bit of an active slot, assuming the next slot is not active.
TX TRISTATE RISING EDGE EN	7	0 tristates PCM_OUT immediately after the falling edge of PCM_CLK in the last bit of an active slot, assuming the next slot is also not active. 1 tristates PCM_OUT after the rising edge of PCM_CLK.
SYNC SUPPRESS EN	8	0 enables PCM_SYNC output when master, 1 suppresses PCM_SYNC whilst keeping PCM_CLK running. Some CODECS utilize this to enter a low power state.
GCI MODE EN	9	1 enables GCI mode.
MUTE EN	10	1 forces PCM_OUT to 0.
48M PCM CLK GEN EN	11	0 sets PCM_CLK and PCM_SYNC generation via DDS from internal 4 MHz clock, as for BlueCore4-External. 1 sets PCM_CLK and PCM_SYNC generation via DDS from internal 48 MHz clock.
LONG LENGTH SYNC EN	12	0 sets PCM_SYNC length to 8 PCM_CLK cycles and 1 sets length to 16 PCM_CLK cycles. Only applies for long frame sync and with 48M_PCM_CLK_GEN_EN set to 1.
-	[20:16]	Set to 0b00000.
MASTER CLK RATE	[22:21]	Selects 128 (0b01), 256 (0b00), 512 (0b10) kHz PCM_CLK frequency when master and 48M_PCM_CLK_GEN_EN (bit 11) is low.
ACTIVE SLOT	[26:23]	Default is 0001. Ignored by firmware
SAMPLE_FORMAT	[28:27]	Selects between 13 (0b00), 16 (0b01), 8 (0b10) bit sample with 16 cycle slot duration 8 (0b11) bit sample 8 cycle slot duration.

Table 13: PSKEY_PCM_CONFIG32 description

Name	Bit position	Description
CNT LIMIT	[12:0]	Sets PCM_CLK counter limit
CNT RATE	[23:16]	Sets PCM_CLK count rate.
SYNC LIMIT	[31:24]	Sets PCM_SYNC division relative to PCM_CLK.

Table 14: PSKEY_PCM_LOW_JITTER_CONFIG Description

10 I/O Parallel Ports

Six lines of programmable bidirectional input/outputs (I/O) are provided. All the PIO lines are power from VDD.

PIO lines can be configured through software to have either weak or strong pull-ups or pull-downs. All PIO lines are configured as inputs with weak pull-downs at reset. Any of the PIO lines can be configured as interrupt request lines or as wake-up lines from sleep modes.

WT11i has a general purpose analogue interface pin AIO[1]. This is used to access internal circuitry and control signals. It may be configured to provide additional functionality.

Auxiliary functions available via AIO[1] include an 8-bit ADC and an 8-bit DAC. Typically the ADC is used for battery voltage measurement. Signals selectable at this pin include the band gap reference voltage and a variety of clock signals: 48, 24, 16, 8MHz and the XTAL clock frequency. When used with analogue signals, the voltage range is constrained by the analogue supply voltage internally to the module (1.8V). When configured to drive out digital level signals (e.g., clocks), the output voltage level is determined by VDD.

10.1 PIO Defaults

Bluegiga cannot guarantee that these terminal functions remain the same. Refer to the software release note for the implementation of these PIO lines, as they are firmware build-specific.

11 Reset

WT11i may be reset from several sources: RESET pin, power on reset, a UART break character or via software configured watchdog timer. The RESET pin is an active high reset and is internally filtered using the internal low frequency clock oscillator. A reset will be performed between 1.5 and 4.0ms following RESETB being active. It is recommended that RESET be applied for a period greater than 5ms.

The power on reset occurs when the VDD_CORE supply internally to the module falls below typically 1.5V and is released when VDD_CORE rises above typically 1.6V. At reset the digital I/O pins are set to inputs for bidirectional pins and outputs are tri-state.

WT11i has an internal power on reset circuit which holds the module in reset until all the supply voltages have stabilized. The reset pin must be either floating or connected to high impedance during power on in order for the power on reset circuit to work properly. If the reset pin is not connected to high impedance during power on, then one must ensure that the reset is kept active until all the supply voltages have stabilized to prevent the flash memory getting corrupted.

11.1 Pin States on Reset

PIN NAME	STATE
PIO[7:2]	Input with weak pull-down
PCM_OUT	Tri-staed with weak pull-down
PCM_IN	Input with weak pull-down
PCM_SYNC	Input with weak pull-down
PCM_CLK	Input with weak pull-down
UART_TX	Output tristated with weak pull-up
UART_RX	Input with weak pull-down
UART_RTS	Output tristated with weak pull-up
UART_CTS	Input with weak pull-down
USB+	Input with weak pull-down
USB-	Input with weak pull-down
SPI_CSB	Input with weak pull-down
SPI_CLK	Input with weak pull-down
SPI_MOSI	Input with weak pull-down
SPI_MISO	Output tristated with weak pull-down
AIO[1]	Output, driving low

Table 15: Pin States on Reset

12 Certifications

WT11i-E is compliant to the following specifications. At the time of writing this version the official approval for these specifications is still in the process. Immediately when Bluegiga has received the approval this disclaimer is removed and the new version of this document is published.

12.1 Bluetooth

WT11i-E module is *Bluetooth* qualified and listed as a controller subsystem and it is Bluetooth compliant to the following profiles of the core spec version 2.1/2.1+EDR.

- Baseband
- HCI
- Link Manager
- Radio

12.2 FCC and IC

For FCC, if the TX power of a Bluetooth module is higher than 13.9 dBm and the end product is used closer than 20 cm from a human body, RF exposure has to be evaluated in the end product. For IC there is a similar requirement except the power limit is 12 dBm. This might require either an own FCC ID for the end product, or Class 2 Permissive Change to the grant of WT11i. WT11i is certified with both 12 dBm (FCC ID: QQQWT11IA) and 17 dBm (FCC ID: QQQWT11I) TX power. When using QQQWT11IA, RF exposure evaluation is not needed, but the TX power must be limited to 12 dBm.

WT11i complies with Part 15 of the FCC Rules. Operation is subject to the following two conditions:

- (1) this device may not cause harmful interference, and
- (2) this device must accept any interference received, including interference that may cause undesired operation.

FCC RF Radiation Exposure Statement:

This equipment complies with FCC radiation exposure limits set forth for an uncontrolled environment. End users must follow the specific operating instructions for satisfying RF exposure compliance. This transmitter must not be co-located or operating in conjunction with any other antenna or transmitter, except in accordance with FCC test procedures. This transmitter is considered as mobile device. If TX power is set to 17 dBm, class 2 permissive change is required to allow portable use in a known host. Please contact support@bluegiga.com for detailed information.

IC Statements:

This device complies with Industry Canada licence-exempt RSS standard(s). Operation is subject to the following two conditions: (1) this device may not cause interference, and (2) this device must accept any interference, including interference that may cause undesired operation of the device.

Under Industry Canada regulations, this radio transmitter may only operate using an antenna of a type and maximum (or lesser) gain approved for the transmitter by Industry Canada. To reduce potential radio interference to other users, the antenna type and its gain should be so chosen that the equivalent isotropically radiated power (e.i.r.p.) is not more than that necessary for successful communication.

OEM Responsibilities to comply with FCC and Industry Canada Regulations

The WT11i-E module has been certified for integration into products only by OEM integrators under the following conditions:

- The antenna(s) must be installed such that a minimum separation distance of 20cm is maintained between the radiator (antenna) and all persons at all times.
- The transmitter module must not be co-located or operating in conjunction with any other antenna or transmitter.

As long as the two conditions above are met, further transmitter testing will not be required. However, the OEM integrator is still responsible for testing their end-product for any additional compliance requirements required with this module installed (for example, digital device emissions, PC peripheral requirements, etc.).

IMPORTANT NOTE: In the event that these conditions cannot be met (for certain configurations or co-location with another transmitter), then the FCC and Industry Canada authorizations are no longer considered valid and the FCC ID and IC Certification Number cannot be used on the final product. In these circumstances, the OEM integrator will be responsible for re-evaluating the end product (including the transmitter) and either obtaining a separate FCC and Industry Canada authorization or ask for Bluegiga to make a Class 2 Permissive Change to the listing of the module. With a Class 2 Permissive Change the OEM integrator can still use the FCC ID and IC Certification Number of the module in the final product and the responsibility of compliance remains at Bluegiga.

End Product Labeling

The WT11i-E Module is labeled with its own FCC ID and IC Certification Number. If the FCC ID and IC Certification Number are not visible when the module is installed inside another device, then the outside of the device into which the module is installed must also display a label referring to the enclosed module. In that case, the final end product must be labeled in a visible area with the following:

“Contains Transmitter Module FCC ID: QQQWT11I”

“Contains Transmitter Module IC: 5123A-BGTWT11I”

or

“Contains FCC ID: QQQWT11I

“Contains IC: 5123A-BGTWT11I”

The OEM of the WT11i-E module must only use the approved antenna.

The OEM integrator has to be aware not to provide information to the end user regarding how to install or remove this RF module or change RF related parameters in the user manual of the end product.

To comply with FCC and Industry Canada RF radiation exposure limits for general population, the antenna(s) used for this transmitter must be installed such that a minimum separation distance of 20cm is maintained between the radiator (antenna) and all persons at all times and must not be co-located or operating in conjunction with any other antenna or transmitter.

12.2.1 FCC et IC

Cet appareil est conforme à l'alinéa 15 des règles de la FCC. Deux conditions sont à respecter lors de son utilisation :

- (1) cet appareil ne doit pas créer d'interférence susceptible de causer un quelconque dommage et,
- (2) cet appareil doit accepter toute interférence, quelle qu'elle soit, y compris les interférences susceptibles d'entraîner un fonctionnement non requis.

Déclaration de conformité FCC d'exposition aux radiofréquences (RF):

Ce matériel respecte les limites d'exposition aux radiofréquences fixées par la FCC dans un environnement non contrôlé. Les utilisateurs finaux doivent se conformer aux instructions d'utilisation spécifiées afin de satisfaire aux normes d'exposition en matière de radiofréquence. Ce transmetteur ne doit pas être installé ni utilisé en concomitance avec une autre antenne ou un autre transmetteur. Ce transmetteur est assimilé à un appareil mobile et ne doit pas être utilisé à moins de 20 cm du corps humain. Afin de permettre un usage mobile dans le cadre d'un matériel de catégorie 2, il est nécessaire de procéder à quelques adaptations. Pour des informations détaillées, veuillez contacter le support technique Bluegiga : support@bluegiga.com.

Déclaration de conformité IC :

Ce matériel respecte les standards RSS exempt de licence d'Industrie Canada. Son utilisation est soumise aux deux conditions suivantes :

- (1) l'appareil ne doit causer aucune interférence, et
- (2) l'appareil doit accepter toute interférence, quelle qu'elle soit, y compris les interférences susceptibles d'entraîner un fonctionnement non requis de l'appareil.

Selon la réglementation d'Industrie Canada, ce radio-transmetteur ne peut utiliser qu'un seul type d'antenne et ne doit pas dépasser la limite de gain autorisée par Industrie Canada pour les transmetteurs. Afin de réduire les interférences potentielles avec d'autres utilisateurs, le type d'antenne et son gain devront être définis de telle façon que la puissance isotrope rayonnante équivalente (EIRP) soit juste suffisante pour permettre une bonne communication.

Les responsabilités de l'intégrateur afin de satisfaire aux réglementations de la FCC et d'Industrie Canada :

Les modules WT11i ont été certifiés pour entrer dans la fabrication de produits exclusivement réalisés par des intégrateurs dans les conditions suivantes :

- L'antenne (ou les antennes) doit être installée de façon à maintenir à tout instant une distance minimum de 20cm entre la source de radiation (l'antenne) et toute personne physique.
- Le module transmetteur ne doit pas être installé ou utilisé en concomitance avec une autre antenne ou un autre transmetteur.

Tant que ces deux conditions sont réunies, il n'est pas nécessaire de procéder à des tests supplémentaires sur le transmetteur. Cependant, l'intégrateur est responsable des tests effectués sur le produit final afin de se mettre en conformité avec d'éventuelles exigences complémentaires lorsque le module est installé (exemple : émissions provenant d'appareils numériques, exigences vis-à-vis de périphériques informatiques, etc.) ;

IMPORTANT : Dans le cas où ces conditions ne peuvent être satisfaites (pour certaines configurations ou installation avec un autre transmetteur), les autorisations fournies par la FCC et Industrie Canada ne sont plus valables et les numéros d'identification de la FCC et de certification d'Industrie Canada ne peuvent servir pour le produit final. Dans ces circonstances, il incombera à l'intégrateur de faire réévaluer le produit final (comprenant le transmetteur) et d'obtenir une autorisation séparée de la part de la FCC et d'Industrie Canada.

Etiquetage du produit final

Chaque module WT11i possède sa propre identification FCC et son propre numéro de certification IC. Si l'identification FCC et le numéro de certification IC ne sont pas visibles lorsqu'un module est installé à l'intérieur d'un autre appareil, alors l'appareil en question devra lui aussi présenter une étiquette faisant référence au module inclus. Dans ce cas, le produit final doit comporter une étiquette placée de façon visible affichant les mentions suivantes :

« **Contient un module transmetteur certifié FCC QOQWT11I** »

« **Contient un module transmetteur certifié IC 5123A-BGTWT11I** »

ou

« **Inclut la certification FCC QOQWT11I** »

« **Inclut la certification IC 5123A-BGTWT11I** »

L'intégrateur du module WT11i ne doit utiliser que les antennes répertoriées dans le tableau 21 certifiées pour ce module.

L'intégrateur est tenu de ne fournir aucune information à l'utilisateur final autorisant ce dernier à installer ou retirer le module RF, ou bien changer les paramètres RF du module, dans le manuel d'utilisation du produit final.

Afin de se conformer aux limites de radiation imposées par la FCC et Industry Canada, l'antenne (ou les antennes) utilisée pour ce transmetteur doit être installée de telle sorte à maintenir une distance minimum de 20cm à tout instant entre la source de radiation (l'antenne) et les personnes physiques. En outre, cette antenne ne devra en aucun cas être installée ou utilisée en concomitance avec une autre antenne ou un autre transmetteur.

12.3CE

WT11i meets the requirements of the standards below and hence fulfills the requirements of EMC Directive 89/336/EEC as amended by Directives 92/31/EEC and 93/68/EEC within CE marking requirement.

- EMC (immunity only) EN 301 489-17 V.1.3.3 in accordance with EN 301 489-1 V1.8.1
- Radiated emissions EN 300 328 V1.7.1
- Safety EN60950-1:2006+A11:2009+A1:2010+A12:2011

12.4 MIC Japan

WT11i has type approval in Japan with identification code R 209- J00053

12.5 Qualified Antenna Types for WT11i-E

This device has been designed to operate with a standard 2.14 dBi dipole antenna. Any antenna of a different type or with a gain higher than 2.14 dBi is strictly prohibited for use with this device. Using an antenna of a different type or gain more than 2.14 dBi will require additional certifications. Please, contact support@bluegiga.com for more information. The required antenna impedance is 50 ohms.

Qualified Antenna Types for WT11i-E	
Antenna Type	Maximum Gain
Dipole	2.14 dBi

Table 16: Qualified Antenna Types for WT11i-E

To reduce potential radio interference to other users, the antenna type and its gain should be so chosen that the equivalent isotropically radiated power (e.i.r.p.) is not more than that permitted for successful communication.

Any standard 2.14 dBi dipole antenna can be used without an additional application to FCC. Table 16 lists approved antennas for WT11i-E. Any approved antenna listed in table 16 can be used directly with WT11i-E without any additional approval. Any antenna not listed in table 16 can be used with WT11i-E as long as detailed information from that particular antenna is provided to Bluegiga for approval. Specification of each antenna used with WT11i-E will be filed by Bluegiga as a Class 1 Permissive Change. Please, contact support@bluegiga.com for more information.

Item	Manufacturer	Manufacturers part number	Measured Gain (dBi)	Specified Gain (dBi)	Measure Total Efficiency (%)
1	Pulse	W1030	1	2 dBi	70 - 80
2	Linx Technologies Inc	ANT-2.4-CW-CT-SMA	1.3	2 dBi	77
3	EAD	EA-79A	0.4	2 dBi	60
4	Antenova	B4844/B6090	1.4	2 dBi	76 - 82
5	Litecon	CAR-ATR-187-001	0.8	2 dBi	60 - 70

Table 17: Approved Antennas for WT11i-E

13 Contact Information

Sales: sales@bluegiga.com

Technical support: <http://techforum.bluegiga.com>

Orders: orders@bluegiga.com

WWW: www.bluegiga.com
www.bluegiga.hk

Head Office / Finland:

Phone: +358-9-4355 060
Fax: +358-9-4355 0660
Sinikalliontie 5A
02630 ESPOO
FINLAND

Postal address / Finland:

P.O. BOX 120
02631 ESPOO
FINLAND

Sales Office / USA:



Phone: +1 770 291 2181
Fax: +1 770 291 2183
Bluegiga Technologies, Inc.
3235 Satellite Boulevard, Building 400, Suite 300
Duluth, GA, 30096, USA

Sales Office / Hong-Kong:







Phone: +852 3182 7321
Fax: +852 3972 5777
Bluegiga Technologies, Inc.
19/F Silver Fortune Plaza, 1 Wellington Street,
Central Hong Kong

Looking for pricing, stock, or lifecycle information?

Click below to explore more details on WIN SOURCE:

-  [View WT11I-E-AI5 on WIN SOURCE](#)
-  [Silicon Labs Information](#)

Optimize Your Supply Chain with WIN SOURCE Solutions

-  Global Sourcing Solution
-  Obsolete Management
-  Cost Control Management
-  Shortage Management
-  Alternative Solution
-  Excess Inventory Management