



**THE DATASHEET OF
WF04H1000DTL**



APPROVAL SHEET

WF10H, WF12H, WF08H, WF06H, WF04H

$\pm 0.5\%$, $\pm 0.1\%$

Thick Film High Precision Chip Resistors

Size 1210, 1206, 0805, 0603, 0402

RoHS 2 Compliant with exemption 7C-I

Halogen free



*Contents in this sheet are subject to change without prior notice.

FEATURE

1. Small size and light weight
2. High reliability and stability
3. Reduced size of final equipment
4. High precision
5. Higher component and equipment reliability
6. RoHS 2 Compliant with exemption 7C-I and Halogen free products

APPLICATION

- Power supply
- PDA
- Digital meter
- Computer
- Palmtop computers

DESCRIPTION

The resistors are constructed in a high grade ceramic body (aluminum oxide). Internal metal electrodes are added at each end and connected by a resistive paste that is applied to the top surface of the substrate. The composition of the paste is adjusted to give the approximate resistance required and the value is trimmed to nominated value within tolerance which controlled by laser trimming of this resistive layer.

The resistive layer is covered with a protective coat. Finally, the two external end terminations are added. For ease of soldering the outer layer of these end terminations is a Tin (lead free) alloy.

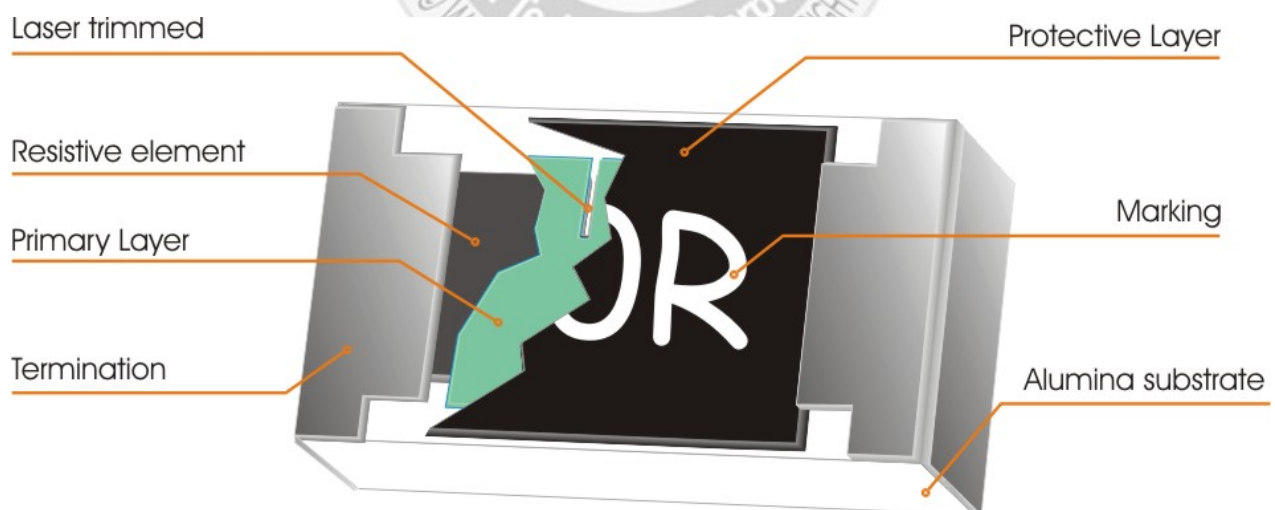

Fig 1. Construction of Chip-R

QUICK REFERENCE DATA

Item	General Specification				
	WF10H	WF12H	WF08H	WF06H	WF04H
Series No.	WF10H	WF12H	WF08H	WF06H	WF04H
Size code	1210 (3226)	1206 (3216)	0805 (2125)	0603 (1608)	0402 (1005)
Resistance Range	10Ω ~ 1MΩ (E96+E24 series)				
Resistance Tolerance	±0.5%, ±0.1%				
TCR (ppm/°C) 10Ω ≤ R ≤ 1MΩ	≤ ± 100 ppm/°C				
Max. dissipation at T _{amb} =70°C	1/3 W	1/4 W	1/8 W	1/10 W	1/16W
Max. Operation Voltage (DC or RMS)	200V	200V	150V	75V	50V
Max. overload voltage (DC or RMS)	400V	400V	300V	150V	100V
Climatic category	55/155/56				

Note :

1. This is the maximum voltage that may be continuously supplied to the resistor element, see "IEC publication 60115-8"
2. Max. Operation Voltage : So called RCWV (Rated Continuous Working Voltage) is determined by

$$RCWV = \sqrt{\text{Rated Power} \times \text{Resistance Value}} \text{ or Max. RCWV listed above, whichever is lower.}$$

DIMENSIONS(unit : mm)

Series No.	WF10H	WF12H	WF08H	WF06H	WF04H
L	3.10 ± 0.10	3.10 ± 0.1	2.0 ± 0.10	1.60 ± 0.10	1.00±0.05
W	2.60 ± 0.10	1.60 ± 0.1	1.25 ± 0.10	0.80 ± 0.10	0.50±0.05
Tt	0.50 ± 0.20	0.50 ± 0.2	0.40 ± 0.20	0.30 ± 0.10	0.20±0.10
Tb	0.50 ± 0.20	0.45 ± 0.2	0.40 ± 0.20	0.30 ± 0.20	0.25±0.10
T	0.55 ± 0.10	0.65 ± 0.15	0.5 ± 0.15	0.45 ± 0.15	0.35±0.05

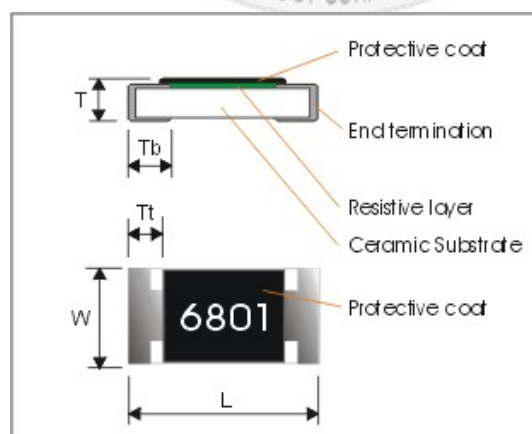

CATALOGUE NUMBERS

The resistors have a catalogue number starting with :

WF06	H	3742	D	T	L
Size code	Type code	Resistance code	Tolerance	Packaging code	Termination code
WF10: 1210 WF12 : 1206 WF08 : 0805 WF06 : 0603 WF04 : 0402	H : High precision, <1%	E96+E24: 3 significant digits followed by no. of zeros 102Ω =1020 37.4KΩ =3742 220Ω =2200	D : ±0.5% B : ±0.1%	T : 7" Reeled taping	L = Sn base (lead free)

- Reeled tape packaging: 8mm width paper taping 5,000pcs per 7" reel for 1210/1206/0805/0603, 10,000pcs per 7" reel for 0402.

MARKING

- 3 digits marking for 0603 size:**

WFxxH has same marking rule as WR ±1%

Nominal resistance	Description
1.E-24 series	As 0603 WR06X ±5%.
2.E-96 series	The 1st two digit codes are referring to the CODE on the table, the 3rd code is the index of resistance value : Y=10 ⁻² , X=10 ⁻¹ , A=10 ⁰ , B=10 ¹ , C=10 ² , D=10 ³ , E=10 ⁴ , F=10 ⁵ EX : 17.8Ω=25X, 178Ω=25A, 1K78 =25B 17K8=25C, 178K=25D, 1M78=25E
3. Remark	There is no marking for the items are not under E-24 and E-96 series

CODE	R_value	CODE	R_value	CODE	R_value	CODE	R_value	CODE	R_value	CODE	R_value	CODE	R_value	CODE	R_value
01	100	13	133	25	178	37	237	49	316	61	422	73	562	85	750
02	102	14	137	26	182	38	243	50	324	62	432	74	576	86	768
03	105	15	140	27	187	39	249	51	332	63	442	75	590	87	787
04	107	16	143	28	191	40	255	52	340	64	453	76	604	88	806
05	110	17	147	29	196	41	261	53	348	65	464	77	619	89	825
06	113	18	150	30	200	42	267	54	357	66	475	78	634	90	845
07	115	19	154	31	205	43	274	55	365	67	487	79	649	91	866
08	118	20	158	32	210	44	280	56	374	68	499	80	665	92	887
09	121	21	162	33	215	45	287	57	383	69	511	81	681	93	909
10	124	22	165	34	221	46	294	58	392	70	523	82	698	94	931
11	127	23	169	35	226	47	301	59	402	71	536	83	715	95	953
12	130	24	174	36	232	48	309	60	412	72	549	84	732	96	976

- 4 digits marking for 1210, 1206, 0805 size:**

Each resistor is marked with a four digits code on the protective coating to designate the nominal resistance value. For values below 97Ω6 the R is used as a digit. For values of 100Ω or greater, the first 3 digits are significant, and the fourth digit indicates the number of multiple to follow.

Example

RESISTANCE	10Ω	12Ω	100Ω	6800Ω	47000Ω
4 digits marking	10R0	12R0	1000	6801	4702

- No marking code for 0402 size.**

FUNCTIONAL DESCRIPTION

Product characterization

Standard values of nominal resistance are taken from the E96 & E24 series for resistors with a tolerance of $\pm 0.5\%$, $\pm 0.1\%$. The values of the E24/E96 series are in accordance with "IEC publication 60063".

Derating

The power that the resistor can dissipate depends on the operating temperature; see Fig.2

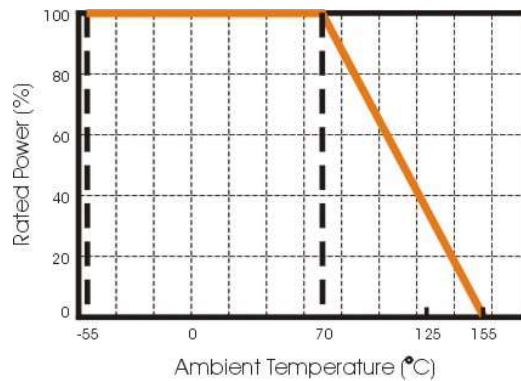

Figure 2. Maximum dissipation in percentage of rated power
As a function of the ambient temperature

MOUNTING

Due to their rectangular shapes and small tolerances, Surface Mountable Resistors are suitable for handling by automatic placement systems.

Chip placement can be on ceramic substrates and printed-circuit boards (PCBs).

Electrical connection to the circuit is by individual soldering condition.

Storage and Handling Conditions:

1. Products are recommended to be used up within two years since operation date as ensured shelf life. Check solderability in case shelf life extension is needed.
2. To store products with following condition:
 - Temperature :5 to 40°C
 - Humidity :20 to 70% relative humidity
3. Caution:
 - a. Don't store products in a corrosive environment such as sulfide, chloride gas, or acid.
It may cause oxidation of electrode, which easily be resulted in poor soldering.
 - b. To store products on the shelf and avoid exposure to moisture.
 - c. Don't expose products to excessive shock, vibration, direct sunlight and so on.

SOLDERING CONDITION follows J-STD-020D

The robust construction of chip resistors allows them to be completely immersed in a solder bath of 260°C for 10 seconds. Therefore, it is possible to mount Surface Mount Resistors on one side of a PCB and other discrete components on the reverse (mixed PCBs).

Surface Mount Resistors are tested for solderability at 235°C during 2 seconds. The test condition for no leaching is 260°C for 30 seconds.

Typical examples of soldering processes that provide reliable joints without any damage are given in Fig 3

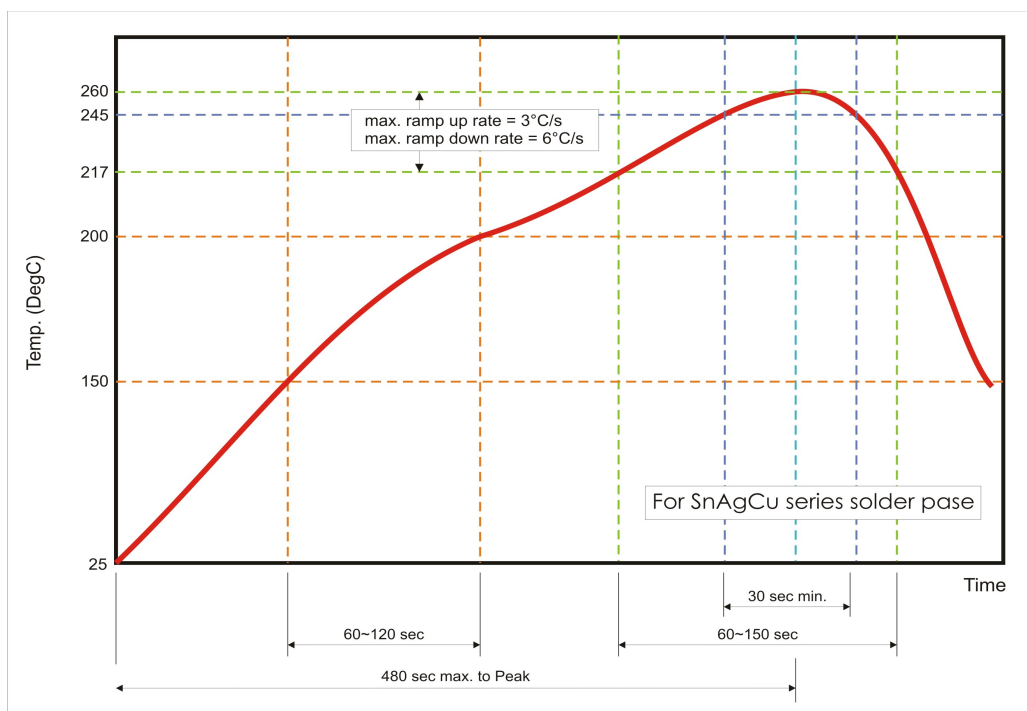

Fig 3. Recommended IR reflow soldering profile for SMT process with SnAgCu series solder paste

TEST AND REQUIREMENTS (JIS C 5201-1 : 1998)

Essentially all tests are carried out according to the schedule of IEC publication 115-8, category LCT/UCT/56 (rated temperature range : Lower Category Temperature, Upper Category Temperature; damp heat, long term, 56 days). The testing also meets the requirements specified by EIA, EIAJ and JIS.

The tests are carried out in accordance with IEC publication 68, "Recommended basic climatic and mechanical robustness testing procedure for electronic components" and under standard atmospheric conditions according to IEC 60068-1, subclause 5.3. Unless otherwise specified, the following value supplied :

Temperature: 15°C to 35°C.

Relative humidity: 45% to 75%.

Air pressure: 86kPa to 106 kPa (860 mbar to 1060 mbar).

All soldering tests are performed with mildly activated flux.

TEST	PROCEDURE	REQUIREMENT
DC resistance Clause 4.5	DC resistance values measured at the test voltages specified below : <10Ω@0.1V, <100Ω@0.3V, <1KΩ@1.0V, <10KΩ@3V, <100KΩ@10V, <1MΩ@25V, <10MΩ@30V	Within the specified tolerance
Temperature Coefficient of Resistance(T.C.R) Clause 4.8	Natural resistance change per change in degree centigrade. $\frac{R_2 - R_1}{R_1(t_2 - t_1)} \times 10^6$ (ppm/°C) ; t1 : 20°C+5°C-1°C R1 : Resistance at reference temperature R2 : Resistance at test temperature	Refer to "QUICK REFERENCE DATA"
Short time overload (S.T.O.L) Clause 4.13	Permanent resistance change after a 5second application of a voltage 2.5 times RCWV or the maximum overload voltage specified in the above list, whichever is less.	ΔR/R max. ±(0.25%+0.05Ω)
Resistance to soldering heat(R.S.H) Clause 4.18	Un-mounted chips completely immersed for 10±1second in a SAC solder bath at 260 C ±5°C	no visible damage Δ R/R max. ±(0.25%+0.05Ω)
Solderability Clause 4.17	Un-mounted chips completely immersed for 2±0.5 second in a SAC solder bath at 235°C±5°C	good tinning (>95% covered) no visible damage
Temperature cycling Clause 4.19	30 minutes at -55°C±3°C, 2~3 minutes at 20°C+5°C-1°C, 30 minutes at +155°C±3°C, 2~3 minutes at 20°C+5°C-1°C, total 5 continuous cycles	no visible damage ΔR/R max. ±(0.25%+0.05Ω)
Load life (endurance) Clause 4.25	1000 +48/-0 hours, loaded with RCWV or Vmax in chamber controller 70±2°C, 1.5 hours on and 0.5 hours off	ΔR/R max. ±(1%+0.1Ω)
Load life in Humidity Clause 4.24	1000 +48/-0 hours, loaded with RCWV or Vmax in humidity chamber controller at 40°C±2°C and 90~95% relative humidity, 1.5hours on and 0.5 hours off	ΔR/R max. ±(1%+0.1Ω)
Bending strength Clause 4.33	Resistors mounted on a 90mm glass epoxy resin PCB(FR4); bending : 3 mm, once for 10 seconds	ΔR/R max. ±(0.25%+0.05Ω)
Adhesion Clause 4.32	Pressurizing force: 5N, Test time: 10±1sec.	No remarkable damage or removal of the terminations.
Insulation Resistance Clause 4.6	Apply the maximum overload voltage (DC) for 1minute	R ≥ 10G Ω
Dielectric Withstand Voltage Clause 4.7	Apply the maximum overload voltage (AC) for 1 minute	No breakdown or flashover

PACKAGING

Paper Tape specifications (unit :mm)

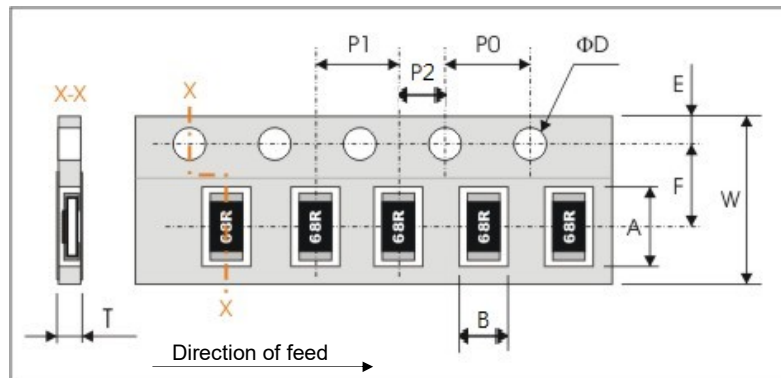

Series No.	A	B	W	F	E
WF10H	3.60±0.20	3.00±0.20	8.00±0.30	3.50±0.20	1.75±0.10
WF12H	3.60±0.20	2.00±0.20	8.00±0.30	3.50±0.2	1.75±0.10
WF08H	2.40±0.20	1.65±0.20	8.00±0.30	3.50±0.2	1.75±0.10
WF06H	1.90±0.20	1.10±0.20	8.00±0.30	3.50±0.2	1.75±0.10
WF04H	1.20±0.10	0.7±0.10	8.00±0.30	3.50±0.05	1.75±0.10

Series No.	P1	P0	P2	ΦD	T
WF10H	4.00±0.10	4.00±0.10	2.00±0.10	Φ1.50 ^{+0.1} _{-0.0}	Max. 1.0
WF12H	4.00±0.10	4.00±0.10	2.00±0.10		0.65±0.1
WF08H	4.00±0.10	4.00±0.10	2.00±0.10		0.65±0.1
WF06H	4.00±0.10	4.00±0.10	2.00±0.10		0.65±0.1
WF04H	2.00±0.10	4.00±0.10	2.00±0.10		0.40±0.05

Reel dimensions

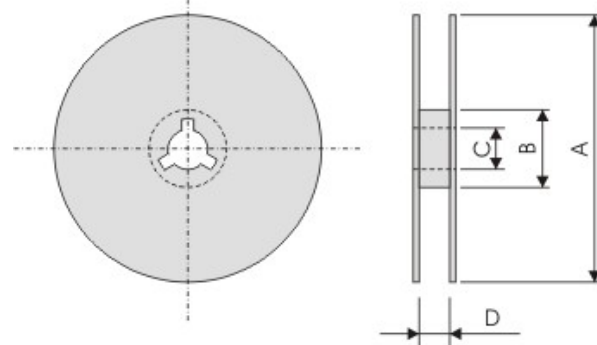

Symbol	A	B	C	D
(unit : mm)	Φ178.0±2.0	Φ60.0±1.0	13.0±0.2	9.0±0.5

Taping quantity

- Chip resistors 5,000 pcs/reel for WF10H, WF12H, WF08H, WF06H.
- Chip resistors 10,000 pcs/reel for WF04H.

Looking for pricing, stock, or lifecycle information?

Click below to explore more details on WIN SOURCE:

- ⊖ [View WF04H1000DTL on WIN SOURCE](#)
- ⊖ [Walsin Technology Corporation Information](#)

Optimize Your Supply Chain with WIN SOURCE Solutions

- ✓ Global Sourcing Solution
- ✓ Obsolete Management
- ✓ Cost Control Management
- ✓ Shortage Management
- ✓ Alternative Solution
- ✓ Excess Inventory Management