



THE DATASHEET OF BOOSTXL-EDUMKII



BOOSTXL-EDUMKII Educational BoosterPack™ Plug-in Module Mark II



ABSTRACT

The **BOOSTXL-EDUMKII** BoosterPack™ (see [Figure 1-1](#)) kit is an easy-to-use plug-in module that offers a high level of integration for developers to quickly add to LaunchPad™ development kit designs. Various analog and digital inputs and outputs are at your disposal including an analog joystick, environmental and motion sensors, RGB LED, microphone, buzzer, color LCD display, and more.

This BoosterPack plug-in module was developed with Energia in mind. Energia is an open-source community-developed coding environment, which is supported by a robust framework of intuitive APIs and easy-to-use software libraries for rapid firmware development. TI recommends Energia v12 or later. Learn more about Energia at www.energia.nu.

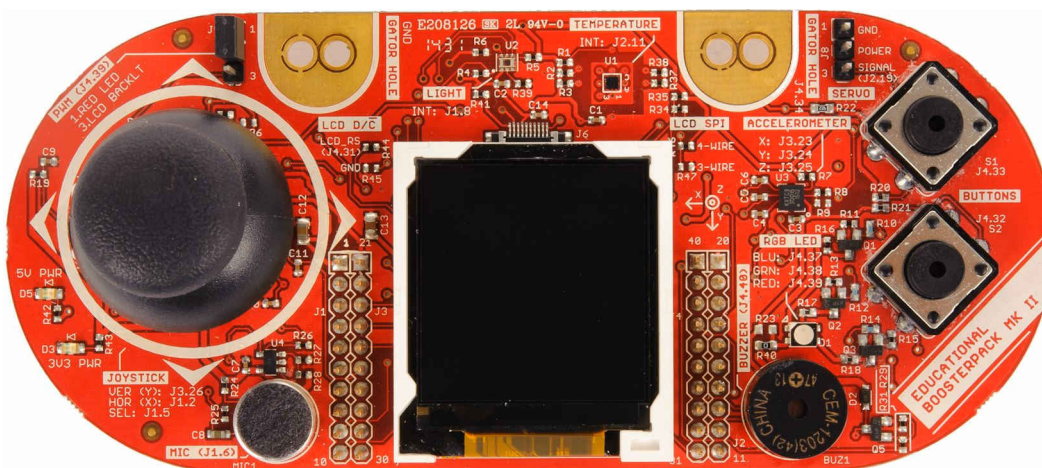

Figure 1-1. BOOSTXL-EDUMKII BoosterPack Plug-in Module

Trademarks

BoosterPack™, LaunchPad™, SimpleLink™, MSP432™, Code Composer Studio™, and E2E™ are trademarks of Texas Instruments.

IAR Embedded Workbench® is a registered trademark of IAR Systems.

Keil® and µVision® are registered trademarks of ARM Limited.

Wi-Fi® is a registered trademark of Wi-Fi Alliance.

Bluetooth® is a registered trademark of Bluetooth SIG.

All trademarks are the property of their respective owners.

Table of Contents

1 Getting Started	3
1.1 Introduction.....	3
1.2 Key Features.....	3
1.3 What's Included.....	3
1.4 Next Steps: Looking Into the Provided Code.....	3
2 Hardware	4
2.1 Hardware Features.....	5
2.2 Power.....	8
2.3 Design Files.....	9
2.4 Hardware Change log.....	9
3 Software Examples	10
3.1 BOOSTXL-EDUMKII_Accelerometer_MSP432P401R.....	10
3.2 BOOSTXL-EDUMKII_JoyStick_MSP432P401R.....	12
3.3 BOOSTXL-EDUMKII_LightSensor_MSP432P401R.....	13
3.4 BOOSTXL-EDUMKII_Temperature_MSP432P401R.....	14
3.5 BOOSTXL-EDUMKII_MicrophoneFFT_MSP432P401R.....	15
4 Additional Resources	17
4.1 TI LaunchPad Development Kit Portal.....	17
4.2 Download Code Composer Studio IDE, IAR, or Energia.....	17
4.3 SimpleLink MSP432 SDK and TI Resource Explorer.....	17
4.4 The Community.....	17
5 Schematics	18
6 Revision History	19

1 Getting Started

1.1 Introduction

The BOOSTXL-EDUMKII BoosterPack plug-in module is an easy-to-use plug-in module that offers a high level of integration for developers to quickly add to LaunchPad development kit designs. Various analog and digital inputs and outputs are at your disposal including an analog joystick, environmental and motion sensors, RGB LED, microphone, buzzer, color LCD display, and more.

This BoosterPack plug-in module was developed with Energia in mind. Energia is an open source, community developed coding environment, which is supported by a robust framework of intuitive APIs and easy-to-use software libraries for rapid firmware development. TI recommends Energia v12 or later. Learn more about Energia at www.energia.nu.

1.2 Key Features

- TI OPT3001 light sensor
- TI TMP006 temperature sensor
- Servo motor connector
- 3-axis accelerometer
- RGB multicolor LED
- Piezo buzzer
- Color 128x128 TFT LCD display
- Microphone
- 2-axis joystick with pushbutton
- User push buttons
- 40-pin BoosterPack plug-in module standard for use with any LaunchPad development kit

1.3 What's Included

1.3.1 Kit Contents

- 1 x BOOSTXL-EDUMKII BoosterPack plug-in module
- 1 x Quick Start Guide

1.3.2 Software Examples

- SimpleLink™ [MSP-EXP432P401R LaunchPad development kit](#) + BOOSTXL-EDUMKII demos (see [Section 3](#))
 - BOOSTXL-EDUMKII_Accelerometer_MSP432P401R
 - BOOSTXL-EDUMKII_JoyStick_MSP432P401R
 - BOOSTXL-EDUMKII_LightSensor_MSP432P401R
 - BOOSTXL-EDUMKII_Temperature_MSP432P401R
 - BOOSTXL-EDUMKII_MicrophoneFFT_MSP432P401R

1.4 Next Steps: Looking Into the Provided Code

After the EVM features have been explored, the fun can begin. It's time to open an integrated development environment (IDE) and start looking at the code examples. [Section 3](#) describes the example projects available to make it easy to understand the provided software. For more information on where to find and download an IDE, see [Section 4](#).

2 Hardware

Figure 2-1 is an overview of the BOOSTXL-EDUMKII hardware.

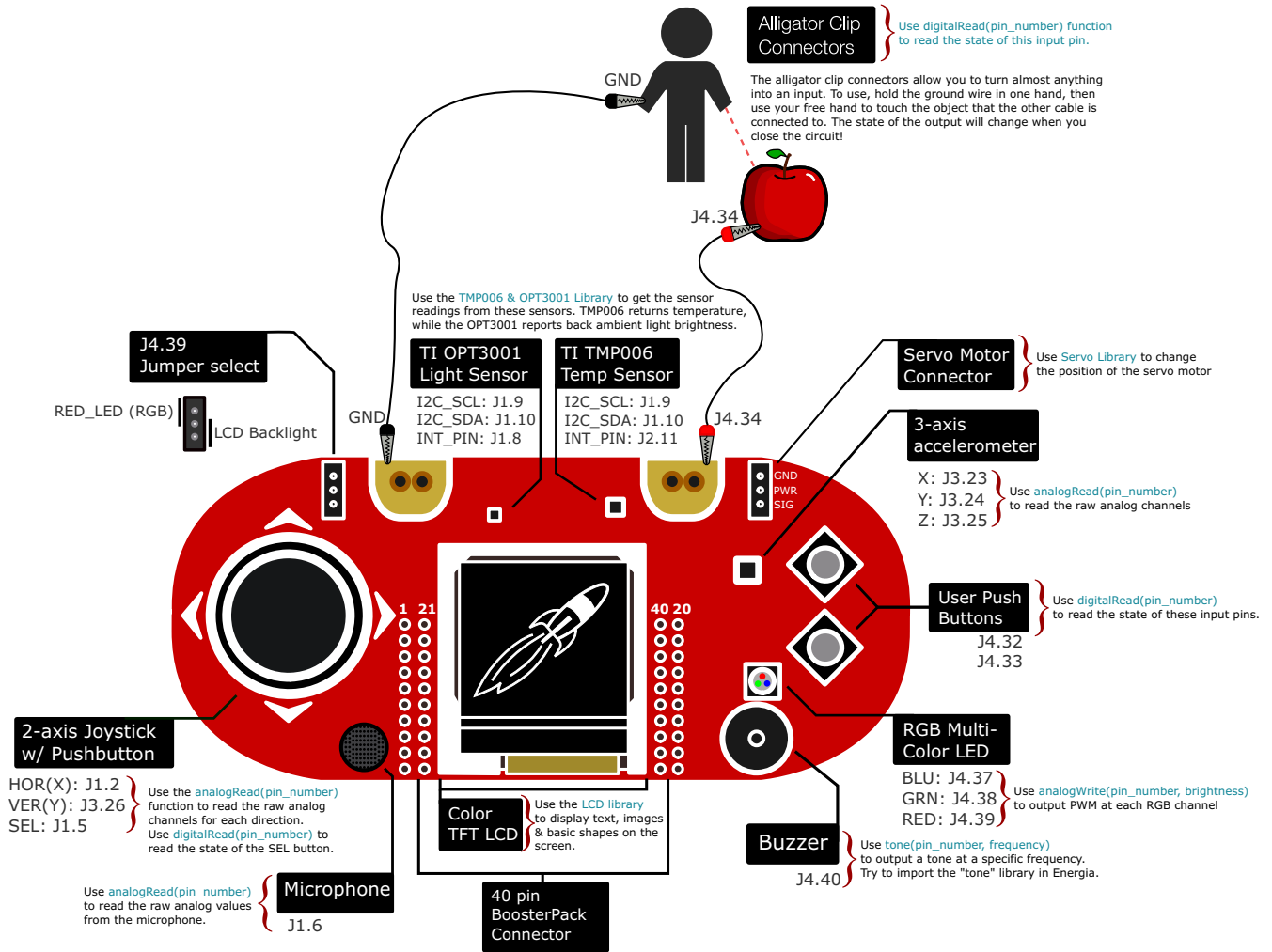

Figure 2-1. BOOSTXL-EDUMKII Overview

2.1 Hardware Features

2.1.1 BoosterPack Plug-in Module Pinout

The Educational BoosterPack plug-in module MKII adheres to the 40-pin LaunchPad development kit and BoosterPack plug-in module pinout standard (see Figure 2-2). A standard was created to aid compatibility between LaunchPad development kits and BoosterPack plug-in modules across the TI ecosystem.

Pinout Diagram for your BoosterPack

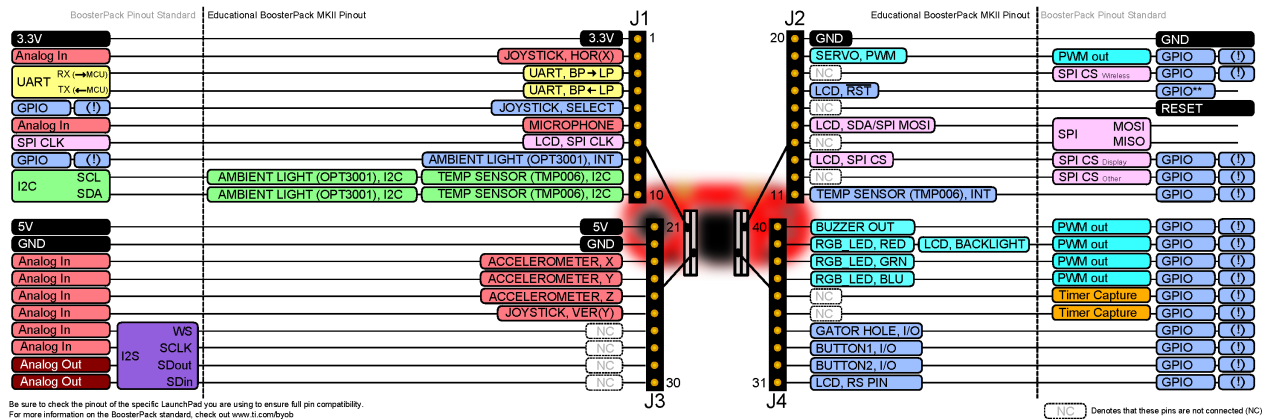

Figure 2-2. BoosterPack Plug-in Module Pinout

The 40-pin standard is compatible with the 20-pin standard that is used by other LaunchPad development kits like the MSP-EXP430G2. This allows for 20-pin LaunchPad development kits to be used with 40-pin BoosterPack plug-in modules with some limited functionality.

The BOOSTXL-EDUMKII supports BoosterPack plug-in module stacking with its male and female BoosterPack plug-in module headers. See how many BoosterPack plug-in modules you can stack onto your LaunchPad development kit to add more functionality like wireless and battery power.

More information about compatibility can also be found at <http://www.ti.com/launchpad>.

2.1.2 TI OPT3001 Light Sensor

The OPT3001 is a digital ambient light sensor (ALS) that measures the intensity of light as visible by the human eye. Covering the sensor with your finger or shining a flashlight on it will change the output of the OPT3001. The digital output is reported over an I²C- and SMBus-compatible, two-wire serial interface. The reference designator for the OPT3001 is U2.

More information on the OPT3001 light sensor can be found at <http://www.ti.com/product/opt3001>.

Table 2-1. OPT3001 Pinout

BoosterPack Plug-in Module Header Connection	Pin Function
J1.8	OPT3001 interrupt
J1.9 ⁽¹⁾	I ² C SCL
J1.10 ⁽¹⁾	I ² C SDA

(1) Pin is multiplexed with the I²C communication lines of the TMP006.

2.1.3 TI TMP006 Temperature Sensor

Note

The TMP006 was discontinued in 2017. Therefore, it is no longer populated on the board. Documentation of the TMP006 is unchanged in this user's guide to accommodate users who still have the device populated on the board.

The TMP006 is a digital infrared (IR) thermopile contactless temperature sensor that measures the temperature of an object without being in direct contact. Placing your hand over the sensor increases the sensor output. The digital output is reported over an I²C- and SMBus-compatible two-wire serial interface. The reference designator for the TMP006 is U1.

More information on the TMP006 temperature sensor can be found at <http://www.ti.com/product/tmp006>.

Table 2-2. TMP006 Pinout

BoosterPack Plug-in Module Header Connection	Pin Function
J1.9 ⁽¹⁾	I ² C SCL
J1.10 ⁽¹⁾	I ² C SDA
J2.11	TMP006 Interrupt

(1) Pin is multiplexed with the I²C communication lines of the OPT3001.

2.1.4 Servo Motor Connector

The servo motor connector is a 3-pin header for the user to connect an external servo to be controlled. Users can connect a servo and control it through the application code. The reference designator for the servo motor connector is J8.

Table 2-3. Servo Motor Connector Pinout

BoosterPack Plug-in Module Header Connection	Pin Function
J2.19	Servo Signal

Note

This kit does not include a servo motor and the user must provide one.

2.1.5 3-Axis Accelerometer

The Kionix KXTC9-2050 is a 3-axis analog accelerometer that measures g-forces. Moving the board along the axes will change the analog signal generated by the accelerometer. The reference designator for the accelerometer is U3.

More information on the 3-axis accelerometer can be found at <http://www.kionix.com/product/KXTC9-2050>.

Table 2-4. 3-Axis Accelerometer Pinout

BoosterPack Plug-in Module Header Connection	Pin Function
J3.23	Accelerometer X-axis
J3.24	Accelerometer Y-axis
J3.25	Accelerometer Z-axis

2.1.6 RGB Multicolor LED

The Cree CLV1A-FKB RGB multicolor LED light output can make any color by mixing red, green, and blue. Each color channel can be individually modified by pulse width modulation (PWM) to achieve the desired color. The reference designator for the RGB LED is D1.

More information on the RGB multicolor LED can be found at <http://www.cree.com/LED-Components-and-Modules/Products/High-Brightness/SMD-Color/SMD-Full-Color>.

Table 2-5. RGB LED Pinout

BoosterPack Plug-in Module Header Connection	Pin Function
J4.37	Blue channel
J4.38	Green channel
J4.39 ⁽¹⁾	Red channel

(1) Pin is multiplexed with the LCD backlight pin through the jumper header J5.

2.1.7 Piezo Buzzer

The CUI CEM-1203(42) piezo buzzer can play various frequencies based on the user-provided PWM signal. You can even play different tones back to back to create a song. The reference designator for the piezo buzzer is BUZ1.

More information on the piezo buzzer can be found at [http://www.cui.com/product/components/buzzers/audio-transducers/magnetic/cem-1203\(42\)](http://www.cui.com/product/components/buzzers/audio-transducers/magnetic/cem-1203(42)).

Table 2-6. Piezo Buzzer Pinout

BoosterPack Plug-in Module Header Connection	Pin Function
J4.40	Buzzer input

2.1.8 Color 128x128-Pixel TFT LCD Display

The Crystalfontz CFAF128128B-0145T color 128x128-pixel TFT LCD supports display updates up to 20 frames per second (FPS) while only requiring a few lines to control the TFT LCD module through the SPI interface. This module has a color depth of 262K colors and a contrast ratio of 350. The reference designator for the color LCD is LCD1.

More information on the color LCD can be found at <https://www.crystalfontz.com/product/cfaf128128b0145t-graphical-tft-128x128-lcd-display-module>.

Table 2-7. Color LCD Pinout

BoosterPack Plug-in Module Header Connection	Pin Function
J1.7	LCD SPI clock
J2.13	LCD SPI chip select
J2.15	LCD SPI MOSI
J4.17	LCD reset pin
J4.31	LCD register select pin
J4.39 ⁽¹⁾	LCD backlight

(1) Pin is multiplexed with the RGB LED red channel pin through the jumper header J5.

2.1.9 Microphone

The CUI CMA-4544PF-W electret microphone uses an OPA344 operational amplifier to boost the output of the microphone. The human ear can hear frequencies between 0 and 20 kHz and the operating range of the microphone is 20 Hz to 20 kHz. The reference designator for the microphone is MIC1.

More information on the microphone can be found at <http://www.cui.com/product/components/microphones/electret-condenser-microphone/cma-4544pf-w>.

Table 2-8. RGB LED Pinout

BoosterPack Plug-in Module Header Connection	Pin Function
J1.6	Microphone Output

2.1.10 2-Axis Joystick With Pushbutton

The ITEAD studio IM130330001 2-axis joystick with pushbutton is simply two potentiometers, one for each axis. The select button is actuated when the joystick is pressed down. The analogRead statement reads the voltage present on the joystick axis to provide the position of the joystick to the application (for example, pushing the joystick to the left reads X = 0). The reference designator for the analog joystick is JS1.

More information on the analog joystick can be found at <http://imall.itead.cc/playstation2-analog-joystick.html>.

Table 2-9. Joystick Pinout

BoosterPack Plug-in Module Header Connection	Pin Function
J1.2	Horizontal X-axis
J1.5	Select button
J3.26	Vertical Y-axis

2.1.11 User Pushbuttons

The user pushbuttons on the BOOSTXL-EDUMKII are connected to pullup resistors that drive the BoosterPack plug-in module pin high until the button is pressed and the pin is driven low. The reference designators for the user pushbuttons are S1 and S2.

Table 2-10. User Pushbuttons Pinout

BoosterPack Plug-in Module Header Connection	Pin Function
J4.32	S2 button
J4.33	S1 button

2.2 Power

The board was designed to be powered by the attached LaunchPad development kit, and requires both 3.3-V and 5-V power rails. Some 20-pin LaunchPad development kits like [MSP-EXP430FR4133](#) may not provide the necessary 5-V power, which will limit the functionality.

2.3 Design Files

2.3.1 Hardware

Schematics can be found in [Section 5](#). All design files including schematics, layout, bill of materials (BOM), Gerber files, and documentation are available in the BOOSTXL-EDUMKII Hardware Design Files on the [download page](#).

2.3.2 Software

All design files including TI-TXT object-code firmware images, software example projects, and documentation are available in the LaunchPad development kit specific software folders. To see which LaunchPad development kits feature BOOSTXL-EDUMKII examples, check the [download page](#).

2.3.3 Quick Start Guide

The Quick Start Guide is available from www.ti.com.

2.4 Hardware Change log

Table 2-11. Hardware Change Log

PCB Revision	Description
Rev 1.0	Initial release
Rev 1.1	Updates for CE compliance

3 Software Examples

Five software examples are included with the MSP-EXP432P401R LaunchPad development kit for the Educational BoosterPack plug-in module MKII (see [Table 3-1](#)). These examples can be found in the [MSP-EXP432P401R Software Examples](#), or they are more easily accessible through the [SimpleLink MSP432™ software development kit \(SDK\)](#) (see [Section 4.3](#)).

Table 3-1. Software Examples

Demo Name	LaunchPad Development Kit / BoosterPack Plug-in Module Required	Description	More Details
BOOSTXL-EDUMKII_Accelerometer_MSP432P401R	MSP-EXP432P401R / BOOSTXL-EDUMKII	Demonstrates how to sample data from the analog accelerometer sensor using the MSP432 ADC14	Section 3.1
BOOSTXL-EDUMKII_JoyStick_MSP432P401R	MSP-EXP432P401R / BOOSTXL-EDUMKII	Demonstrates how to sample data from the analog joystick using the MSP432 ADC14	Section 3.2
BOOSTXL-EDUMKII_LightSensor_MSP432P401R	MSP-EXP432P401R / BOOSTXL-EDUMKII	Demonstrates how to communicate with the digital ambient light sensor through I ² C using MSP432	Section 3.3
BOOSTXL-EDUMKII_Temperature_MSP432P401R	MSP-EXP432P401R / BOOSTXL-EDUMKII	Demonstrates how to communicate with the digital temperature sensor through I ² C using MSP432	Section 3.4
BOOSTXL-EDUMKII_MicrophoneFFT_MSP432P401R	MSP-EXP432P401R / BOOSTXL-EDUMKII	Demonstrates how to sample audio and perform FFT using the ARM CMSIS DSP Software Library	Section 3.5

To use any of the software examples with the LaunchPad development kit, you must have an integrated development environment (IDE) that supports the MSP432P401R device (see [Table 3-2](#)). For more details on how to get started quickly, and where to download the latest Code Composer Studio, IAR, and Keil IDEs, see [Section 4](#).

Table 3-2. IDE Minimum Requirements for MSP-EXP432P401R

Code Composer Studio™ IDE	IAR Embedded Workbench® IDE	Keil® µVision® MDK-ARM
v7.1.0	v7.80.3	v5

3.1 BOOSTXL-EDUMKII_Accelerometer_MSP432P401R

This section describes the functionality and structure of the BOOSTXL-EDUMKII_Accelerometer_MSP432P401R demo that is included in the [MSP-EXP432P401R Software Examples](#) download, or more easily accessible through the [SimpleLink MSP432 SDK](#) (see [Section 4.3](#)).

3.1.1 Source File Structure

The project is split into multiple files (see [Table 3-3](#)). This makes it easier to navigate and reuse parts of it for other projects.

Table 3-3. Source File and Folders

Name	Description
main.c	The demo's main function, interrupt service routines, global variables, and so on
msp432_startup_ccs.c	MSP432 family interrupt vector table for CGT
Library: GrLib	MSP Graphics Library
Library: driverlib	Device driver library (MSP432DRIVERLIB)
Driver: LcdDriver	LCD specific driver files

3.1.2 Operation

This demo uses the MSP432 built-in ADC14 to sample from the 3-axis acceleration data output of the analog accelerometer on the Educational BoosterPack plug-in module MKII (see [Figure 3-1](#)). The measured 14-bit acceleration data are displayed on the BoosterPack plug-in module's colored 128x128 dot-matrix LCD. Using [MSP Graphics Library](#), the MSP432 MCU sends data to the LCD controller through SPI communication to draw texts.

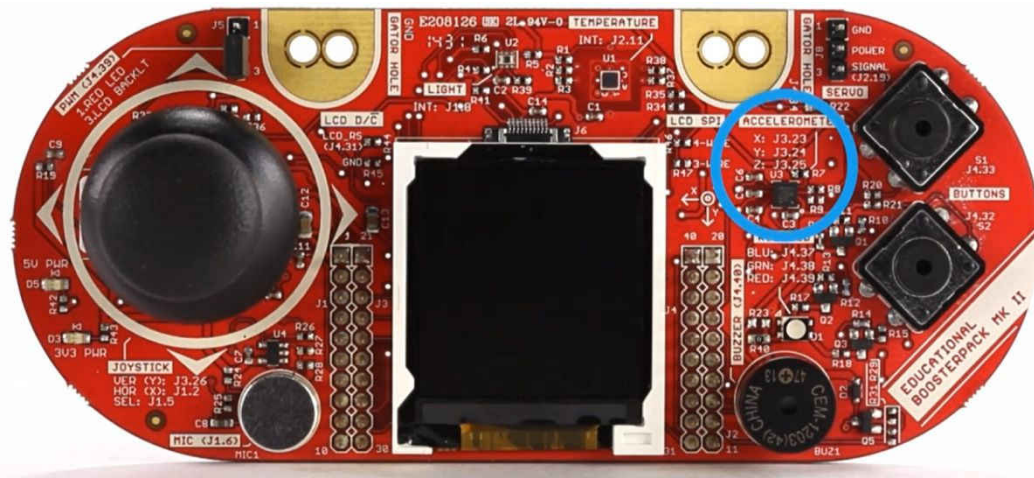

Figure 3-1. 3-Axis Analog Accelerometer

The demo makes use of the acceleration data by changing the LCD orientation when the BoosterPack plug-in module is tilted in the corresponding direction.

3.2 BOOSTXL-EDUMKII_JoyStick_MSP432P401R

This section describes the functionality and structure of the BOOSTXL-EDUMKII_JoyStick_MSP432P401R demo that is included in the [MSP-EXP432P401R Software Examples](#) download, or more easily accessible through the [SimpleLink MSP432 SDK](#) (see [Section 4.3](#)).

3.2.1 Source File Structure

The project is divided into multiple files (see [Table 3-4](#)). This makes it easier to navigate and reuse parts of it for other projects.

Table 3-4. Source File and Folders

Name	Description
main.c	The demo's main function, interrupt service routines, global variables, and so on
mcp432_startup_ccs.c	MSP432 family interrupt vector table for CGT
Library: GrLib	MSP Graphics Library
Library: driverlib	Device driver library (MSP432DRIVERLIB)
Driver: LcdDriver	LCD specific driver files

3.2.2 Operation

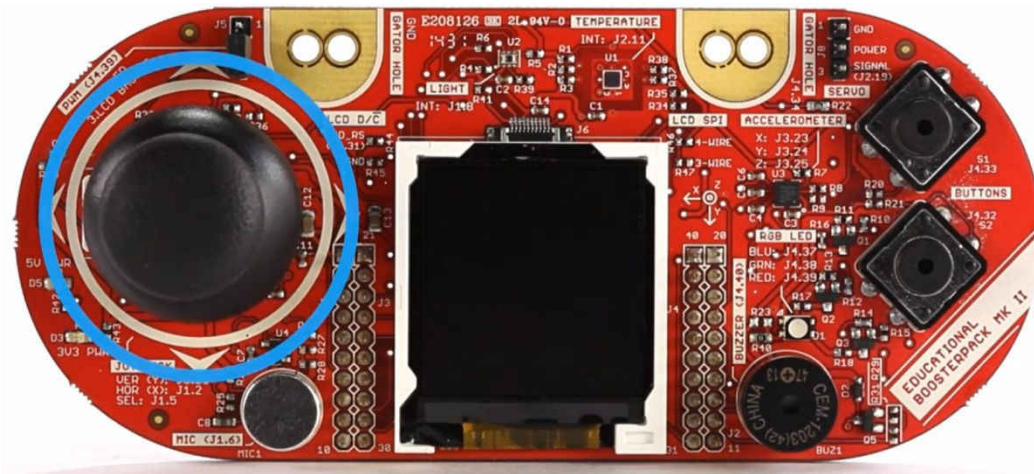

Figure 3-2. 2-Axis Analog Joystick With Digital Input

This demo uses the MSP432 built-in ADC14 to sample from the 2-axis of the analog joystick on the Educational BoosterPack plug-in module MKII. The measured 14-bit X and Y axis data are displayed on the BoosterPack plug-in module's colored 128x128 dot-matrix LCD. Using [MSP Graphics Library](#), the MSP432 MCU sends data to the LCD controller through SPI communication to draw texts.

3.3 BOOSTXL-EDUMKII_LightSensor_MSP432P401R

This section describes the functionality and structure of the BOOSTXL-EDUMKII_LightSensor_MSP432P401R demo that is included in the [MSP-EXP432P401R Software Examples](#) download, or more easily accessible through the [SimpleLink MSP432 SDK](#) (see [Section 4.3](#)).

3.3.1 Source File Structure

The project is split into multiple files (see [Table 3-5](#)). This makes it easier to navigate and reuse parts of it for other projects.

Table 3-5. Source File and Folders

Name	Description
main.c	The demo's main function, interrupt service routines, global variables, and so on
msp432_startup_ccs.c	MSP432 family interrupt vector table for CGT
Library: GrLib	MSP Graphics Library
Library: driverlib	Device driver library (MSP432DRIVERLIB)
Driver: LcdDriver	LCD specific driver files
Driver: HAL_I2C.c	Generic I2C driver file
Driver: HAL_OPT3001.c	OPT3001 sensor specific driver built on top of the HAL_I2C driver

3.3.2 Operation

This demo uses the MSP432 built-in eUSCI module in I²C mode to initialize and gather data from the digital ambient light sensor, OPT3001, on the Educational BoosterPack plug-in module MKII (see [Figure 3-3](#)). The measured illuminance value (Lux) is displayed on the colored 128x128 dot-matrix LCD of the BoosterPack plug-in module. Using [MSP Graphics Library](#), the MSP432 MCU sends data to the LCD controller through SPI communication to draw texts.

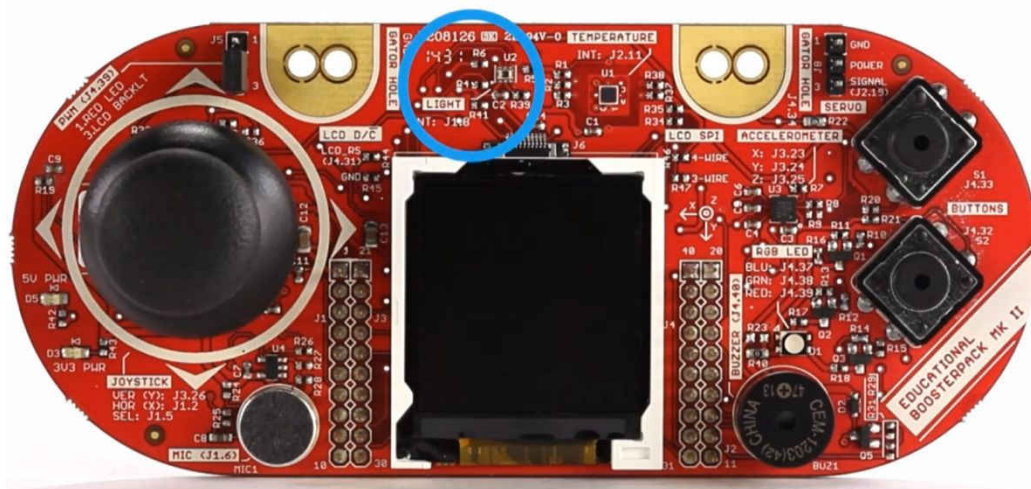

Figure 3-3. OPT3001 Ambient Light Sensor

The demo also controls the brightness of the LCD backlight LED by generating a Timer PWM.

Note

Make sure that the **J5 jumper** on the BOOSTXL-EDUMKII is connected to **3.LCD BACKLIT**

The demo makes use of the illuminance value by brightening the LCD backlight when high illuminance value is detected, or by dimming the LCD backlight when low illuminance value is detected.

3.4 BOOSTXL-EDUMKII_Temperature_MSP432P401R

This section describes the functionality and structure of the BOOSTXL-EDUMKII_Temperature_MSP432P401R demo that is included in the [MSP-EXP432P401R Software Examples](#) download, or more easily accessible through the [SimpleLink MSP432 SDK](#) (see [Section 4.3](#)).

3.4.1 Source File Structure

The project is split into multiple files (see [Table 3-6](#)). This makes it easier to navigate and reuse parts of it for other projects.

Table 3-6. Source File and Folders

Name	Description
main.c	The demo's main function, interrupt service routines, global variables, and so on
mcp432_startup_ccs.c	MSP432 family interrupt vector table for CGT
Library: GrLib	MSP Graphics Library
Library: driverlib	Device driver library (MSP432DRIVERLIB)
Driver: LcdDriver	LCD specific driver files
Driver: HAL_I2C.c	Generic I2C driver file
Driver: HAL_TMP006.c	TMP006 sensor specific driver built on top of the HAL_I2C driver

3.4.2 Operation

This demo uses the MSP432 built-in eUSCI module in I²C mode to initialize and gather data from the digital infrared temperature sensor, TMP006, on the Educational BoosterPack plug-in module MKII (see [Figure 3-4](#)). The measured temperature (°F) is displayed on the colored 128x128 dot-matrix LCD of the BoosterPack plug-in module.

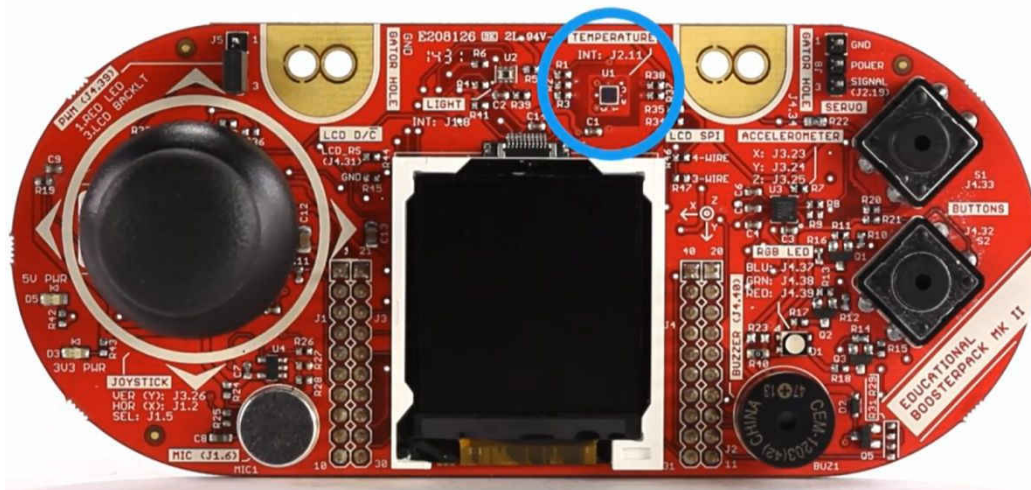

Figure 3-4. TMP006 Infrared Contactless Temperature Sensor

3.5 BOOSTXL-EDUMKII_MicrophoneFFT_MSP432P401R

This section describes the functionality and structure of the BOOSTXL-EDUMKII_MicrophoneFFT_MSP432P401R demo that is included in the [MSP-EXP432P401R Software Examples](#) download, or more easily accessible through the [SimpleLink MSP432 SDK](#) (see [Section 4.3](#)).

3.5.1 Source File Structure

The project is split into multiple files (see [Table 3-7](#)). This makes it easier to navigate and reuse parts of it for other projects.

Table 3-7. Source File and Folders

Name	Description
main.c	The demo's main function, interrupt service routines, global variables, and so on
msp432_startup_ccs.c	MSP432 Family Interrupt Vector Table for CGT
Library: GrLib	MSP Graphics Library
Library: driverlib	Device driver library (MSP432DRIVERLIB)
Driver: LcdDriver	LCD specific driver files
Driver: HAL_I2C.c	Generic I2C driver file
Driver: HAL_OPT3001.c	OPT3001 sensor specific driver built on top of the HAL_I2C driver

3.5.2 Operation

This demo visualizes 512-point real FFT results calculated from audio samples gathered in real-time from the onboard microphone of the Educational BoosterPack plug-in module MKII (see [Figure 3-5](#)). The demo uses the real FFT function contained in the CMSIS DSP Software Library.

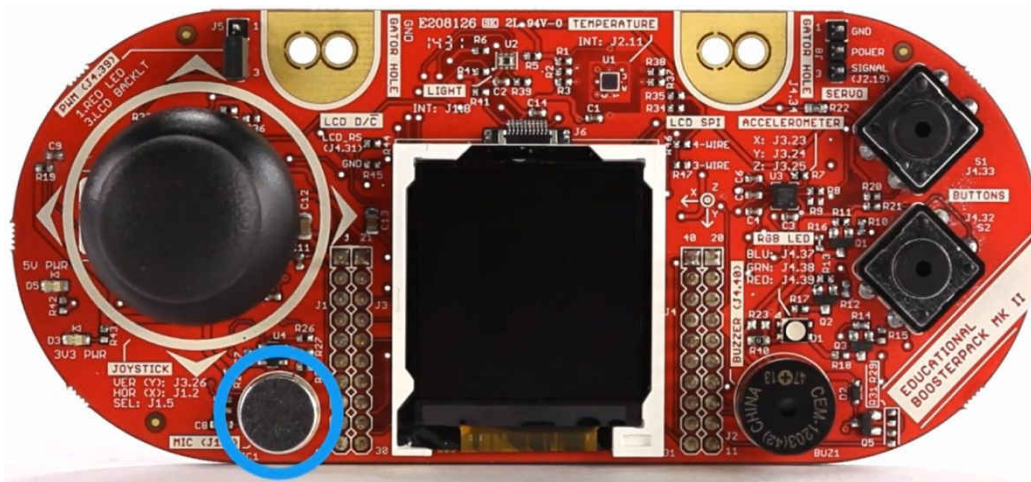

Figure 3-5. Microphone

The program begins by using the MSP432 built-in ADC14 module to sample audio signal at 8 KHz from the microphone on the Educational BoosterPack plug-in module MKII. To achieve seamless data processing, the MSP432 built-in DMA module is set up in Ping-Pong mode to alternate between two data buffers. This allows the ADC14 module to continue gathering audio data into one buffer, while the MSP432 runs the FFT algorithm on the other buffer.

When the DMA module completes data transfers from ADC14 results to one of the 512 length data buffers, an interrupt is triggered to wake the MSP432 from LPM0 sleep mode to initiate the 512-point real FFT calculation. The resulting frequency bin data is displayed in a bar graph on the BoosterPack plug-in module's colored 128x128 dot-matrix LCD using [MSP Graphics Library](#).

Try generating a pure tone ranging from 1 Hz to 4000 Hz and see if the demo shows the correct frequency.

3.5.3 CMSIS DSP Software Library in MSP432

This demo uses a pre-built CMSIS DSP Software Library file. However, a separate project, **dsplib-msp432**, is included in the [MSP-EXP432P401R Software Examples](#) download, showing how to compile the ARM [CMSIS DSP Software Library](#) with a MSP432 device in Code Composer Studio IDE.

It opens up access to the suite of signal processing functions in the CMSIS DSP Software Library for MSP432 MCUs inside the Code Composer Studio development environment.

4 Additional Resources

4.1 TI LaunchPad Development Kit Portal

More information about LaunchPad development kits, supported BoosterPack plug-in modules, and available resources can be found at:

- [TI's LaunchPad portal](#): information about all LaunchPad development kits from TI, for all MCUs

4.2 Download Code Composer Studio IDE, IAR, or Energia

Although the files can be viewed with any text editor, more can be done with the projects if they are opened with a [development environment](#) like Code Composer Studio IDE, IAR, or Energia.

4.3 SimpleLink MSP432 SDK and TI Resource Explorer

The MSP432 device is part of the SimpleLink microcontroller (MCU) platform, which consists of Wi-Fi®, Bluetooth® low energy, Sub-1 GHz, and host MCUs. All share a common, easy-to-use development environment with a single core software development kit (SDK) and rich tool set. A one-time integration of the SimpleLink platform lets you add any combination of devices from the portfolio into your design. The ultimate goal of the SimpleLink platform is to achieve 100 percent code reuse when your design requirements change. For more information, visit www.ti.com/simplelink.

The SimpleLink MSP432 SDK is included in the TI Resource Explorer for easily browsing tools, documents, examples, and more (see [Figure 4-1](#)).

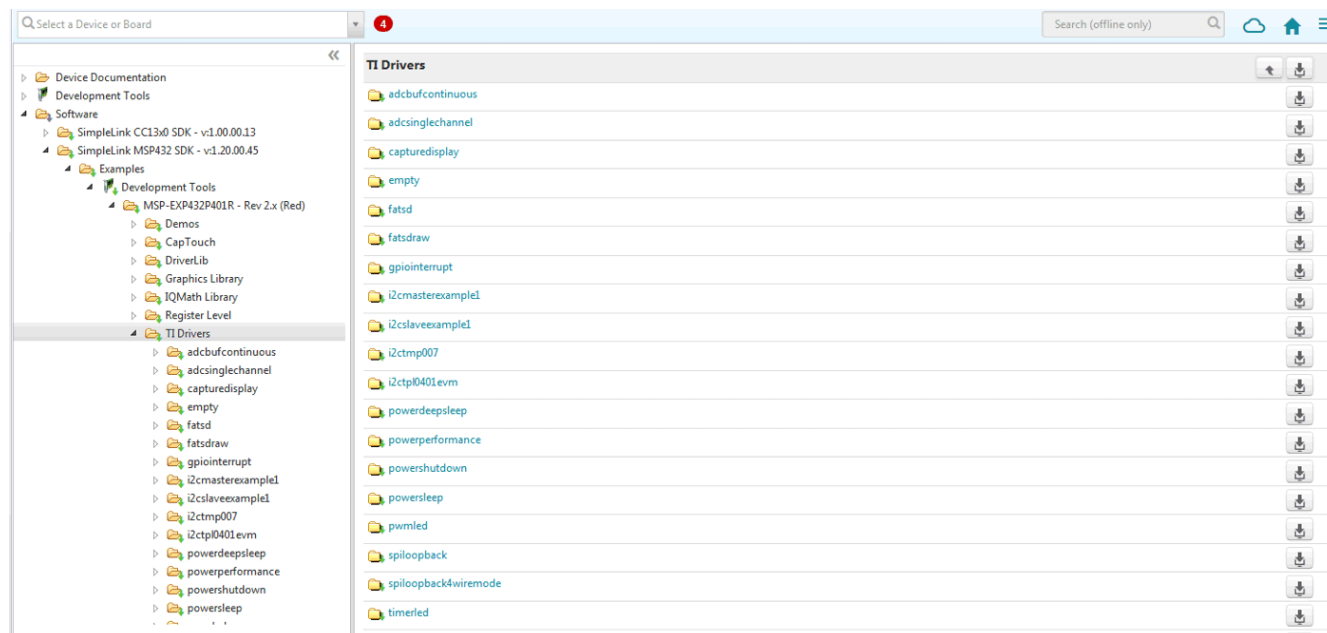

Figure 4-1. TI Drivers Software Examples in TI Resource Explorer

Inside TI Resource Explorer, these examples and many more can be found and easily imported into Code Composer Studio IDE with one click.

4.4 The Community

4.4.1 TI E2E™ Community

Search the TI E2E™ community forums at <http://e2e.ti.com>. If you cannot find your answer, post your question to the community.

4.4.2 Community at Large

Many online communities focus on the LaunchPad development kit and BoosterPack plug-in module ecosystem – for example, <http://www.43oh.com>. You can find additional tools, resources, and support from these communities.

5 Schematics

Figure 5-1 and Figure 5-2 show the schematics. All hardware design files can be found on the [download page](#).

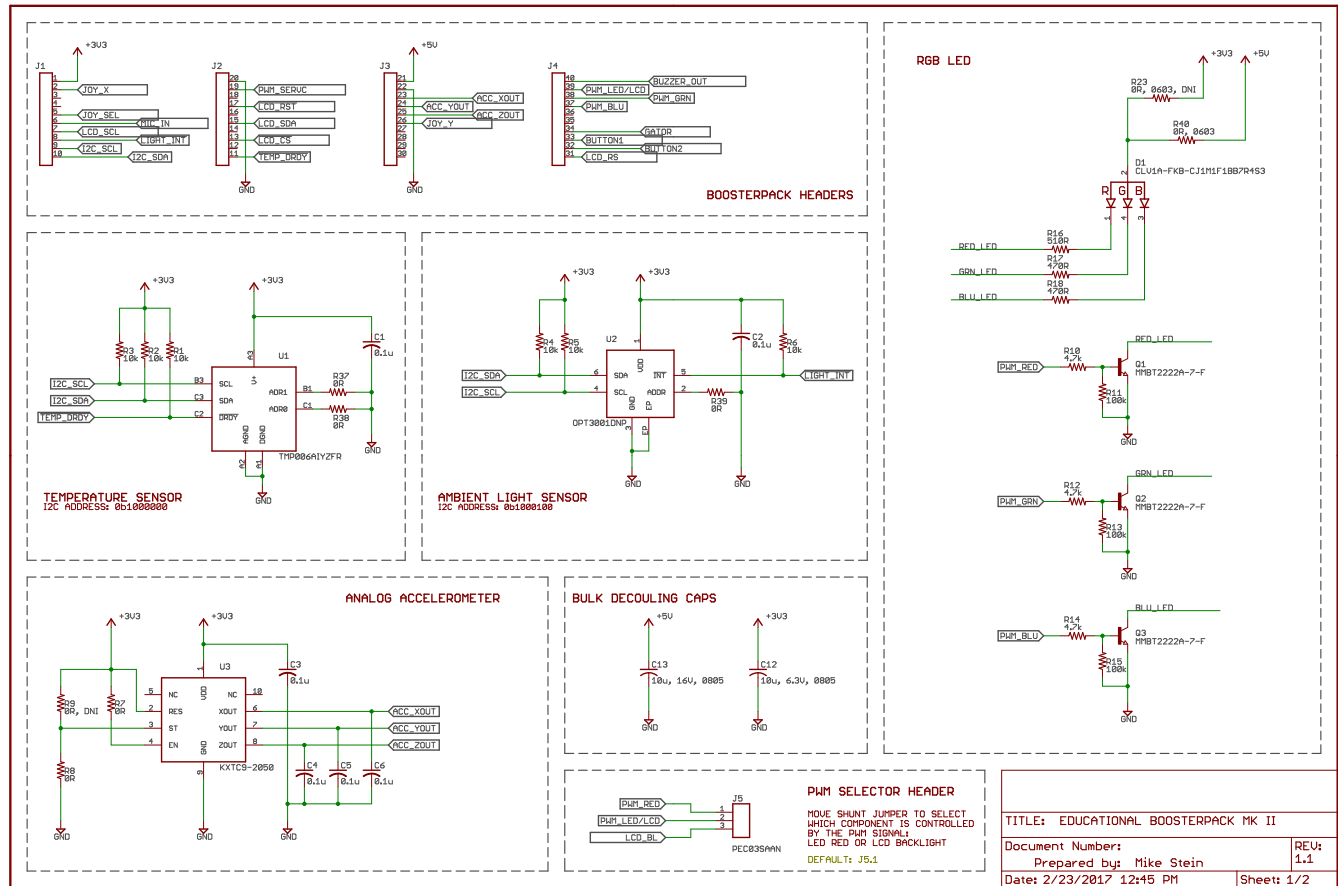

Figure 5-1. Schematics (1 of 2)

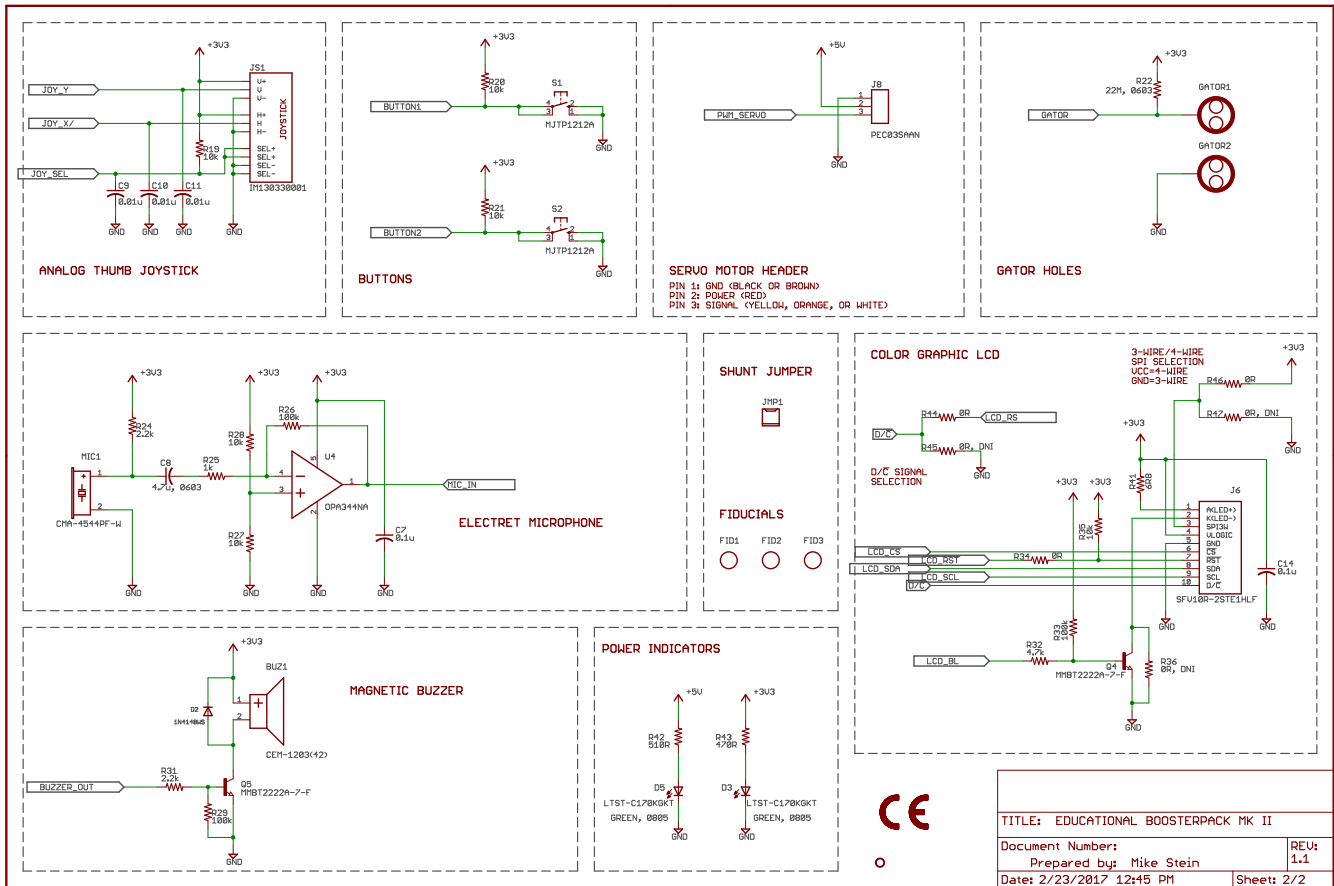

Figure 5-2. Schematics (2 of 2)

6 Revision History

Changes from March 7, 2017 to July 12, 2021

	Page
• Updated the numbering format for tables, figures, and cross references throughout the document.....	1
• Added note about TMP006 being discontinued in Section 2.1.3 TI TEMP006 Temperature Sensor	6
• Corrected Table 2-7 Color LCD Pinout	7

IMPORTANT NOTICE AND DISCLAIMER

TI PROVIDES TECHNICAL AND RELIABILITY DATA (INCLUDING DATA SHEETS), DESIGN RESOURCES (INCLUDING REFERENCE DESIGNS), APPLICATION OR OTHER DESIGN ADVICE, WEB TOOLS, SAFETY INFORMATION, AND OTHER RESOURCES "AS IS" AND WITH ALL FAULTS, AND DISCLAIMS ALL WARRANTIES, EXPRESS AND IMPLIED, INCLUDING WITHOUT LIMITATION ANY IMPLIED WARRANTIES OF MERCHANTABILITY, FITNESS FOR A PARTICULAR PURPOSE OR NON-INFRINGEMENT OF THIRD PARTY INTELLECTUAL PROPERTY RIGHTS.

These resources are intended for skilled developers designing with TI products. You are solely responsible for (1) selecting the appropriate TI products for your application, (2) designing, validating and testing your application, and (3) ensuring your application meets applicable standards, and any other safety, security, regulatory or other requirements.

These resources are subject to change without notice. TI grants you permission to use these resources only for development of an application that uses the TI products described in the resource. Other reproduction and display of these resources is prohibited. No license is granted to any other TI intellectual property right or to any third party intellectual property right. TI disclaims responsibility for, and you will fully indemnify TI and its representatives against, any claims, damages, costs, losses, and liabilities arising out of your use of these resources.

TI's products are provided subject to [TI's Terms of Sale](#) or other applicable terms available either on ti.com or provided in conjunction with such TI products. TI's provision of these resources does not expand or otherwise alter TI's applicable warranties or warranty disclaimers for TI products.

TI objects to and rejects any additional or different terms you may have proposed.

Mailing Address: Texas Instruments, Post Office Box 655303, Dallas, Texas 75265
Copyright © 2022, Texas Instruments Incorporated

Looking for pricing, stock, or lifecycle information?

Click below to explore more details on WIN SOURCE:

 [View BOOSTXL-EDUMKII on WIN SOURCE](#)

 [Texas Instruments](#) Information

Optimize Your Supply Chain with WIN SOURCE Solutions

-  Global Sourcing Solution
-  Obsolete Management
-  Cost Control Management
-  Shortage Management
-  Alternative Solution
-  Excess Inventory Management