

202 Series Fuse



Agency Approvals

AGENCY	AGENCY FILE/ CERTIFICATE NUMBER	AMPERE RANGE
	E10480	0.063 A-5 A
	29862	0.063 A-5 A

Electrical Characteristics for Series

% of Ampere Rating	Opening Time
100%	4 hours, Minimum
200%	2 seconds, Maximum

Description

Fast-Acting and Slo-Blo® Fuse versions of the Flat-Pak® Fuse designs are available. Both designs are available in either a gull-wing surface mount package or a DIP configuration for through-hole mounting. These fuse designs feature a 250 VAC rating in a low profile, rectangular package.

Product Characteristics

Materials	Body: Thermoplastic Terminations: Tin/Lead Plated Copper
Solderability	MIL-STD-202, Method 208
Cleaning	Board washable in most common solvents
Operating Temperature	-55 °C to 125 °C

Part Numbering System

Surface Mount Fuses:

0202 002. HXG

Series _____
Amp Code _____
Refer to Amp Code column of Electrical Characteristics Table

Quantity Code _____
HXG = 100
URG = 500

Through-Hole Fuses:

0202 002. H

Series _____
Amp Code _____
Refer to Amp Code column of Electrical Characteristics Table

Quantity Code _____
H = 100

Electrical Specifications by Item

Ampere Rating (A)	Amp Code	Max Voltage Rating (V)	Interrupting Rating	Nominal Cold Resistance (Ohms)	Nominal Melting I ² t (A ² sec)	Agency Approvals	
0.062	.062	250	50A@250VAC	7.9000	0.000220	x	x
0.125	.125	250		2.4500	0.00180	x	x
0.250	.250	250		0.8800	0.0147	x	x
0.500	.500	250		0.2980	0.0363	x	x
0.750	.750	250		0.1660	0.0980	x	x
1.00	001.	250		0.1190	0.192	x	x
1.50	01.5	250		0.0701	0.540	x	x
2.00	002.	250		0.0469	1.07	x	x
2.50	02.5	250		0.0455	1.76	x	x
3.00	003.	250		0.0327	1.71	x	x
4.00	004.	250		0.0244	3.00	x	x
5.00	005.	250		0.0174	4.68	x	x

Temperature Re-rating Curve

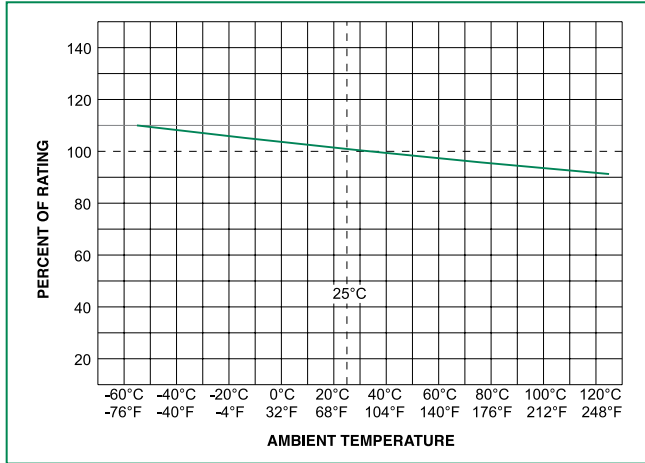

Note:

1. Re-rating depicted in this curve is in addition to the standard derating of 25% for continuous operation.

Soldering Parameters

Wave Soldering	260 °C, 3 seconds max.
Reflow Soldering	215 °C, 30 seconds max.

Dimensions mm (inch)

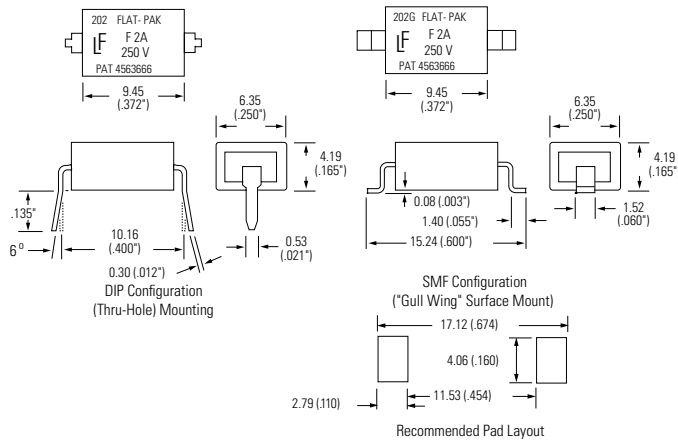

Average Time Current Curves

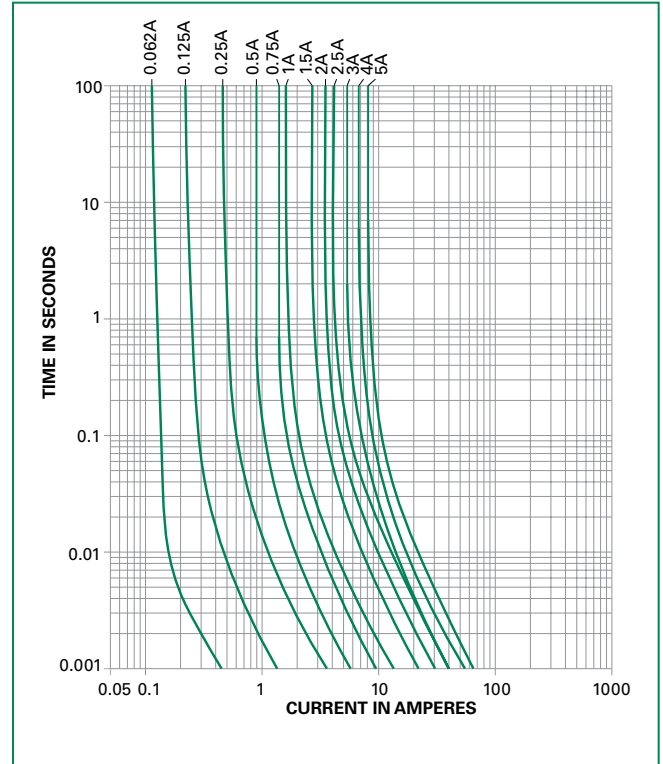

Packaging

Packaging Option	Packaging Specification	Quantity	Quantity & Packaging Code
Surface Mount Fuses			
Bulk	-	100	HXG
24mm Tape and Reel	EIA 481 (IEC 60286-3)	500	URG
Through Hole Fuses			
Antistatic Magazine	-	100	H

Disclaimer Notice - Information furnished is believed to be accurate and reliable. However, users should independently evaluate the suitability of and test each product selected for their own applications. Littelfuse products are not designed for, and may not be used in, all applications. Read complete Disclaimer Notice at: www.littelfuse.com/disclaimer-electronics.

Looking for pricing, stock, or lifecycle information?

Click below to explore more details on WIN SOURCE:

 [View 0202.250H on WIN SOURCE](#)

 [Littelfuse Inc. Information](#)

Optimize Your Supply Chain with WIN SOURCE Solutions

-  Global Sourcing Solution
-  Obsolete Management
-  Cost Control Management
-  Shortage Management
-  Alternative Solution
-  Excess Inventory Management