



**THE DATASHEET OF  
GT28F320B3TA100**





# 3-Volt Advanced Boot Block Flash Memory

28F008/800B3, 28F016/160B3, 28F320B3, 28F640B3

Datasheet

## Product Features

- Flexible SmartVoltage Technology
  - 2.7 V–3.6 V Read/Program/Erase
  - 12 V  $V_{PP}$  Fast Production Programming
- 1.65 V–2.5 V or 2.7 V–3.6 V I/O Option
  - Reduces Overall System Power
- High Performance
  - 2.7 V–3.6 V: 70 ns Max Access Time
- Optimized Block Sizes
  - Eight 8-KB Blocks for Data, Top or Bottom Locations
  - Up to One Hundred Twenty-Seven 64-KB Blocks for Code
- Block Locking
  - $V_{CC}$ -Level Control through WP#
- Low Power Consumption
  - 9 mA Typical Read Current
- Absolute Hardware-Protection
  - $V_{PP}$  = GND Option
  - $V_{CC}$  Lockout Voltage
- Extended Temperature Operation
  - -40 °C to +85 °C
- Automated Program and Block Erase
  - Status Registers
- Intel® Flash Data Integrator Software
  - Flash Memory Manager
  - System Interrupt Manager
  - Supports Parameter Storage, Streaming Data (e.g., Voice)
- Extended Cycling Capability
  - Minimum 100,000 Block Erase Cycles Guaranteed
- Automatic Power Savings Feature
  - Typical  $I_{CCS}$  after Bus Inactivity
- Standard Surface Mount Packaging
  - 48-Ball CSP Packages
  - 40- and 48-Lead TSOP Packages
- Density and Footprint Upgradeable for common package
  - 8-, 16-, 32- and 64-Mbit Densities
- ETOX™ VIII (0.13  $\mu$ m) Flash Technology
  - 16 and 32-Mbit Densities
- ETOX™ VII (0.18  $\mu$ m) Flash Technology
  - 16-, 32- and 64-Mbit Densities
- ETOX™ VI (0.25 $\mu$ m) Flash Technology
  - 8-, 16-, and 32-Mbit Densities
- The x8 option not recommended for new designs

The Intel® 3-Volt Advanced Boot Block flash memory, manufactured on Intel's latest 0.13  $\mu$ m and 0.18  $\mu$ m technologies, represent a feature-rich solution at overall lower system cost. The 3-Volt Advanced Boot Block Flash Memory products in x16 will be available in 48-lead TSOP and 48-ball CSP packages. The x8 option of this product family will be available only in 40-lead TSOP and 48-ball  $\mu$ BGA\* packages. Additional information on this product family can be obtained by accessing Intel's website at: <http://www.intel.com/design/flash>.

**Notice:** This specification is subject to change without notice. Verify with your local Intel sales office that you have the latest data sheet before finalizing a design.



Information in this document is provided in connection with Intel® products. No license, express or implied, by estoppel or otherwise, to any intellectual property rights is granted by this document. Except as provided in Intel's Terms and Conditions of Sale for such products, Intel assumes no liability whatsoever, and Intel disclaims any express or implied warranty, relating to sale and/or use of Intel products including liability or warranties relating to fitness for a particular purpose, merchantability, or infringement of any patent, copyright or other intellectual property right. Intel products are not intended for use in medical, life saving, or life sustaining applications.

Intel may make changes to specifications and product descriptions at any time, without notice.

Designers must not rely on the absence or characteristics of any features or instructions marked "reserved" or "undefined." Intel reserves these for future definition and shall have no responsibility whatsoever for conflicts or incompatibilities arising from future changes to them.

The 28F008/800B3, 28F016/160B3, 28F320B3, 28F640B3 may contain design defects or errors known as errata which may cause the product to deviate from published specifications. Current characterized errata are available on request.

Contact your local Intel sales office or your distributor to obtain the latest specifications and before placing your product order.

Copies of documents which have an ordering number and are referenced in this document, or other Intel literature may be obtained by calling 1-800-548-4725 or by visiting Intel's website at <http://developer.intel.com/design/flash>.

Copyright © Intel Corporation 1999– 2002.

\*Other names and brands may be claimed as the property of others.

# Contents

<b>1.0</b>	<b>Introduction</b> .....	1
1.1	Product Overview .....	2
<b>2.0</b>	<b>Product Description</b> .....	3
2.1	Package Pinouts .....	3
2.2	Block Organization .....	10
2.2.1	Parameter Blocks .....	10
2.2.2	Main Blocks .....	10
<b>3.0</b>	<b>Principles of Operation</b> .....	10
3.1	Bus Operation .....	10
3.1.1	Read .....	11
3.1.2	Output Disable .....	11
3.1.3	Standby .....	11
3.1.4	Deep Power-Down / Reset .....	11
3.1.5	Write .....	12
3.2	Modes of Operation .....	12
3.2.1	Read Array .....	12
3.2.2	Read Identifier .....	14
3.2.3	Read Status Register .....	14
3.2.3.1	Clearing the Status Register .....	14
3.2.4	Program Mode .....	15
3.2.4.1	Suspending and Resuming Program .....	15
3.2.5	Erase Mode .....	15
3.2.5.1	Suspending and Resuming Erase .....	16
3.3	Block Locking .....	17
3.3.1	WP# = $V_{IL}$ for Block Locking .....	17
3.3.2	WP# = $V_{IH}$ for Block Unlocking .....	18
3.4	$V_{PP}$ Program and Erase Voltages .....	18
3.4.1	$V_{PP} = V_{IL}$ for Complete Protection .....	18
3.5	Power Consumption .....	18
3.5.1	Active Power .....	19
3.5.2	Automatic Power Savings (APS) .....	19
3.5.3	Standby Power .....	19
3.5.4	Deep Power-Down Mode .....	19
3.6	Power and Reset Considerations .....	19
3.6.1	Power-Up/Down Characteristics .....	19
3.6.2	RP# Connected to System Reset .....	20
3.6.3	$V_{CC}$ , $V_{PP}$ and RP# Transitions .....	20
3.7	Power Supply Decoupling .....	20
<b>4.0</b>	<b>Electrical Specifications</b> .....	21
4.1	Absolute Maximum Ratings .....	21
4.2	Operating Conditions .....	22
4.3	Capacitance .....	22
4.4	DC Characteristics .....	23
4.5	AC Characteristics —Read Operations .....	27



4.6	AC Characteristics —Write Operations .....	32
4.7	Program and Erase Timings .....	36
<b>5.0</b>	<b>Reset Operations .....</b>	<b>38</b>
<b>6.0</b>	<b>Ordering Information .....</b>	<b>39</b>
<b>7.0</b>	<b>Additional Information .....</b>	<b>41</b>
<b>Appendix A</b>	<b>Write State Machine Current/Next States .....</b>	<b>42</b>
<b>Appendix B</b>	<b>Architecture Block Diagram .....</b>	<b>43</b>
<b>Appendix C</b>	<b>Word-Wide Memory Map Diagrams.....</b>	<b>44</b>
<b>Appendix D</b>	<b>Byte-Wide Memory Map Diagrams .....</b>	<b>50</b>
<b>Appendix E</b>	<b>Program and Erase Flowcharts .....</b>	<b>53</b>

# Revision History

Number	Description
-001	Original version
-002	<p>Section 3.4, <i>V<sub>PP</sub> Program and Erase Voltages</i>, added</p> <p>Updated Figure 9: <i>Automated Block Erase Flowchart</i></p> <p>Updated Figure 10: <i>Erase Suspend/Resume Flowchart</i> (added program to table)</p> <p>Updated Figure 16: <i>AC Waveform: Program and Erase Operations</i> (updated notes)</p> <p><i>I<sub>PPR</sub></i> maximum specification change from <math>\pm 25 \mu\text{A}</math> to <math>\pm 50 \mu\text{A}</math></p> <p>Program and Erase Suspend Latency specification change</p> <p>Updated Appendix A: <i>Ordering Information</i> (included 8 M and 4 M information)</p> <p>Updated Figure, Appendix D: <i>Architecture Block Diagram</i> (Block info. in words not bytes)</p> <p>Minor wording changes</p>
-003	<p>Combined byte-wide specification (previously 290605) with this document</p> <p>Improved speed specification to 80 ns (3.0 V) and 90 ns (2.7 V)</p> <p>Improved 1.8 V I/O option to minimum 1.65 V (Section 3.4)</p> <p>Improved several DC characteristics (Section 4.4)</p> <p>Improved several AC characteristics (Sections 4.5 and 4.6)</p> <p>Combined 2.7 V and 1.8 V DC characteristics (Section 4.4)</p> <p>Added 5 V <i>V<sub>PP</sub></i> read specification (Section 3.4)</p> <p>Removed 120 ns and 150 ns speed offerings</p> <p>Moved <i>Ordering Information</i> from Appendix to Section 6.0; updated information</p> <p>Moved <i>Additional Information</i> from Appendix to Section 7.0</p> <p>Updated figure Appendix B, <i>Access Time vs. Capacitive Load</i></p> <p>Updated figure Appendix C, <i>Architecture Block Diagram</i></p> <p>Moved Program and Erase Flowcharts to Appendix E</p> <p>Updated <i>Program Flowchart</i></p> <p>Updated <i>Program Suspend/Resume Flowchart</i></p> <p>Minor text edits throughout</p>
-004	<p>Added 32-Mbit density</p> <p>Added 98H as a reserved command (Table 4)</p> <p><math>A_1</math>–<math>A_{20} = 0</math> when in read identifier mode (Section 3.2.2)</p> <p>Status register clarification for SR3 (Table 7)</p> <p><i>V<sub>CC</sub></i> and <i>V<sub>CCQ</sub></i> absolute maximum specification = 3.7 V (Section 4.1)</p> <p>Combined <i>I<sub>PPW</sub></i> and <i>I<sub>CCW</sub></i> into one specification (Section 4.4)</p> <p>Combined <i>I<sub>PPE</sub></i> and <i>I<sub>CCE</sub></i> into one specification (Section 4.4)</p> <p>Max Parameter Block Erase Time (<math>t_{WHQV2}/t_{EHQV2}</math>) reduced to 4 sec (Section 4.7)</p> <p>Max Main Block Erase Time (<math>t_{WHQV3}/t_{EHQV3}</math>) reduced to 5 sec (Section 4.7)</p> <p>Erase suspend time @ 12 V (<math>t_{WHRH2}/t_{EHRH2}</math>) changed to 5 <math>\mu\text{s}</math> typical and 20 <math>\mu\text{s}</math> maximum (Section 4.7)</p> <p><i>Ordering Information</i> updated (Section 6.0)</p> <p>Write State Machine Current/Next States Table updated (Appendix A)</p> <p>Program Suspend/Resume Flowchart updated (Appendix F)</p> <p>Erase Suspend/Resume Flowchart updated (Appendix F)</p> <p>Text clarifications throughout</p>
-005	<p><math>\mu\text{BGA}</math> package diagrams corrected (Figures 3 and 4)</p> <p><i>I<sub>PPD</sub></i> test conditions corrected (Section 4.4)</p> <p>32-Mbit ordering information corrected (Section 6)</p> <p><math>\mu\text{BGA}</math> package top side mark information added (Section 6)</p>
-006	<p><i>V<sub>IH</sub></i> and <i>V<sub>IL</sub></i> Specification change (Section 4.4)</p> <p><i>I<sub>CCS</sub></i> test conditions clarification (Section 4.4)</p> <p>Added Command Sequence Error Note (Table 7)</p> <p>Data sheet renamed from <i>Smart 3 Advanced Boot Block 4-Mbit, 8-Mbit, 16-Mbit Flash Memory Family</i>.</p> <p>Added device ID information for 4-Mbit x8 device</p> <p>Removed 32-Mbit x8 to reflect product offerings</p> <p>Minor text changes</p>
-007	<p>Corrected RP# pin description in Table 2, <i>3 Volt Advanced Boot Block Pin Descriptions</i></p> <p>Corrected typographical error fixed in <i>Ordering Information</i></p>

Number	Description
-008	4-Mbit packaging and addressing information corrected throughout document
-009	Corrected 4-Mbit memory addressing tables in Appendices D and E
-010	Max I <sub>CCD</sub> changed to 25 $\mu$ A V <sub>CCMax</sub> on 32 M (28F320B3) changed to 3.3 V
-011	Added 64-Mbit density and faster speed offerings Removed access time vs. capacitance load curve
-012	Changed references of 32Mbit 80ns devices to 70ns devices to reflect the faster product offering. Changed V <sub>ccMax</sub> =3.3V reference to indicate the affected product is the 0.25 $\mu$ m 32Mbit device. Minor text edits throughout document.
-013	Added New Pin-1 indicator information on 40 and 48Lead TSOP packages. Minor text edits throughout document.
-014	Added specifications for 0.13 micron product offerings throughout document
-015	Minor text edits throughout document.
-016	Adjusted ordering information. Adjusted specifications for 0.13 micron product offerings. Revised and corrected DC Characteristics Table. Adjusted package diagram information. Minor text edits throughout document.

## 1.0 Introduction

This datasheet contains the specifications for the 3-Volt Advanced Boot Block Flash Memory family, which is optimized for portable, low-power, systems. This family of products features 1.65 V–2.5 V or 2.7 V–3.6 V I/Os, and a low  $V_{CC}/V_{PP}$  operating range of 2.7 V–3.6 V for Read, Program, and Erase operations. In addition, this family is capable of fast programming at 12 V. Throughout this document, the term “2.7 V” refers to the full voltage range 2.7 V–3.6 V (except where noted otherwise) and “ $V_{PP} = 12 V$ ” refers to 12 V  $\pm 5\%$ . Section 1.0 and 2.0 provide an overview of the Flash Memory family including applications, pinouts, and pin descriptions. Section 3.0 describes the memory organization and operation for these products. Sections 4.0 and 5.0 contain the operating specifications. Finally, Sections 6.0 and 7.0 provide ordering and other reference information.

The 3-Volt Advanced Boot Block Flash Memory features the following:

- Enhanced blocking for easy segmentation of code and data or additional design flexibility
- Program Suspend to Read command
- $V_{CCQ}$  input of 1.65 V–2.5 V or 2.7 V–3.6 V on all I/Os. See Figures 1 through 4 for pinout diagrams and  $V_{CCQ}$  location
- Maximum program and erase time specification for improved data storage.

**Table 1. 3-Volt Advanced Boot Block Feature Summary**

Feature	28F008B3, 28F016B3	28F800B3, 28F160B3, 28F320B3 <sup>(3)</sup> , 28F640B3	Reference
$V_{CC}$ Read Voltage	2.7 V– 3.6 V		Section 4.2, Section 4.4
$V_{CCQ}$ I/O Voltage	1.65 V–2.5 V or 2.7 V– 3.6 V		Section 4.2, 4.4
$V_{PP}$ Program/Erase Voltage	2.7 V– 3.6 V or 11.4 V– 12.6 V		Section 4.2, 4.4
Bus Width	8 bit	16 bit	Table 3
Speed	70 ns, 80 ns, 90 ns, 100 ns, 110 ns		Section 4.5
Memory Arrangement	1024 Kbit x 8 (8 Mbit), 2048 Kbit x 8 (16 Mbit)	512 Kbit x 16 (8 Mbit), 1024 Kbit x 16 (16 Mbit), 2048 Kbit x 16 (32 Mbit), 4096 Kbit x 16 (64 Mbit)	Section 2.2
Blocking (top or bottom)	Eight 8-Kbyte parameter blocks <b>and</b> Fifteen 64-Kbyte blocks (8 Mbit) or Thirty-one 64-Kbyte main blocks (16 Mbit) Sixty-three 64-Kbyte main blocks (32 Mbit) One hundred twenty-seven 64-Kbyte main blocks (64 Mbit)		Section 2.2 Appendix C
Locking	WP# locks/unlocks parameter blocks All other blocks protected using $V_{PP}$		Section 3.3 Table 8
Operating Temperature	Extended: –40 °C to +85 °C		Section 4.2, 4.4
Program/Erase Cycling	100,000 cycles		Section 4.2, 4.4
Packages	40-lead TSOP <sup>(1)</sup> , 48-Ball $\mu$ BGA* CSP <sup>(2)</sup>	48-Lead TSOP, 48-Ball $\mu$ BGA CSP <sup>(2)</sup> , 48-Ball VF BGA <sup>(4)</sup>	Figure 4, Figure 5

**NOTES:**

1. 32-Mbit and 64-Mbit densities not available in 40-lead TSOP.
2. 8-Mbit densities not available in  $\mu$ BGA\* CSP.
3.  $V_{CC}$ Max is 3.3 V on 0.25 $\mu$ m 32-Mbit devices.

## 1.1 Product Overview

Intel provides the most flexible voltage solution in the flash industry, providing three discrete voltage supply pins:  $V_{CC}$  for Read operation,  $V_{CCQ}$  for output swing, and  $V_{PP}$  for Program and Erase operation. All 3-Volt Advanced Boot Block Flash Memory products provide program/erase capability at 2.7 V or 12 V (for fast production programming), and read with  $V_{CC}$  at 2.7 V. Since many designs read from the flash memory a large percentage of the time, 2.7 V  $V_{CC}$  operation can provide substantial power savings.

The 3-Volt Advanced Boot Block Flash Memory products are available in either x8 or x16 packages in the following densities: (see [Section 6.0, “Ordering Information” on page 39](#) for availability.)

- 8-Mbit (8, 388, 608-bit) flash memory organized as 512 Kwords of 16 bits each or 1024 Kbytes of 8-bits each
- 16-Mbit (16, 777, 216-bit) flash memory organized as 1024 Kwords of 16 bits each or 2048 Kbytes of 8-bits each
- 32-Mbit (33, 554, 432-bit) flash memory organized as 2048 Kwords of 16 bits each
- 64-Mbit (67, 108, 864-bit) flash memory organized as 4096 Kwords of 16 bits each

The parameter blocks are located at either the top (denoted by -T suffix) or the bottom (-B suffix) of the address map in order to accommodate different microprocessor protocols for kernel code location. The upper two (or lower two) parameter blocks can be locked to provide complete code security for system initialization code. Locking and unlocking is controlled by WP# (see [Section 3.3, “Block Locking” on page 17](#) for details).

The Command User Interface (CUI) serves as the interface between the microprocessor or microcontroller and the internal operation of the flash memory. The internal Write State Machine (WSM) automatically executes the algorithms and timings necessary for Program and Erase operations, including verification, thereby unburdening the microprocessor or microcontroller. The status register indicates the status of the WSM by signifying block erase or word program completion and status.

The 3-Volt Advanced Boot Block flash memory is also designed with an Automatic Power Savings (APS) feature, which minimizes system current drain and allows for very low power designs. This mode is entered following the completion of a read cycle (approximately 300 ns later).

The RP# pin provides additional protection against unwanted command writes that may occur during system reset and power-up/down sequences due to invalid system bus conditions (see [Section 3.6, “Power-Up/Down Operation” on page 19](#)).

[Section 3.0, “Principles of Operation” on page 10](#) gives detailed explanation of the different modes of operation. [Section 4.4, “DC Characteristics” on page 23](#) provides complete current and voltage specifications. Refer to [Section 4.5, “AC Characteristics —Read Operations” on page 27](#) for read, program, and erase performance specifications.

## 2.0 Product Description

This section explains device pin description and package pinouts.

### 2.1 Package Pinouts

The 3-Volt Advanced Boot Block flash memory is available in 40-lead TSOP (x8, [Figure 1](#)), 48-lead TSOP (x16, [Figure 2](#)), 48-ball  $\mu$ BGA(x8 and x16, [Figure 4](#) and [Figure 5](#), respectively), and 48-ball VF BGA (x16, [Figure 5](#)) packages. In all figures, pin changes necessary for density upgrades have been circled.

**Figure 1. 40-Lead TSOP Package for x8 Configurations**

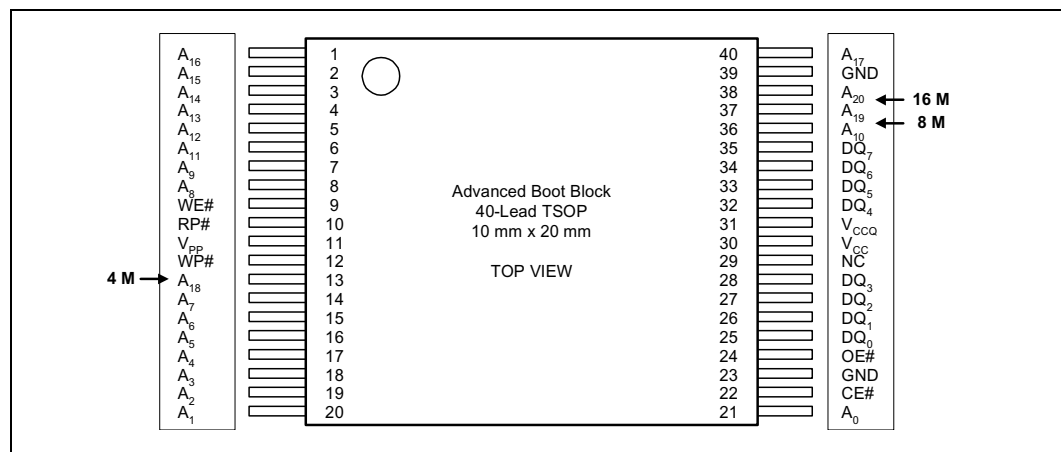

0580\_01

**NOTES:**

1. 40-Lead TSOP available for 8-Mbit and 16-Mbit densities only.
2. Lower densities will have NC on the upper address pins. For example, an 8-Mbit device will have NC on Pin 38.

Figure 2. 48-Lead TSOP Package for x16 Configurations

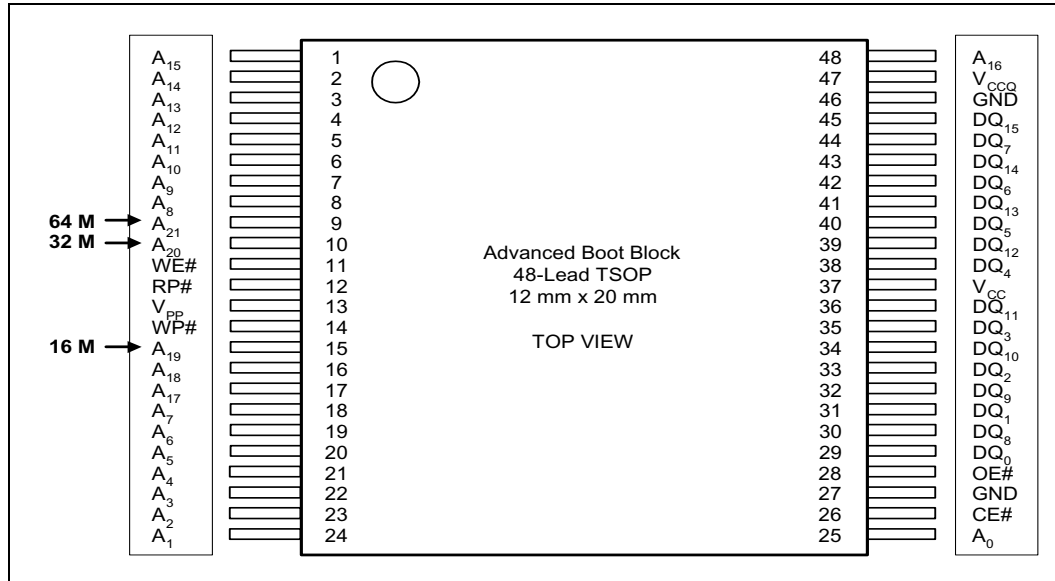

0580\_02

Figure 3. New Mark for Pin-1 indicator for 40-Lead 8 Mb, 16 Mb TSOP and 48-Lead 8 Mb, 16 Mb and 32 Mb TSOP

**Current Mark:**

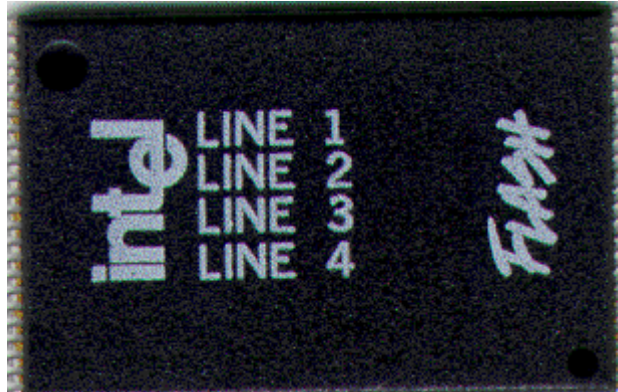

**New Mark:**

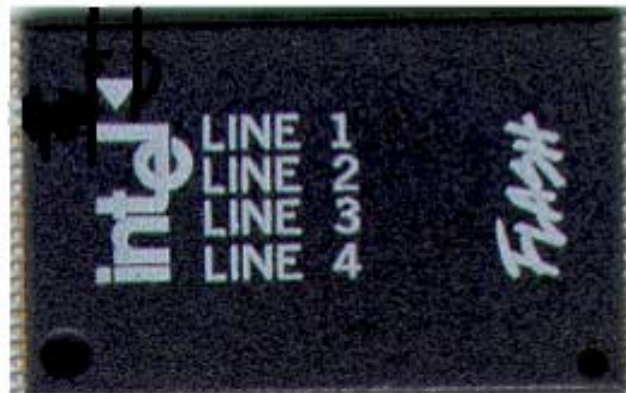

**Note:** The topside marking on 8 Mb, 16 Mb, and 32 Mb Advanced & Advanced + Boot Block 40L and 48L TSOP products will convert to a white ink triangle as a Pin-1 indicator. Products without the white triangle will continue to use a dimple as a Pin-1 indicator. There are no other changes in package size, materials, functionality, customer handling, or manufacturability. Product will continue to meet stringent Intel quality requirements.

Products Affected are Intel Ordering Codes:



Ordering Information Valid Combinations

	40-Lead TSOP	48-Lead TSOP
Ext. Temp. 32 Mbit		TE28F320B3TC70 TE28F320B3BC70 TE28F320B3TC90 TE28F320B3BC90 TE28F320B3TA100 TE28F320B3BA100 TE28F320B3TA110 TE28F320B3BA110
Ext. Temp. 16 Mbit	TE28F016B3TA90 <sup>(3)</sup> TE28F016B3BA90 <sup>(3)</sup> TE28F016B3TA110 <sup>(3)</sup> TE28F016B3BA110 <sup>(3)</sup>	TE28F160B3TC70 TE28F160B3BC70 TE28F160B3TC80 TE28F160B3BC80 TE28F160B3TA90 <sup>(3)</sup> TE28F160B3BA90 <sup>(3)</sup> TE28F160B3TA110 <sup>(3)</sup> TE28F160B3BA110 <sup>(3)</sup>
Ext. Temp. 8 Mbit	TE28F008B3TA90 <sup>(3)</sup> TE28F008B3BA90 <sup>(3)</sup> TE28F008B3TA110 <sup>(3)</sup> TE28F008B3BA110 <sup>(3)</sup>	TE28F800B3TA90 <sup>(3)</sup> TE28F800B3BA90 <sup>(3)</sup> TE28F800B3TA110 <sup>(3)</sup> TE28F800B3BA110 <sup>(3)</sup>

Figure 4. x8 48-Ball  $\mu$ BGA\* Chip Size Package (Top View, Ball Down)

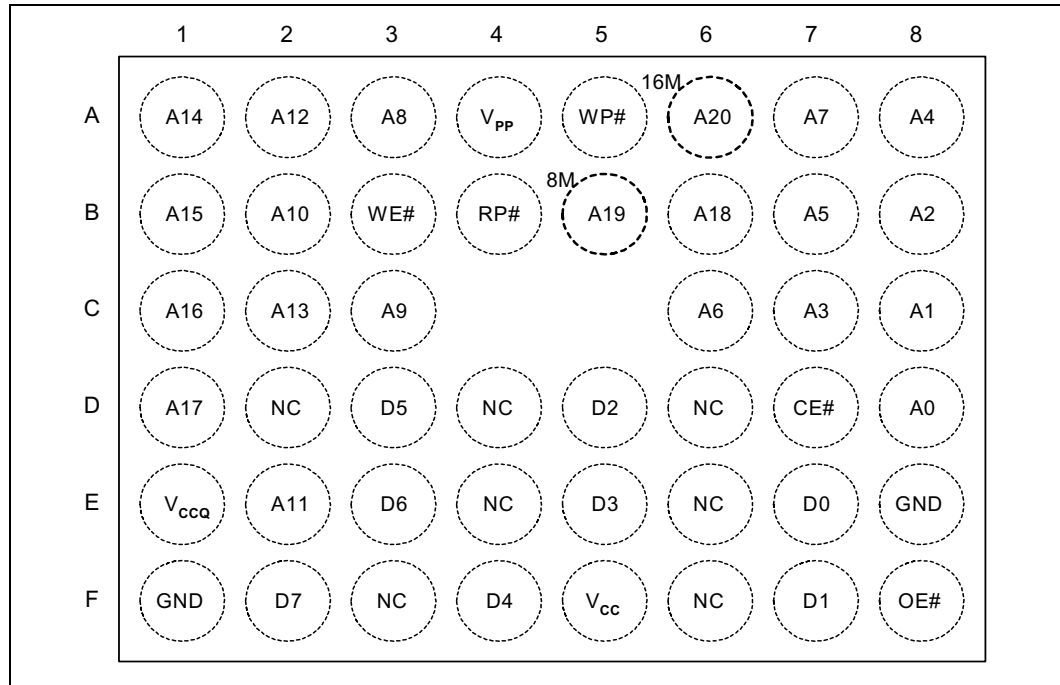

0580\_04

**NOTES:**

1. Shaded connections indicate the upgrade address connections. Lower density devices will not have the upper address solder balls. Routing is not recommended in this area. A<sub>20</sub> is the upgrade address for the 16-Mbit device.

Figure 5. x16 48-Ball Very Fine Pitch BGA and  $\mu$ BGA\* Chip Size Package (Top View, Ball Down)

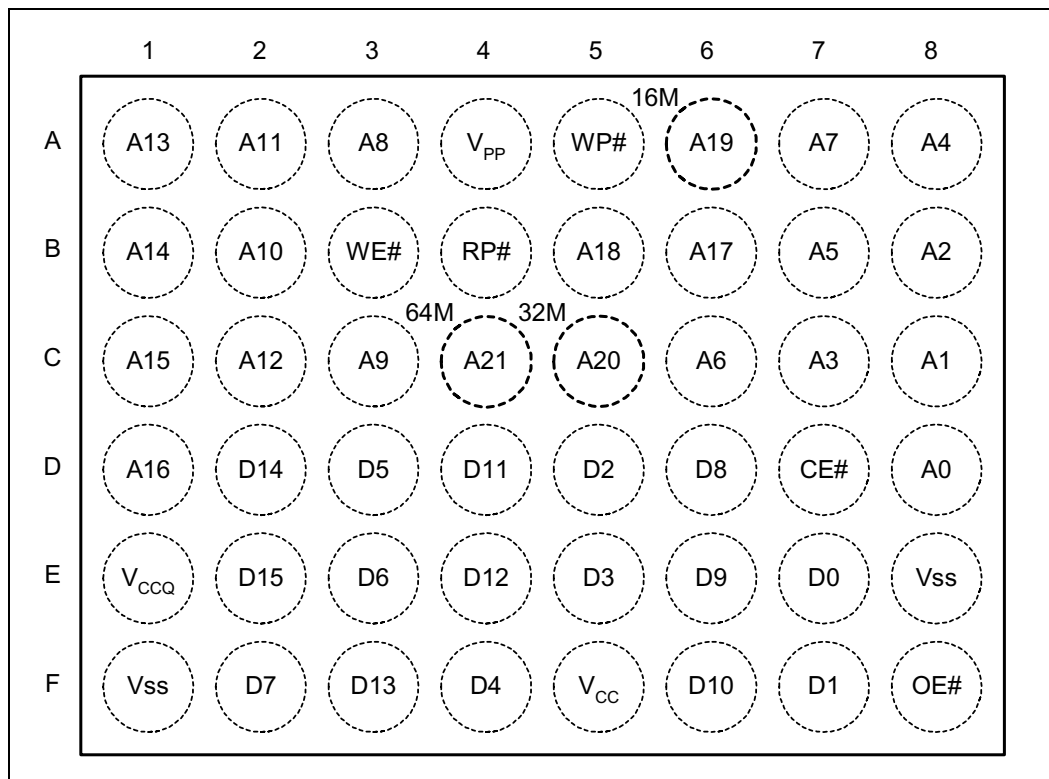

0580\_03

**NOTES:**

1. Shaded connections indicate the upgrade address connections. Lower density devices will not have the upper address solder balls. Routing is not recommended in this area. A<sub>19</sub> is the upgrade address for the 16-Mbit device. A<sub>20</sub> is the upgrade address for the 32-Mbit device. A<sub>21</sub> is the upgrade address for the 64-Mbit device.
2. Table 2, "3-Volt Advanced Boot Block Pin Descriptions" on page 9 details the usage of each device pin.

**Table 2. 3-Volt Advanced Boot Block Pin Descriptions**

Symbol	Type	Name and Function
A <sub>0</sub> –A <sub>21</sub>	INPUT	<b>ADDRESS INPUTS</b> for memory addresses. Addresses are internally latched during a program or erase cycle. 28F008B3: A[0-19], 28F016B3: A[0-20], 28F800B3: A[0-18], 28F160B3: A[0-19], 28F320B3: A[0-20], 28F640B3: A[0-21]
DQ <sub>0</sub> –DQ <sub>7</sub>	INPUT/ OUTPUT	<b>DATA INPUTS/OUTPUTS:</b> Inputs array data on the second CE# and WE# cycle during a Program command. Inputs commands to the Command User Interface when CE# and WE# are active. Data is internally latched. Outputs array, identifier and status register data. The data pins float to tri-state when the chip is de-selected or the outputs are disabled.
DQ <sub>8</sub> – DQ <sub>15</sub>	INPUT/ OUTPUT	<b>DATA INPUTS/OUTPUTS:</b> Inputs array data on the second CE# and WE# cycle during a Program command. Data is internally latched. Outputs array and identifier data. The data pins float to tri-state when the chip is de-selected. <b>Not included on x8 products.</b>
CE#	INPUT	<b>CHIP ENABLE:</b> Activates the internal control logic, input buffers, decoders and sense amplifiers. CE# is active low. CE# high de-selects the memory device and reduces power consumption to standby levels.
OE#	INPUT	<b>OUTPUT ENABLE:</b> Enables the device's outputs through the data buffers during a Read operation. OE# is active low.
WE#	INPUT	<b>WRITE ENABLE:</b> Controls writes to the Command Register and memory array. WE# is active low. Addresses and data are latched on the rising edge of the second WE# pulse.
RP#	INPUT	<b>RESET/DEEP POWER-DOWN:</b> Uses two voltage levels ( $V_{IL}$ , $V_{IH}$ ) to control reset/deep power-down mode. <b>When RP# is at logic low, the device is in reset/deep power-down mode</b> , which drives the outputs to High-Z, resets the Write State Machine, and minimizes current levels ( $I_{CCD}$ ). <b>When RP# is at logic high, the device is in standard operation.</b> When RP# transitions from logic-low to logic-high, the device defaults to the read array mode.
WP#	INPUT	<b>WRITE PROTECT:</b> Provides a method for locking and unlocking the two lockable parameter blocks. <b>When WP# is at logic low, the lockable blocks are locked</b> , preventing Program and Erase operations to those blocks. If a Program or Erase operation is attempted on a locked block, SR.1 and either SR.4 [program] or SR.5 [erase] will be set to indicate the operation failed. <b>When WP# is at logic high, the lockable blocks are unlocked</b> and can be programmed or erased. See <a href="#">Section 3.3</a> for details on write protection.
V <sub>CCQ</sub>	INPUT	<b>OUTPUT V<sub>CC</sub>:</b> Enables all outputs to be driven to 1.8 V – 2.5 V while the V <sub>CC</sub> is at 2.7 V–3.3 V. If the V <sub>CC</sub> is regulated to 2.7 V–2.85 V, V <sub>CCQ</sub> can be driven at 1.65 V–2.5 V to achieve lowest power operation (see <a href="#">Section 4.4</a> ). This input may be tied directly to V <sub>CC</sub> (2.7 V–3.6 V).
V <sub>CC</sub>		<b>DEVICE POWER SUPPLY:</b> 2.7 V–3.6 V
V <sub>PP</sub>		<b>PROGRAM/ERASE POWER SUPPLY:</b> Supplies power for Program and Erase operations. V <sub>PP</sub> may be the same as V <sub>CC</sub> (2.7 V–3.6 V) for single supply voltage operation. For fast programming at manufacturing, 11.4 V–12.6 V may be supplied to V <sub>PP</sub> . This pin cannot be left floating. Applying 11.4 V–12.6 V to V <sub>PP</sub> can only be done for a maximum of 1000 cycles on the main blocks and 2500 cycles on the parameter blocks. V <sub>PP</sub> may be connected to 12 V for a total of 80 hours maximum (see <a href="#">Section 3.4</a> for details). V <sub>PP</sub> < V <sub>PPLK</sub> protects memory contents against inadvertent or unintended program and erase commands.
GND		<b>GROUND:</b> For all internal circuitry. All ground inputs <b>must</b> be connected.
NC		<b>NO CONNECT:</b> Pin may be driven or left floating.

## 2.2 Block Organization

The 3-Volt Advanced Boot Block is an asymmetrically blocked architecture that enables system integration of code and data within a single flash device. Each block can be erased independently of the others up to 100,000 times. For the address locations of each block, see the memory maps in [Appendix C](#).

### 2.2.1 Parameter Blocks

The 3-Volt Advanced Boot Block flash memory architecture includes parameter blocks to facilitate storage of frequently updated small parameters (i.e., data that would normally be stored in an EEPROM). The word-rewrite functionality of EEPROMs can be emulated using software techniques. Each device contains eight parameter blocks of 8 Kbytes/4 Kwords (8192 bytes/4,096 words) each.

### 2.2.2 Main Blocks

After the parameter blocks, the remainder of the array is divided into equal-size main blocks (65,536 bytes/32,768 words) for data or code storage. The 8-Mbit device contains 15 main blocks; 16-Mbit flash has 31 main blocks; 32-Mbit has 63 main blocks; 64-Mbit has 127 main blocks.

## 3.0 Principles of Operation

Flash memory combines EEPROM functionality with in-circuit electrical program-and-erase capability. The 3-Volt Advanced Boot Block Flash Memory family utilizes a Command User Interface (CUI) and automated algorithms to simplify Program and Erase operations. The CUI allows for 100% CMOS-level control inputs and fixed power supplies during erasure and programming.

When  $V_{PP} < V_{PPLK}$ , the device will execute only the following commands successfully: Read Array, Read Status Register, Clear Status Register, and Read Identifier. The device provides standard EEPROM read, standby, and Output-Disable operations. Manufacturer identification and device identification data can be accessed through the CUI. All functions associated with altering memory contents, namely program and erase, are accessible via the CUI. The internal Write State Machine (WSM) completely automates Program and Erase operations, while the CUI signals the start of an operation and the status register reports status. The CUI handles the WE# interface to the data and address latches, as well as system status requests during WSM operation.

### 3.1 Bus Operation

3-Volt Advanced Boot Block flash memory devices read, program, and erase in-system via the local CPU or microcontroller. All bus cycles to or from the flash memory conform to standard microcontroller bus cycles. Four control pins dictate the data flow in and out of the flash component: CE#, OE#, WE#, and RP#. [Table 3](#) summarizes these bus operations.

**Table 3. Bus Operations<sup>(1)</sup>**

Mode	Note	RP#	CE#	OE#	WE#	DQ <sub>0-7</sub>	DQ <sub>8-15</sub>
Read (Array, Status, or Identifier)	2-4	V <sub>IH</sub>	V <sub>IL</sub>	V <sub>IL</sub>	V <sub>IH</sub>	D <sub>OUT</sub>	D <sub>OUT</sub>
Output Disable	2	V <sub>IH</sub>	V <sub>IL</sub>	V <sub>IH</sub>	V <sub>IH</sub>	High Z	High Z
Standby	2	V <sub>IH</sub>	V <sub>IH</sub>	X	X	High Z	High Z
Reset	2, 7	V <sub>IL</sub>	X	X	X	High Z	High Z
Write	2, 5-7	V <sub>IH</sub>	V <sub>IL</sub>	V <sub>IH</sub>	V <sub>IL</sub>	D <sub>IN</sub>	D <sub>IN</sub>

**NOTES:**

1. 8-bit devices use only DQ[0:7], 16-bit devices use DQ[0:15].
2. X must be V<sub>IL</sub>, V<sub>IH</sub> for control pins and addresses.
3. See *DC Characteristics* for V<sub>PPLK</sub>, V<sub>PP1</sub>, V<sub>PP2</sub>, V<sub>PP3</sub>, V<sub>PP4</sub> voltages.
4. Manufacturer and device codes may also be accessed in read identifier mode (A<sub>1</sub>-A<sub>21</sub> = 0). See [Table 5](#).
5. Refer to [Table 6](#) for valid D<sub>IN</sub> during a Write operation.
6. To program or erase the lockable blocks, hold WP# at V<sub>IH</sub>.
7. RP# must be at GND ± 0.2 V to meet the maximum deep power-down current specified.

### 3.1.1 Read

The flash memory has four read modes available: read array, read identifier, read status, and read query. These modes are accessible independent of the V<sub>PP</sub> voltage. The appropriate Read Mode command must be issued to the CUI to enter the corresponding mode. Upon initial device power-up or after exit from reset, the device automatically defaults to read-array mode.

CE# and OE# must be driven active to obtain data at the outputs. CE# is the device selection control; when active, it enables the flash memory device. OE# is the data output control, and it drives the selected memory data onto the I/O bus. For all read modes, WE# and RP# must be at V<sub>IH</sub>. [Figure 8](#) illustrates a read cycle.

### 3.1.2 Output Disable

With OE# at a logic-high level (V<sub>IH</sub>), the device outputs are disabled. Output pins are placed in a high-impedance state.

### 3.1.3 Standby

Deselecting the device by bringing CE# to a logic-high level (V<sub>IH</sub>) places the device in standby mode, which substantially reduces device power consumption without any latency for subsequent read accesses. In standby, outputs are placed in a high-impedance state independent of OE#. If deselected during Program or Erase operation, the device continues to consume active power until the Program or Erase operation is complete.

### 3.1.4 Deep Power-Down / Reset

From read mode, RP# at V<sub>IL</sub> for time t<sub>PLPH</sub> deselects the memory, places output drivers in a high-impedance state, and turns off all internal circuits. After return from reset, a time t<sub>PHQV</sub> is required until the initial read-access outputs are valid. A delay (t<sub>PHWL</sub> or t<sub>PHL</sub>) is required after return from reset before a write can be initiated. After this wake-up interval, normal operation is restored. The CUI resets to read-array mode, and the status register is set to 80H. [Figure 10A](#) illustrates this case.

If RP# is taken low for time  $t_{PLRH}$  during a Program or Erase operation, the operation will be aborted and the memory contents at the aborted location (for a program) or block (for an erase) are no longer valid, since the data may be partially erased or written. The abort process goes through the following sequence:

1. When RP# goes low, the device shuts down the operation in progress, a process that takes time  $t_{PLRH}$  to complete.
2. After this time  $t_{PLRH}$ , the part will either reset to read-array mode (if RP# has gone high during  $t_{PLRH}$ , [Figure 10B](#)), or enter reset mode (if RP# is still logic low after  $t_{PLRH}$ , [Figure 10C](#)).
3. In both cases, after returning from an aborted operation, the relevant time  $t_{PHQV}$  or  $t_{PHWL}/t_{PHEL}$  must be waited before a Read or Write operation is initiated, as discussed in the previous paragraph. However, in this case, these delays are referenced to the end of  $t_{PLRH}$  rather than when RP# goes high.

As with any automated device, it is important to assert RP# during system reset. When the system comes out of reset, the processor expects to read from the flash memory. Automated flash memories provide status information when read during program or Block-Erase operations. If a CPU reset occurs with no flash memory reset, proper CPU initialization may not occur because the flash memory may be providing status information instead of array data. Intel® Flash memories allow proper CPU initialization following a system reset through the use of the RP# input. In this application, RP# is controlled by the same RESET# signal that resets the system CPU.

### 3.1.5 Write

A write occurs when both CE# and WE# are low and OE# is high. Commands are written to the Command User Interface (CUI) using standard microprocessor write timings to control Flash operations. The CUI does not occupy an addressable memory location. The address and data buses are latched on the rising edge of the second WE# or CE# pulse, whichever occurs first. [Figure 9](#) illustrates a Program and Erase operation. [Table 6](#) shows the available commands, and [Appendix A](#) provides detailed information on moving between the different modes of operation using CUI commands.

Two commands modify array data: Program (40H), and Erase (20H). Writing either of these commands to the internal Command User Interface (CUI) initiates a sequence of internally timed functions that culminate in the completion of the requested task (unless that operation is aborted by either RP# being driven to  $V_{IL}$  for  $t_{PLRH}$  or an appropriate Suspend command).

## 3.2 Modes of Operation

The flash memory has four read modes (read array, read identifier, read status, and read query; see [Appendix B](#)), and two write modes (program and block erase). Three additional modes (erase suspend to program, erase suspend to read, and program suspend to read) are available only during suspended operations. [Table 4](#) summarizes the commands used to reach these modes. [Appendix A](#) is a comprehensive chart showing the state transitions.

### 3.2.1 Read Array

When RP# transitions from  $V_{IL}$  (reset) to  $V_{IH}$ , the device defaults to read-array mode and will respond to the read-control inputs (CE#, address inputs, and OE#) without any additional CUI commands.

When the device is in read-array mode, four control signals control data output.

- WE# must be logic high ( $V_{IH}$ )
- CE# must be logic low ( $V_{IL}$ )
- OE# must be logic low ( $V_{IL}$ )
- RP# must be logic high ( $V_{IH}$ )

In addition, the address of the preferred location must be applied to the address pins. If the device is not in read-array mode, as would be the case after a Program or Erase operation, the Read Array command (FFH) must be written to the CUI before array reads can occur.

**Table 4. Command Codes and Descriptions**

Code	Device Mode	Description
00, 01, 60, 2F, C0, 98	Invalid/Reserved	Unassigned commands that should not be used. Intel reserves the right to redefine these codes for future functions.
FF	Read Array	Places the device in read-array mode, such that array data will be output on the data pins.
40	Program Set-Up	This is a two-cycle command. The first cycle prepares the CUI for a program operation. The second cycle latches addresses and data information and initiates the WSM to execute the program algorithm. The flash outputs status register data when CE# or OE# is toggled. A Read Array command is required after programming to read array data. See <a href="#">Section 3.2.4</a> .
10	Alternate Program Set-Up	(See 40H/Program Set-Up)
20	Erase Set-Up	Prepares the CUI for the Erase Confirm command. If the next command is not an Erase Confirm command, then the CUI will (a) set both SR.4 and SR.5 of the status register to a "1," (b) place the device into the read-status-register mode, and (c) wait for another command. See <a href="#">Section 3.2.5</a> .
D0	Erase Confirm Program / Erase Resume	If the previous command was an Erase Set-Up command, then the CUI will close the address and data latches, and begin erasing the block indicated on the address pins. During erase, the device will only respond to the Read Status Register and Erase Suspend commands. The device will output status-register data when CE# or OE# is toggled. If a Program or Erase operation was previously suspended, this command will resume that operation.
B0	Program / Erase Suspend	Issuing this command will begin to suspend the currently executing Program/Erase operation. The status register will indicate when the operation has been successfully suspended by setting either the program suspend (SR.2) or erase suspend (SR.6), and the WSM status bit (SR.7) to a "1" (ready). The WSM will continue to idle in the SUSPEND state, regardless of the state of all input-control pins except RP#, which will immediately shut down the WSM and the remainder of the chip, if it is driven to $V_{IL}$ . See <a href="#">Section 3.2.4.1</a> and <a href="#">Section 3.2.4.1</a> .
70	Read Status Register	This command places the device into read-status-register mode. Reading the device will output the contents of the status register, regardless of the address presented to the device. The device automatically enters this mode after a Program or Erase operation has been initiated. See <a href="#">Section 3.2.3</a> .
50	Clear Status Register	The WSM can set the block-lock status (SR.1), $V_{PP}$ status (SR.3), program status (SR.4), and erase status (SR.5) bits in the status register to "1," but it cannot clear them to "0." Issuing this command clears those bits to "0."
90	Read Identifier	Puts the device into the intelligent-identifier-read mode, so that reading the device will output the manufacturer and device codes ( $A_0 = 0$ for manufacturer, $A_0 = 1$ for device, all other address inputs must be 0). See <a href="#">Section 3.2.2</a> .

**NOTE:** See [Appendix A](#) for mode transition information.

### 3.2.2 Read Identifier

To read the manufacturer and device codes, the device must be in read-identifier mode, which can be reached by writing the Read Identifier command (90H). Once in read-identifier mode,  $A_0 = 0$  outputs the manufacturer's identification code, and  $A_0 = 1$  outputs the device identifier (see Table 5) Note:  $A_1-A_{21} = 0$ . To return to read-array mode, write the Read-Array command (FFH).

**Table 5. Read Identifier Table**

Size	Mfr. ID	Device Identifier	
		-T (Top Boot)	-B (Bottom Boot)
28F004B3	0089H	D4H	D5H
28F400B3		8894H	8895H
28F008B3	0089H	D2H	D3H
28F800B3		8892H	8893H
28F016B3		D0H	D1H
28F160B3	0089H	8890H	8891H
28F320B3		8896H	8897H
28F640B3		8898H	8899H

### 3.2.3 Read Status Register

The device status register indicates when a Program or Erase operation is complete, and the success or failure of that operation. To read the status register, issue the Read Status Register (70H) command to the CUI. This causes all subsequent Read operations to output data from the status register until another command is written to the CUI. To return to reading from the array, issue the Read Array (FFH) command.

The status-register bits are output on  $DQ_0-DQ_7$ . The upper byte,  $DQ_8-DQ_{15}$ , outputs 00H during a Read Status Register command.

The contents of the status register are latched on the falling edge of  $OE\#$  or  $CE\#$ , which prevents possible Bus errors that might occur if status-register contents change while being read.  $CE\#$  or  $OE\#$  must be toggled with each subsequent status read, or the status register will not indicate completion of a Program or Erase operation.

When the WSM is active, SR.7 will indicate the status of the WSM; the remaining bits in the status register indicate whether or not the WSM was successful in performing the preferred operation (see Table 7 on page 17).

#### 3.2.3.1 Clearing the Status Register

The WSM sets status bits 1 through 7 to "1," and clears bits 2, 6, and 7 to "0," but cannot clear status bits 1 or 3 through 5 to "0." Because bits 1, 3, 4, and 5 indicate various error conditions, these bits can be cleared only through the Clear Status Register (50H) command. By allowing the system software to control the resetting of these bits, several operations may be performed (such as cumulatively programming several addresses or erasing multiple blocks in sequence) before

reading the status register to determine if an error occurred during that series. Clear the status register before beginning another command or sequence. Note, again, that the Read Array command must be issued before data can be read from the memory array.

### 3.2.4 Program Mode

Programming is executed using a two-write sequence. The Program Setup command (40H) is written to the CUI followed by a second write that specifies the address and data to be programmed. The WSM will execute a sequence of internally timed events to program preferred bits of the addressed location, then verify the bits are sufficiently programmed. Programming the memory results in specific bits within an address location being changed to a “0.” If users attempt to program “1”s, the memory cell contents do not change and no error occurs.

The status register indicates programming status: while the program sequence executes, status bit 7 is “0.” The status register can be polled by toggling either CE# or OE#. While programming, the only valid commands are Read Status Register, Program Suspend, and Program Resume.

When programming is complete, the program-status bits should be checked. If the programming operation was unsuccessful, bit SR.4 of the status register is set to indicate a program failure. If SR.3 is set, then  $V_{PP}$  was not within acceptable limits, and the WSM did not execute the program command. If SR.1 is set, a program operation was attempted on a locked block and the operation was aborted.

The status register should be cleared before attempting the next operation. Any CUI instruction can follow after programming is completed; however, to prevent inadvertent status-register reads, be sure to reset the CUI to read-array mode.

#### 3.2.4.1 Suspending and Resuming Program

The Program Suspend halts the in-progress program operation to read data from another location of memory. Once the programming process starts, writing the Program Suspend command to the CUI requests that the WSM suspend the program sequence (at predetermined points in the program algorithm). The device continues to output status-register data after the Program Suspend command is written. Polling status-register bits SR.7 and SR.2 will determine when the program operation has been suspended (both will be set to “1”).  $t_{WHRH1}/t_{EHRH1}$  specify the program-suspend latency.

A Read Array command can now be written to the CUI to read data from blocks other than that which is suspended. The only other valid commands while program is suspended are Read Status Register, Read Identifier, and Program Resume. After the Program Resume command is written to the flash memory, the WSM will continue with the program process and status-register bits SR.2 and SR.7 will automatically be cleared. After the Program Resume command is written, the device automatically outputs status-register data when read (see [Appendix E](#) for *Program Suspend and Resume Flowchart*).  $V_{PP}$  must remain at the same  $V_{PP}$  level used for program while in program-suspend mode. RP# must also remain at  $V_{IH}$ .

### 3.2.5 Erase Mode

To erase a block, write the Erase Set-up and Erase Confirm commands to the CUI, along with an address identifying the block to be erased. This address is latched internally when the Erase Confirm command is issued. Block erasure results in all bits within the block being set to “1.” Only one block can be erased at a time. The WSM will execute a sequence of internally timed events to program all bits within the block to “0,” erase all bits within the block to “1,” then verify that all bits within the block are sufficiently erased. While the erase executes, status bit 7 is a “0.”

When the status register indicates that erasure is complete, check the erase-status bit to verify that the Erase operation was successful. If the Erase operation was unsuccessful, SR.5 of the status register will be set to a “1,” indicating an erase failure. If  $V_{PP}$  was not within acceptable limits after the Erase Confirm command was issued, the WSM will not execute the erase sequence; instead, SR.5 of the status register is set to indicate an Erase error, and SR.3 is set to a “1” to identify that  $V_{PP}$  supply voltage was not within acceptable limits.

After an Erase operation, clear the status register (50H) before attempting the next operation. Any CUI instruction can follow after erasure is completed; however, to prevent inadvertent status-register reads, it is advisable to place the flash in read-array mode after the erase is complete.

### 3.2.5.1 Suspending and Resuming Erase

Since an Erase operation requires on the order of seconds to complete, an Erase Suspend command is provided to allow erase-sequence interruption in order to read data from—or program data to—another block in memory. Once the erase sequence is started, writing the Erase Suspend command to the CUI requests that the WSM pause the erase sequence at a predetermined point in the erase algorithm. The status register will indicate if/when the Erase operation has been suspended.

A Read Array/Program command can now be written to the CUI in order to read data from/program data to blocks other than the one currently suspended. The Program command can subsequently be suspended to read yet another array location. The only valid commands while Erase is suspended are Erase Resume, Program, Read Array, Read Status Register, or Read Identifier. During erase-suspend mode, the chip can be placed in a pseudo-standby mode by taking  $CE\#$  to  $V_{IH}$ , which reduces active current consumption.

Erase Resume continues the erase sequence when  $CE\# = V_{IL}$ . As with the end of a standard Erase operation, the status register must be read and cleared before the next instruction is issued.

**Table 6. Command Bus Definitions** (1,4)

Command	Notes	First Bus Cycle			Second Bus Cycle		
		Oper	Addr	Data	Oper	Addr	Data
Read Array		Write	X	FFH			
Read Identifier	2	Write	X	90H	Read	IA	ID
Read Status Register		Write	X	70H	Read	X	SRD
Clear Status Register		Write	X	50H			
Program	3	Write	X	40H / 10H	Write	PA	PD
Block Erase/Confirm		Write	X	20H	Write	BA	D0H
Program/Erase Suspend		Write	X	B0H			
Program/Erase Resume		Write	X	D0H			

**NOTES:**

**PA:** Program Address    **PD:** Program Data    **BA:** Block Address  
**IA:** Identifier Address    **ID:** Identifier Data    **SRD:** Status Register Data

- Bus operations are defined in [Table 3](#).
- Following the Intelligent Identifier command, two Read operations access manufacturer and device codes.  $A_0 = 0$  for manufacturer code,  $A_0 = 1$  for device code.  $A_1-A_{21} = 0$ .
- Either 40H or 10H command is valid although the standard is 40H.
- When writing commands to the device, the upper data bus [ $DQ_8-DQ_{15}$ ] should be either  $V_{IL}$  or  $V_{IH}$ , to minimize current draw.

**Table 7. Status Register Bit Definition**

WSMS	ESS	ES	PS	VPPS	PSS	BLS	R
7	6	5	4	3	2	1	0
				<b>NOTES:</b>			
SR.7 = WRITE STATE MACHINE STATUS (WSMS) 1 = Ready 0 = Busy				Check Write State Machine bit first to determine word program or block-erase completion, before checking program or erase-status bits.			
SR.6 = ERASE-SUSPEND STATUS (ESS) 1 = Erase Suspended 0 = Erase In Progress/Completed				When erase suspend is issued, WSM halts execution and sets both WSMS and ESS bits to "1." ESS bit remains set at "1" until an Erase Resume command is issued.			
SR.5 = ERASE STATUS (ES) 1 = Error In Block Erasure 0 = Successful Block Erase				When this bit is set to "1," WSM has applied the max. number of erase pulses to the block and is still unable to verify successful block erasure.			
SR.4 = PROGRAM STATUS (PS) 1 = Error in Word Program 0 = Successful Word Program				When this bit is set to "1," WSM has attempted but failed to program a word.			
SR.3 = V <sub>PP</sub> STATUS (VPPS) 1 = V <sub>PP</sub> Low Detect, Operation Abort 0 = V <sub>PP</sub> OK				The V <sub>PP</sub> status bit does not provide continuous indication of V <sub>PP</sub> level. The WSM interrogates V <sub>PP</sub> level only after the Program or Erase command sequences have been entered, and informs the system if V <sub>PP</sub> has not been switched on. The V <sub>PP</sub> is also checked before the operation is verified by the WSM. The V <sub>PP</sub> status bit is not guaranteed to report accurate feedback between V <sub>PPLK</sub> max and V <sub>PP1</sub> min or between V <sub>PP1</sub> max and V <sub>PP4</sub> min.			
SR.2 = PROGRAM SUSPEND STATUS (PSS) 1 = Program Suspended 0 = Program in Progress/Completed				When program suspend is issued, WSM halts execution and sets both WSMS and PSS bits to "1." PSS bit remains set to "1" until a Program Resume command is issued.			
SR.1 = BLOCK LOCK STATUS 1 = Program/Eraser attempted on locked block; Operation aborted 0 = No operation to locked blocks				If a Program or Erase operation is attempted to one of the locked blocks, this bit is set by the WSM. The operation specified is aborted and the device is returned to read status mode.			
SR.0 = RESERVED FOR FUTURE ENHANCEMENTS (R)				This bit is reserved for future use and should be masked out when polling the status register.			

**NOTE:** A Command Sequence Error is indicated when SR.4, SR.5, and SR.7 are set.

## 3.3 Block Locking

The 3-Volt Advanced Boot Block flash memory architecture features two hardware-lockable parameter blocks.

### 3.3.1 WP# = V<sub>IL</sub> for Block Locking

The lockable blocks are locked when WP# = V<sub>IL</sub>; any program or Erase operation to a locked block will result in an error, which will be reflected in the status register. For top configuration, the top two parameter blocks (blocks #133 and #134 for the 64 Mbit, #69 and #70 for the 32 Mbit, blocks #37 and #38 for the 16 Mbit, blocks #21 and #22 for the 8 Mbit, blocks #13 and #14 for the 4 Mbit) are lockable. For the bottom configuration, the bottom two parameter blocks (blocks #0 and #1 for 4 /8 /16 /32/64 Mbit) are lockable. Unlocked blocks can be programmed or erased normally (unless V<sub>PP</sub> is below V<sub>PPLK</sub>).

### 3.3.2 WP# = V<sub>IH</sub> for Block Unlocking

WP# = V<sub>IH</sub> unlocks all lockable blocks.

These blocks can now be programmed or erased.

Note that RP# does not override WP# locking as in previous Boot Block devices. WP# controls all block locking and V<sub>PP</sub> provides protection against spurious writes. Table 8 defines the write-protection methods.

**Table 8. Write-Protection Truth Table for the Advanced Boot Block Flash Memory Family**

V <sub>PP</sub>	WP#	RP#	Write Protection Provided
X	X	V <sub>IL</sub>	All Blocks Locked
V <sub>IL</sub>	X	V <sub>IH</sub>	All Blocks Locked
≥ V <sub>PPLK</sub>	V <sub>IL</sub>	V <sub>IH</sub>	Lockable Blocks Locked
≥ V <sub>PPLK</sub>	V <sub>IH</sub>	V <sub>IH</sub>	All Blocks Unlocked

## 3.4 V<sub>PP</sub> Program and Erase Voltages

Intel® 3-Volt Advanced Boot Block products provide in-system programming and erase at 2.7 V. For customers requiring fast programming in their manufacturing environment, 3-Volt Advanced Boot Block includes an additional low-cost 12-V programming feature.

The 12-V V<sub>PP</sub> mode enhances programming performance during the short period of time typically found in manufacturing processes; however, it is not intended for extended use. 12 V may be applied to V<sub>PP</sub> during program and Erase operations for a maximum of 1000 cycles on the main blocks, and 2500 cycles on the parameter blocks. V<sub>PP</sub> may be connected to 12 V for a total of 80 hours maximum.

**Warning:** Stressing the device beyond these limits may cause permanent damage.

During Read operations or idle times, V<sub>PP</sub> may be tied to a 5-V supply. For Program and Erase operations, a 5-V supply is not permitted. The V<sub>PP</sub> must be supplied with either 2.7 V–3.6 V or 11.4 V–12.6 V during Program and Erase operations.

### 3.4.1 V<sub>PP</sub> = V<sub>IL</sub> for Complete Protection

The V<sub>PP</sub> programming voltage can be held low for complete write protection of all blocks in the flash device. When V<sub>PP</sub> is below V<sub>PPLK</sub>, any Program or Erase operation will result in an error, prompting the corresponding status-register bit (SR.3) to be set.

## 3.5 Power Consumption

Intel flash devices have a tiered approach to power savings that can significantly reduce overall system power consumption. The Automatic Power Savings (APS) feature reduces power consumption when the device is selected but idle. If the CE# is deasserted, the flash enters its standby mode, where current consumption is even lower. The combination of these features can minimize memory power consumption, and therefore, overall system power consumption.

### 3.5.1 Active Power

With CE# at a logic-low level and RP# at a logic-high level, the device is in the active mode. Refer to the DC Characteristic tables for  $I_{CC}$  current values. Active power is the largest contributor to overall system power consumption. Minimizing the active current could have a profound effect on system power consumption, especially for battery-operated devices.

### 3.5.2 Automatic Power Savings (APS)

Automatic Power Savings provides low-power operation during read mode. After data is read from the memory array and the address lines are quiescent, APS circuitry places the device in a mode where typical current is comparable to  $I_{CCS}$ . The flash stays in this static state with outputs valid until a new location is read.

### 3.5.3 Standby Power

With CE# at a logic-high level ( $V_{IH}$ ) and the device in read mode, the flash memory is in standby mode, which disables much of the device circuitry, and substantially reduces power consumption. Outputs are placed in a high-impedance state independent of the status of the OE# signal. If CE# transitions to a logic-high level during Erase or Program operations, the device will continue to perform the operation and consume corresponding active power until the operation is completed.

System engineers should analyze the breakdown of standby time versus active time, and quantify the respective power consumption in each mode for their specific application. This approach will provide a more accurate measure of application-specific power and energy requirements.

### 3.5.4 Deep Power-Down Mode

The deep power-down mode is activated when  $RP\# = V_{IL}$  ( $GND \pm 0.2 V$ ). During read modes, RP# going low de-selects the memory and places the outputs in a high-impedance state. Recovery from deep power-down requires a minimum time of  $t_{PHQV}$  (see *AC Characteristics—Read Operations*, Section 4.5).

During program or erase modes, RP# transitioning low will abort the in-progress operation. The memory contents of the address being programmed or the block being erased are no longer valid as the data integrity has been compromised by the abort. During deep power-down, all internal circuits are switched to a low-power savings mode (RP# transitioning to  $V_{IL}$  or turning off power to the device clears the status register).

## 3.6 Power and Reset Considerations

### 3.6.1 Power-Up/Down Characteristics

In order to prevent any condition that may result in a spurious write or erase operation, it is recommended to power-up  $V_{CC}$  and  $V_{CCQ}$  together. Conversely,  $V_{CC}$  and  $V_{CCQ}$  must power-down together. It is also recommended to power-up  $V_{PP}$  with or slightly after  $V_{CC}$ . Conversely,  $V_{PP}$  must powerdown with or slightly before  $V_{CC}$ .

If  $V_{CCQ}$  and/or  $V_{PP}$  are not connected to the  $V_{CC}$  supply, then  $V_{CC}$  should attain  $V_{CCMin}$  before applying  $V_{CCQ}$  and  $V_{PP}$ . Device inputs should not be driven before supply voltage =  $V_{CCMin}$ . Power supply transitions should only occur when RP# is low.

### 3.6.2 RP# Connected to System Reset

The use of RP# during system reset is important with automated program/erase devices because the system expects to read from the flash memory when it exits reset. If a CPU reset occurs without a flash memory reset, proper CPU initialization will not occur because the flash memory may be providing status information instead of array data. Intel recommends connecting RP# to the system CPU RESET# signal to allow proper CPU/flash initialization following system reset.

System designers must guard against spurious writes when  $V_{CC}$  voltages are above  $V_{LKO}$ . Because both WE# and CE# must be low for a command write, driving either signal to  $V_{IH}$  will inhibit writes to the device. The CUI architecture provides additional protection since alteration of memory contents can occur only after successful completion of the two-step command sequences. The device is also disabled until RP# is brought to  $V_{IH}$ , regardless of the state of its control inputs. By holding the device in reset (RP# connected to system POWERGOOD) during power-up/down, invalid bus conditions during power-up can be masked, providing yet another level of memory protection.

### 3.6.3 $V_{CC}$ , $V_{PP}$ and RP# Transitions

The CUI latches commands as issued by system software and is not altered by  $V_{PP}$  or CE# transitions or WSM actions. Its default state upon power-up, after exit from reset mode or after  $V_{CC}$  transitions above  $V_{LKO}$  (Lockout voltage), is read-array mode.

After any program or Block-Erase operation is complete (even after  $V_{PP}$  transitions down to  $V_{PPLK}$ ), the CUI must be reset to read-array mode via the Read Array command if access to the flash-memory array is required.

## 3.7 Power Supply Decoupling

Flash memory power-switching characteristics require careful device decoupling. System designers should consider the following three supply current issues:

1. Standby current levels ( $I_{CCS}$ )
2. Read current levels ( $I_{CCR}$ )
3. Transient peaks produced by falling and rising edges of CE#.

Transient current magnitudes depend on the device outputs' capacitive and inductive loading. Two-line control and proper decoupling capacitor selection will suppress these transient voltage peaks. Each flash device should have a 0.1  $\mu$ F ceramic capacitor connected between each  $V_{CC}$  and GND, and between its  $V_{PP}$  and GND. These high-frequency, inherently low-inductance capacitors should be placed as close as possible to the package leads.

## 4.0 Electrical Specifications

### 4.1 Absolute Maximum Ratings

Parameter	Maximum Rating
Extended Operating Temperature	-40 °C to +85 °C
During Read	
During Block Erase and Program	
Temperature under Bias	-40 °C to +85 °C
Storage Temperature	-65 °C to +125 °C
Voltage On Any Pin (except V <sub>CC</sub> , V <sub>CCQ</sub> and V <sub>PP</sub> ) with Respect to GND	-0.5 V to +3.7 V <sup>(1)</sup>
V <sub>PP</sub> Voltage (for Block Erase and Program) with Respect to GND	-0.5 V to +13.5 V <sup>(1,2,3)</sup>
V <sub>CC</sub> and V <sub>CCQ</sub> Supply Voltage with Respect to GND	-0.2 V to +3.7 V <sup>(4)</sup>
Output Short Circuit Current	100 mA <sup>(5)</sup>

**NOTES:**

1. Minimum DC voltage is -0.5 V on input/output pins, with allowable undershoot to -2.0 V for periods <20 ns. Maximum DC voltage on input/output pins is V<sub>CC</sub> +0.5 V, with allowable overshoot to V<sub>CC</sub> +1.5 for periods of <20 ns
2. Maximum DC voltage on V<sub>PP</sub> may overshoot to +14.0 V for periods <20 ns.
3. V<sub>PP</sub> Program voltage is normally 2.7 V–3.6 V. Connection to a 11.4 V–12.6 V supply can be done for a maximum of 1000 cycles on the main blocks and 2500 cycles on the parameter blocks during program/erase. V<sub>PP</sub> may be connected to 12 V for a total of 80 hours maximum. See [Section 3.4](#) for details.
4. Minimum DC voltage is -0.5 V on V<sub>CC</sub> and V<sub>CCQ</sub>, with allowable undershoot to -2.0 V for periods <20 ns. Maximum DC voltage on V<sub>CC</sub> and V<sub>CCQ</sub> pins is V<sub>CC</sub> +0.5 V, with allowable overshoot to V<sub>CC</sub> +1.5 for periods of <20 ns.
5. Output shorted for no more than one second. No more than one output shorted at a time.

**NOTICE:** This datasheet contains preliminary information on new products in production. Specifications are subject to change without notice. Verify with your local Intel Sales office that you have the latest datasheet before finalizing a design.

**Warning:** Stressing the device beyond the “Absolute Maximum Ratings” may cause permanent damage. These are stress ratings only. Operation beyond the “Operating Conditions” is not recommended and extended exposure beyond the “Operating Conditions” may affect device reliability.

## 4.2 Operating Conditions

Symbol	Parameter	Notes	Min	Max	Units
$T_A$	Operating Temperature		-40	+85	°C
$V_{CC1}$	$V_{CC}$ Supply Voltage	1, 2	2.7	3.6	Volts
$V_{CC2}$			2.7	2.85	
$V_{CC3}$			2.7	3.3	
$V_{CCQ1}$	I/O Supply Voltage	1	2.7	3.6	Volts
$V_{CCQ2}$			1.65	2.5	
$V_{CCQ3}$			1.8	2.5	
$V_{PP1}$	Program and Erase Voltage	1	2.7	3.6	Volts
$V_{PP2}$			2.7	2.85	
$V_{PP3}$			2.7	3.3	
$V_{PP4}$		3, 4	11.4	12.6	
Cycling	Block Erase Cycling	4	100,000		Cycles

### NOTES:

- $V_{CC1}$ ,  $V_{CCQ1}$ , and  $V_{PP3}$  must share the same supply when all three are between 2.7 V and 3.6 V.
- $V_{CCMax}$  is 3.3 V on 0.25 $\mu$ m 32-Mbit devices.
- During Read operations or idle time, 5 V may be applied to  $V_{PP}$  indefinitely.  $V_{PP}$  must be at valid levels for Program and Erase operations
- Applying  $V_{PP} = 11.4$  V–12.6 V during a program/erase can only be done for a maximum of 1000 cycles on the main blocks and 2500 cycles on the parameter blocks.  $V_{PP}$  may be connected to 12 V for a total of 80 hours maximum. See [Section 3.4](#) for details.

## 4.3 Capacitance

$T_A = 25$  °C,  $f = 1$  MHz

Sym	Parameter	Notes	Typ	Max	Units	Conditions
$C_{IN}$	Input Capacitance	1	6	8	pF	$V_{IN} = 0$ V
$C_{OUT}$	Output Capacitance	1	10	12	pF	$V_{OUT} = 0$ V

**NOTE:** Sampled, not 100% tested.

## 4.4 DC Characteristics

Sym	Parameter	V <sub>CC</sub>	2.7 V–3.6 V		2.7 V–2.85 V		2.7 V–3.3 V		Unit	Test Conditions
		V <sub>CCQ</sub>	2.7 V–3.6 V		1.65 V–2.5 V		1.8 V–2.5 V			
		Note	Typ	Max	Typ	Max	Typ	Max		
I <sub>LI</sub>	Input Load Current	1,2		± 1		± 1		± 1	μA	V <sub>CC</sub> = V <sub>CC</sub> Max V <sub>CCQ</sub> = V <sub>CCQ</sub> Max V <sub>IN</sub> = V <sub>CCQ</sub> or GND
I <sub>LO</sub>	Output Leakage Current	1,2	0.2	± 10	0.2	± 10	0.2	± 10	μA	V <sub>CC</sub> = V <sub>CC</sub> Max V <sub>CCQ</sub> = V <sub>CCQ</sub> Max V <sub>IN</sub> = V <sub>CCQ</sub> or GND
I <sub>CCS</sub>	V <sub>CC</sub> Standby Current for 0.13 and 0.18 Micron Product	1	7	15	20	50	150	250	μA	V <sub>CC</sub> = V <sub>CC</sub> Max CE# = RP# = V <sub>CCQ</sub> or during Program/ Erase Suspend
	V <sub>CC</sub> Standby Current for 0.25 Micron Product	1	18	35	20	50	150	250	μA	WP# = V <sub>CCQ</sub> or GND
I <sub>CCD</sub>	V <sub>CC</sub> Power-Down Current for 0.13 and 0.18 Micron Product	1,2	7	15	7	20	7	20	μA	V <sub>CC</sub> = V <sub>CC</sub> Max V <sub>CCQ</sub> = V <sub>CCQ</sub> Max V <sub>IN</sub> = V <sub>CCQ</sub> or GND
	V <sub>CC</sub> Power-Down Current for 0.25 Product	1,2	7	25	7	25	7	25	μA	RP# = GND ± 0.2 V
I <sub>CCR</sub>	V <sub>CC</sub> Read Current for 0.13 and 0.18 Micron Product	1,2,3	9	18	8	15	9	15	mA	V <sub>CC</sub> = V <sub>CC</sub> Max V <sub>CCQ</sub> = V <sub>CCQ</sub> Max OE# = V <sub>IH</sub> , CE# = V <sub>IL</sub> f = 5 MHz, I <sub>OUT</sub> = 0 mA Inputs = V <sub>IL</sub> or V <sub>IH</sub>
	V <sub>CC</sub> Read Current for 0.25 Micron Product	1,2,3	10	18	8	15	9	15	mA	
I <sub>PPD</sub>	V <sub>PP</sub> Deep Power-Down Current	1	0.2	5	0.2	5	0.2	5	μA	RP# = GND ± 0.2 V V <sub>PP</sub> ≤ V <sub>CC</sub>
I <sub>CCW</sub>	V <sub>CC</sub> Program Current for 0.13 and 0.18 Micron Product	1,4	18	55	18	55	18	55	mA	V <sub>PP</sub> = V <sub>PP1,2,3</sub> Program in Progress
			8	15	10	30	10	30	mA	V <sub>PP</sub> = V <sub>PP4</sub> (12v), Program in Progress
	V <sub>CC</sub> Program Current for 0.25 Micron Product	1,4	18	55	18	55	18	55	mA	V <sub>PP</sub> = V <sub>PP1,2,3</sub> Program in Progress
			10	30	10	30	10	30	mA	V <sub>PP</sub> = V <sub>PP4</sub> (12v), Program in Progress
I <sub>CCE</sub>	V <sub>CC</sub> Erase Current	1,4	16	45	21	45	21	45	mA	V <sub>PP</sub> = V <sub>PP1,2,3</sub> Erase in Progress
			8	15	16	45	16	45	mA	V <sub>PP</sub> = V <sub>PP4</sub> (12v), Erase in Progress
I <sub>CCES</sub>	V <sub>CC</sub> Erase Suspend Current	1,4	7	15	50	200	150	250	μA	CE# = V <sub>CC</sub> , Erase Suspend in Progress
I <sub>PPR</sub>	V <sub>PP</sub> Read Current	1,4	2	±15	2	±15	2	±15	μA	V <sub>PP</sub> ≤ V <sub>CC</sub>
			50	200	50	200	50	200	μA	V <sub>PP</sub> > V <sub>CC</sub>
I <sub>PPW</sub>	V <sub>PP</sub> Program Current	1,4	0.05	0.1	0.05	0.1	0.05	0.1	mA	V <sub>PP</sub> = V <sub>PP1,2,3</sub> Program in Progress
			8	22	8	22	8	22	mA	V <sub>PP</sub> = V <sub>PP4</sub> (12v), Program in Progress

Sym	Parameter	V <sub>CC</sub>	2.7 V–3.6 V		2.7 V–2.85 V		2.7 V–3.3 V		Unit	Test Conditions
		V <sub>CCQ</sub>	2.7 V–3.6 V		1.65 V–2.5 V		1.8 V–2.5 V			
		Note	Typ	Max	Typ	Max	Typ	Max		
I <sub>PPPE</sub>	V <sub>PP</sub> Erase Current	1,4	0.05	0.1	0.05	0.1	0.05	0.1	mA	V <sub>PP</sub> = V <sub>PP1,2,3</sub> Erase in Progress
			8	22	16	45	16	45	mA	V <sub>PP</sub> = V <sub>PP4 (12V)</sub> , Erase in Progress
I <sub>PPES</sub>	V <sub>CC</sub> Erase Suspend Current	1,4	0.2	5	0.2	5	0.2	5	μA	V <sub>PP</sub> = V <sub>PP1,2,3</sub> Program or Erase Suspend in Progress
			50	200	50	200	50	200	μA	V <sub>PP</sub> = V <sub>PP4 (12V)</sub> , Program or Erase Suspend in Progress
I <sub>PPWS</sub>	V <sub>PP</sub> Program Suspend Current	1,4	0.2	5	0.2	5	0.2	5	μA	V <sub>PP</sub> = V <sub>PP1,2,3</sub> Program or Erase Suspend in Progress
			50	200	50	200	50	200	μA	V <sub>PP</sub> = V <sub>PP4 (12V)</sub> , Program or Erase Suspend in Progress



**NOTE:** AC test inputs are driven at  $V_{CCQ}$  for a logic "1" and 0.0V for a logic "0." Input timing begins, and output timing ends, at  $V_{CCQ}/2$ . Input rise and fall times (10%–90%) <10 ns. Worst-case speed conditions are when  $V_{CCQ} = V_{CCQMin}$ .

**Figure 7. Test Configuration**

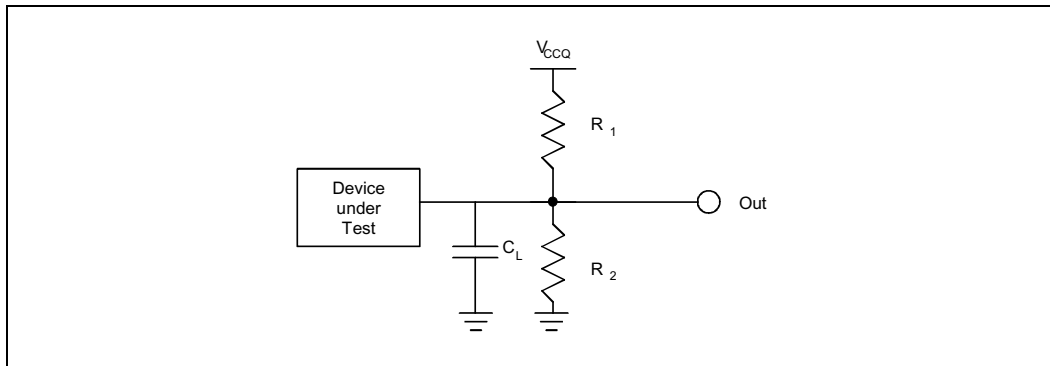

**NOTE:** See table for component values.

0580\_06

Test Configuration Component Values for Worst Case Speed Conditions			
Test Configuration	$C_L$ (pF)	$R_1$ ( $\Omega$ )	$R_2$ ( $\Omega$ )
$V_{CCQ1}$ Standard Test	50	25 K	25 K
$V_{CCQ2}$ Standard Test	50	14.5 K	14.5 K
$V_{CCQ3}$ Standard Test	50	16 K	16 K

**NOTE:**  $C_L$  includes jig capacitance.

## 4.5 AC Characteristics —Read Operations

#	Sym	Parameter	Density	8 Mbit								Unit
			Product	90 ns				110 ns				
			V <sub>CC</sub>	3.0 V–3.6 V		2.7 V–3.6 V		3.0 V–3.6 V		2.7 V–3.6 V		
				Min	Max	Min	Max	Min	Max	Min	Max	
R1	t <sub>AVAV</sub>	Read Cycle Time		80		90		100		110		ns
R2	t <sub>AVQV</sub>	Address to Output Delay			80		90		100		110	ns
R3	t <sub>ELQV</sub>	CE# to Output Delay <sup>(1)</sup>			80		90		100		110	ns
R4	t <sub>GLQV</sub>	OE# to Output Delay <sup>(1)</sup>			30		30		30		30	ns
R5	t <sub>PHQV</sub>	RP# to Output Delay			600		600		600		600	ns
R6	t <sub>ELQX</sub>	CE# to Output in Low Z <sup>(2)</sup>		0		0		0		0		ns
R7	t <sub>GLQX</sub>	OE# to Output in Low Z <sup>(2)</sup>		0		0		0		0		ns
R8	t <sub>EHQZ</sub>	CE# to Output in High Z <sup>(2)</sup>			25		25		25		25	ns
R9	t <sub>GHQZ</sub>	OE# to Output in High Z <sup>(2)</sup>			25		25		25		25	ns
R10	t <sub>OH</sub>	Output Hold from Address, CE#, or OE# Change, Whichever Occurs First <sup>(2)</sup>		0		0		0		0		ns

**NOTES:**

1. OE# may be delayed up to t<sub>ELQV</sub>–t<sub>GLQV</sub> after the falling edge of CE# without impact on t<sub>ELQV</sub>.
2. Sampled, but not 100% tested.

See Figure 8, “AC Waveform: Read Operations” on page 31.

See Figure 6, “Input/Output Reference Waveform” on page 25 for timing measurements and maximum allowable input slew rate.

## AC Characteristics, Continued

#	Sym	Parameter	Density	16 Mbit												Unit
			Product	70 ns		80 ns		90 ns				110 ns				
			V <sub>CC</sub>	2.7 V–3.6 V		2.7 V–3.6 V		3.0 V–3.6 V		2.7 V–3.6 V		3.0 V–3.6 V		2.7 V–3.6 V		
				Min	Max	Min	Max	Min	Max	Min	Max	Min	Max	Min	Max	
R1	t <sub>AVAV</sub>	Read Cycle Time		70		80		80		90		100		110		ns
R2	t <sub>AVQV</sub>	Address to Output Delay			70		80		80		90		100		110	ns
R3	t <sub>ELQV</sub>	CE# to Output Delay <sup>(1)</sup>			70		80		80		90		100		110	ns
R4	t <sub>GLQV</sub>	OE# to Output Delay <sup>(1)</sup>			20		20		30		30		30		30	ns
R5	t <sub>PHQV</sub>	RP# to Output Delay			150		150		600		600		600		600	ns
R6	t <sub>ELQX</sub>	CE# to Output in Low Z <sup>(2)</sup>		0		0		0		0		0		0		ns
R7	t <sub>GLQX</sub>	OE# to Output in Low Z <sup>(2)</sup>		0		0		0		0		0		0		ns
R8	t <sub>EHQZ</sub>	CE# to Output in High Z <sup>(2)</sup>			20		20		25		25		25		25	ns
R9	t <sub>GHQZ</sub>	OE# to Output in High Z <sup>(2)</sup>			20		20		25		25		25		25	ns
R10	t <sub>OH</sub>	Output Hold from Address, CE#, or OE# Change, Whichever Occurs First <sup>(2)</sup>		0		0		0		0		0		0		ns

## NOTES:

1. OE# may be delayed up to t<sub>ELQV</sub>-t<sub>GLQV</sub> after the falling edge of CE# without impact on t<sub>ELQV</sub>.
2. Sampled, but not 100% tested.

See Figure 8, "AC Waveform: Read Operations" on page 31.

See Figure 6, "Input/Output Reference Waveform" on page 25 for timing measurements and maximum allowable input slew rate.

## AC Characteristics, Continued

#	Sym	Parameter	Density	32 Mbit												Unit
			Product	70 ns		90 ns		100 ns				110 ns				
			V <sub>CC</sub>	2.7 V–3.6 V		2.7 V–3.6 V		3.0 V–3.3 V		2.7 V–3.3 V		3.0 V–3.3 V		2.7 V–3.3 V		
				Min	Max	Min	Max	Min	Max	Min	Max	Min	Max	Min	Max	
R1	t <sub>AVAV</sub>	Read Cycle Time	70		90		90		100		100		110		ns	
R2	t <sub>AVQV</sub>	Address to Output Delay		70		90		90		100		100		110	ns	
R3	t <sub>ELQV</sub>	CE# to Output Delay <sup>(1)</sup>		70		90		90		100		100		110	ns	
R4	t <sub>GLQV</sub>	OE# to Output Delay <sup>(1)</sup>		20		20		30		30		30		30	ns	
R5	t <sub>PHQV</sub>	RP# to Output Delay		150		150		600		600		600		600	ns	
R6	t <sub>ELQX</sub>	CE# to Output in Low Z <sup>(2)</sup>	0		0		0		0		0		0		ns	
R7	t <sub>GLQX</sub>	OE# to Output in Low Z <sup>(2)</sup>	0		0		0		0		0		0		ns	
R8	t <sub>EHQZ</sub>	CE# to Output in High Z <sup>(2)</sup>		20		20		25		25		25		25	ns	
R9	t <sub>GHQZ</sub>	OE# to Output in High Z <sup>(2)</sup>		20		20		25		25		25		25	ns	
R10	t <sub>OH</sub>	Output Hold from Address, CE#, or OE# Change, Whichever Occurs First <sup>(2)</sup>	0		0		0		0		0		0		ns	

**NOTES:**

1. OE# may be delayed up to t<sub>ELQV</sub>–t<sub>GLQV</sub> after the falling edge of CE# without impact on t<sub>ELQV</sub>.
2. Sampled, but not 100% tested.

See Figure 8, “AC Waveform: Read Operations” on page 31.

See Figure 6, “Input/Output Reference Waveform” on page 25 for timing measurements and maximum allowable input slew rate.

## AC Characteristics, Continued

#	Sym	Parameter	Density	64 Mbit		Unit	
			Product	80 ns			
			V <sub>CC</sub>	2.7 V–3.6 V			
			Note	Min	Max		
R1	t <sub>AVAV</sub>	Read Cycle Time			80		ns
R2	t <sub>AVQV</sub>	Address to Output Delay				80	ns
R3	t <sub>ELQV</sub>	CE# to Output Delay	1			80	ns
R4	t <sub>GLQV</sub>	OE# to Output Delay	1			20	ns
R5	t <sub>PHQV</sub>	RP# to Output Delay				150	ns
R6	t <sub>ELQX</sub>	CE# to Output in Low Z	2		0		ns
R7	t <sub>GLQX</sub>	OE# to Output in Low Z	2		0		ns
R8	t <sub>EHQZ</sub>	CE# to Output in High Z	2			20	ns
R9	t <sub>GHQZ</sub>	OE# to Output in High Z	2			20	ns
R10	t <sub>OH</sub>	Output Hold from Address, CE#, or OE# Change, Whichever Occurs First	2		0		ns

**NOTES:**

1. OE# may be delayed up to t<sub>ELQV</sub>–t<sub>GLQV</sub> after the falling edge of CE# without impact on t<sub>ELQV</sub>.
2. Sampled, but not 100% tested.

See [Figure 8](#) for the AC waveform for Read operations.

See [Figure 6](#), "Input/Output Reference Waveform" on [page 25](#) for timing measurements and maximum allowable input slew rate.

Figure 8. AC Waveform: Read Operations

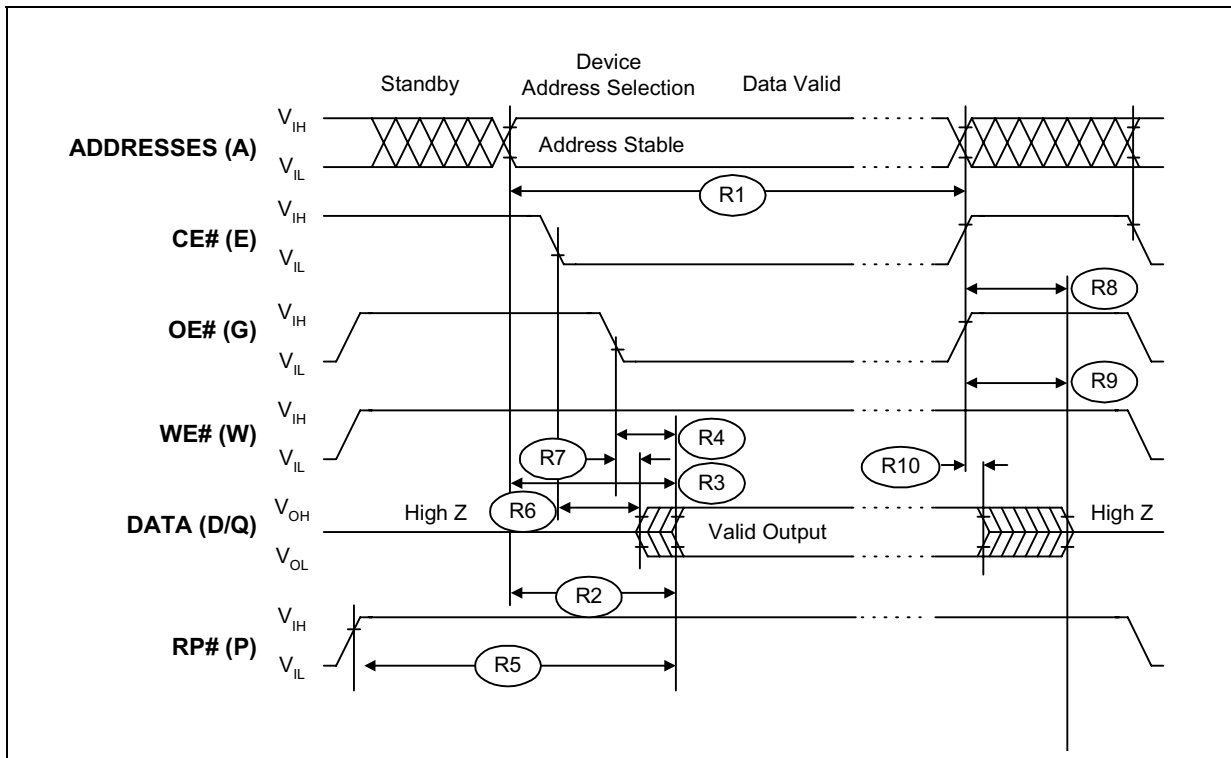

## 4.6 AC Characteristics —Write Operations

#	Sym	Parameter	Density	8 Mbit				Unit
			Product	90 ns		110 ns		
			V <sub>CC</sub>	3.0 V – 3.6 V	2.7 V – 3.6 V	3.0 V – 3.6 V	2.7 V – 3.6 V	
			Note	Min	Min	Min	Min	
W1	$t_{PHWL} / t_{PEHL}$	RP# High Recovery to WE# (CE#) Going Low		600	600	600	600	ns
W2	$t_{ELWL} / t_{WLEL}$	CE# (WE#) Setup to WE# (CE#) Going Low		0	0	0	0	ns
W3	$t_{ELEH} / t_{WLWH}$	WE# (CE#) Pulse Width	1	70	70	70	70	ns
W4	$t_{DVWH} / t_{DVEH}$	Data Setup to WE# (CE#) Going High	2	50	50	60	60	ns
W5	$t_{AVWH} / t_{AVEH}$	Address Setup to WE# (CE#) Going High	2	70	70	70	70	ns
W6	$t_{WHEH} / t_{EHWH}$	CE# (WE#) Hold Time from WE# (CE#) High		0	0	0	0	ns
W7	$t_{WHDX} / t_{EHDX}$	Data Hold Time from WE# (CE#) High	2	0	0	0	0	ns
W8	$t_{WHAX} / t_{EHAX}$	Address Hold Time from WE# (CE#) High	2	0	0	0	0	ns
W9	$t_{WHWL} / t_{EHEL}$	WE# (CE#) Pulse Width High	1	30	30	30	30	ns
W10	$t_{VPWH} / t_{VPEH}$	V <sub>PP</sub> Setup to WE# (CE#) Going High	3	200	200	200	200	ns
W11	$t_{QVVL}$	V <sub>PP</sub> Hold from Valid SRD	3	0	0	0	0	ns

### NOTES:

1. Refer to command definition table (Table 6) for valid A<sub>IN</sub> or D<sub>IN</sub>.
2. Write pulse width ( $t_{WP}$ ) is defined from CE# or WE# going low (whichever goes low last) to CE# or WE# going high (whichever goes high first). Hence,  $t_{WP} = t_{WLWH} = t_{ELEH} = t_{WLEH} = t_{ELWH}$ . Similarly, write pulse width high ( $t_{WPH}$ ) is defined from CE# or WE# going high (whichever goes high first) to CE# or WE# going low (whichever goes low first). Hence,  $t_{WPH} = t_{WHWL} = t_{EHEL} = t_{WHEL} = t_{EHWL}$ .
3. Sampled, but not 100% tested.

Read timing characteristics during program suspend and erase suspend are the same as during read-only operations.

See Figure 6 for timing measurements and maximum allowable input slew rate.

See Figure 9, “AC Waveform: Program and Erase Operations” on page 37.

**AC Characteristics—Write Operations, continued**

#	Sym	Parameter	Density	16 Mbit						Unit
			Product	70 ns	80 ns	90 ns		110 ns		
			V <sub>CC</sub>	2.7 V – 3.6 V	2.7 V – 3.6 V	3.0 V – 3.6 V	2.7 V – 3.6 V	3.0 V – 3.6 V	2.7 V – 3.6 V	
			Note	Min	Min	Min	Min	Min	Min	
W1	$t_{PHWL} / t_{PHEL}$	RP# High Recovery to WE# (CE#) Going Low		150	150	600	600	600	600	ns
W2	$t_{ELWL} / t_{WLEL}$	CE# (WE#) Setup to WE# (CE#) Going Low		0	0	0	0	0	0	ns
W3	$t_{ELEH} / t_{WLWH}$	WE# (CE#) Pulse Width	1	45	50	70	70	70	70	ns
W4	$t_{DVWH} / t_{DVEH}$	Data Setup to WE# (CE#) Going High	2	40	40	50	50	60	60	ns
W5	$t_{AVWH} / t_{AVEH}$	Address Setup to WE# (CE#) Going High	2	50	50	70	70	70	70	ns
W6	$t_{WHEH} / t_{EHHW}$	CE# (WE#) Hold Time from WE# (CE#) High		0	0	0	0	0	0	ns
W7	$t_{WHDX} / t_{EHDX}$	Data Hold Time from WE# (CE#) High	2	0	0	0	0	0	0	ns
W8	$t_{WHAX} / t_{EHAX}$	Address Hold Time from WE# (CE#) High	2	0	0	0	0	0	0	ns
W9	$t_{WHWL} / t_{EHEL}$	WE# (CE#) Pulse Width High	1	25	30	30	30	30	30	ns
W10	$t_{VPWH} / t_{VPEH}$	V <sub>PP</sub> Setup to WE# (CE#) Going High	3	200	200	200	200	200	200	ns
W11	$t_{QVVL}$	V <sub>PP</sub> Hold from Valid SRD	3	0	0	0	0	0	0	ns

**NOTES:**

1. Refer to command definition table (Table 6) for valid A<sub>IN</sub> or D<sub>IN</sub>.
2. Write pulse width ( $t_{WP}$ ) is defined from CE# or WE# going low (whichever goes low last) to CE# or WE# going high (whichever goes high first). Hence,  $t_{WP} = t_{WLWH} = t_{ELEH} = t_{WLEH} = t_{ELWH}$ . Similarly, write pulse width high ( $t_{WPH}$ ) is defined from CE# or WE# going high (whichever goes high first) to CE# or WE# going low (whichever goes low first). Hence,  $t_{WPH} = t_{WHWL} = t_{EHEL} = t_{WHEL} = t_{EHWL}$ .
3. Sampled, but not 100% tested.

Read timing characteristics during program suspend and erase suspend are the same as during Read-only operations.

See Figure 6 for timing measurements and maximum allowable input slew rate.

See Figure 9, "AC Waveform: Program and Erase Operations" on page 37.

## AC Characteristics—Write Operations, continued

#	Sym	Parameter	Density	32 Mbit						Unit
			Product	70 ns	90 ns	90 ns		110 ns		
			V <sub>CC</sub>	2.7 V – 3.6 V	2.7 V – 3.6 V	3.0 V – 3.3 V	2.7 V – 3.3 V	3.0 V – 3.3 V	2.7 V – 3.3 V	
			Note	Min	Min	Min	Min	Min	Min	
W1	t <sub>PHWL</sub> / t <sub>PHEL</sub>	RP# High Recovery to WE# (CE#) Going Low		150	150	600	600	600	600	ns
W2	t <sub>ELWL</sub> / t <sub>WLEL</sub>	CE# (WE#) Setup to WE# (CE#) Going Low		0	0	0	0	0	0	ns
W3	t <sub>ELEH</sub> / t <sub>WLWH</sub>	WE# (CE#) Pulse Width	1	45	60	70	70	70	70	ns
W4	t <sub>DVWH</sub> / t <sub>DVEH</sub>	Data Setup to WE# (CE#) Going High	2	40	40	50	50	60	60	ns
W5	t <sub>AVWH</sub> / t <sub>AVEH</sub>	Address Setup to WE# (CE#) Going High	2	50	60	70	70	70	70	ns
W6	t <sub>WHEH</sub> / t <sub>EHWH</sub>	CE# (WE#) Hold Time from WE# (CE#) High		0	0	0	0	0	0	ns
W7	t <sub>WHDX</sub> / t <sub>EHDX</sub>	Data Hold Time from WE# (CE#) High	2	0	0	0	0	0	0	ns
W8	t <sub>WHAX</sub> / t <sub>EHAX</sub>	Address Hold Time from WE# (CE#) High	2	0	0	0	0	0	0	ns
W9	t <sub>WHWL</sub> / t <sub>EHEL</sub>	WE# (CE#) Pulse Width High	1	25	30	30	30	30	30	ns
W10	t <sub>VPWH</sub> / t <sub>VPEH</sub>	V <sub>PP</sub> Setup to WE# (CE#) Going High	3	200	200	200	200	200	200	ns
W11	t <sub>QVVL</sub>	V <sub>PP</sub> Hold from Valid SRD	3	0	0	0	0	0	0	ns

**NOTES:**

1. Refer to command definition table (Table 6) for valid A<sub>IN</sub> or D<sub>IN</sub>.
2. Write pulse width (t<sub>WP</sub>) is defined from CE# or WE# going low (whichever goes low last) to CE# or WE# going high (whichever goes high first). Hence, t<sub>WP</sub> = t<sub>WLWH</sub> = t<sub>ELEH</sub> = t<sub>WLEH</sub> = t<sub>ELWH</sub>. Similarly, write pulse width high (t<sub>WPH</sub>) is defined from CE# or WE# going high (whichever goes high first) to CE# or WE# going low (whichever goes low first). Hence, t<sub>WPH</sub> = t<sub>WHWL</sub> = t<sub>EHEL</sub> = t<sub>WHEL</sub> = t<sub>EHWL</sub>.
3. Sampled, but not 100% tested.

Read timing characteristics during program suspend and erase suspend are the same as during read-only operations.

See Figure 6 for timing measurements and maximum allowable input slew rate.

See Figure 9, "AC Waveform: Program and Erase Operations" on page 37.

AC Characteristics—Write Operations, continued

#	Sym	Parameter	Density	64 Mbit	Unit
			Product	80 ns	
			V <sub>CC</sub>	2.7 V – 3.6 V	
			Note	Min	
W1	$t_{PHWL} / t_{PHEL}$	RP# High Recovery to WE# (CE#) Going Low		150	ns
W2	$t_{ELWL} / t_{WLEL}$	CE# (WE#) Setup to WE# (CE#) Going Low		0	ns
W3	$t_{ELEH} / t_{WLWH}$	WE# (CE#) Pulse Width	1	60	ns
W4	$t_{DVWH} / t_{DVEH}$	Data Setup to WE# (CE#) Going High	2	40	ns
W5	$t_{AVWH} / t_{AVEH}$	Address Setup to WE# (CE#) Going High	2	60	ns
W6	$t_{WHEH} / t_{EHWH}$	CE# (WE#) Hold Time from WE# (CE#) High		0	ns
W7	$t_{WHDX} / t_{EHDX}$	Data Hold Time from WE# (CE#) High	2	0	ns
W8	$t_{WHAX} / t_{EHAX}$	Address Hold Time from WE# (CE#) High	2	0	ns
W9	$t_{WHWL} / t_{EHEL}$	WE# (CE#) Pulse Width High	1	30	ns
W10	$t_{VPWH} / t_{VPEH}$	V <sub>PP</sub> Setup to WE# (CE#) Going High	3	200	ns
W11	$t_{QVVL}$	V <sub>PP</sub> Hold from Valid SRD	3	0	ns

NOTES:

1. Refer to command definition table (Table 6) for valid A<sub>IN</sub> or D<sub>IN</sub>.
2. Write pulse width ( $t_{WP}$ ) is defined from CE# or WE# going low (whichever goes low last) to CE# or WE# going high (whichever goes high first). Hence,  $t_{WP} = t_{WLWH} = t_{ELEH} = t_{WLEH} = t_{ELWH}$ . Similarly, write pulse width high ( $t_{WPH}$ ) is defined from CE# or WE# going high (whichever goes high first) to CE# or WE# going low (whichever goes low first). Hence,  $t_{WPH} = t_{WHWL} = t_{EHEL} = t_{WHEL} = t_{EHWL}$ .
3. Sampled, but not 100% tested.

Read timing characteristics during program suspend and erase suspend are the same as during read-only operations.

See Figure 6 for timing measurements and maximum allowable input slew rate.

See Figure 9, "AC Waveform: Program and Erase Operations" on page 37.

## 4.7 Program and Erase Timings

Symbol	Parameter	V <sub>PP</sub>	2.7 V–3.6 V		11.4 V–12.6 V		Units
		Notes	Typ <sup>(1)</sup>	Max	Typ <sup>(1)</sup>	Max	
t <sub>BWFPB</sub>	8-KB Parameter Block Program Time (Byte)	2, 3	0.16	0.48	0.08	0.24	s
	4-KW Parameter Block Program Time (Word)	2, 3	0.10	0.30	0.03	0.12	s
t <sub>BWMB</sub>	64-KB Main Block Program Time (Byte)	2, 3, 4	1.2	3.7	0.6	1.7	s
	32-KW Main Block Program Time (Word)	2, 3	0.8	2.4	0.24	1	s
t <sub>WHQV1</sub> / t <sub>EHQV1</sub>	Byte Program Time	2, 3, 4	17	165	8	185	μs
	Word Program Time for 0.13 and 0.18 Micron Product	2, 3	12	200	8	185	μs
	Word Program Time for 0.25 Micron Product	2, 3	22	200	8	185	μs
t <sub>WHQV2</sub> / t <sub>EHQV2</sub>	8-KB Parameter Block Erase Time (Byte)	2, 3, 4	1	4	0.8	4	s
	4-KW Parameter Block Erase Time (Word)	2, 3	0.5	4	0.4	4	s
t <sub>WHQV3</sub> / t <sub>EHQV3</sub>	64-KB Main Block Erase Time (Byte)	2, 3, 4	1	5	1	5	s
	32-KW Main Block Erase Time (Word)	2, 3	1	5	0.6	5	s
t <sub>WHRH1</sub> / t <sub>EHRH1</sub>	Program Suspend Latency		5	10	5	10	μs
t <sub>WHRH2</sub> / t <sub>EHRH2</sub>	Erase Suspend Latency		5	20	5	20	μs

### NOTES:

1. Typical values measured at nominal voltages and T<sub>A</sub> = +25 °C.
2. Excludes external system-level overhead.
3. Sampled, not 100% tested.
4. x8 not available on 0.13 and 0.18 μm offerings

Figure 9. AC Waveform: Program and Erase Operations

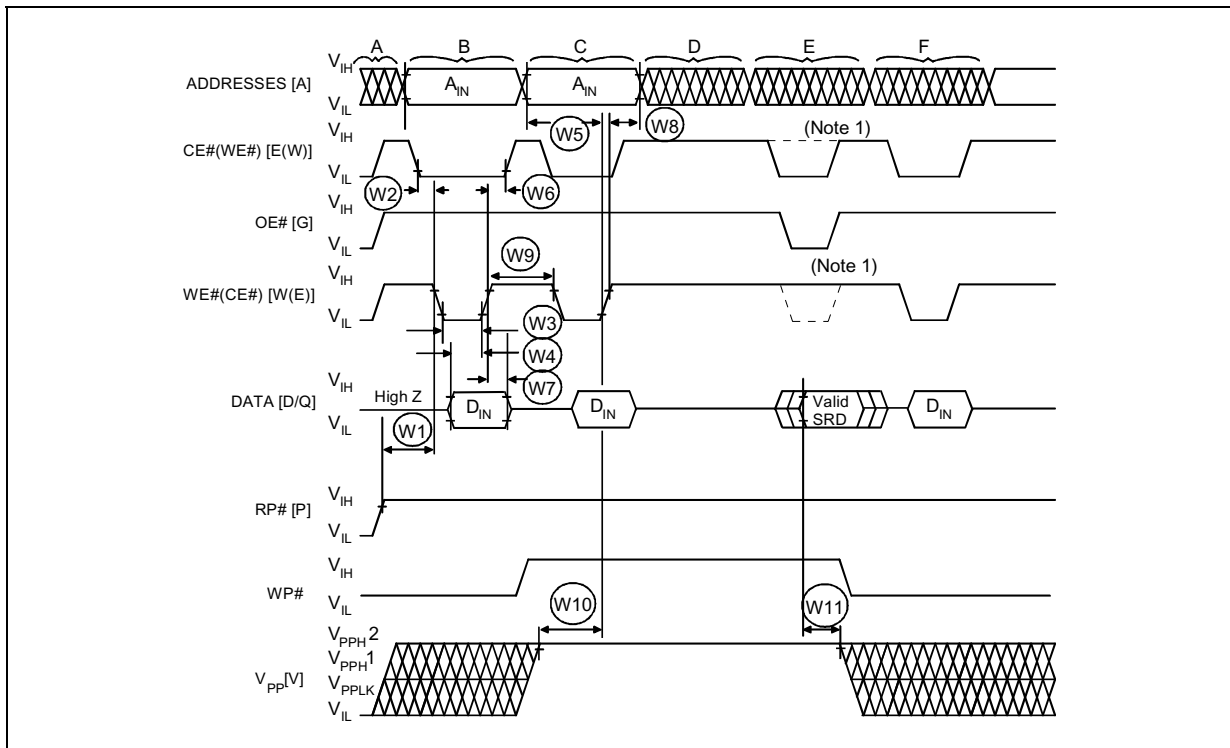

0580\_08

**NOTES:**

1. CE# must be toggled low when reading Status Register Data. WE# must be inactive (high) when reading Status Register Data.

- A. V<sub>CC</sub> Power-Up and Standby.
- B. Write Program or Erase Setup Command.
- C. Write Valid Address and Data (for Program) or Erase Confirm Command.
- D. Automated Program or Erase Delay.
- E. Read Status Register Data (SRD): reflects completed Program/Erase operation.
- F. Write Read Array Command.

## 5.0 Reset Operations

Figure 10. AC Waveform: Deep Power-Down/Reset Operation

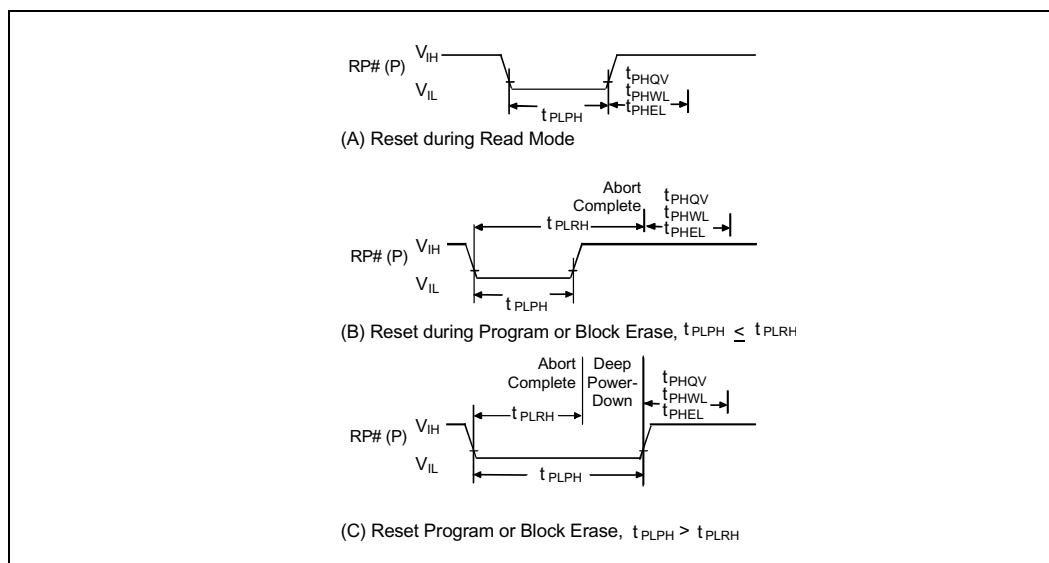

0580\_09

### Reset Specifications

Symbol	Parameter	Notes	V <sub>CC</sub> = 2.7 V–3.6 V		Unit
			Min	Max	
t <sub>PLPH</sub>	RP# Low to Reset during Read (If RP# is tied to V <sub>CC</sub> , this specification is not applicable)	1,2	100		ns
t <sub>PLRH</sub>	RP# Low to Reset during Block Erase or Program	2,3		22	μs

**NOTES:**

1. If t<sub>PLPH</sub> is <100 ns the device may still RESET but this is not guaranteed
2. .Sampled, but not 100% tested.
3. If RP# is asserted while a block erase or word program operation is not executing, the reset will complete within 100 ns.

## 6.0 Ordering Information

Figure 11. Ordering Information

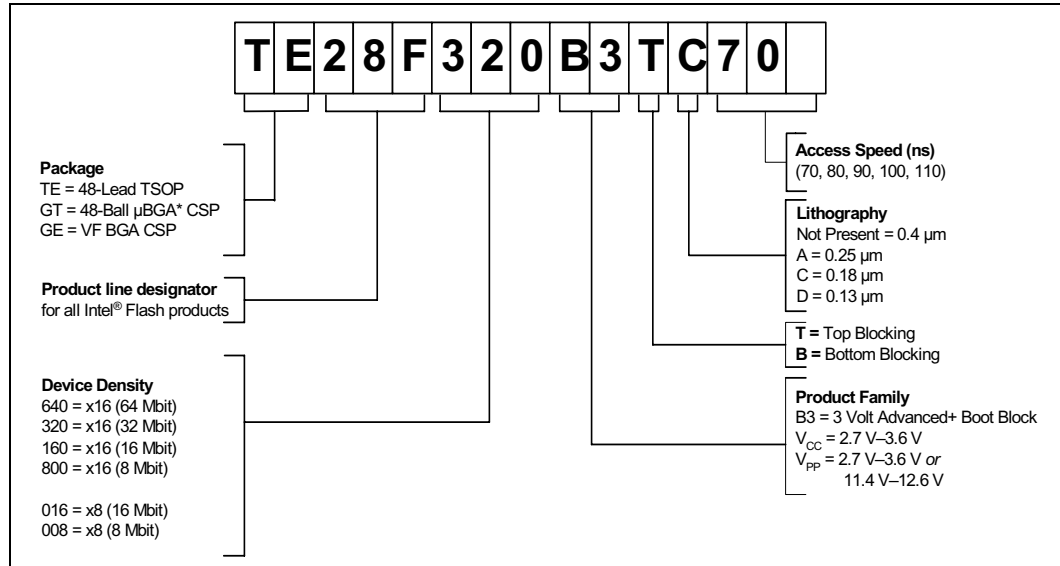

**Table 9. Ordering Information Valid Combinations**

	40-Lead TSOP	48-Lead TSOP	48-Ball $\mu$ BGA CSP <sup>(1,2)</sup>	48-Ball VF BGA
<b>Ext. Temp. 64 Mbit</b>		TE28F640B3TC80 TE28F640B3BC80		GE28F640B3TC80 GE28F640B3BC80
<b>Ext. Temp. 32 Mbit</b>		TE28F320B3TC70 TE28F320B3BC70 TE28F320B3TC90 TE28F320B3BC90 TE28F320B3TA100 TE28F320B3BA100 TE28F320B3TA110 TE28F320B3BA110		GE28F320B3TD70 GE28F320B3BD70 GE28F320B3TC70 GE28F320B3BC70 GE28F320B3TC90 GE28F320B3BC90
<b>Ext. Temp. 16 Mbit</b>	TE28F016B3TA90 TE28F016B3BA90 TE28F016B3TA110 TE28F016B3BA110	TE28F160B3TD70 TE28F160B3BD70 TE28F160B3TC70 TE28F160B3BC70 TE28F160B3TC80 TE28F160B3BC80 TE28F160B3TC90 TE28F160B3BC90 TE28F160B3TA90 TE28F160B3BA90 TE28F160B3TA110 TE28F160B3BA110	GT28F160B3TA90 <sup>(3)</sup> GT28F160B3BA90 <sup>(3)</sup> GT28F160B3TA110 <sup>(3)</sup> GT28F160B3BA110 <sup>(3)</sup>	GE28F160B3TD70 GE28F160B3BD70 GE28F160B3TC70 GE28F160B3BC70 GE28F160B3TC80 GE28F160B3BC80 GE28F160B3TC90 GE28F160B3BC90
<b>Ext. Temp. 8 Mbit</b>	TE28F008B3TA90 TE28F008B3BA90 TE28F008B3TA110 TE28F008B3BA110	TE28F800B3TA90 TE28F800B3BA90 TE28F800B3TA110 TE28F800B3BA110		GE28F800B3TA70 GE28F800B3BA70 GE28F008B3TA70 GE28F008B3BA70 GE28F800B3TA90 GE28F800B3BA90 GE28F008B3TA90 GE28F008B3BA90

1. The 48-ball  $\mu$ BGA package top side mark reads F160B3. This mark is identical for both x8 and x16 products. All product shipping boxes or trays provide the correct information regarding bus architecture. However, once the devices are removed from the shipping media, it may be difficult to differentiate based on the top side mark. The device identifier (accessible through the Device ID command: see [Section 3.2.2](#) for further details) enables x8 and x16  $\mu$ BGA package product differentiation.
2. The second line of the 48-ball  $\mu$ BGA package top side mark specifies assembly codes. For samples only, the first character signifies either "E" for engineering samples or "S" for silicon daisy-chain samples. All other assembly codes without an "E" or "S" as the first character are production units.
3. Intel recommends using .18  $\mu$ m Advanced Boot Block Products.



## 7.0 Additional Information

Order Number	Document/Tool
297948	<i>3 Volt Advanced Boot Block Flash Memory Family Specification Update</i>
292199	<i>AP-641 Achieving Low Power with the 3 Volt Advanced Boot Block Flash Memory</i>
292200	<i>AP-642 Designing for Upgrade to the 3 Volt Advanced Boot Block Flash Memory</i>
Note 2	<i>3 Volt Advanced Boot Block Algorithms ('C' and assembly)</i> <a href="http://developer.intel.com/design/flash/swtools">http://developer.intel.com/design/flash/swtools</a>
Contact your Intel Representative	<i>Intel® Flash Data Integrator (FDI) Software Developer's Kit</i>
297874	<i>FDI Interactive: Play with Intel® Flash Data Integrator on Your PC</i>

**NOTES:**

1. Please call the Intel Literature Center at (800) 548-4725 to request Intel documentation. International customers should contact their local Intel or distribution sales office.
2. Visit Intel's World Wide Web home page at <http://www.intel.com> or <http://developer.intel.com> for technical documentation and tools.
3. For the most current information on Intel Advanced and Advanced+ Boot Block Flash memory, visit our microsite at <http://developer.intel.com/design/flash/abblock>.



## Appendix A Write State Machine Current/Next States

Current State	SR.7	Data When Read	Command Input (and Next State)									
			Read Array (FFH)	Program Setup (10/40H)	Erase Setup (20H)	Erase Confirm (D0H)	Prog/Ers Suspend (B0H)	Prog/Ers Resume (D0H)	Read Status (70H)	Clear Status (50H)	Read Identifier (90H)	
Read Array	"1"	Array	Read Array	Program Setup	Erase Setup	Read Array			Read Status	Read Array	Read Identifier	
Read Status	"1"	Status	Read Array	Program Setup	Erase Setup	Read Array			Read Status	Read Array	Read Identifier	
Read Identifier	"1"	Identifier	Read Array	Program Setup	Erase Setup	Read Array			Read Status	Read Array	Read Identifier	
Prog. Setup	"1"	Status	Program (Command Input = Data to be Programmed)									
Program (continue)	"0"	Status	Program (continue)				Prog. Sysop. to Rd. Status	Program (continue)				
Program Suspend to Read Status	"1"	Status	Prog. Susp. to Read Array	Program Suspend to Read Array		Program (continue)	Program Suspend to Read Array	Program (continue)	Prog. Susp. to Read Status	Prog. Susp. to Read Array	Prog. Susp. to Read Identifier	
Program Suspend to Read Array	"1"	Array	Prog. Susp. to Read Array	Program Suspend to Read Array		Program (continue)	Program Suspend to Read Array	Program (continue)	Prog. Susp. to Read Status	Prog. Susp. to Read Array	Prog. Susp. to Read Identifier	
Prog. Susp. to Read Identifier	"1"	Identifier	Prog. Susp. to Read Array	Program Suspend to Read Array		Program (continue)	Program Suspend to Read Array	Program (continue)	Prog. Susp. to Read Status	Prog. Sus. to Read Array	Prog. Susp. to Read Identifier	
Program (complete)	"1"	Status	Read Array	Program Setup	Erase Setup	Read Array			Read Status	Read Array	Read Identifier	
Erase Setup	"1"	Status	Erase Command Error			Erase (continue)	Erase Cmd. Error	Erase (continue)	Erase Command Error			
Erase Cmd. Error	"1"	Status	Read Array	Program Setup	Erase Setup	Read Array			Read Status	Read Array	Read Identifier	
Erase (continue)	"0"	Status	Erase (continue)				Erase Sus. to Read Status	Erase (continue)				
Erase Suspend to Status	"1"	Status	Erase Susp. to Read Array	Program Setup	Erase Susp. to Read Array	Erase	Erase Susp. to Read Array	Erase	Erase Susp. to Read Status	Erase Susp. to Read Array	Ers. Susp. to Read Identifier	
Erase Susp. to Read Array	"1"	Array	Erase Susp. to Read Array	Program Setup	Erase Susp. to Read Array	Erase	Erase Susp. to Read Array	Erase	Erase Susp. to Read Status	Erase Susp. to Read Array	Ers. Susp. to Read Identifier	
Erase Susp. to Read Identifier	"1"	Identifier	Erase Susp. to Read Array	Program Setup	Erase Susp. to Read Array	Erase	Erase Susp. to Read Array	Erase	Erase Susp. to Read Status	Erase Susp. to Read Array	Ers. Susp. to Read Identifier	
Erase (complete)	"1"	Status	Read Array	Program Setup	Erase Setup	Read Array			Read Status	Read Array	Read Identifier	

## Appendix B Architecture Block Diagram

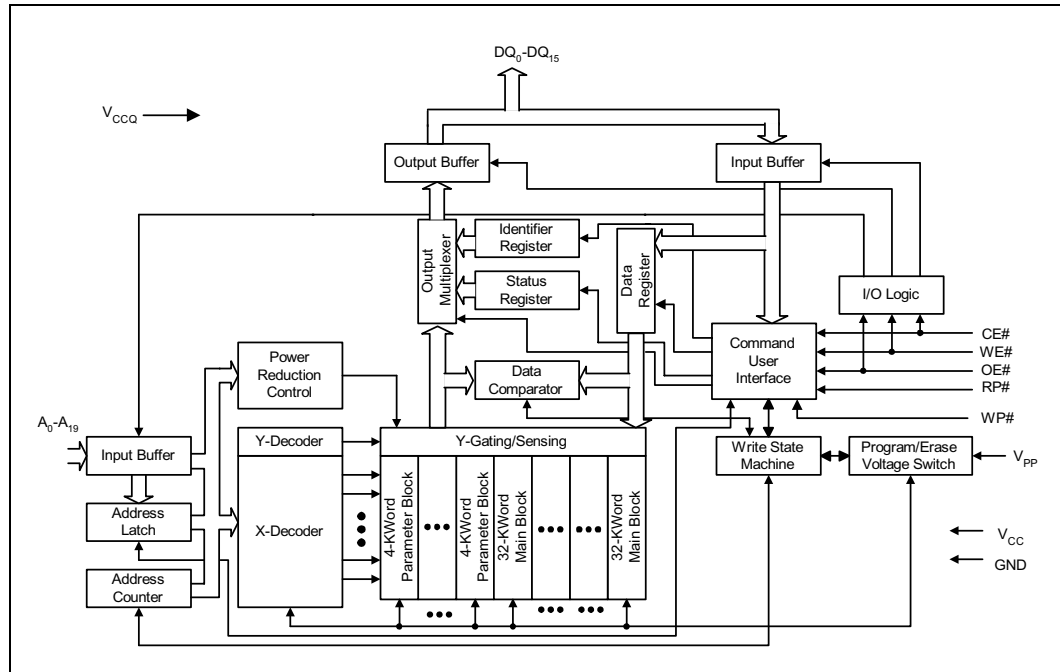

0580-C1



## Appendix C Word-Wide Memory Map Diagrams

16-Mbit and 32-Mbit Word-Wide Memory Addressing

Top Boot				Bottom Boot			
Size (KW)		16 Mbit	32 Mbit	Size (KW)	8 Mbit	16 Mbit	32 Mbit
4		FF000-FFFFF	1FF000-1FFFFFF	32			1F8000-1FFFFFF
4		FE000-FEFFF	1FE000-1FEFFF	32			1F0000-1F7FFF
4		FD000-FDFFF	1FD000-1FDFFF	32			1E8000-1E7FFF
4		FC000-FCFFF	1FC000-1FCFFF	32			1E0000-1E7FFF
4		FB000-FBFFF	1FB000-1FBFFF	32			1D8000-1D7FFF
4		FA000-FAFFF	1FA000-1FAFFF	32			1D0000-1D7FFF
4		F9000-F9FFF	1F9000-1F9FFF	32			1C8000-1C7FFF
4		F8000-F8FFF	1F8000-1F8FFF	32			1C0000-1C7FFF
32		F0000-F7FFF	1F0000-1F7FFF	32			1B8000-1B7FFF
32		E8000-E7FFF	1E8000-1E7FFF	32			1B0000-1B7FFF
32		E0000-E7FFF	1E0000-1E7FFF	32			1A8000-1A7FFF
32		D8000-D7FFF	1D8000-1D7FFF	32			1A0000-1A7FFF
32		D0000-D7FFF	1D0000-1D7FFF	32			198000-197FFF
32		C8000-C7FFF	1C8000-1C7FFF	32			190000-197FFF
32		C0000-C7FFF	1C0000-1C7FFF	32			188000-187FFF
32		B8000-B7FFF	1B8000-1B7FFF	32			180000-187FFF
32		B0000-B7FFF	1B0000-1B7FFF	32			178000-177FFF
32		A8000-A7FFF	1A8000-1A7FFF	32			170000-177FFF
32		A0000-A7FFF	1A0000-1A7FFF	32			168000-167FFF
32		98000-97FFF	198000-197FFF	32			160000-167FFF
32		90000-97FFF	190000-197FFF	32			158000-157FFF
32		88000-87FFF	188000-187FFF	32			150000-157FFF
32		80000-87FFF	180000-187FFF	32			148000-147FFF
32		78000-77FFF	178000-177FFF	32			140000-147FFF
32		70000-77FFF	170000-177FFF	32			138000-137FFF
32		68000-67FFF	168000-167FFF	32			130000-137FFF
32		60000-67FFF	160000-167FFF	32			128000-127FFF
32		58000-57FFF	158000-157FFF	32			120000-127FFF
32		50000-57FFF	150000-157FFF	32			118000-117FFF
32		48000-47FFF	148000-147FFF	32			110000-117FFF
32		40000-47FFF	140000-147FFF	32			108000-107FFF
32		38000-37FFF	138000-137FFF	32			100000-107FFF
32		30000-37FFF	130000-137FFF	32		F8000-FFFFF	0F8000-0FFFFF
32		28000-27FFF	128000-127FFF	32		F0000-F7FFF	0F0000-0F7FFF
32		20000-27FFF	120000-127FFF	32		E8000-E7FFF	0E8000-0E7FFF
32		18000-17FFF	118000-117FFF	32		E0000-E7FFF	0E0000-0E7FFF
32		10000-17FFF	110000-117FFF	32		D8000-D7FFF	0D8000-0D7FFF
32		08000-07FFF	108000-107FFF	32		D0000-D7FFF	0D0000-0D7FFF
32		00000-07FFF	100000-107FFF	32		C8000-C7FFF	0C8000-0C7FFF
This column continues on next page				This column continues on next page			



16-Mbit and 32-Mbit Word-Wide Memory Addressing (Continued)

Top Boot				Bottom Boot			
Size (KW)		16 Mbit	32 Mbit	Size (KW)		16 Mbit	32 Mbit
32			0F8000-0FFFFFF	32		C0000-C7FFF	0C0000-0C7FFF
32			0F0000-0F7FFF	32		B8000-BFFFF	0B8000-0BFFFF
32			0E8000-0EFFFF	32		B0000-B7FFF	0B0000-0B7FFF
32			0E0000-0E7FFF	32		A8000-AFFFF	0A8000-0AFFFF
32			0D8000-0DFFFF	32		A0000-A7FFF	0A0000-0A7FFF
32			0D0000-0D7FFF	32		98000-9FFFF	098000-09FFFF
32			0C8000-0CFFFF	32		90000-97FFF	090000-097FFF
32			0C0000-0C7FFF	32		88000-8FFFF	088000-08FFFF
32			0B8000-0BFFFF	32		80000-87FFF	080000-087FFF
32			0B0000-0B7FFF	32		78000-7FFFF	78000-7FFFF
32			0A8000-0AFFFF	32		70000-77FFF	70000-77FFF
32			0A0000-0A7FFF	32		68000-6FFFF	68000-6FFFF
32			098000-09FFFF	32		60000-67FFF	60000-67FFF
32			090000-097FFF	32		58000-5FFFF	58000-5FFFF
32			088000-08FFFF	32		50000-57FFF	50000-57FFF
32			080000-087FFF	32		48000-4FFFF	48000-4FFFF
32			078000-07FFFF	32		40000-47FFF	40000-47FFF
32			070000-077FFF	32		38000-3FFFF	38000-3FFFF
32			068000-06FFFF	32		30000-37FFF	30000-37FFF
32			060000-067FFF	32		28000-2FFFF	28000-2FFFF
32			058000-05FFFF	32		20000-27FFF	20000-27FFF
32			050000-057FFF	32		18000-1FFFF	18000-1FFFF
32			048000-04FFFF	32		10000-17FFF	10000-17FFF
32			040000-047FFF	32		08000-0FFFF	08000-0FFFF
32			038000-03FFFF	4		07000-07FFF	07000-07FFF
32			030000-037FFF	4		06000-06FFF	06000-06FFF
32			028000-02FFFF	4		05000-05FFF	05000-05FFF
32			020000-027FFF	4		04000-04FFF	04000-04FFF
32			018000-01FFFF	4		03000-03FFF	03000-03FFF
32			010000-017FFF	4		02000-02FFF	02000-02FFF
32			008000-00FFFF	4		01000-01FFF	01000-01FFF
32			000000-007FFF	4		00000-00FFF	00000-00FFF



4-Mbit and 8-Mbit Word-Wide Memory Addressing

Top Boot				Bottom Boot			
Size (KW)	4 Mbit			Size (KW)	4 Mbit	8 Mbit	
	3F000-3FFFF	7F000-7FFFF		32		78000-7FFFF	
	3E000-3EFFF	7E000-7EFFF		32		70000-77FFF	
	3D000-3DFFF	7D000-7DFFF		32		68000-6FFFF	
	3C000-3CFFF	7C000-7CFFF		32		60000-67FFF	
	3B000-3BFFF	7B000-7BFFF		32		58000-5FFFF	
	3A000-3AFFF	7A000-7AFFF		32		50000-57FFF	
	39000-39FFF	79000-79FFF		32		48000-4FFFF	
	38000-38FFF	78000-78FFF		32		40000-47FFF	
4	30000-37FFF	70000-77FFF		32	38000-3FFFF	38000-3FFFF	
4	28000-2FFFF	68000-6FFFF		32	30000-37FFF	30000-37FFF	
4	20000-27FFF	60000-67FFF		32	28000-2FFFF	28000-2FFFF	
4	18000-1FFFF	58000-5FFFF		32	20000-27FFF	20000-27FFF	
4	10000-17FFF	50000-57FFF		32	18000-1FFFF	18000-1FFFF	
4	08000-0FFFF	48000-4FFFF		32	10000-17FFF	10000-17FFF	
4	00000-07FFF	40000-47FFF		32	08000-0FFFF	08000-0FFFF	
4		38000-3FFFF		4	07000-07FFF	07000-07FFF	
32		30000-37FFF		4	06000-06FFF	06000-06FFF	
32		28000-2FFFF		4	05000-05FFF	05000-05FFF	
32		20000-27FFF		4	04000-04FFF	04000-04FFF	
32		18000-1FFFF		4	03000-03FFF	03000-03FFF	
32		10000-17FFF		4	02000-02FFF	02000-02FFF	
32		08000-0FFFF		4	01000-01FFF	01000-01FFF	
32		00000-07FFF		4	00000-00FFF	00000-00FFF	



16-Mbit, 32-Mbit, and 64-Mbit Word-Wide Memory Addressing

Top Boot				Bottom Boot			
Size (KW)	16 Mbit	32 Mbit	64 Mbit	Size (KW)	16 Mbit	32 Mbit	64 Mbit
4	FF000-FFFFF	1FF000-1FFFFFF	3FF000-3FFFFFF	32			3F8000-3FFFFFF
4	FE000-FEFFF	1FE000-1FEFFF	3FE000-3FEFFF	32			3F0000-3F7FFF
4	FD000-FDFFF	1FD000-1FDFFF	3FD000-3FDFFF	32			3E8000-3EFFFF
4	FC000-FCFFF	1FC000-1FCFFF	3FC000-3FCFFF	32			3E0000-3E7FFF
4	FB000-FBFFF	1FB000-1FBFFF	3FB000-3FBFFF	32			3D8000-3DFFFF
4	FA000-FAFFF	1FA000-1FAFFF	3FA000-3FAFFF	32			3D0000-3D7FFF
4	F9000-F9FFF	1F9000-1F9FFF	3F9000-3F9FFF	32			3C8000-3CFFFF
4	F8000-F8FFF	1F8000-1F8FFF	3F8000-3F8FFF	32			3C0000-3C7FFF
32	F0000-F7FFF	1F0000-1F7FFF	3F0000-3F7FFF	32			3B8000-3BFFFF
32	E8000-E7FFF	1E8000-1E7FFF	3E8000-3E7FFF	32			3B0000-3B7FFF
32	E0000-E7FFF	1E0000-1E7FFF	3E0000-3E7FFF	32			3A8000-3AFFFF
32	D8000-D7FFF	1D8000-1D7FFF	3D8000-3D7FFF	32			3A0000-3A7FFF
32	D0000-D7FFF	1D0000-1D7FFF	3D0000-3D7FFF	32			398000-39FFFF
32	C8000-C7FFF	1C8000-1C7FFF	3C8000-3C7FFF	32			390000-397FFF
32	C0000-C7FFF	1C0000-1C7FFF	3C0000-3C7FFF	32			388000-38FFFF
32	B8000-B7FFF	1B8000-1B7FFF	3B8000-3B7FFF	32			380000-387FFF
32	B0000-B7FFF	1B0000-1B7FFF	3B0000-3B7FFF	32			378000-377FFF
32	A8000-A7FFF	1A8000-1A7FFF	3A8000-3A7FFF	32			370000-377FFF
32	A0000-A7FFF	1A0000-1A7FFF	3A0000-3A7FFF	32			368000-36FFFF
32	98000-97FFF	198000-197FFF	398000-397FFF	32			360000-367FFF
32	90000-97FFF	190000-197FFF	390000-397FFF	32			358000-35FFFF
32	88000-87FFF	188000-187FFF	388000-387FFF	32			350000-357FFF
32	80000-87FFF	180000-187FFF	380000-387FFF	32			348000-347FFF
32	78000-77FFF	178000-177FFF	378000-377FFF	32			340000-347FFF
32	70000-77FFF	170000-177FFF	370000-377FFF	32			338000-33FFFF
32	68000-67FFF	168000-167FFF	368000-367FFF	32			330000-337FFF
32	60000-67FFF	160000-167FFF	360000-367FFF	32			328000-32FFFF
32	58000-57FFF	158000-157FFF	358000-357FFF	32			320000-327FFF
32	50000-57FFF	150000-157FFF	350000-357FFF	32			318000-317FFF
32	48000-47FFF	148000-147FFF	348000-347FFF	32			310000-317FFF
32	40000-47FFF	140000-147FFF	340000-347FFF	32			308000-30FFFF
32	38000-37FFF	138000-137FFF	338000-337FFF	32			300000-307FFF
32	30000-37FFF	130000-137FFF	330000-337FFF	32			2F8000-2F7FFF
32	28000-27FFF	128000-127FFF	328000-327FFF	32			2F0000-2F7FFF
32	20000-27FFF	120000-127FFF	320000-327FFF	32			2E8000-2E7FFF
32	18000-17FFF	118000-117FFF	318000-317FFF	32			2E0000-2E7FFF
32	10000-17FFF	110000-117FFF	310000-317FFF	32			2D8000-2D7FFF
32	08000-07FFF	108000-107FFF	308000-307FFF	32			2D0000-2D7FFF
32	00000-07FFF	100000-107FFF	300000-307FFF	32			2C8000-2C7FFF
32		0F8000-0FFFFF	2F8000-2F7FFF	32			2C0000-2C7FFF
32		0F0000-0F7FFF	2F0000-2F7FFF	32			2B8000-2B7FFF
32		0E8000-0EFFFF	2E8000-2E7FFF	32			2B0000-2B7FFF
32		0E0000-0E7FFF	2E0000-2E7FFF	32			2A8000-2A7FFF
32		0D8000-0DFFFF	2D8000-2D7FFF	32			2A0000-2A7FFF
32		0D0000-0D7FFF	2D0000-2D7FFF	32			298000-297FFF
32		0C8000-0CFFFF	2C8000-2C7FFF	32			290000-297FFF
32		0C0000-0C7FFF	2C0000-2C7FFF	32			288000-287FFF
32		0B8000-0BFFFF	2B8000-2B7FFF	32			280000-287FFF
32		0B0000-0B7FFF	2B0000-2B7FFF	32			278000-277FFF

This column continues on next page

This column continues on next page



16-Mbit, 32-Mbit, and 64-Mbit Word-Wide Memory Addressing (Continued)

Top Boot				Bottom Boot			
Size (KW)	16 Mbit	32 Mbit	64 Mbit	Size (KW)	16 Mbit	32 Mbit	64 Mbit
32		0A8000-0AFFFF	2A8000-2AFFFF	32			270000-277FFF
32		0A0000-0A7FFF	2A0000-2A7FFF	32			268000-26FFFF
32		098000-09FFFF	298000-29FFFF	32			260000-267FFF
32		090000-097FFF	290000-297FFF	32			258000-25FFFF
32		088000-08FFFF	288000-28FFFF	32			250000-257FFF
32		080000-087FFF	280000-287FFF	32			248000-24FFFF
32		078000-07FFFF	278000-27FFFF	32			240000-247FFF
32		070000-077FFF	270000-277FFF	32			238000-23FFFF
32		068000-06FFFF	268000-26FFFF	32			230000-237FFF
32		060000-067FFF	260000-267FFF	32			228000-22FFFF
32		058000-05FFFF	258000-25FFFF	32			220000-227FFF
32		050000-057FFF	250000-257FFF	32			218000-21FFFF
32		048000-04FFFF	248000-24FFFF	32			210000-217FFF
32		040000-047FFF	240000-247FFF	32			208000-20FFFF
32		038000-03FFFF	238000-23FFFF	32			200000-207FFF
32		030000-037FFF	230000-237FFF	32		1F8000-1FFFFF	1F8000-1FFFFF
32		028000-02FFFF	228000-22FFFF	32		1F0000-1F7FFF	1F0000-1F7FFF
32		020000-027FFF	220000-227FFF	32		1E8000-1EFFFF	1E8000-1EFFFF
32		018000-01FFFF	218000-21FFFF	32		1E0000-1E7FFF	1E0000-1E7FFF
32		010000-017FFF	210000-217FFF	32		1D8000-1DFFFF	1D8000-1DFFFF
32		008000-00FFFF	208000-21FFFF	32		1D0000-1D7FFF	1D0000-1D7FFF
32		000000-007FFF	200000-207FFF	32		1C8000-1CFFFF	1C8000-1CFFFF
32			1F8000-1FFFFF	32		1C0000-1C7FFF	1C0000-1C7FFF
32			1F0000-1F7FFF	32		1B8000-1BFFFF	1B8000-1BFFFF
32			1E8000-1EFFFF	32		1B0000-1B7FFF	1B0000-1B7FFF
32			1E0000-1E7FFF	32		1A8000-1AFFFF	1A8000-1AFFFF
32			1D8000-1DFFFF	32		1A0000-1A7FFF	1A0000-1A7FFF
32			1D0000-1D7FFF	32		198000-19FFFF	198000-19FFFF
32			1C8000-1CFFFF	32		190000-197FFF	190000-197FFF
32			1C0000-1C7FFF	32		188000-18FFFF	188000-18FFFF
32			1B8000-1BFFFF	32		180000-187FFF	180000-187FFF
32			1B0000-1B7FFF	32		178000-17FFFF	178000-17FFFF
32			1A8000-1AFFFF	32		170000-177FFF	170000-177FFF
32			1A0000-1A7FFF	32		168000-16FFFF	168000-16FFFF
32			198000-19FFFF	32		160000-167FFF	160000-167FFF
32			190000-197FFF	32		158000-15FFFF	158000-15FFFF
32			188000-18FFFF	32		150000-157FFF	150000-157FFF
32			180000-187FFF	32		148000-14FFFF	148000-14FFFF
32			178000-17FFFF	32		140000-147FFF	140000-147FFF
32			170000-177FFF	32		138000-13FFFF	138000-13FFFF
32			168000-16FFFF	32		130000-137FFF	130000-137FFF
32			160000-167FFF	32		128000-12FFFF	128000-12FFFF
32			158000-15FFFF	32		120000-127FFF	120000-127FFF
32			150000-157FFF	32		118000-11FFFF	118000-11FFFF
32			148000-14FFFF	32		110000-117FFF	110000-117FFF
32			140000-147FFF	32		108000-10FFFF	108000-10FFFF
32			138000-13FFFF	32		100000-107FFF	100000-107FFF
32			130000-137FFF	32	F8000-FFFFF	F8000-FFFFF	F8000-FFFFF
32			128000-12FFFF	32	F0000-F7FFF	F0000-F7FFF	F0000-F7FFF
32			120000-127FFF	32	E8000-EFFFF	E8000-EFFFF	E8000-EFFFF
32			118000-11FFFF	32	E0000-E7FFF	E0000-E7FFF	E0000-E7FFF
32			110000-117FFF	32	D8000-DFFFF	D8000-DFFFF	D8000-DFFFF
32			108000-10FFFF	32	D0000-D7FFF	D0000-D7FFF	D0000-D7FFF
32			100000-107FFF	32	C8000-CFFFF	C8000-CFFFF	C8000-CFFFF
This column continues on next page				This column continues on next page			



16-Mbit, 32-Mbit, and 64-Mbit Word-Wide Memory Addressing (Continued)

Top Boot				Bottom Boot			
Size (KW)	16 Mbit	32 Mbit	64 Mbit	Size (KW)	16 Mbit	32 Mbit	64 Mbit
32			0F8000-0FFFFF	32	C0000-C7FFF	C0000-C7FFF	C0000-C7FFF
32			0F0000-0F7FFF	32	B8000-BFFFF	B8000-BFFFF	B8000-BFFFF
32			0E8000-0EFFFF	32	B0000-B7FFF	B0000-B7FFF	B0000-B7FFF
32			0E0000-0E7FFF	32	A8000-AFFFF	A8000-AFFFF	A8000-AFFFF
32			0D8000-0DFFFF	32	A0000-A7FFF	A0000-A7FFF	A0000-A7FFF
32			0D0000-0D7FFF	32	98000-9FFFF	98000-9FFFF	98000-9FFFF
32			0C8000-0CFFFF	32	90000-97FFF	90000-97FFF	90000-97FFF
32			0C0000-0C7FFF	32	88000-8FFFF	88000-8FFFF	88000-8FFFF
32			0B8000-0BFFFF	32	80000-87FFF	80000-87FFF	80000-87FFF
32			0B0000-0B7FFF	32	78000-7FFFF	78000-7FFFF	78000-7FFFF
32			0A8000-0AFFFF	32	70000-77FFF	70000-77FFF	70000-77FFF
32			0A0000-0A7FFF	32	68000-6FFFF	68000-6FFFF	68000-6FFFF
32			098000-09FFFF	32	60000-67FFF	60000-67FFF	60000-67FFF
32			090000-097FFF	32	58000-5FFFF	58000-5FFFF	58000-5FFFF
32			088000-08FFFF	32	50000-57FFF	50000-57FFF	50000-57FFF
32			080000-087FFF	32	48000-4FFFF	48000-4FFFF	48000-4FFFF
32			078000-077FFF	32	40000-47FFF	40000-47FFF	40000-47FFF
32			070000-077FFF	32	38000-3FFFF	38000-3FFFF	38000-3FFFF
32			068000-06FFFF	32	30000-37FFF	30000-37FFF	30000-37FFF
32			060000-067FFF	32	28000-2FFFF	28000-2FFFF	28000-2FFFF
32			058000-05FFFF	32	20000-27FFF	20000-27FFF	20000-27FFF
32			050000-057FFF	32	18000-1FFFF	18000-1FFFF	18000-1FFFF
32			048000-04FFFF	32	10000-17FFF	10000-17FFF	10000-17FFF
32			040000-047FFF	32	08000-0FFFF	08000-0FFFF	08000-0FFFF
32			038000-03FFFF	4	07000-07FFF	07000-07FFF	07000-07FFF
32			030000-037FFF	4	06000-06FFF	06000-06FFF	06000-06FFF
32			028000-02FFFF	4	05000-05FFF	05000-05FFF	05000-05FFF
32			020000-027FFF	4	04000-04FFF	04000-04FFF	04000-04FFF
32			018000-01FFFF	4	03000-03FFF	03000-03FFF	03000-03FFF
32			010000-017FFF	4	02000-02FFF	02000-02FFF	02000-02FFF
32			008000-00FFFF	4	01000-01FFF	01000-01FFF	01000-01FFF
32			000000-007FFF	4	00000-00FFF	00000-00FFF	00000-00FFF



## Appendix D Byte-Wide Memory Map Diagrams

8-Mbit and 16-Mbit Byte-Wide Memory Addressing

Top Boot			Bottom Boot		
Size (KB)	8 Mbit	16 Mbit	Size (KB)	8 Mbit	16 Mbit
8	FE000-FFFFF	1FE000-1FFFFFF	64		
8	FC000-FDFFF	1FC000-1FDFFF	64		
8	FA000-FBFFF	1FA000-1FBFFF	64		
8	F8000-F9FFF	1F8000-1F9FFF	64		
8	F6000-F7FFF	1F6000-1F7FFF	64		
8	F4000-F5FFF	1F4000-1F5FFF	64		
8	F2000-F3FFF	1F2000-1F3FFF	64		
8	F0000-F1FFF	1F0000-1F1FFF	64		
64	E0000-EFFFF	1E0000-1EFFFF	64		
64	D0000-DFFFF	1D0000-1DFFFF	64		
64	C0000-CFFFF	1C0000-1CFFFF	64		
64	B0000-BFFFF	1B0000-1BFFFF	64		
64	A0000-AFFFF	1A0000-1AFFFF	64		
64	90000-9FFFF	190000-19FFFF	64		
64	80000-8FFFF	180000-18FFFF	64		
64	70000-7FFFF	170000-17FFFF	64		
64	60000-6FFFF	160000-16FFFF	64		
64	50000-5FFFF	150000-15FFFF	64		
64	40000-4FFFF	140000-14FFFF	64		
64	30000-3FFFF	130000-13FFFF	64		
64	20000-2FFFF	120000-12FFFF	64		
64	10000-1FFFF	110000-11FFFF	64		
64	00000-0FFFF	100000-10FFFF	64		
64		0F0000-0FFFFFF	64		
64		0E0000-0EFFFF	64		
64		0D0000-0DFFFF	64		
64		0C0000-0CFFFF	64		
64		0B0000-0BFFFF	64		
64		0A0000-0AFFFF	64		
64		090000-09FFFF	64		
64		080000-08FFFF	64		
64		070000-07FFFF	64		
64		060000-06FFFF	64		1F0000-1FFFFFF
64		050000-05FFFF	64		1E0000-1EFFFF
64		040000-04FFFF	64		1D0000-1DFFFF
64		030000-03FFFF	64		1C0000-1CFFFF
64		020000-02FFFF	64		1B0000-1BFFFF
64		010000-01FFFF	64		1A0000-1AFFFF
64		000000-00FFFF	64		190000-19FFFF
This column continues on next page			This column continues on next page		



8-Mbit and 16-Mbit Byte-Wide Memory Addressing (Continued)

Top Boot			Bottom Boot		
Size (KB)	8 Mbit	16 Mbit	Size (KB)	8 Mbit	16 Mbit
64			64		180000-18FFFF
64			64		170000-17FFFF
64			64		160000-16FFFF
64			64		150000-15FFFF
64			64		140000-14FFFF
64			64		130000-13FFFF
64			64		120000-12FFFF
64			64		110000-11FFFF
64			64		100000-10FFFF
64			64	F0000-FFFFF	0F0000-0FFFFF
64			64	E0000-EFFFF	0E0000-0EFFFF
64			64	D0000-DFFFF	0D0000-0DFFFF
64			64	C0000-CFFFF	0C0000-0CFFFF
64			64	B0000-BFFFF	0B0000-0BFFFF
64			64	A0000-AFFFF	0A0000-0AFFFF
64			64	90000-9FFFF	090000-09FFFF
64			64	80000-8FFFF	080000-08FFFF
64			64	70000-7FFFF	070000-07FFFF
64			64	60000-6FFFF	060000-06FFFF
64			64	50000-5FFFF	050000-05FFFF
64			64	40000-4FFFF	040000-04FFFF
64			64	30000-3FFFF	030000-03FFFF
64			64	20000-2FFFF	020000-02FFFF
64			64	10000-1FFFF	010000-01FFFF
64			8	0E000-0FFFF	00E000-00FFFF
64			8	0C000-0DFFF	00C000-00DFFF
64			8	0A000-0BFFF	00A000-00BFFF
64			8	08000-09FFF	008000-009FFF
64			8	06000-07FFF	006000-007FFF
64			8	04000-05FFF	004000-005FFF
64			8	02000-03FFF	002000-003FFF
64			8	00000-01FFF	000000-001FFF

**4-Mbit Byte-Wide Memory Addressing**

Top Boot				Bottom Boot			
Size (KB)	4 Mbit			Size (KB)	4 Mbit		
8	7E000-7FFFF			64	70000-7FFFF		
8	7C000-7DFFF			64	60000-6FFFF		
8	7A000-7BFFF			64	50000-5FFFF		
8	78000-79FFF			64	40000-4FFFF		
8	76000-77FFF			64	30000-3FFFF		
8	74000-75FFF			64	20000-2FFFF		
8	72000-73FFF			64	10000-1FFFF		
8	70000-71FFF			8	0E000-0FFFF		
64	60000-6FFFF			8	0C000-0DFFF		
64	50000-5FFFF			8	0A000-0BFFF		
64	40000-4FFFF			8	08000-09FFF		
64	30000-3FFFF			8	06000-07FFF		
64	20000-2FFFF			8	04000-05FFF		
64	10000-1FFFF			8	02000-03FFF		
64	00000-0FFFF			8	00000-01FFF		

## Appendix E Program and Erase Flowcharts

Figure 12. Program Flowchart

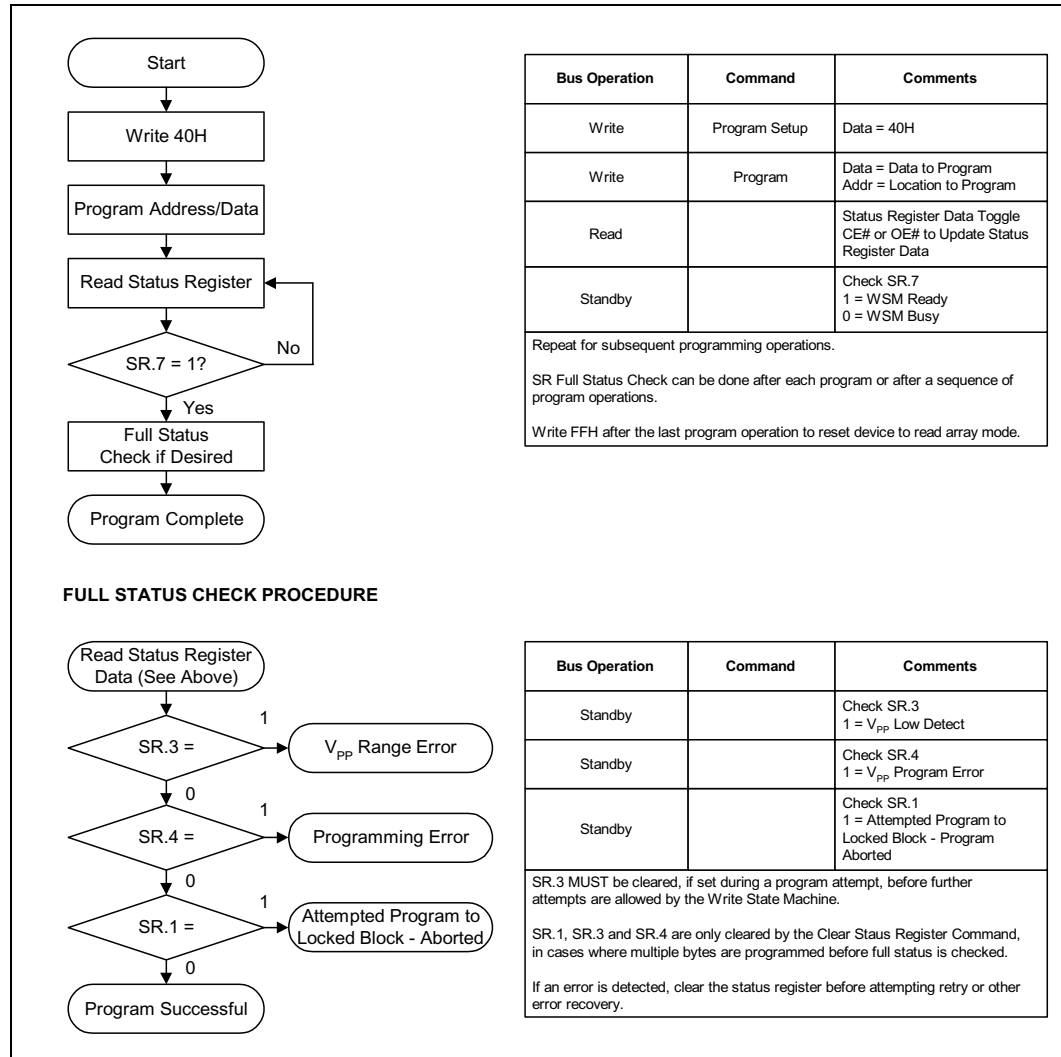

0580\_E1

Figure 13. Program Suspend/Resume Flowchart

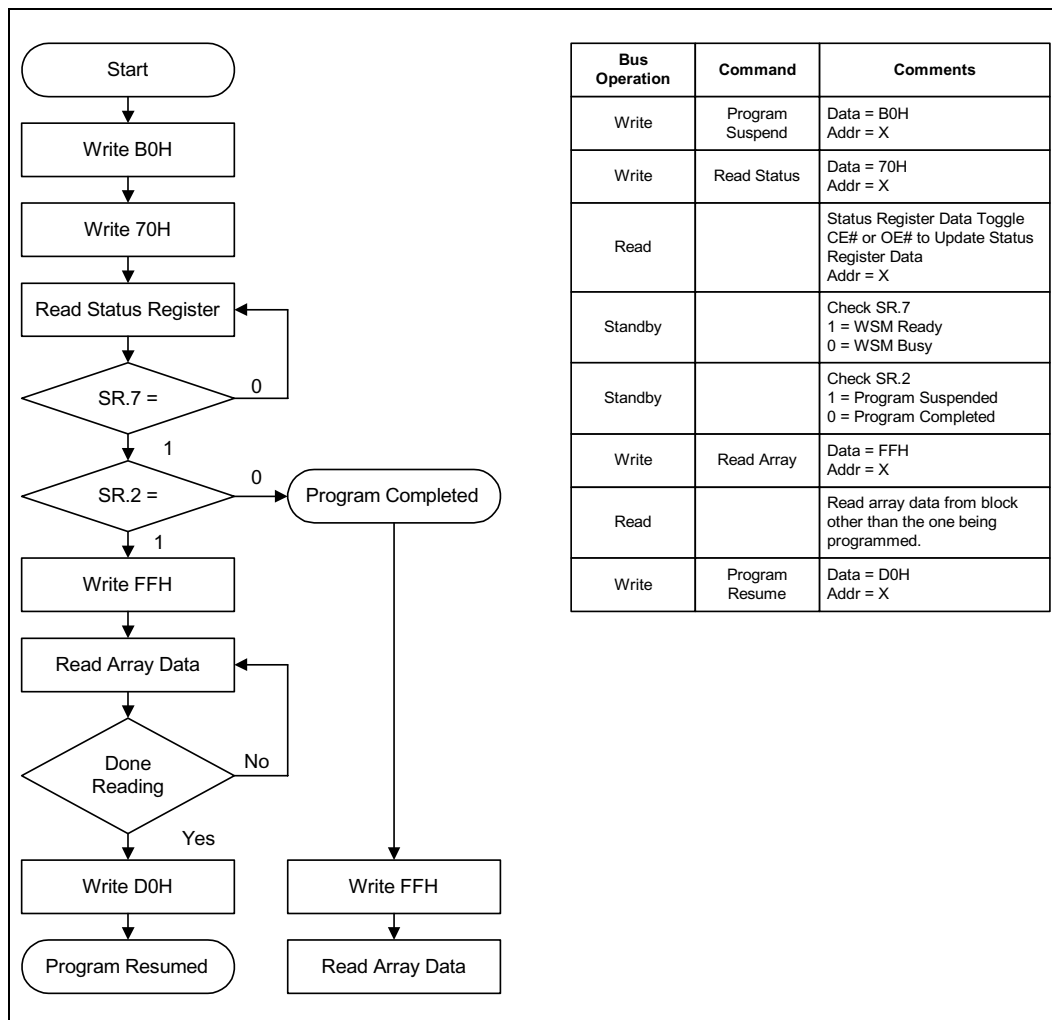

0580\_E2

Figure 14. Block Erase Flowchart

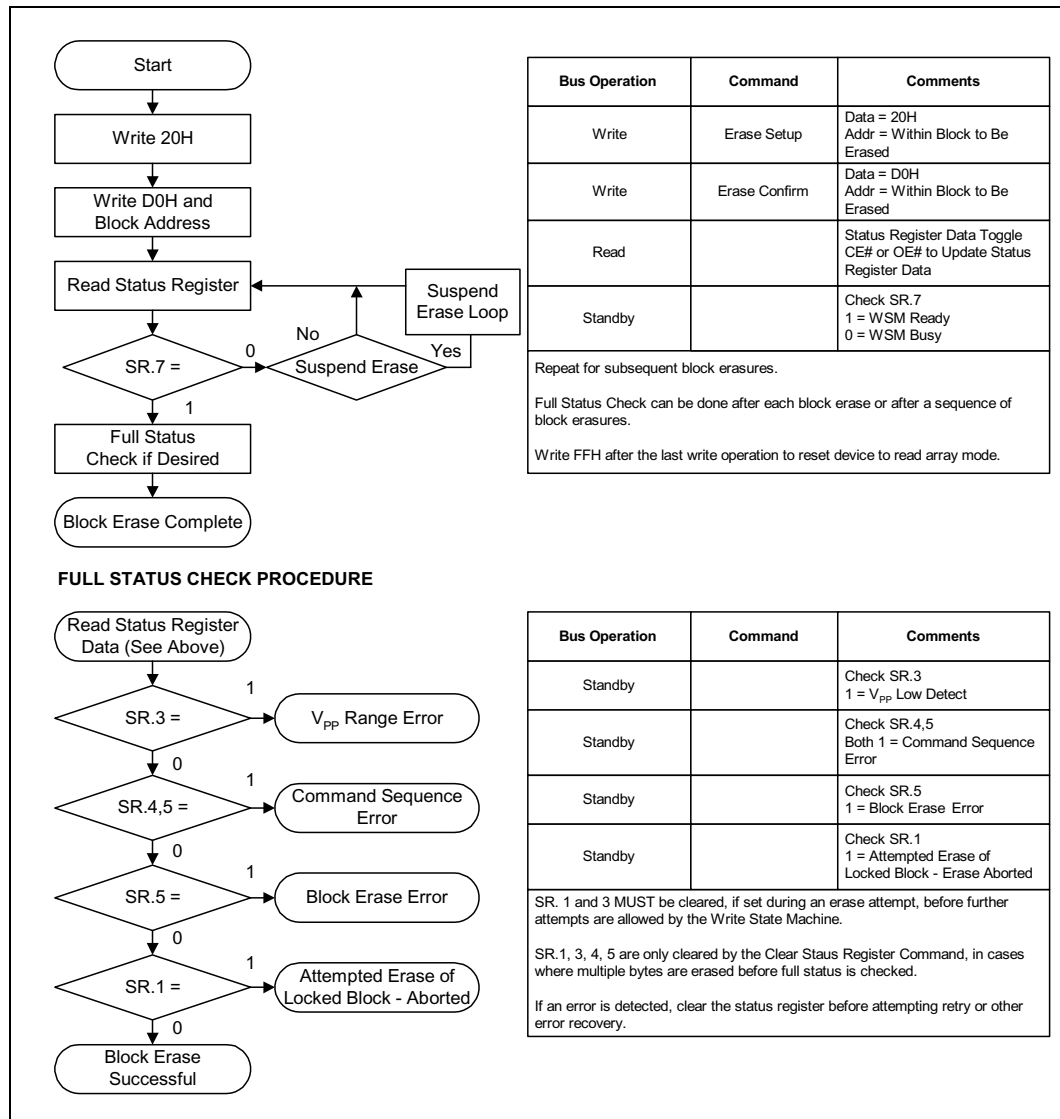
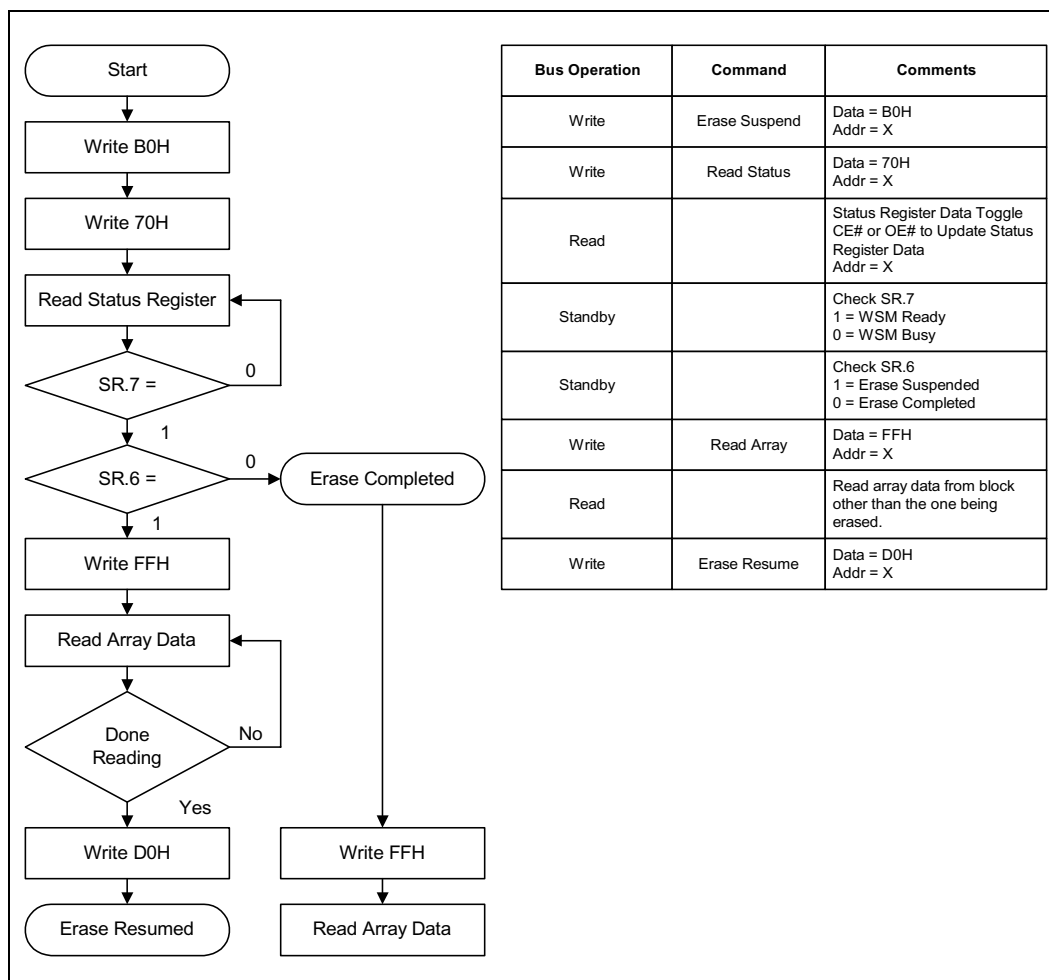

Figure 15. Erase Suspend/Resume Flowchart



0580\_E4

Figure 16. Very Fine Pitch BGA (VF BGA) Package Drawing and Dimensions

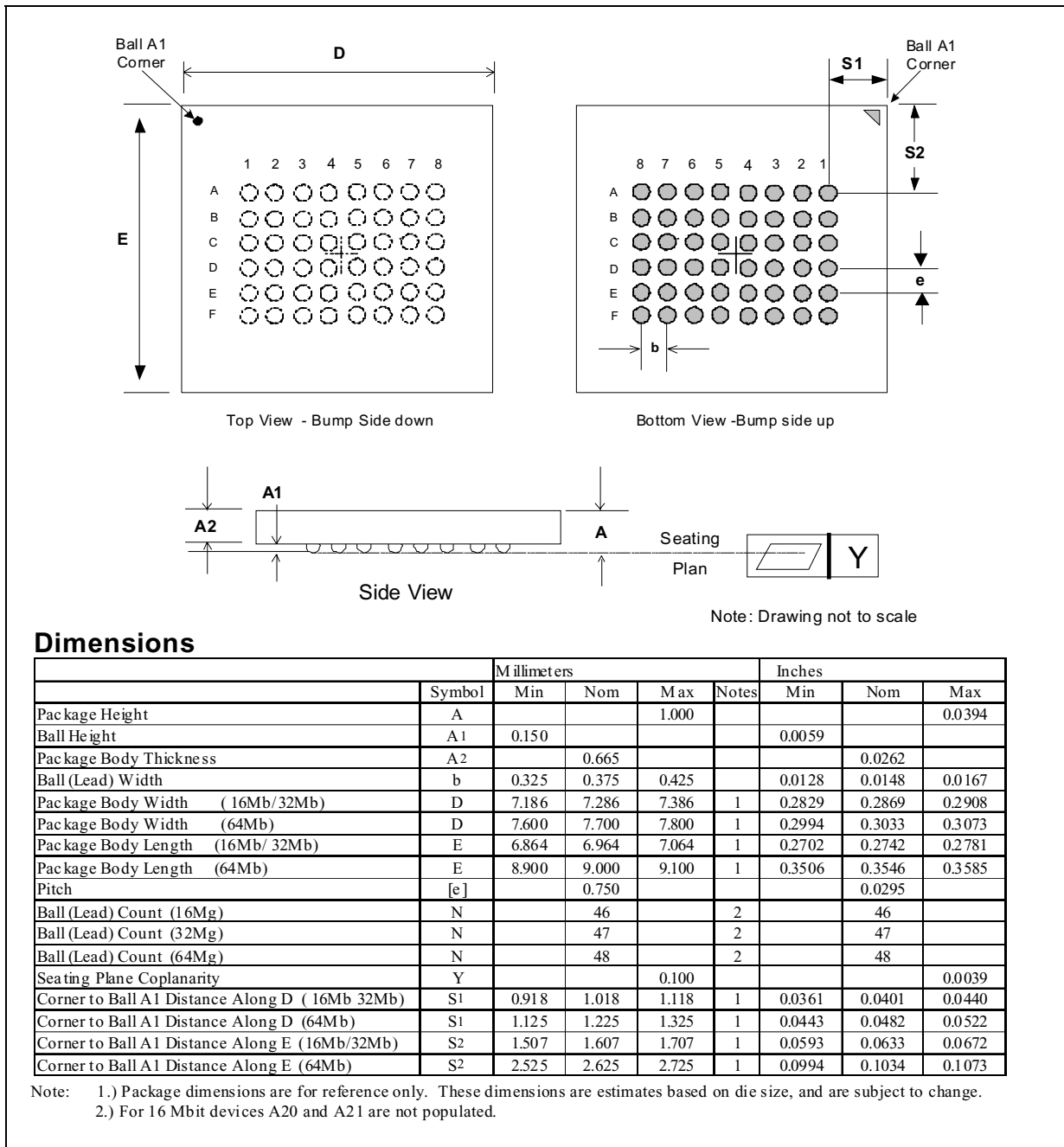
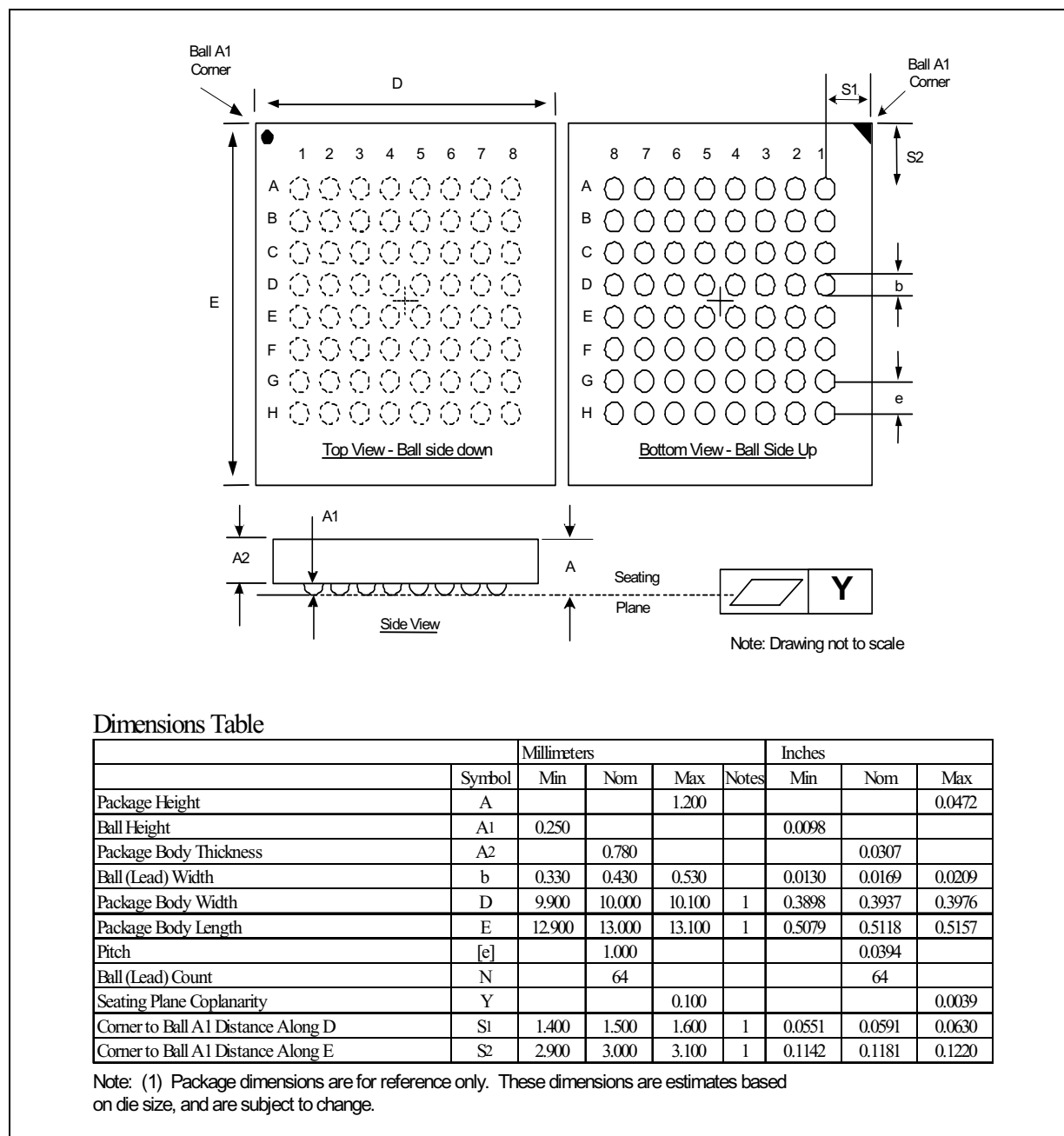

Figure 17. Easy BGA Package Drawing and Dimensions



Dimensions Table

	Symbol	Millimeters				Inches		
		Min	Nom	Max	Notes	Min	Nom	Max
Package Height	A			1.200				0.0472
Ball Height	A1	0.250				0.0098		
Package Body Thickness	A2		0.780				0.0307	
Ball (Lead) Width	b	0.330	0.430	0.530		0.0130	0.0169	0.0209
Package Body Width	D	9.900	10.000	10.100	1	0.3898	0.3937	0.3976
Package Body Length	E	12.900	13.000	13.100	1	0.5079	0.5118	0.5157
Pitch	[e]		1.000				0.0394	
Ball (Lead) Count	N		64				64	
Seating Plane Coplanarity	Y			0.100				0.0039
Corner to Ball A1 Distance Along D	S1	1.400	1.500	1.600	1	0.0551	0.0591	0.0630
Corner to Ball A1 Distance Along E	S2	2.900	3.000	3.100	1	0.1142	0.1181	0.1220

Note: (1) Package dimensions are for reference only. These dimensions are estimates based on die size, and are subject to change.

## Looking for pricing, stock, or lifecycle information?

Click below to explore more details on WIN SOURCE:

 [View GT28F320B3TA100 on WIN SOURCE](#)

 [Intel Information](#)

## Optimize Your Supply Chain with WIN SOURCE Solutions

-  Global Sourcing Solution
-  Obsolete Management
-  Cost Control Management
-  Shortage Management
-  Alternative Solution
-  Excess Inventory Management