



**THE DATASHEET OF  
NCN5192MNRG**



# NCN5192

## HART Modem

### Description

The NCN5192 is a single-chip, CMOS modem for use in highway addressable remote transducer (HART) field instruments and masters. The modem and a few external passive components provide all of the functions needed to satisfy HART physical layer requirements including modulation, demodulation, receive filtering, carrier detect, and transmit-signal shaping. In addition, the NCN5192 also has an integrated DAC for low-BOM current loop slave transmitter implementation.

The NCN5192 uses phase continuous frequency shift keying (FSK) at 1200 bits per second. To conserve power the receive circuits are disabled during transmit operations and vice versa. This provides the half-duplex operation used in HART communications.

### Features

- Single-chip, Half-duplex 1200 Bits per Second FSK Modem
- Bell 202 Shift Frequencies of 1200 Hz and 2200 Hz
- 3.0 V – 5.5 V Power Supply
- Transmit-signal Wave Shaping
- Receive Band-pass Filter
- Low Power: Optimal for Intrinsically Safe Applications
- Compatible with 3.3 V or 5 V Microcontroller
- Internal Oscillator Requires 460.8 kHz, 920 kHz or 1.8 MHz Crystal or Ceramic Resonator
- SPI Communication
- Integrated 16 bit Sigma-Delta DAC
- Meets HART Physical Layer Requirements
- Industrial Temperature Range of –40°C to +85°C
- Available in 32-pin NQFP Package
- These are Pb-Free Devices

### Applications

- HART Multiplexers
- HART Modem Interfaces
- 4 – 20 mA Loop Powered Transmitters



**ON Semiconductor®**

[www.onsemi.com](http://www.onsemi.com)

### MARKING DIAGRAM

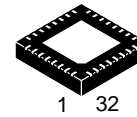

QFN32  
CASE 488AM

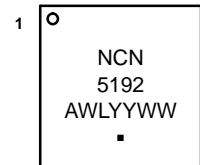

NCN5192 = Specific Device Code  
A = Assembly Location  
WL = Wafer Lot  
YY = Year  
WW = Work Week  
▪ = Pb-Free Package

### ORDERING INFORMATION

See detailed ordering and shipping information in the package dimensions section on page 12 of this data sheet.

# NCN5192

## BLOCK DIAGRAM

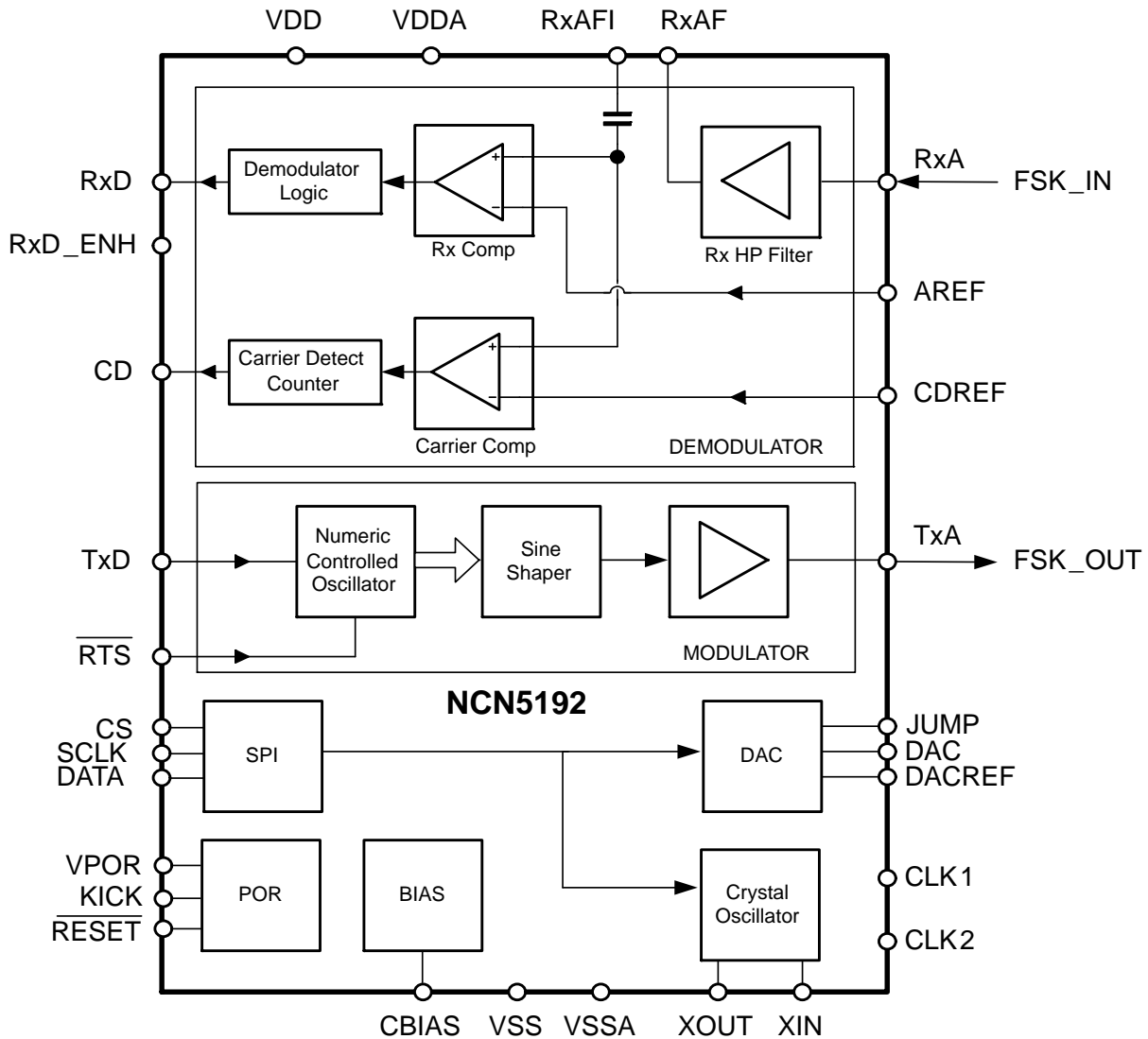

Figure 1. Block Diagram NCN5192

## ELECTRICAL SPECIFICATIONS

Table 1. ABSOLUTE MAXIMUM RATINGS (Note 1)

Symbol	Parameter	Min	Max	Units
T <sub>A</sub>	Ambient Temperature	-40	+85	°C
T <sub>S</sub>	Storage Temperature	-55	+150	°C
T <sub>J</sub>	Junction Temperature	-40	+85	°C
V <sub>DD</sub>	Supply Voltage	-0.3	6.0	V
V <sub>IN</sub> , V <sub>OUT</sub>	DC Input, Output	-0.3	V <sub>DD</sub> + 0.3	V

Stresses exceeding those listed in the Maximum Ratings table may damage the device. If any of these limits are exceeded, device functionality should not be assumed, damage may occur and reliability may be affected.

- CMOS devices are damaged by high-energy electrostatic discharge. Devices must be stored in conductive foam or with all pins shunted. Precautions should be taken to avoid application of voltages higher than the maximum rating. Stresses above absolute maximum ratings may result in damage to the device.

# NCN5192

**Table 2. DC CHARACTERISTICS** ( $V_{DD} = 3.0\text{ V to }5.5\text{ V}$ ,  $V_{SS} = 0\text{ V}$ ,  $T_A = -40^\circ\text{C to }+85^\circ\text{C}$ )

Symbol	Parameter	$V_{DD}$	Min	Typ	Max	Units
$V_{DD}$	DC Supply Voltage		3.0		5.5	V
$V_{IL}$	Input Voltage, Low	3.0 – 5.5 V			$0.3 * V_{DD}$	V
$V_{IH}$	Input Voltage, High	3.0 – 5.5 V	$0.7 * V_{DD}$			V
$V_{OL}$	Output Voltage, Low ( $I_{OL} = 0.67\text{ mA}$ )	3.0 – 5.5 V			0.4	V
$V_{OH}$	Output Voltage, High ( $I_{OH} = -0.67\text{ mA}$ )	3.0 – 5.5 V	2.4			V
$C_{IN}$	Input Capacitance of: Analog Inputs RxA Digital Inputs			2.9 25 3.5		pF pF pF
$I_{IL}/I_{IH}$	Input Leakage Current				$\pm 500$	nA
$I_{OLL}$	Output Leakage Current				$\pm 10$	$\mu\text{A}$
$I_{DD}$	Total Power Supply Current		175	350	600	$\mu\text{A}$
$I_{DDA}$	Static Analog Supply Current	3.3 V 5.0 V	150 150		330 370	$\mu\text{A}$ $\mu\text{A}$
$I_{DDQ}$	Static Digital Current		0		30	$\mu\text{A}$
$I_{DDD}$	Dynamic Digital Current	5.0 V	25		200	$\mu\text{A}$
$A_{REF}$	Analog Reference	3.3 V 5.0 V	1.2	1.235 2.5	2.6	V V
$CD_{REF}$ (Note 2)	Carrier Detect Reference ( $A_{REF} - 0.08\text{ V}$ )	3.3 V 5.0 V		1.15 2.42		V
$C_{BIAS}$	Comparator Bias Current ( $R_{BIAS} = 500\text{ k}\Omega$ , $A_{REF} = 1.235\text{ V}$ )			2.5		$\mu\text{A}$

2. The HART specification requires carrier detect (CD) to be active between 80 and 120 mVp-p. Setting  $CD_{REF}$  at  $A_{REF} - 0.08\text{ VDC}$  will set the carrier detect to a nominal 100 mVp-p.

**Table 3. AC CHARACTERISTICS** ( $V_{DD} = 3.0\text{ V to }5.5\text{ V}$ ,  $V_{SS} = 0\text{ V}$ ,  $T_A = -40^\circ\text{C to }+85^\circ\text{C}$ ) (Note 3)

Pin Name	Description	Min	Typ	Max	Units
RxA	Receive analog input Leakage current Frequency – mark (logic 1) Frequency – space (logic 0)	1190 2180	1200 2200	$\pm 150$ 1210 2220	nA Hz Hz
RxAF	Output of the high-pass filter Slew rate Gain bandwidth (GBW) Voltage range	150 0.15	0.025	$V_{DD} - 0.15$	V/ $\mu\text{s}$ kHz V
RxAFI	Carrier detect and receive filter input Leakage current			$\pm 500$	nA
TxA	Modulator output Frequency – mark (logic 1) Frequency – space (logic 0) Amplitude ( $I_{AREF} = 1.235\text{ V}$ ) Slew Rate – mark (logic 1) Slew Rate – space (logic 0) Loading ( $I_{AREF} = 1.235\text{ V}$ )	30	1196.9 2194.3 500 1860 3300		Hz Hz mV V/s V/s k $\Omega$
RxD	Receive digital output Rise/fall time	20			ns
CD	Carrier detect output Rise/fall time	20			ns

3. The modulator output frequencies are proportional to the input clock frequency (460.8 kHz/920 kHz/1.8 MHz).

Product parametric performance is indicated in the Electrical Characteristics for the listed test conditions, unless otherwise noted. Product performance may not be indicated by the Electrical Characteristics if operated under different conditions.

# NCN5192

**Table 4. MODEM CHARACTERISTICS** ( $V_{DD} = 3.0\text{ V to }5.5\text{ V}$ ,  $V_{SS} = 0\text{ V}$ ,  $T_A = -40^\circ\text{C to }+85^\circ\text{C}$ )

Parameter	Min	Typ	Max	Units
Demodulator jitter Conditions 1. Input frequencies at $1200\text{ Hz} \pm 10\text{ Hz}$ , $2200\text{ Hz} \pm 20\text{ Hz}$ 2. Clock frequency of $460.8\text{ kHz} \pm 0.1\%$ 3. Input (RxA) asymmetry, 0			12	% of 1 bit

**Table 5. CERAMIC RESONATOR AND CRYSTAL – External Clock Specifications**

( $V_{DD} = 3.0\text{ V to }5.5\text{ V}$ ,  $V_{SS} = 0\text{ V}$ ,  $T_A = -40^\circ\text{C to }+85^\circ\text{C}$ )

Parameter	Min	Typ	Max	Units
Resonator Tolerance Frequency		460.8	1.0	% kHz
Crystal or Resonator, 920 kHz Tolerance Frequency		921.6	1.0	% kHz
Crystal, 1.8 MHz Tolerance Frequency		1.843	1.0	% MHz
External Duty cycle Amplitude	40	50 $V_{OH} - V_{OL}$	60	% V

**Table 6. DAC CHARACTERISTICS** ( $V_{DD} = 3.0\text{ V to }5.5\text{ V}$ ,  $V_{SS} = 0\text{ V}$ ,  $T_A = -40^\circ\text{C to }+85^\circ\text{C}$ )

Parameter	Min	Typ	Max	Units
Bandwidth		10		Hz
Accuracy Return-to-Zero Non Return-to-Zero		16 14		Bit Bit
Maximum Output Return-to-Zero Non Return-to-Zero		$AV_{DD}/2$ $AV_{DD}$		V V
Differential Non-linearity Return-to-Zero Non Return-to-Zero		0.5 0.25	0.75 0.75	LSB LSB
Integral Non-linearity Return-to-Zero Non Return-to-Zero		2.0 1.0	4.0 2.0	LSB LSB



# NCN5192

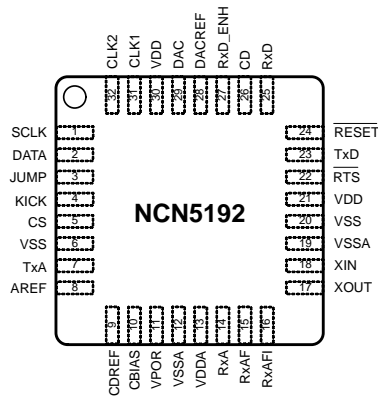

Figure 3. Pin Out NCN5192 in 32-pin NQFP (top view)

Table 7. PIN OUT SUMMARY 32-PIN NQFP

Pin No.	Signal Name	Type	Pin Description
1	SCLK	Input	SPI Serial Clock
2	DATA	Input	SPI Serial Data
3	JUMP	Input	Sigma-Delta Modulator Alarm condition value
4	KICK	Input	Watchdog kick
5	CS	Input	SPI Serial Chip Select
6	VSS	Ground	Ground
7	TxA	Output	Transmit Data Modulator output
8	AREF	Input	Analog reference voltage
9	CDREF	Input	Carrier detect reference voltage
10	CBIAS	Output	Comparator bias current
11	VPOR	Input	POR measurement point
12	VSSA	Ground	Analog ground
13	VDDA	Power	Analog supply voltage
14	RxA	Input	Receive Data Modulator input
15	RxAF	Output	Analog receive filter output
16	RxAFI	Input	Analog receive comparator input
17	XOUT	Output	Crystal oscillator output
18	XIN	Input	Crystal oscillator input
19	VSSA	Ground	Analog ground
20	VSS	Ground	Ground
21	VDD	Power	Digital supply voltage
22	RTSB	Input	Request to send
23	TxD	Input	Input transmit data, transmit HART data stream from microcontroller
24	RESETB	Open Drain	Reset all digital logic when low
25	RxD	Output	Received demodulated HART data to microcontroller
26	CD	Output	Carrier detect output
27	RxD_ENH	Output	not[CD] or RxD
28	DACREF	Input	Sigma-Delta Modulator Reference Voltage
29	DAC	Output	Sigma-Delta Modulator Output
30	VDD	Power	Digital supply voltage
31	CLK1	Output	Programmable Clock Output 1
32	CLK2	Output	Programmable Clock Output 2
EP	Exposed Pad	Power	Connect to VSS

Pin Descriptions

Table 8. PIN DESCRIPTIONS

Symbol	Pin Name	Description
AREF	Analog reference voltage	Receiver Reference Voltage. Normally 1.23 V is selected (in combination with VDDA = 3.3 V). See Table 2.
CDREF	Carrier detect reference voltage	Carrier Detect Reference voltage. The value should be 85 mV below AREF to set the carrier detection to a nominal of 100 mV <sub>p-p</sub> .
RESETB	Reset digital logic	When at logic low (V <sub>SS</sub> ) this input holds all the digital logic in reset. During normal operation RESETB should be at V <sub>DD</sub> .
RTSB	Request to send	Active-low input selects the operation of the modulator. TxA is enabled when this signal is low. This signal must be held high during power-up.
RxA	Analog receive input	Receive Data Demodulator Input. Accepts a HART 1200 / 2200 Hz FSK modulated waveform as input.
RxAFI	Analog receive comparator input	Positive input of the carrier detect comparator and the receiver filter comparator.
TxD	Digital transmit input	Input to the modulator accepts digital data in NRZ form. When TxD is low, the modulator output frequency is 2200 Hz. When TxD is high, the modulator output frequency is 1200 Hz.
XIN	Oscillator input	Input to the internal oscillator must be connected to a parallel mode ceramic resonator when using the internal oscillator or grounded when using an external clock signal.
XOUT	Oscillator output	Output from the internal oscillator must be connected to an external clock signal or to a parallel mode ceramic resonator when using the internal oscillator.
CLK1	Programmable Clock Output	Output signal derived from oscillator output, frequency division set by internal register.
CLK2	Programmable Clock Output	Output signal derived from oscillator output, frequency division set by internal register. As this signal is also used internally, the division should be set so that the output frequency is 460.8 kHz
CBIAS	Comparator bias current	Connection to the external bias resistor. R <sub>BIAS</sub> should be selected such that AREF / R <sub>BIAS</sub> = 2.5 μA ± 5 %
CD	Carrier detect output	Output goes high when a valid input is recognized on RxA. If the received signal is greater than the threshold specified on CDREF for four cycles of the RxA signal, the valid input is recognized.
RxAF	Analog receive filter output	The output of the three pole high pass receive data filter
RxD	Digital receive output	Signal outputs the digital receive data. When the received signal (RxA) is 1200 Hz, RxD outputs logic high. When the received signal (RxA) is 2200 Hz, RxD outputs logic low. The HART receive data stream is only active if Carrier Detect (CD) is high.
RxD_ENH	Digital receive output, alternative	Not(OCD) or RXD
TxA	Analog transmit output	Transmit Data Modulator Output. A trapezoidal shaped waveform with a frequency of 1200 Hz or 2200 Hz corresponding to a data value of 1 or 0 respectively applied to TxD. TxA is active when RTSB is low. TxA equals 0.5 V when RTSB is high.
SCLK	SPI bus clock line	Serial communication clock line
DATA	SPI bus data line	Serial communication data line. Frames transmitted can either be 8 bit or 16 bit long.
CS	SPI bus chip select	Serial communication chip select line. Pulled high by microcontroller while a frame is transmitted.
JUMP	DAC Alarm value	When a problem is detected, such as a clock failure or the watchdog going off, the DAC will jump to VSS or DACREF, depending on whether this pin is connected to VSS or VDD respectively.
DACREF	DAC Reference	This is the high value of the output and can be connected to any voltage between AREF and VDD.
DAC	DAC Output	Output of a 16 bit Sigma-Delta Modulator
KICK	Watchdog Kick	Periodically a pulse should be provided to reset the watchdog. This can be configured in internal registers for an internal 1.8kHz signal, or to an external signal provided to this pin.
VPOR	POR Input	Input to the POR comparator. The voltage on this pin is compared with AREF. An external resistor divider should divide the supply voltage to this pin.
VDD	Digital power	Power for the digital modem circuitry
VDDA	Analog supply voltage	Power for the analog modem circuitry
VSS	Ground	Digital ground
VSSA	Analog ground	Analog ground

**Functional Description**

The NCN5192 is a single-chip modem for use in Highway Addressable Remote Transducer (HART) field instruments and masters. The modem IC contains a transmit data modulator with signal shaper, carrier detect circuitry, an analog receiver, demodulator circuitry and an oscillator, as shown in the block diagram in Figure 1.

The modulator accepts digital data at its digital input TxD and generates a trapezoidal shaped FSK modulated signal at the analog output TxA. A digital “1” or mark is represented with a frequency of 1200 Hz. A digital “0” or space is represented with a frequency of 2200 Hz. The used bit rate is 1200 baud.

The demodulator receives the FSK signal at its analog input, filters it with a band-pass filter and generates 2 digital signals: RxD: Received Data and CD: Carrier Detect. At the digital output RxD the original modulated signal is received. CD outputs the Carrier Detect signal. It goes logic high if the received signal is above 100 mVpp during 4 consecutive carrier periods.

The oscillator provides the modem with a stable time base using either a simple external resonator or an external clock source.

**Detailed Description**

**Modulator**

The modulator accepts digital data in NRZ form at the TxD input and generates the FSK modulated signal at the TxA output.

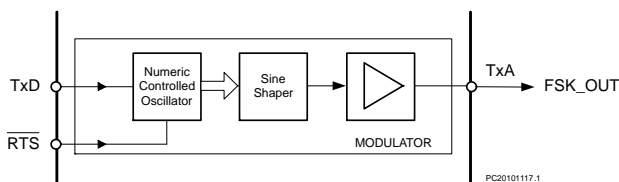

**Figure 4. Modulator Block Diagram**

A logic “1” or mark is represented by a frequency  $f_m = 1200$  Hz. A logic “0” or space is represented by a frequency  $f_s = 2200$  Hz.

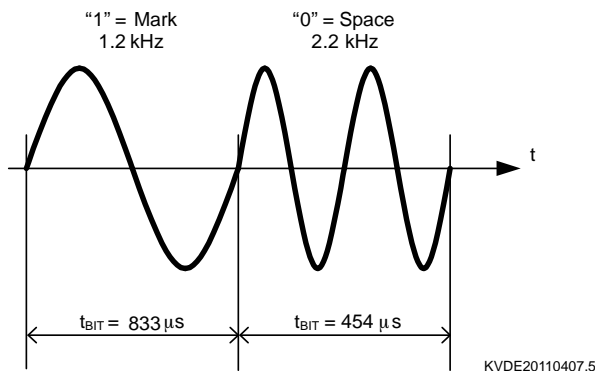

**Figure 5. Modulation Timing**

The Numeric Controlled Oscillator (NCO) works in a phase continuous mode preventing abrupt phase shifts when switching between mark and space frequency. The control signal “Request To Send” (RTSB) enables the NCO. When RTSB is logic low the modulator is active and NCN5192 is in transmit mode. When RTSB is logic high the modulator is disabled and NCN5192 is in receive mode.

The digital outputs of the NCO are shaped in the Wave Shaper block to a trapezoidal signal. This circuit controls the rising and falling edge to be inside the standard HART waveshape limits. Figure 6 shows the transmit-signal forms captured at TxA for mark and space frequency. The slew rates are  $SR_m = 1860$  V/s at the mark frequency and  $SR_s = 3300$  V/s at the space frequency. For  $A_{REF} = 1.235$  V, TxA will have a voltage swing from approximately 0.25 to  $0.75 V_{DC}$ .

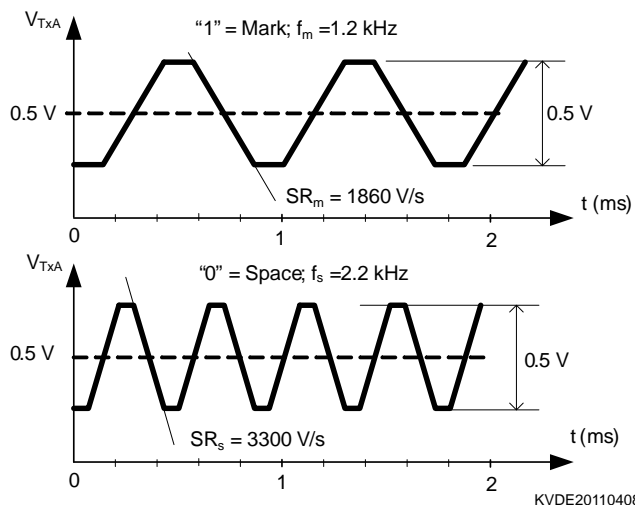

**Figure 6. Modulator shaped output signal for Mark and Space frequency at TxA pin.**

**Demodulator**

The demodulator accepts a FSK signal at the RxA input and reconstructs the original modulated signal at the RxD output. Figure 7 illustrates the demodulation process.

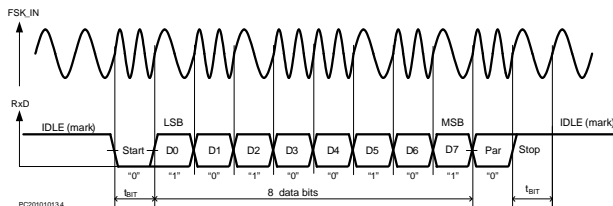
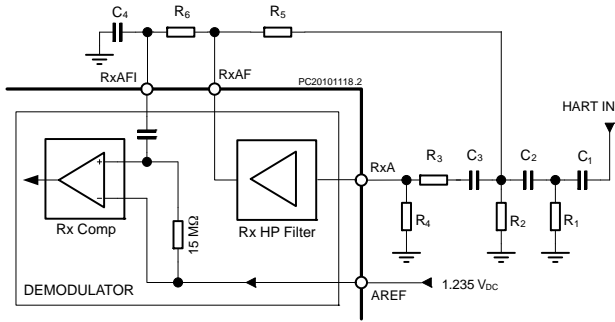

**Figure 7. Modulation Timing**

This HART bit stream follows a standard 11-bit UART frame with Start, Stop, 8 Data – and 1 Parity bit (odd). The communication speed is 1200 baud.

**Receive Filter and Comparator**

The received FSK signal first is filtered using a band-pass filter build around the low noise receiver operational amplifier “Rx HP filter”. This filter blocks interferences outside the HART signal band.



**Figure 8. Demodulator Receive Filter and Signal Comparator**

The filter output is fed into the Rx comparator. The threshold value equals the analog ground making the comparator to toggle on every zero crossing of the filtered FSK signal. The maximum demodulator jitter is 12 % of one bit given the input frequencies are within the HART specifications, a clock frequency of 460.8 kHz (±1.0 %) and zero input (RxA) asymmetry.

**Carrier Detect Circuitry**

Low HART input signal levels increases the risk for the generation of bit errors. Therefore the minimum signal amplitude is set to 80–120 mV<sub>pp</sub>. If the received signal is below this level the demodulator is disabled.

This level detection is done in the Carrier Detector. The output of the demodulator is qualified with the carrier detect signal (CD), therefore, only RxA signals large enough to be detected (100 mV<sub>p-p</sub> typically) by the carrier detect circuit produce received serial data at RxD.

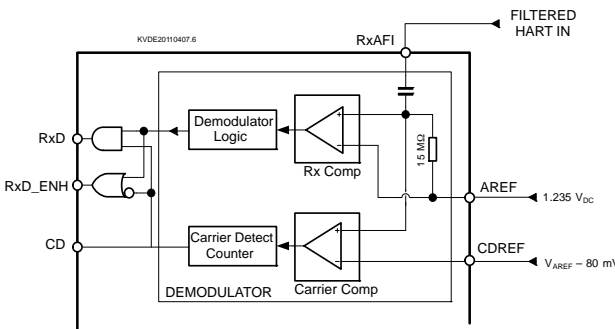

**Figure 9. Demodulator Carrier and Signal Comparator**

The carrier detect comparator shown in Figure 9 generates logic low output if the RxAFI voltage is below CDREF. The comparator output is fed into a carrier detect block. The carrier detect block drives the carrier detect output pin CD high if RTSB is high and four consecutive pulses out of the comparator have arrived. CD stays high as long as RTSB is

high and the next comparator pulse is received in less than 2.5 ms. Once CD goes inactive, it takes four consecutive pulses out of the comparator to assert CD again. Four consecutive pulses amount to 3.33 ms when the received signal is 1200 Hz and to 1.82 ms when the received signal is 2200 HZ. The difference between RxD and RxD\_ENH is evident when CD is low: RxD is then also low, while RxD\_ENH is then high. When CD is high, RxD and RxD\_ENH have the same output.

**Miscellaneous Analog Circuitry**

**Voltage References**

The NCN5192 requires two voltage references, AREF and CDREF. AREF sets the DC operating point of the internal operational amplifiers and is the reference for the Rx comparator. If NCN5192 operates at V<sub>DD</sub> = 3.3 V the ON Semiconductor LM285D 1.235 V reference is recommended.

The level at which CD (Carrier Detect) becomes active is determined by the DC voltage difference (CDREF - AREF). Selecting a voltage difference of 80 mV will set the carrier detect to a nominal 100 mV<sub>p-p</sub>.

**Bias Current Resistor**

The NCN5192 requires a bias current resistor R<sub>BIAS</sub> to be connected between CBIAS and V<sub>SS</sub>. The bias current controls the operating parameters of the internal operational amplifiers and comparators and should be set to 2.5 μA.

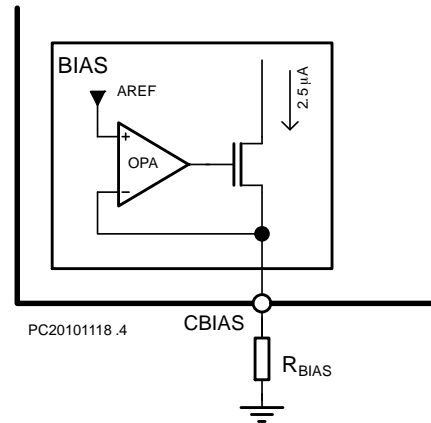

**Figure 10. Bias Circuit**

The value of the bias current resistor is determined by the reference voltage AREF and the following formula:

$$R_{BIAS} = \frac{AREF}{2.5 \mu A}$$

The recommended bias current resistor is 500 KΩ when AREF is equal to 1.235 V.

**Oscillator**

The clock signal used by NCN5192 can either be 460.8 kHz, 921.6 kHz or 1.8432 MHz. This can be provided by an external clock or a resonator or crystal connected to the internal oscillator.

**Internal Oscillator Option**

The oscillator cell will function with a 460.8 kHz, 921.6 kHz or 1.8432 MHz crystal or ceramic resonator. A parallel resonant ceramic resonator can be connected between XIN and XOUT. Figure 11 illustrates the crystal option for clock generation using a 460.8 kHz ( $\pm 1\%$  tolerance) parallel resonant crystal and two tuning capacitors  $C_x$ . The actual values of the capacitors may depend on the recommendations of the manufacturer of the resonator. Typically, capacitors in the range of 100 pF to 470 pF are used. Additionally, a resistor may be required between XOUT and the crystal terminal, depending on manufacturer recommendation.

The NCN5192 IC uses CLK2 as clock signal for the wave shaping and digital logic. This signal must be set 460.8 kHz by activating the proper frequency division in the internal register (bit 1 and 2). The CLK1 frequency division (bit 3 and 4) can be freely chosen. This programmable clock signal can be used to drive other ICs such as a microcontroller and is not used internally in the NCN5192.

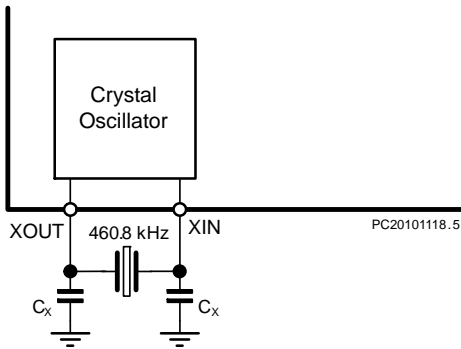

Figure 11. Crystal Oscillator

**External Clock Option**

It may be desirable to use an external clock as shown in Figure 12 rather than the internal oscillator. In addition, the NCN5192 consumes less current when an external clock is used. Minimum current consumption occurs with the clock connected to XOUT and XIN connected to  $V_{SS}$ .

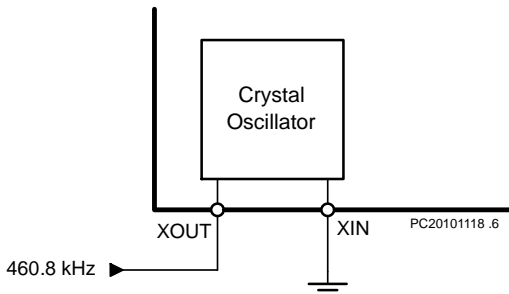

Figure 12. Oscillator with External Clock

**Reset**

The NCN5192 modem includes a Power on Reset block. An external resistor division of the supply voltage is required, and should be tied to pin VPOR. This pin is attached to an internal comparator, and is compared to the AREF voltage. When this comparator trips, the RESETB pin will be pulled low and the IC will reset. After VPOR returns to a valid level, the RESETB pin will be held low for at least an additional 35 ms (may be longer depending on clock frequency). The RESETB pin will also be pulled low when a microcontroller failure is detected. A watchdog will guard microcontroller communication by looking at the KICK pin. When the microcontroller fails to provide a periodical pulse on this pin, the watchdog will pull down the RESETB pin for 140  $\mu s$ . A rising edge should be provided to the IC at least every 53 ms. A 1.8 kHz kick can also be provided internally if bit 5 of the internal register is set. If the watchdog kick is provided internally, the KICK pin should be tied to  $V_{SS}$ .

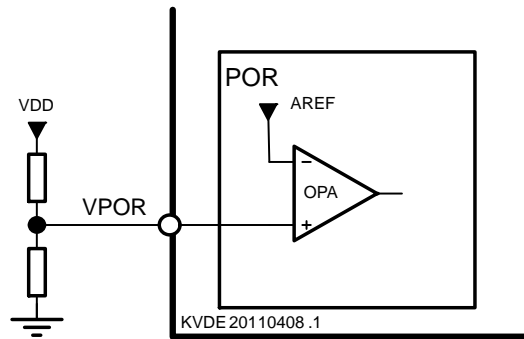

Figure 13. Power on Reset Block

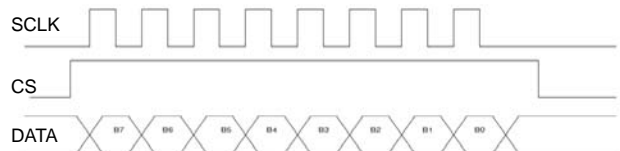

Figure 14. 8 Bit SPI Frame

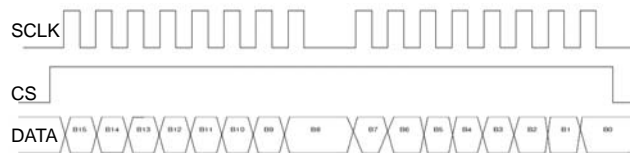

Figure 15. 16 Bit SPI Frame

**SPI Communication**

The SPI bus on the NCN5192 is made up of three signals; DATA, SCLK, and CS. The data is either 8 bits or 16 bits. In the case of 8 bits CS will go high for eight clock cycles of SCLK and in the case of 16 bits CS will be high for 16 clock cycles of SCLK, as can be seen on Figures 14 and 15.

CS should first go high at least one clock cycle before the other signals change. One clock cycle is 2.17  $\mu s$  at a master

clock frequency of 460.8 kHz. CS is clocked in at the falling edge of the CLK1 clock to detect if the data is for the mode register or the DAC.

SCLK can begin to clock in DATA serially to the chip on the falling edge of SCLK. SCLK should have a maximum frequency of 460.8 kHz. The format of the data should be either 8 or 16 bits with the most significant bit first.

DATA is shifted into the chip on the falling edge of SCLK, and thus for correct operation DATA should change only on the rising edge of SCLK. The first bit shifted in is the MSB. If 14 bit DAC communication is utilized, then two 0's should precede the 14 bits, and 16 clock cycles on SCLK should occur. Once the data is shifted in, CS should go low no sooner than one clock cycle after the last rising edge of SCLK.

**Table 9. INTERNAL REGISTER DESCRIPTION**

Bit	Description
0 (LSB)	0 = DAC in 14-bit mode 1 = DAC in 16-bit mode
1	Set the crystal divide so that CLK2 is 460.8 kHz Bit 2    Bit 1
2	0      0      Crystal/2
	0      1      Crystal/4
	1      0      Crystal/1
3	1      1      Crystal/4
	Set the crystal divide for CLK1 Bit 4    Bit 3
	0      0      Crystal/2
4	0      1      Crystal/4
	1      0      Crystal/1
	1      1      Crystal/4
5	0 = Watchdog kick external (pin) 1 = Watchdog kick internal (1.8 kHz)
6	0 = RTZ output format on DAC 1 = Non RTZ output format on DAC
7 (MSB)	0 = RxD is low when carrier is off 1 = RxD is high when carrier is off  Setting this bit, changes the function of RxD to the function of RxD_ENH

**Table 10. SPI FRAME FORMAT**

Description	Bits	15	14	13	12	11	10	9	8	7	6	5	4	3	2	1	0
Mode Register	8									Mode Register Data							
DAC – 14 bits mode	16	0	0	DAC Output Word													
DAC – 16 bits mode	16	DAC Output Word															

**Internal Register**

The NCN5192 has an 8 bit register to setup its internal operation. An 8 bit SPI communication method is used to write to the mode register. If CS goes low after only 8 clock cycles of SCLK the Mode register will latch in the 8 bits which are shifted into the SPI shift register. In Table 9 an explanation of the usage of each bit is given. All bits are set to '0' at reset.

**Sigma Delta DAC**

The NCN5192 Modem has an integrated Sigma-Delta Modulator for use in a current loop slave transmitter. Through this DAC, an analog value can be set and transmitted across the current loop. For more information on how to create a current loop slave transmitter, see application notes on the ON Semi website. The DAC output will switch between 0 V and the voltage provided to DACREF. To achieve maximum accuracy, the DACREF voltage should be kept stable, so that power supply variations are not visible in the DAC output. The Sigma-Delta modulator output can be set through SPI frames containing 14 or 16 significant bits. The length of the data frames can be set through bit 0 is the status register. The output of the DAC can be set return to zero (RTZ) or non-RTZ. This is important when the rise and fall time of the signal are not identical. This will cause a DC offset depending on the number of rising and falling edges. As the output bits of a sigma-delta modulator are randomly arranged (ie. for the same setting we could get 01110000 or 01010100), the number of edges might vary over time for a non return to zero signal. Setting the DAC to "return to zero" forces the output to have a rising and falling edge for each logic "1" bit, so that no offset from pulse asymmetry can occur. However, this will decrease the range of the modulator to 50% of DACREF, as the maximum duty cycle is 50% instead of 100% for NRZ. When a clock failure is detected, using an internal oscillator, the DAC output will jump to the level set by the JUMP pin, until the IC is reset or a rising flank is detected on KICK.

## NCN5192

### Ordering Information

The NCN5192 is available in a 32-pin no lead quad flat pack (NQFP). Use the following part numbers when ordering. Contact your local sales representative for more information: [www.onsemi.com](http://www.onsemi.com).

**Table 11. ORDERING INFORMATION**

Part Number	Package	Shipping Configuration	Temperature Range
NCN5192MNG	32-pin NQFP Green/RoHS compliant	60 Tube/Tray	-40°C to +85°C (Industrial)
NCN5192MNRG	32-pin NQFP Green/RoHS compliant	5000 / Tape & Reel	-40°C to +85°C (Industrial)

# MECHANICAL CASE OUTLINE

## PACKAGE DIMENSIONS

ON Semiconductor®

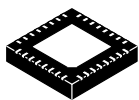

1 32

SCALE 2:1

QFN32 5x5, 0.5P  
CASE 488AM  
ISSUE A

DATE 23 OCT 2013

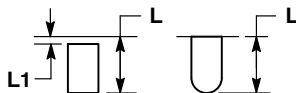
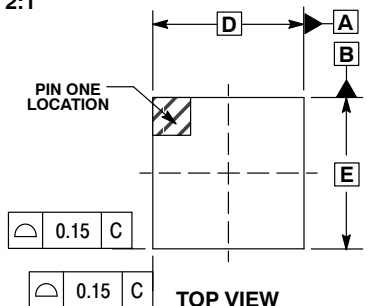

DETAIL A  
ALTERNATE TERMINAL  
CONSTRUCTIONS

NOTES:

1. DIMENSIONS AND TOLERANCING PER ASME Y14.5M, 1994.
2. CONTROLLING DIMENSION: MILLIMETERS.
3. DIMENSION b APPLIES TO PLATED TERMINAL AND IS MEASURED BETWEEN 0.15 AND 0.30MM FROM THE TERMINAL TIP. COPLANARITY APPLIES TO THE EXPOSED PAD AS WELL AS THE TERMINALS.
4. COPLANARITY APPLIES TO THE EXPOSED PAD AS WELL AS THE TERMINALS.

MILLIMETERS		
DIM	MIN	MAX
A	0.80	1.00
A1	---	0.05
A3	0.20	REF
b	0.18	0.30
D	5.00	BSC
D2	2.95	3.25
E	5.00	BSC
E2	2.95	3.25
e	0.50	BSC
K	0.20	---
L	0.30	0.50
L1	---	0.15

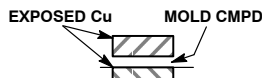
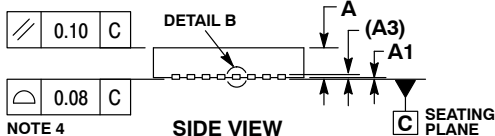

DETAIL B  
ALTERNATE  
CONSTRUCTION

GENERIC  
MARKING DIAGRAM\*

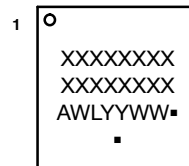
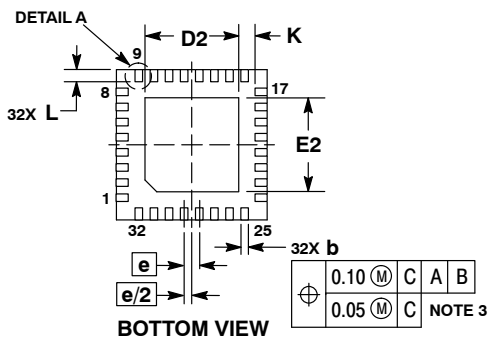

- XXXXX = Specific Device Code
- A = Assembly Location
- WL = Wafer Lot
- YY = Year
- WW = Work Week
- = Pb-Free Package

(Note: Microdot may be in either location)  
\*This information is generic. Please refer to device data sheet for actual part marking.  
Pb-Free indicator, "G" or microdot "▪", may or may not be present.

RECOMMENDED  
SOLDERING FOOTPRINT\*

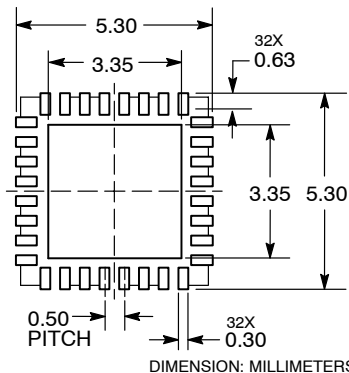

\*For additional information on our Pb-Free strategy and soldering details, please download the ON Semiconductor Soldering and Mounting Techniques Reference Manual, SOLDERRM/D.

DOCUMENT NUMBER:	98AON20032D	Electronic versions are uncontrolled except when accessed directly from the Document Repository. Printed versions are uncontrolled except when stamped "CONTROLLED COPY" in red.
DESCRIPTION:	QFN32 5x5 0.5P	PAGE 1 OF 1

ON Semiconductor and ON are trademarks of Semiconductor Components Industries, LLC dba ON Semiconductor or its subsidiaries in the United States and/or other countries. ON Semiconductor reserves the right to make changes without further notice to any products herein. ON Semiconductor makes no warranty, representation or guarantee regarding the suitability of its products for any particular purpose, nor does ON Semiconductor assume any liability arising out of the application or use of any product or circuit, and specifically disclaims any and all liability, including without limitation special, consequential or incidental damages. ON Semiconductor does not convey any license under its patent rights nor the rights of others.

**onsemi**, **Onsemi**, and other names, marks, and brands are registered and/or common law trademarks of Semiconductor Components Industries, LLC dba "**onsemi**" or its affiliates and/or subsidiaries in the United States and/or other countries. **onsemi** owns the rights to a number of patents, trademarks, copyrights, trade secrets, and other intellectual property. A listing of **onsemi**'s product/patent coverage may be accessed at [www.onsemi.com/site/pdf/Patent-Marking.pdf](http://www.onsemi.com/site/pdf/Patent-Marking.pdf). **onsemi** reserves the right to make changes at any time to any products or information herein, without notice. The information herein is provided "as-is" and **onsemi** makes no warranty, representation or guarantee regarding the accuracy of the information, product features, availability, functionality, or suitability of its products for any particular purpose, nor does **onsemi** assume any liability arising out of the application or use of any product or circuit, and specifically disclaims any and all liability, including without limitation special, consequential or incidental damages. Buyer is responsible for its products and applications using **onsemi** products, including compliance with all laws, regulations and safety requirements or standards, regardless of any support or applications information provided by **onsemi**. "Typical" parameters which may be provided in **onsemi** data sheets and/or specifications can and do vary in different applications and actual performance may vary over time. All operating parameters, including "Typicals" must be validated for each customer application by customer's technical experts. **onsemi** does not convey any license under any of its intellectual property rights nor the rights of others. **onsemi** products are not designed, intended, or authorized for use as a critical component in life support systems or any FDA Class 3 medical devices or medical devices with a same or similar classification in a foreign jurisdiction or any devices intended for implantation in the human body. Should Buyer purchase or use **onsemi** products for any such unintended or unauthorized application, Buyer shall indemnify and hold **onsemi** and its officers, employees, subsidiaries, affiliates, and distributors harmless against all claims, costs, damages, and expenses, and reasonable attorney fees arising out of, directly or indirectly, any claim of personal injury or death associated with such unintended or unauthorized use, even if such claim alleges that **onsemi** was negligent regarding the design or manufacture of the part. **onsemi** is an Equal Opportunity/Affirmative Action Employer. This literature is subject to all applicable copyright laws and is not for resale in any manner.

## ADDITIONAL INFORMATION

### TECHNICAL PUBLICATIONS:

Technical Library: [www.onsemi.com/design/resources/technical-documentation](http://www.onsemi.com/design/resources/technical-documentation)  
onsemi Website: [www.onsemi.com](http://www.onsemi.com)

### ONLINE SUPPORT: [www.onsemi.com/support](http://www.onsemi.com/support)

For additional information, please contact your local Sales Representative at [www.onsemi.com/support/sales](http://www.onsemi.com/support/sales)

## Looking for pricing, stock, or lifecycle information?

Click below to explore more details on WIN SOURCE:

 [View NCN5192MNRG on WIN SOURCE](#)

 [ON Semiconductor](#) Information

## Optimize Your Supply Chain with WIN SOURCE Solutions

-  Global Sourcing Solution
-  Obsolete Management
-  Cost Control Management
-  Shortage Management
-  Alternative Solution
-  Excess Inventory Management