



**THE DATASHEET OF
ZXF103Q16TC**



ZXF103

VARIABLE Q FILTER

ZXF103Q16, ZXF103EV

DESCRIPTION

The ZXF103 is a versatile analog high Q bandpass filter. It can be configured to provide pass or notch characteristics.

The basic filter section requires 2 resistors and 2 capacitors to set the centre frequency. The frequency range is up to 600kHz. Two external resistors control filter Q Factor. The Q can be varied up to 50.

APPLICATIONS

Many filter applications including: -

- Sonar and Ultrasonic Systems
- Line frequency notch
- Signalling
- Motion detection
- Instrumentation
- Low frequency telemetry

FEATURES AND BENEFITS

- Centre Frequency up to 1MHz
- Variable Q up to 50
- Low distortion
- Low noise
- Low power 25mW
- Devices easily cascaded
- Small QSOP16 package

ORDERING INFORMATION

PART NUMBER	PACKAGE	PART MARK
ZXF103Q16	QSOP16	ZXF103

PART NUMBER	CONTAINER	INCREMENT
ZXF103Q16TA	Reel 7" 178mm	500
ZXF103Q16TC	Reel 13" 330mm	2500

SYSTEM DIAGRAM

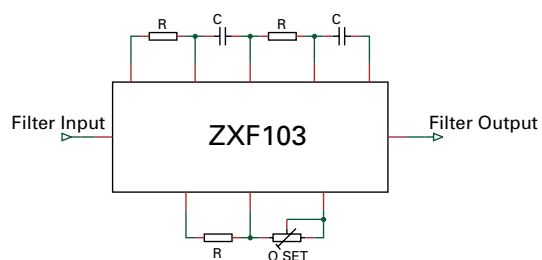

PINOUT

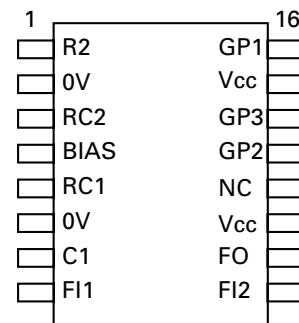

ZXF103

ABSOLUTE MAXIMUM RATINGS

Voltage on any pin	7.0V (relative to 0V)
Operating temperature range	0 to 70°C
Storage temperature	-55 to 125°C

ELECTRICAL CHARACTERISTICS Test Conditions: Temperature =25°C, V_{CC} = 5.00V, 0V =0.00V, R_L=10k,C_L=10pF

GENERAL CHARACTERISTICS					
Parameter	Conditions	Min.	Typical	Max.	Units
Operating current			4.0	5.0	mA
Max. operating frequency	V _{out} =1.6V p-p V _{out} =1.0V p-p			600 1000	kHz
Q usable range		0.5		50	
Centre Frequency temperature coefficient	Q=30, fo = 1kHz		100		ppm/°C
Q temperature coefficient	Q=30, fo = 1kHz		0.1		% /°C
Voltage noise	1 – 100 kHz		20		nV/√ Hz
Input impedance		10	15	20	kΩ
Linear Output Range	Output load =10 kΩ		2		V pk-pk
Sink current			450		μA
Source current			450		μA
Output impedance			10		Ω

**Histogram of Centre Frequency
(Fo = 11.80KHz Q = 25)**

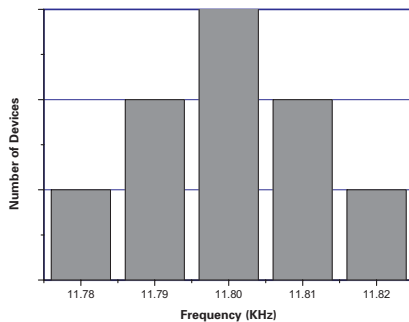

Pin	Name	Function
1	R2	Phase retard node
2	0V	0 Volts
3	RC2	Phase retard node
4	BIAS	Internal bias generator
5	RC1	Phase advance node
6	0V	0 Volts
7	C1	Phase advance node
8	FI1	Filter input mode dependent
9	FI2	Filter input, mode dependent
10	FO	Filter output for all modes
11	Vcc	+5 Volt supply
12	N/C	No connection
13	GP2	Loop gain node
14	GP3	Loop gain node
15	Vcc	+5 Volt supply
16	GP1	Loop gain node

ZXF103

Filter Configurations and Responses Notch Filter

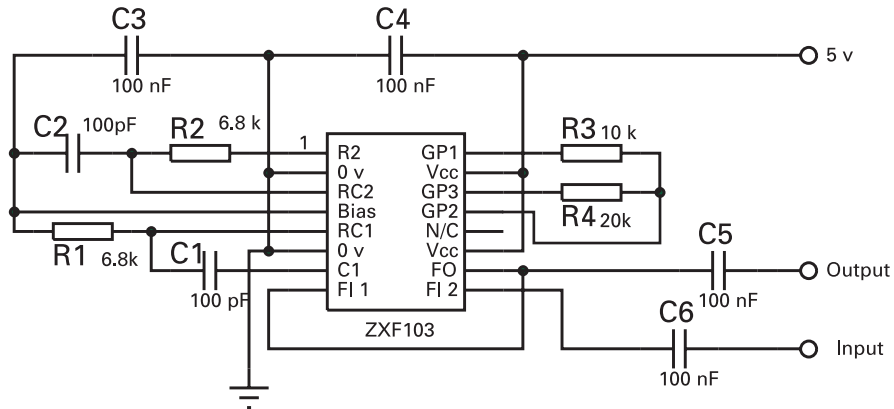

AC Filter Performance

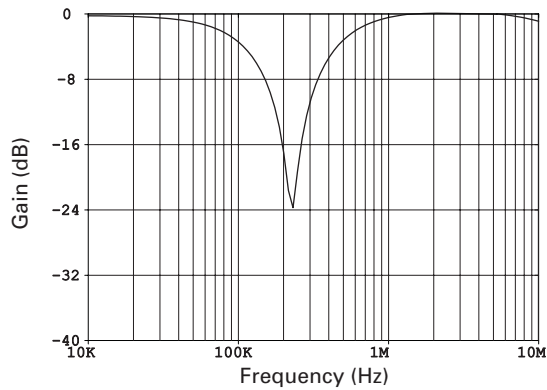

$$F_o = \frac{1}{2\pi RC}$$

where $R=R_1=R_2$
and $C=C_1=C_2$

$$Q \propto \frac{R_4}{R_3}$$

where R_1, R_2, R_3 and $R_4 \geq 2k\Omega$
and C_1 and $C_2 \geq 50pF$

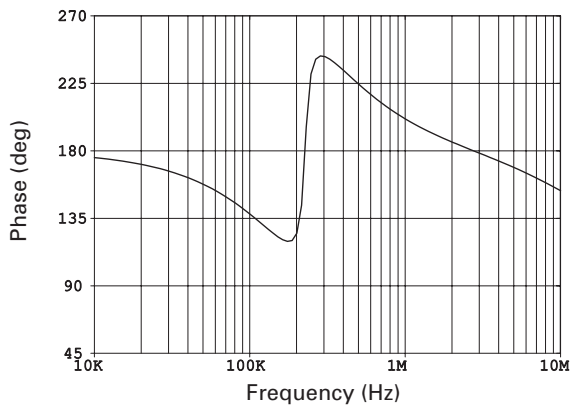

See "Designing for a value of Q"
for more details.

ZXF103

Filter Configurations and Responses (Continued) Inverse Notch Filter (with 0dB Stop Band)

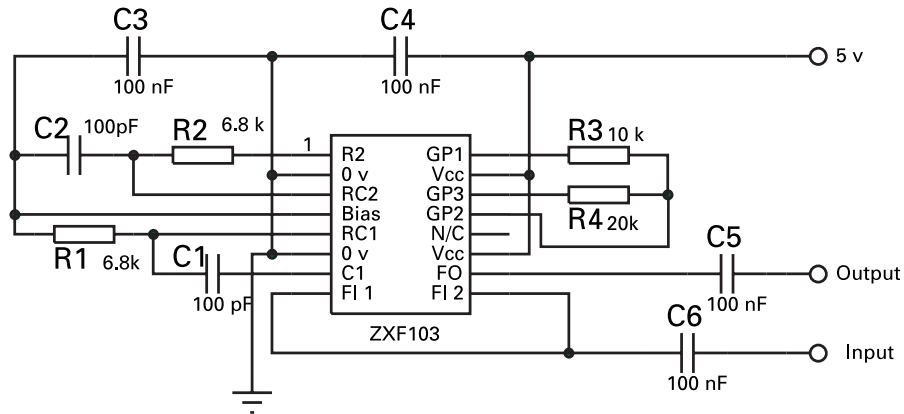

AC Filter Performance

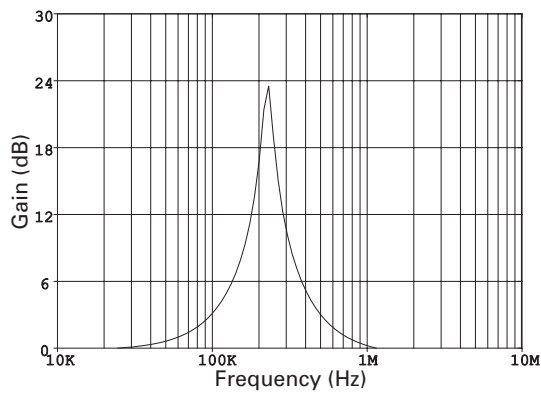

$$F_o = \frac{1}{2\pi RC}$$

where $R=R_1=R_2$
and $C=C_1=C_2$

$$Q \propto \frac{R_4}{R_3}$$

where R_1, R_2, R_3 and $R_4 \geq 2k\Omega$
and C_1 and $C_2 \geq 50pF$

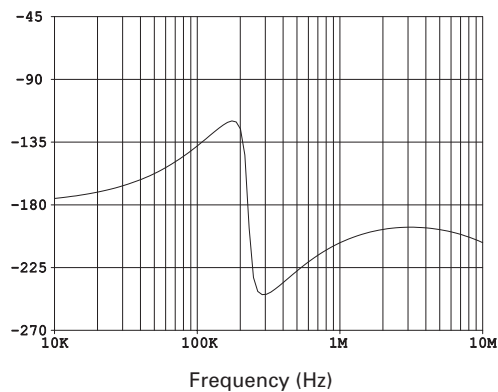

ZXF103

Filter Configurations and Responses (Continued) Inverse Notch Filter (with attenuating skirts)

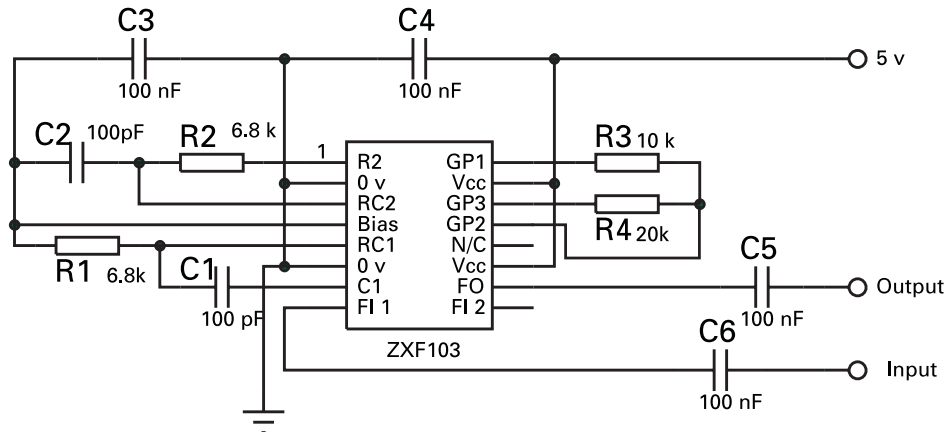

AC Filter Performance

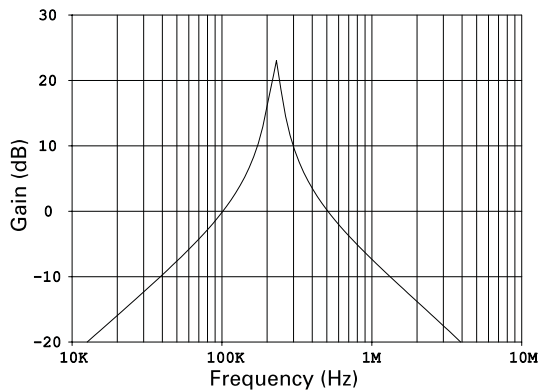

$$F_o = \frac{1}{2\pi RC}$$

where $R=R_1=R_2$
and $C=C_1=C_2$

$$Q \propto \frac{R_4}{R_3}$$

where R_1, R_2, R_3 and $R_4 \geq 2k\Omega$
and C_1 and $C_2 \geq 50pF$

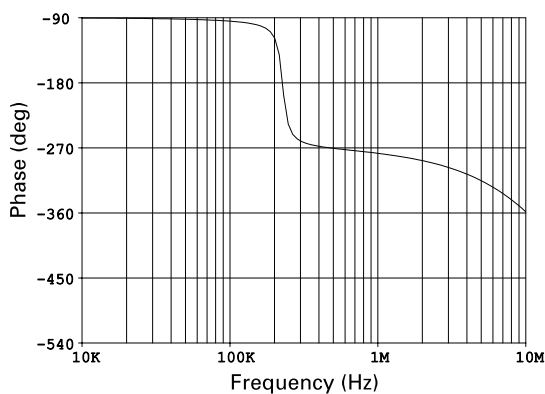

See "Designing for a value of Q"
for more details.

The skirt 'roll off' away from the
peak is -20dB/Decade regardless
of chosen Q.

Typical responses from the circuit
with component values derived
from the diagram.

ZXF103

Designing for a value of Q

As mentioned on the configuration pages, there is a proportional relationship between the ratio of R4 and R3, and Q.

$$Q \propto \frac{R4}{R3}$$

These resistors define the gain of an inverting amplifier that determines the peak value of gain and therefore the Q of the filter, as Q is described as;

$$Q = \frac{F_o}{-3dB\text{Bandwidth}}$$

This value of required gain is quite critical. As the maximum value of Q is approached, too much gain will cause the filter to oscillate at the centre frequency Fo. A small reduction of gain will cause the value of Q to fall significantly. Therefore, for high values of Q factor or tight tolerances of lower values of Q, the resistor ratio must be trimmed.

Frequency dependant effects must be accounted for in determining the appropriate gain. As the frequency increases, the effective circuit gain reduces. The required gain is nominally two but at higher frequencies it will need to be slightly greater than two in order to compensate for loss of gain and internal phase shifts.

This is not really a problem for circuits where the desired Fo remains constant, as the phase shifts are accounted for permanently. For designs where Q is high and Fo is to be 'swept', care must be taken that a gain appropriate at the highest frequency does not cause oscillation at the lowest.

Variation in Q increases from device to device, as the value of Q increases, due to internal gain spreads.

Typical Gain at Fo V Q Factor (Fo = 140KHz)

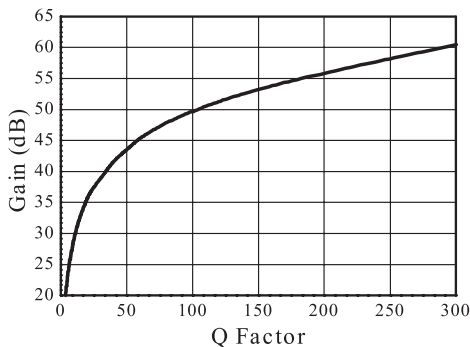

Q Factor V Temperature

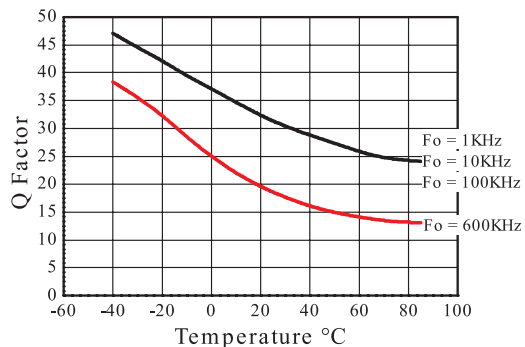

ZXF103

EVALUATION BOARD

An evaluation board (ZXF103EV) is available to assist with in-system or stand-alone performance evaluation. The board can be set, by simple jumper links, to perform any of the filter characteristics responses.

Evaluation boards can be purchased from our catalogue distributors.

Digi-Key North America www.digikey.com
Tel: 1-800344-4539

Europe - Farnell www.farnell.com
Tel: 44-113-263-6311



Evaluation Board Schematic

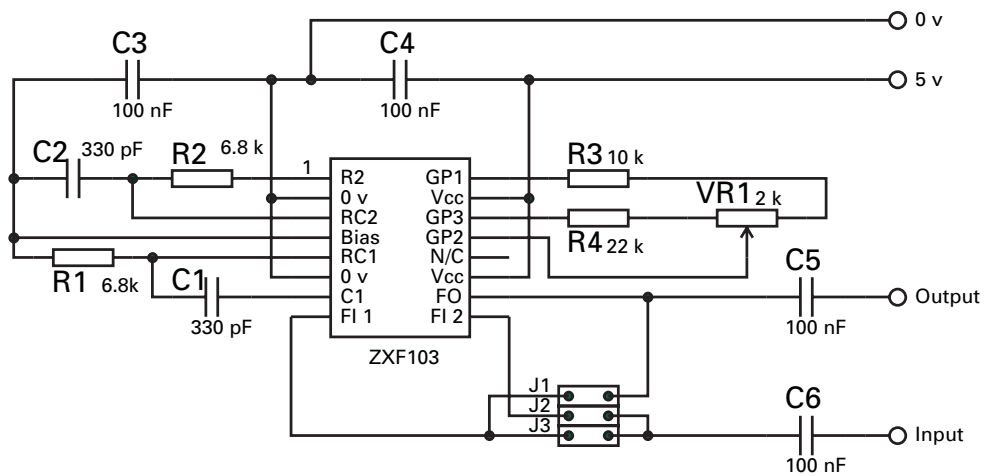

The evaluation board is designed for operation at 70kHz.

Notch	J1 and J2
Notch Pass 1	J2 and J3 (0dB Stop Band)
Notch Pass 2	J3 only (Attenuating skirts)

ZXF103

QSOP16 PACKAGE OUTLINE

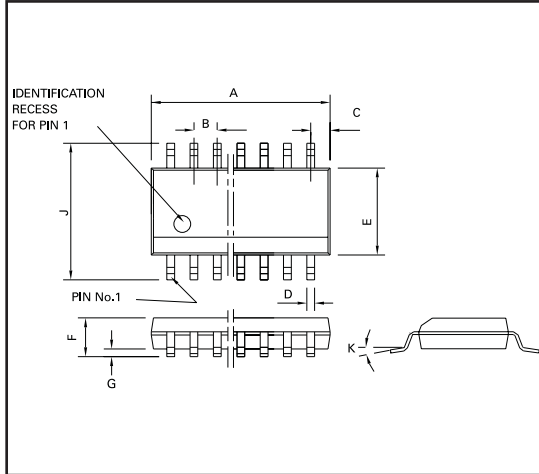

Conforms to JEDEC MO-137AB Iss A

QSOP16 PACKAGE DIMENSIONS

DIM	Millimetres		Inches	
	MIN	MAX	MIN	MAX
A	4.80	4.98	0.189	0.196
B	0.635		0.025 NOM	
C	0.23 REF		0.009 REF	
D	0.20	0.30	0.008	0.012
E	3.81	3.99	0.15	0.157
F	1.35	1.75	0.053	0.069
G	0.10	0.25	0.004	0.01
J	5.79	6.20	0.228	0.244
K	0°	8°	0°	8°

© Zetex plc 2002

Europe

Zetex plc
Fields New Road
Chadderton
Oldham, OL9 8NP
United Kingdom
Telephone: (44) 161 622 4422
Fax: (44) 161 622 4420
uk.sales@zetex.com

Zetex GmbH
Streitfeldstraße 19
D-81673 München
Germany
Telefon: (49) 89 45 49 49 0
Fax: (49) 89 45 49 49 49
europe.sales@zetex.com

Americas

Zetex Inc
700 Veterans Memorial Hwy
Hauppauge, NY11788
USA
Telephone: (631) 360 2222
Fax: (631) 360 8222
usa.sales@zetex.com

Asia Pacific

Zetex (Asia) Ltd
3701-04 Metroplaza, Tower 1
Hing Fong Road
Kwai Fong
Hong Kong
Telephone: (852) 26100 611
Fax: (852) 24250 494
asia.sales@zetex.com

These offices are supported by agents and distributors in major countries world-wide.



This publication is issued to provide outline information only which (unless agreed by the Company in writing) may not be used, applied or reproduced for any purpose or form part of any order or contract or be regarded as a representation relating to the products or services concerned. The Company reserves the right to alter without notice the specification, design, price or conditions of supply of any product or service.

For the latest product information, log on to www.zetex.com

ISSUE 2 - JULY 2002

Looking for pricing, stock, or lifecycle information?

Click below to explore more details on WIN SOURCE:

-  [View ZXF103Q16TC on WIN SOURCE](#)
-  [Diodes Incorporated Information](#)

Optimize Your Supply Chain with WIN SOURCE Solutions

-  Global Sourcing Solution
-  Obsolete Management
-  Cost Control Management
-  Shortage Management
-  Alternative Solution
-  Excess Inventory Management