



**THE DATASHEET OF  
ADP8140ACPZ-2-R7**



## FEATURES

- Highly integrated feature set for a high brightness LED driver solution with minimal external components
- 4 current sink channels with an adjustable current from 125  $\mu$ A to 500 mA
- Analog and pulse-width modulation (PWM) dimming inputs
- Analog and PWM LED current outputs
- 2% (maximum) matching between LED channels
- 5% (maximum) LED current accuracy
- Operates from  $V_{IN}$  of 3 V to 30 V; higher voltages easily accomplished with an external Zener diode
- Operates with LED anode supply voltages up to 100 V dc
- Feedback output controls external power source for optimal efficiency and safety
- Multiple **ADP8140** IC operation in parallel to control one power supply
- Integrated error amplifier for secondary side control of isolated power supplies
- Easy connection of a temperature thermistor or light sensor
- Provides robust protection of the entire system
  - Power supply overvoltage protection
  - LED overtemperature protection
  - LED short-circuit protection
  - LED open-circuit protection
  - IC overtemperature protection
  - Shorted ISET protection
  - Open ISET and EN protection
- Standby mode for low current consumption
- Fault indicator output
- Small, thermally enhanced, LFCSP package (4 mm  $\times$  4 mm)

## APPLICATIONS

- High brightness LED lighting
- Large format LED backlighting

## GENERAL DESCRIPTION

The **ADP8140** provides high current control of up to four LED drivers. Each driver can sink up to 500 mA. The sink current is programmed for all four drivers with one external resistor.

The device features a feedback output that controls an external power supply for optimal efficiency. The **ADP8140** also protects the LEDs, power supply, and itself against thermal events, short

Rev. B

[Document Feedback](#)

Information furnished by Analog Devices is believed to be accurate and reliable. However, no responsibility is assumed by Analog Devices for its use, nor for any infringements of patents or other rights of third parties that may result from its use. Specifications subject to change without notice. No license is granted by implication or otherwise under any patent or patent rights of Analog Devices. Trademarks and registered trademarks are the property of their respective owners.

## TYPICAL APPLICATION CIRCUITS

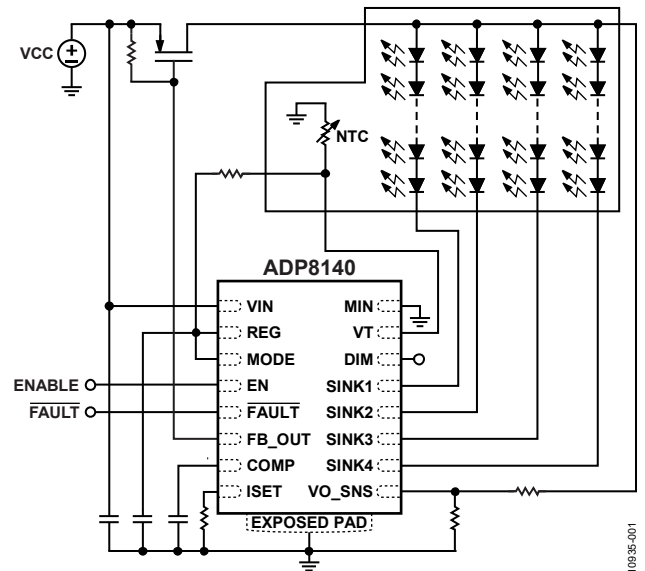
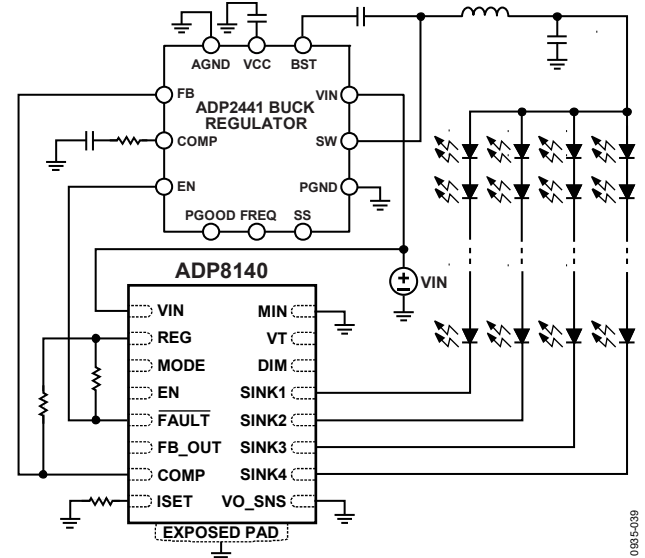
 Figure 1. **ADP8140** Used with Shunt Regulator

 Figure 2. **ADP8140** Used with Buck

circuits, overvoltages, and LED open circuits. Multiple **ADP8140** ICs are easily connected in parallel to drive additional LED strings or higher current LEDs. The **ADP8140** is available in a small, thermally enhanced, lead frame chip scale package (LFCSP).

## TABLE OF CONTENTS

Features .....	1	MODE Pin Operation.....	13
Applications.....	1	Power Control Modes.....	13
Typical Application Circuits.....	1	Dimming the LED Current.....	14
General Description .....	1	Reducing the LED Current with the DIM Pin .....	15
Revision History .....	2	Dimming LEDs with the VT Pin .....	15
Specifications.....	3	Fault Protections.....	15
Absolute Maximum Ratings.....	6	LED Open-Circuit and Short-Circuit Protection .....	16
Maximum Temperature Ranges .....	6	Die Temperature Protection .....	17
Thermal Resistance .....	6	Using Multiple ADP8140 ICs .....	17
ESD Caution.....	6	Operating the ADP8140 from Higher Input Voltages .....	18
Pin Configuration and Function Descriptions.....	7	Effect of LED $V_F$ Mismatch.....	18
Typical Performance Characteristics .....	8	Managing the Power Dissipation of the ADP8140 .....	19
Theory of Operation .....	11	Layout Guidelines.....	19
Start-Up Sequence.....	11	Ordering Options.....	19
Current Sinks .....	12	Outline Dimensions .....	23
Power Control Operation.....	12	Ordering Guide .....	23

## REVISION HISTORY

### 9/2020—Rev. A to Rev. B

Changes to Figure 36.....	22
---------------------------	----

### 9/2018—Rev. 0 to Rev. A

Updated Outline Dimensions .....	23
Changes to Ordering Guide .....	23

### 2/2015—Revision 0: Initial Version

## SPECIFICATIONS

VIN = 12 V, EN = DIM = VT = 3.0 V, MIN = MODE = 0 V. Typical values are at Tj = 25°C and are not guaranteed. Minimum and maximum limits are guaranteed from Tj = -40°C to +125°C, unless otherwise noted.

Table 1.

Parameter	Symbol	Test Conditions/Comments	Min	Typ	Max	Unit
<b>SUPPLY</b>						
Input Voltage						
Operating Range	V <sub>IN</sub>		3.0		30.0	V
Undervoltage Lockout	V <sub>UVLO</sub>			2.85	2.95	V
Quiescent Current						
During Standby	I <sub>Q(STBY)</sub>	EN = 0 V, VIN = 3.3 V to 30 V		200		μA
During Operation	I <sub>Q(ACTIVE)</sub>	EN = 3 V, VIN = 3.3 V to 30 V, R <sub>SET</sub> = 71.5 kΩ		4.1	4.5	mA
REG Output						
Output Voltage	V <sub>REG1</sub> V <sub>REG2</sub>	VIN = 3.3 V to 30 V, I <sub>REG</sub> = 1 mA VIN = 3 V, I <sub>REG</sub> = 1 mA	2.85 2.85	3.0 2.95	3.15	V V
Source Current	I <sub>REGMAX</sub>	VIN = 3.3 V to 30 V	15			mA
Load Regulation		VIN = 3.3 V to 30 V, I <sub>REG</sub> = 0.1 mA to 15 mA		0.75		mV/mA
<b>FEEDBACK OUTPUT</b>						
FB_OUT Error Amplifier (EA) Accuracy	V <sub>EA(450)</sub> V <sub>EA(350)</sub>		430 324	450 350	476 380	mV mV
FB_OUT NMOS Pull-Down Current	I <sub>FB_PD</sub>	SINKx = 0 V, FB_OUT = 3 V	12.0	15.0	18.0	mA
FB_OUT Stage Gain	G <sub>FB</sub>	Force 1.2 V and 1.3 V on COMP, measure FB_OUT current (FB_OUT = 12 V)	12500	17000	22000	μmho
FB_OUT Fault Current	I <sub>FB_FC</sub>	Fault activated, FB_OUT = 30 V		0.04	1	μA
Amplifier Transconductance	COMP <sub>GM</sub>		30	60	120	μmho
Amplifier Transconductance Output						
Source	COMP <sub>SOURCE</sub>	COMP pin output source current		110		μA
Sink	COMP <sub>SINK</sub>	COMP pin output sink current		1.5		mA
Resistance	COMP <sub>RO</sub>			20		MΩ
Low Gain EA	G <sub>BUFF</sub>	Gain in buffer mode (MODE = 30.1 kΩ to GND)	3.6	3.9	4.2	
Low Gain Bandwidth		MODE = 30.1 kΩ to GND		100		kHz
<b>ISET</b>						
Accuracy	I <sub>LED_500</sub> I <sub>LED_350</sub> I <sub>LED_100</sub> I <sub>LED_35</sub>	R <sub>SET</sub> = 5.11 kΩ, SINKx = 600 mV R <sub>SET</sub> = 7.32 kΩ, SINKx = 600 mV R <sub>SET</sub> = 25.5 kΩ, SINKx = 600 mV R <sub>SET</sub> = 71.5 kΩ, SINKx = 600 mV	475 332.5 95 33.0	500 350 100 35	525 367.5 105 37.5	mA mA mA mA
Shorted Current		ISET = GND	500	570	620	mA
Open Current		ISET = open		15	17	mA
<b>CURRENT SINKS</b>						
Current Sink Headroom Voltage at Maximum Current	V <sub>HR_500</sub> V <sub>HR_350</sub>	R <sub>SET</sub> = 5.11 kΩ, I <sub>LED</sub> = 95% × I <sub>LED_500</sub> R <sub>SET</sub> = 7.32 kΩ, I <sub>LED</sub> = 95% × I <sub>LED_350</sub>		320 210	430 324	mV mV
Current at 350 mV	I <sub>HR_350</sub>	Maximum guaranteed current using the 350 mV reference option	350			mA
Sink Matching		Matching = (I <sub>SINK_MAX</sub> - I <sub>SINK_MIN</sub> ) / (I <sub>SINK_MAX</sub> + I <sub>SINK_MIN</sub> ) × 100				
At 500 mA Current	I <sub>MATCH500</sub>			0.2	2	%
At 350 mA Current	I <sub>MATCH350</sub>			0.25	2	%
At 100 mA Current	I <sub>MATCH100</sub>			0.25	2	%
At 35 mA Current	I <sub>MATCH35</sub>			0.3	2	%

Parameter	Symbol	Test Conditions/Comments	Min	Typ	Max	Unit
SINKx Leakage Current	$I_{SINK(LKG)}$	SINKx pin = 4 V		8	12	$\mu A$
Channel Clamp Threshold Low	$V_{CH\_CLMP\_LOW}$	Threshold on SINKx to trigger $V_{CH\_CLMP\_LOW}$ , MIN pin = GND	7.4	7.75	8.1	V
Channel Clamp Threshold High	$V_{CH\_CLMP\_HIGH}$	Threshold on SINKx to trigger $V_{CH\_CLMP\_HIGH}$	14.5	15.1	15.7	V
Channel Clamp Current Low	$I_{CLMP\_LOW}$	Channel pull-down current when SINKx > $CH_{CLMP\_LOW}$ , $R_{SET} = 7.32\text{ k}\Omega$	315	350	385	mA
Channel Clamp Current High	$I_{CLMP\_HIGH}$	Channel pull-down current when SINKx > $CH_{CLMP\_HIGH}$	430	510	600	mA
Channel Clamp Hysteresis	$V_{CH\_CLMP\_HYS}$	Hysteresis after either channel clamp is triggered		1.2		V
Lowest SINKx Current		Output current for DIM = 0 V and $R_{SET} = 10\text{ k}\Omega$ (see Figure 15)		125		$\mu A$
<b>INPUT CONTROLS</b>						
Input Threshold (Low)	$V_{IL}$				0.6	V
Input Threshold (High)	$V_{IH}$		1.1			V
EN Input Resistance	$R_{EN}$	EN = 1.2 V		400		k $\Omega$
MODE Pin Pull-Up Current	$I_M$		15	20	24	$\mu A$
MODE Threshold 1, 30.1 k $\Omega$	$V_{M1}$	Threshold for increasing mode voltage to enter dc buffer operation	0.35	0.4	0.45	V
MODE Threshold 2, 52.3 k $\Omega$	$V_{M2}$	Threshold for increasing mode voltage to enter PWM buffer operation	0.75	0.8	0.85	V
MODE Threshold 3	$V_{M3}$	Threshold for increasing mode voltage to enter PWM EA operation	1.25	1.3	1.35	V
<b>LED SCALING CONTROLS</b>						
DIM and VT Limit Voltage	$V_{T\_LIMIT}$	VT (and DIM if MODE = GND) voltage to produce 100% output current	1.9	2.0	2.1	V
Dimming Accuracy	$I_{LED\_DIM1}$	$I_{LED\_DIM1}/I_{LED\_100}$ , VT = 1 V, MIN = 0 V, $R_{SET} = 25.5\text{ k}\Omega$	48	50	52	%
	$I_{LED\_DIM2}$	$I_{LED\_DIM2}/I_{LED\_100}$ , DIM = 0.2 V, MODE = GND, $R_{SET} = 25.5\text{ k}\Omega$	9.4	10	10.4	%
	$I_{LED\_DIM3}$	$I_{LED\_DIM3}/I_{LED\_100}$ , DIM = 50%, 140 Hz, MODE = REG, $R_{SET} = 25.5\text{ k}\Omega$	48	50	52	%
VT Pull-Up Current Source				0.6	1	$\mu A$
DIM Pin Frequency Range		MODE = REG	0.14		40	kHz
MIN Comparator Hysteresis	$V_{MIN\_HYS}$			55		mV
MIN Pin PWM Mode Threshold	$V_{MIN\_PWM}$	Voltage on MIN pin at which VT changes from scaling LED current to pulsing LED current	2.2	2.3	2.4	V
PWM Delay and Rise/Fall Time		Delay from VT low to high (or high to low) to LED current low to high (or high to low), MIN = REG		20		$\mu s$
<b>THERMAL FOLDBACK (INTERNAL)</b>						
Thermal Foldback Threshold	$T_{FB\_THRES}$			135		$^{\circ}C$
Thermal Shutdown Threshold	$T_{SD\_THRES}$			150		$^{\circ}C$
Thermal Shutdown Hysteresis	$T_{SD\_HYS}$			20		$^{\circ}C$
<b>FAULT DETECTION</b>						
$\overline{FAULT}$ Threshold	$V_{FAULT\_TH}$	Threshold for $\overline{FAULT}$ comparator	1.14	1.2	1.26	V
$\overline{FAULT}$ Hysteresis	$V_{FAULT\_HYS}$	Hysteresis for $\overline{FAULT}$ comparator		100		mV
$\overline{FAULT}$ Filter	$t_{FAULT}$	VO_SNS and $\overline{FAULT}$ shutdown noise filter		10		$\mu s$
$\overline{FAULT}$ Pull-Down Resistance	$\overline{FAULT}_{PD}$	Fault activated	7	15	20	$\Omega$
VO_SNS Threshold	$V_{VO\_SNS\_TH}$	Threshold for VO_SNS comparator	1.176	1.2	1.224	V
VO_SNS Hysteresis	$V_{VO\_SNS\_HYS}$	Hysteresis for VO_SNS comparator		50		mV
VO_SNS Leakage Current	$I_{VO\_SNS}$				50	nA
Open SINKx Fault Threshold	$V_{SFD\_OPEN}$	SINKx pin voltage threshold to remove a sink from the feedback loop after a VOUT_OVP fault		80		mV

Parameter	Symbol	Test Conditions/Comments	Min	Typ	Max	Unit
Channel Overvoltage Threshold	V <sub>CH_OVP</sub>	Threshold on SINKx to trigger CH_OVP fault	5.3	5.7	6.1	V
Channel Overvoltage Hysteresis	V <sub>CH_OVP_HYS</sub>	Hysteresis after V <sub>CH_OVP</sub> is triggered		1.2		V
Short SINKx Fault Threshold	V <sub>SFD_SHORT</sub>	SINKx pin voltage threshold to remove a sink from the feedback loop after a CH_OVP fault		525		mV

## ABSOLUTE MAXIMUM RATINGS

Table 2.

Parameter	Rating
VIN, FB_OUT to GND	−0.3 V to +31 V
SINKx to GND	−0.3 V to +21 V
MODE, COMP, REG, MIN, DIM, VT, ISET to GND	−0.3 V to +3.6 V
EN, FAULT, VO_SNS to GND	−0.3 V to +6.0 V
Operating Ambient Temperature Range	−40°C to +105°C <sup>1</sup>
Operating Junction Temperature Range	−40°C to +125°C
Maximum Junction Temperature	150°C
Storage Temperature Range	−45°C to +150°C
Soldering Conditions	JEDEC J-STD-020
ESD (Electrostatic Discharge)	
Human Body Model (HBM)	±1.5 kV
Charged Device Model (CDM)	±500 V

<sup>1</sup> The maximum operating junction temperature ( $T_{J(MAX)}$ ) supersedes the maximum operating ambient temperature ( $T_{A(MAX)}$ ). See the Maximum Temperature Ranges section for more information.

Stresses at or above those listed under Absolute Maximum Ratings may cause permanent damage to the product. This is a stress rating only; functional operation of the product at these or any other conditions above those indicated in the operational section of this specification is not implied. Operation beyond the maximum operating conditions for extended periods may affect product reliability.

Absolute maximum ratings apply individually only, not in combination. Unless otherwise specified, all voltages are referenced to GND.

## MAXIMUM TEMPERATURE RANGES

The maximum operating junction temperature ( $T_{J(MAX)}$ ) supersedes the maximum operating ambient temperature ( $T_{A(MAX)}$ ). Therefore, in situations where the ADP8140 is exposed to poor thermal resistance and a high power dissipation ( $P_D$ ), the maximum ambient temperature may need to be derated. In these cases, the ambient temperature maximum can be calculated with the following equation:

$$T_{A(MAX)} = T_{J(MAX)} - (\theta_{JA} \times P_{D(MAX)})$$

## THERMAL RESISTANCE

$\theta_{JA}$  (junction to air) is specified for the worst-case conditions, that is, a device soldered in a circuit board for surface-mount packages. The  $\theta_{JA}$ ,  $\theta_{JB}$  (junction to board), and  $\theta_{JC}$  (junction to case) are determined according to JESD51-9 on a 4-layer printed circuit board (PCB) with natural convection cooling. The LFCSP exposed pad must be soldered to GND.

Table 3. Thermal Resistance

Package Type	$\theta_{JA}$	$\theta_{JB}$	$\theta_{JC}$	Unit
16-Lead LFCSP	33.2	12.4	2.4	°C/W

## ESD CAUTION



**ESD (electrostatic discharge) sensitive device.** Charged devices and circuit boards can discharge without detection. Although this product features patented or proprietary protection circuitry, damage may occur on devices subjected to high energy ESD. Therefore, proper ESD precautions should be taken to avoid performance degradation or loss of functionality.

## PIN CONFIGURATION AND FUNCTION DESCRIPTIONS

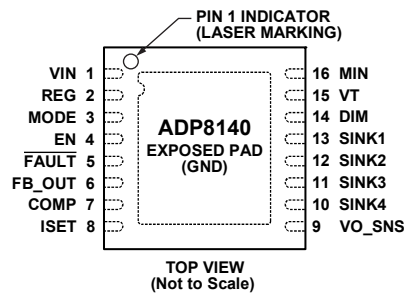

NOTES  
1. CONNECT THE EXPOSED PAD OF THE LFCSP TO GROUND.

Figure 3. Pin Configuration

Table 4. Pin Function Descriptions

Pin No.	Mnemonic	Description
1	VIN	Supply Voltage Input (3.0 V to 30 V).
2	REG	Regulated 3.0 V (Typical) Source. Connect a 1.0 $\mu$ F (or greater) capacitor from REG to ground.
3	MODE	Operation Mode. If MODE is connected to ground, the device is placed in dc EA operation. If MODE is connected to REG, the device is placed in PWM EA operation. If MODE is connected via a 30.1 k $\Omega$ resistor to ground, the device is placed in dc low gain buffer operation. If MODE is connected via a 52.3 k $\Omega$ resistor to ground, the device is placed in PWM low gain buffer operation. The MODE pin is read only once at power-up (when VIN exceeds 3 V). Any changes to the MODE pin after applying power are ignored. See the MODE Pin Operation section for more information.
4	EN	Enable Input. Pull high (above $V_{IH(MIN)}$ ) to enable the device. EN is internally pulled low with a 400 k $\Omega$ (typical) resistor.
5	$\overline{\text{FAULT}}$	Fault Output. This pin must be connected to an external pull-up resistor. If using multiple ADP8140 ICs in parallel, all FAULT pins must be connected together.
6	FB_OUT	Feedback Output. The FB_OUT pin is a control signal for the external power stage. The action of this pin depends on the MODE setting.
7	COMP	Compensation Pin for EA. The COMP pin is a control signal for the external power stage. COMP is a dual function pin. The action of this pin depends on the MODE setting.
8	ISET	Output Current Setting. Connect a resistor to ground to set the output current. If left floating, the current sinks are set to 15 mA.
9	VO_SNS	Overvoltage Protection Sensing Input. Connect the VO_SNS pin through a resistor divider to the top of the LED strings, or connect it to ground to disable overvoltage sensing.
10	SINK4	Current Sink for LED Channel 4.
11	SINK3	Current Sink for LED Channel 3.
12	SINK2	Current Sink for LED Channel 2.
13	SINK1	Current Sink for LED Channel 1.
14	DIM	Dim Input. The DIM pin scales the LED current from the PWM signal or dc voltage. The action of this pin depends on the MODE setting.
15	VT	Voltage Threshold. VT is a dual function pin. If MIN < 2.2 V at startup, VT is an analog current reduction pin. A voltage on VT scales the LED current. If MIN is connected to REG at startup, a PWM signal applied to VT pulses the LED current.
16	MIN	Minimum Voltage Threshold. If MIN < 2.2 V at startup, the MIN voltage sets the minimum voltage threshold for the VT pin. VT voltages below the MIN voltage shuts down the power stage. If MIN is connected to REG at startup, a PWM signal applied to VT pulses the LED current.
	EPAD (GND)	Exposed Pad (Ground). Connect the exposed pad of the LFCSP to ground.

# TYPICAL PERFORMANCE CHARACTERISTICS

V<sub>IN</sub> = 12 V, EN = DIM = V<sub>T</sub> = 3.0 V, MIN = MODE = 0 V, V<sub>SINKx</sub> = 450 mV, T<sub>A</sub> = 25°C, unless otherwise noted.

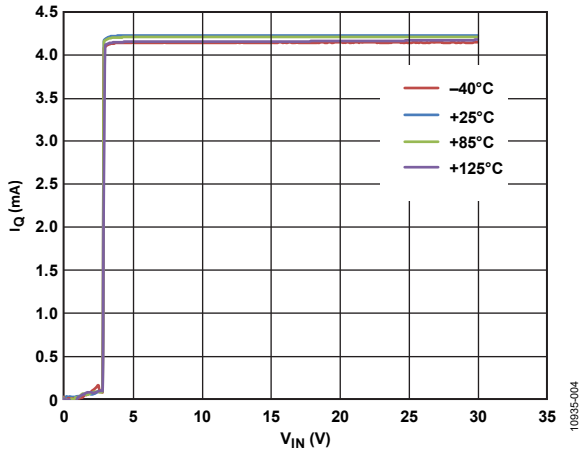

Figure 4. Typical Operating Current vs. V<sub>IN</sub>, EN = 3 V, R<sub>SET</sub> = 71.5 kΩ

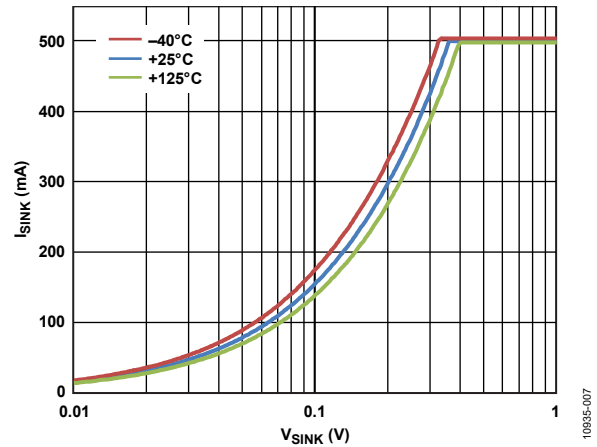

Figure 7. Typical Sink Current vs. Sink Voltage, R<sub>SET</sub> = 5.11 kΩ

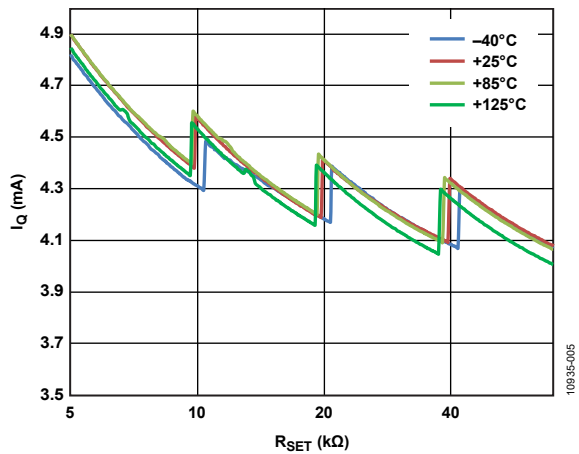

Figure 5. Typical Operating Current vs. R<sub>SET</sub>

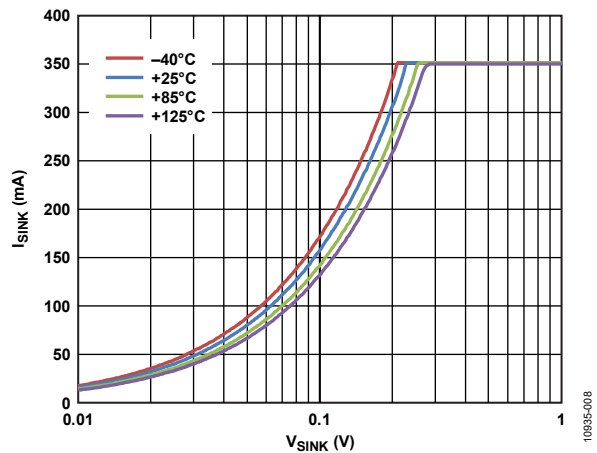

Figure 8. Typical Sink Current vs. Sink Voltage, R<sub>SET</sub> = 7.32 kΩ

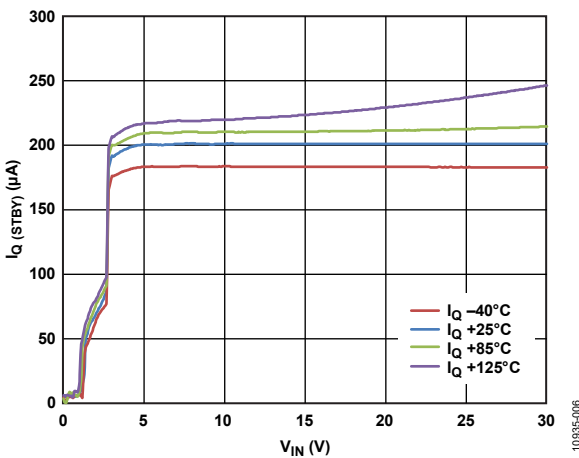

Figure 6. Typical Standby Current vs. V<sub>IN</sub>, EN = 0 V

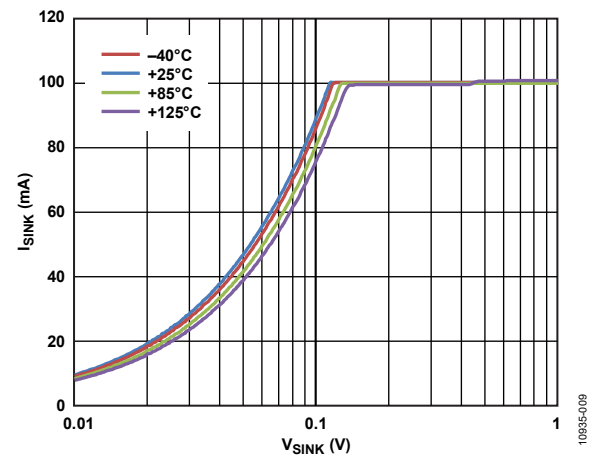

Figure 9. Typical Sink Current vs. Sink Voltage, R<sub>SET</sub> = 25.5 kΩ

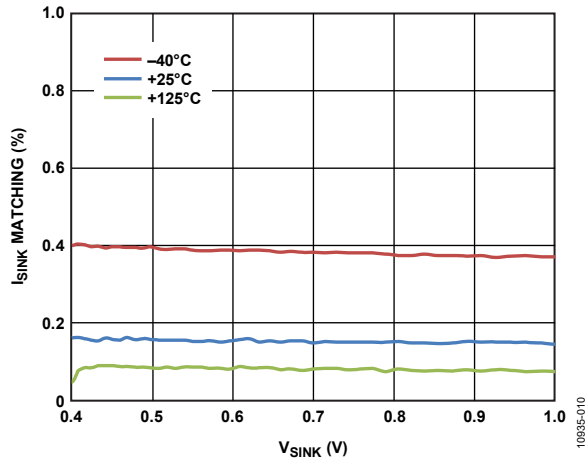

Figure 10. Typical Sink Current Matching vs. Sink Voltage,  $R_{SET} = 5.11 \text{ k}\Omega$

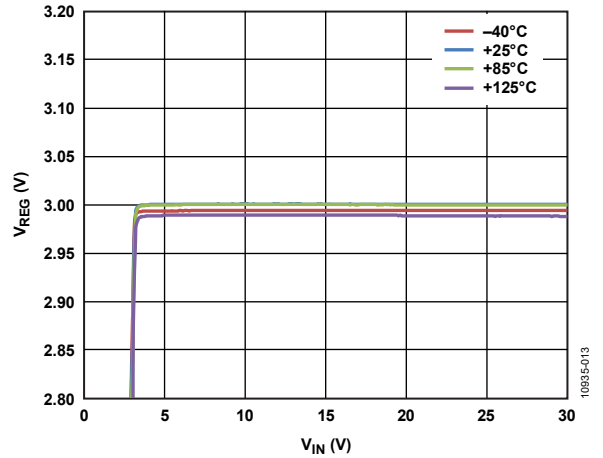

Figure 13. REG Voltage vs. Input Voltage

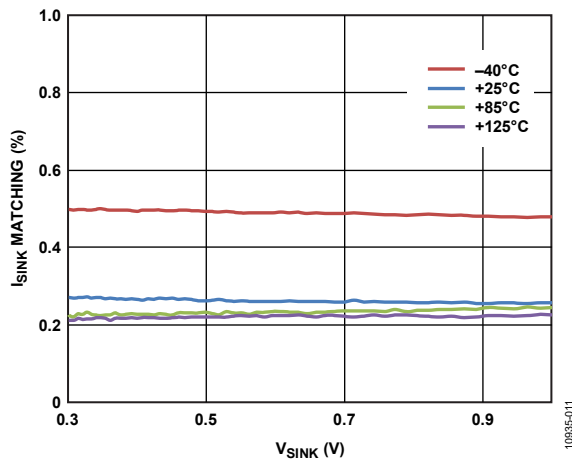

Figure 11. Typical Sink Current Matching vs. Sink Voltage,  $R_{SET} = 7.32 \text{ k}\Omega$

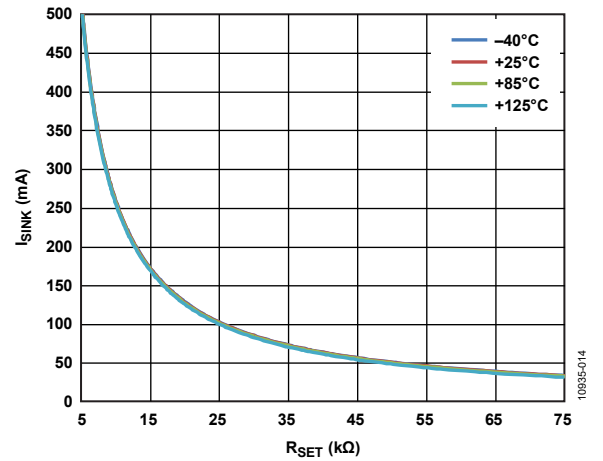

Figure 14. Sink Current vs.  $R_{SET}$  (DIM = 3 V)

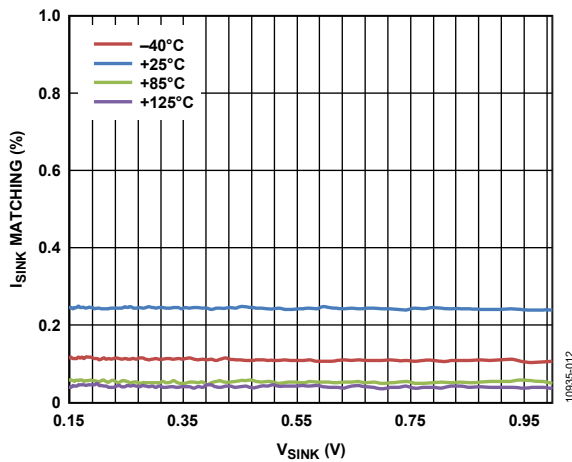

Figure 12. Typical Sink Current Matching vs. Sink Voltage,  $R_{SET} = 25.5 \text{ k}\Omega$

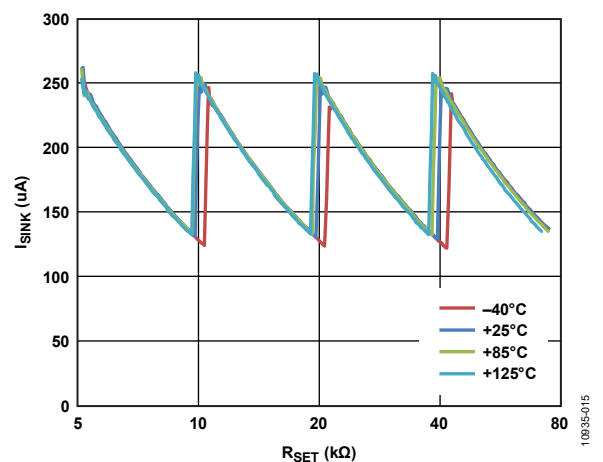

Figure 15. Sink Current vs.  $R_{SET}$  (DIM = 0 V)

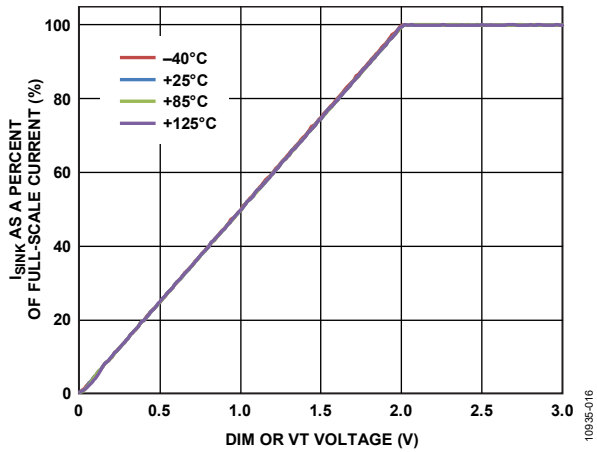

Figure 16. Typical Sink Current vs. DIM or VT Voltage (MODE = 0, MIN = 0 V)

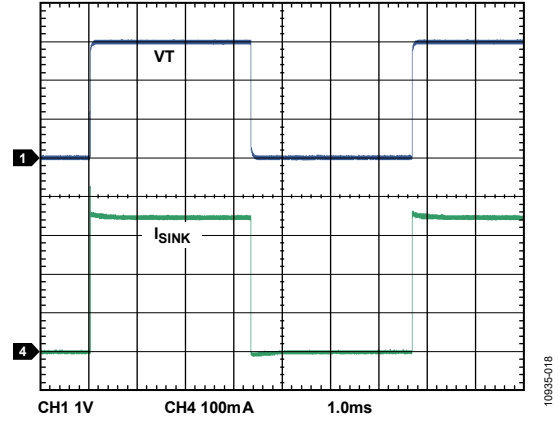

Figure 18. Typical Sink Current Waveforms with PWM on VT Pin (MIN = 3 V)

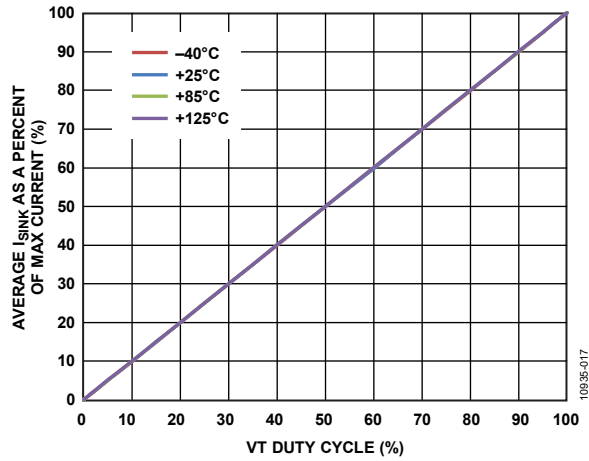

Figure 17. Typical Average Sink Current vs. VT Duty Cycle (MIN = 3 V, VT Frequency = 120 Hz)

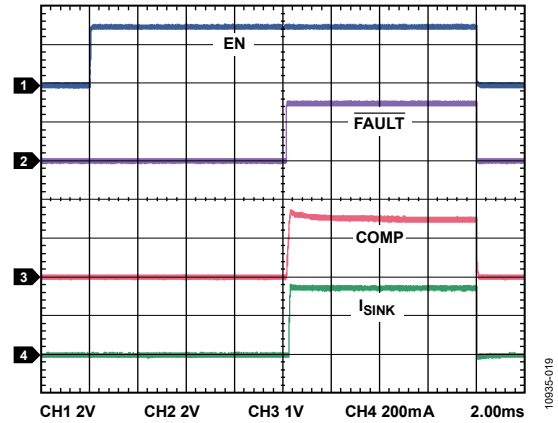

Figure 19. Start-Up Sequence (See Figure 1 Setup)

## THEORY OF OPERATION

The ADP8140 provides high current control of up to four LED channels. Each driver can sink up to 500 mA. One external resistor programs the sink current for all four channels. The device features a feedback output that controls an external power supply for optimal efficiency. The ADP8140 also protects the LEDs, power supply, and itself against thermal events, short circuits, and LED open circuits. Multiple ADP8140 ICs are easily connected in parallel to drive additional LED strings or higher current LEDs.

### START-UP SEQUENCE

To start the ADP8140, VIN must be applied in excess of the UVLO threshold and the EN pin must be high. However, even with EN low, the REG pin produces a constant 3.0 V (typical) on its output. REG can be used as a low current supply, as

needed. In this operation, with EN low, the ADP8140 consumes no more than 200  $\mu$ A (typical). A 400 k $\Omega$  (typical) resistor from EN to GND ensures that the ADP8140 is shut down in the event of an open connection on the EN pin.

When EN also goes high, the power stage starts up and the current sinks are enabled. There is an approximate 8 ms delay after EN goes high. When the sinks are enabled, the FAULT pin is released and the COMP and FB\_OUT pins begin their normal regulation. When EN goes low, the SINKx pins are left on for another 100  $\mu$ s to discharge any voltage from the power stage output. The device then enters low current consumption operation.

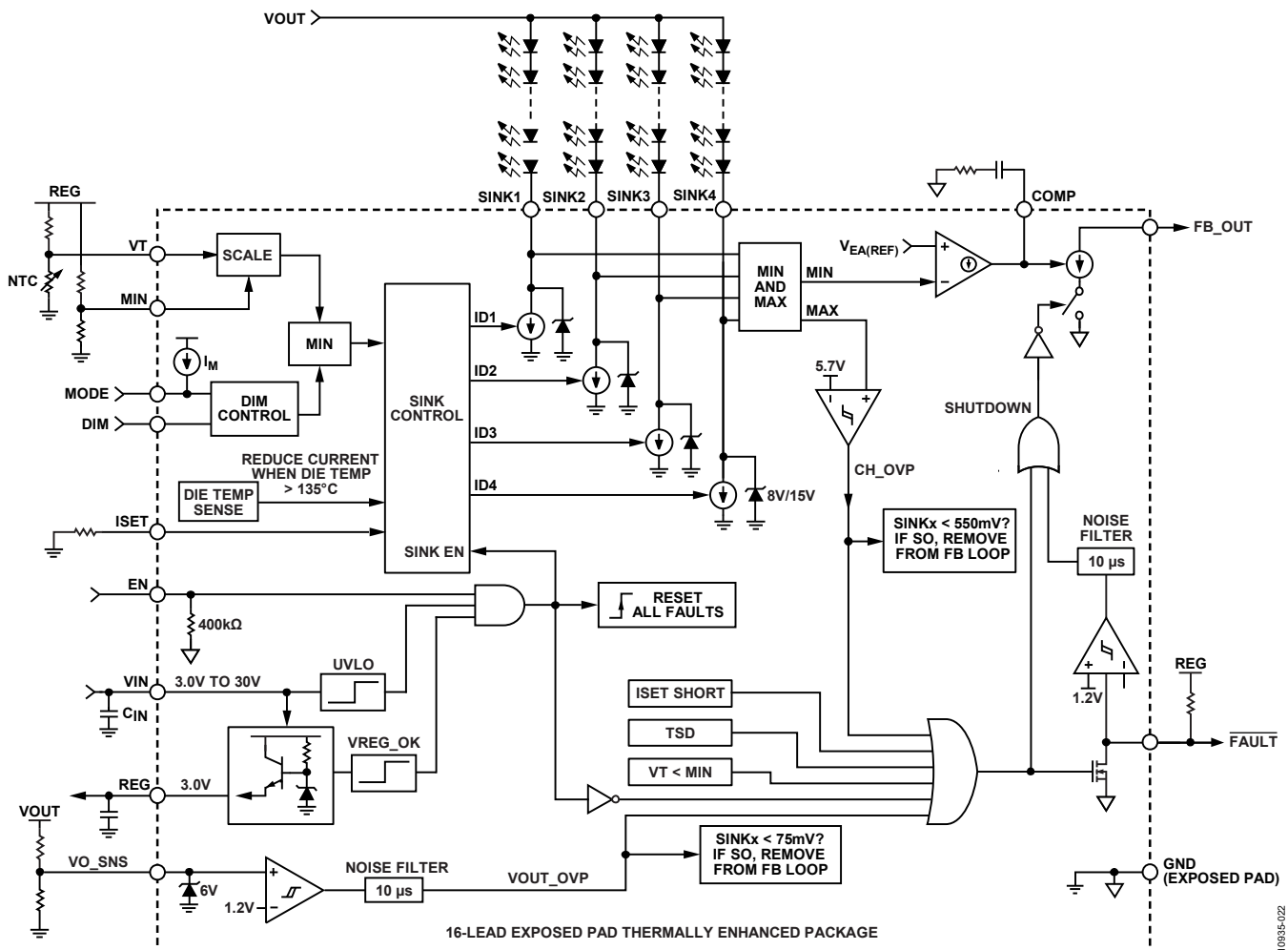

Figure 20. Detailed Block Diagram

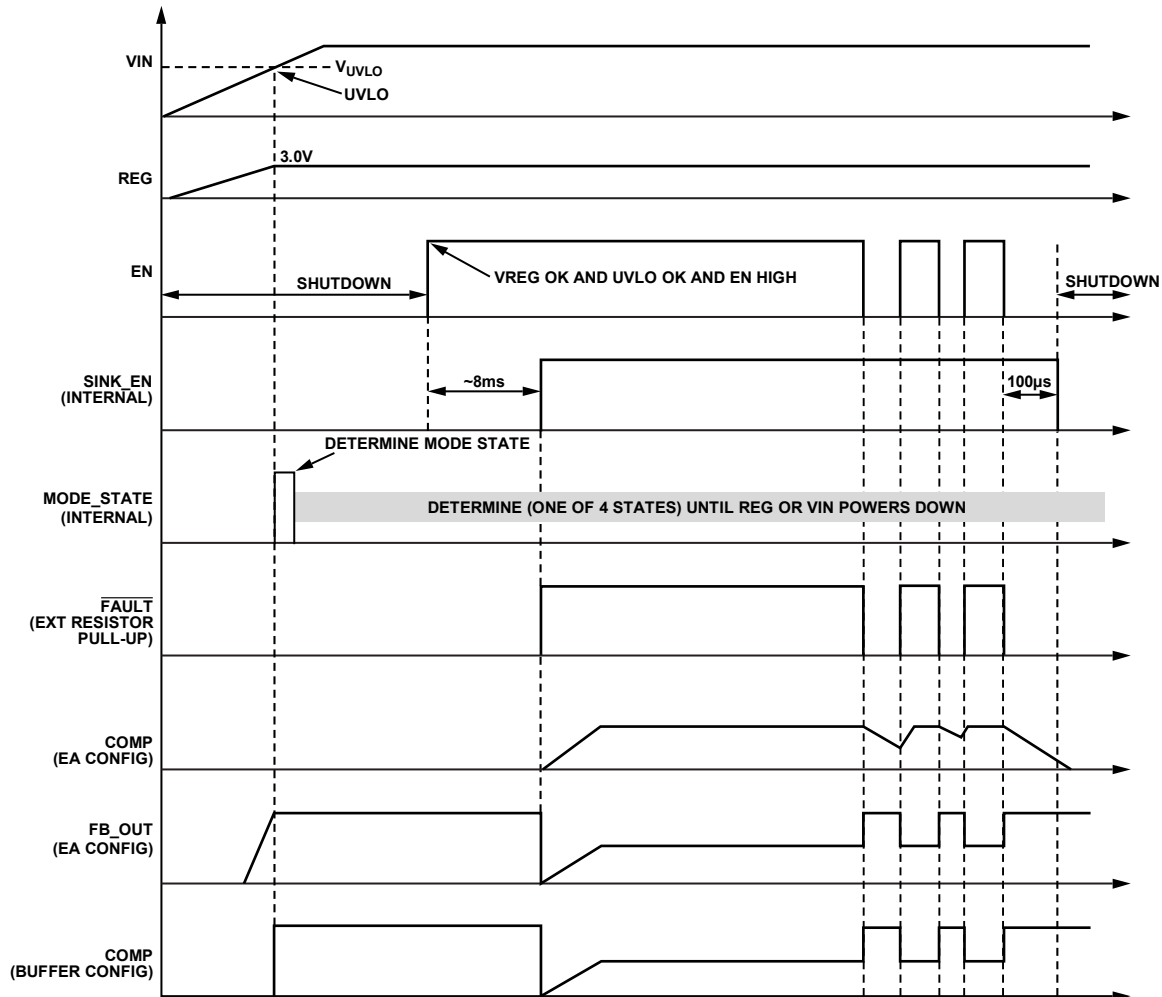

Figure 21. Start-Up Timing and Signals

## CURRENT SINKS

The ADP8140 contains four internal current sinks. Each current sink is capable of delivering 125  $\mu\text{A}$  to 500 mA. To ensure accurate regulation, the voltage on the current sinks must be greater than the maximum headroom voltage given in Table 1. For additional information on the headroom voltage, see Figure 7 to Figure 9. All current sinks have their maximum current set by the external resistor,  $R_{\text{SET}}$ . To determine the value of  $R_{\text{SET}}$ , use Equation 1. A graph of sink current vs.  $R_{\text{SET}}$  is shown in Figure 14.

$$R_{\text{SET}} (\text{k}\Omega) = \frac{2560}{I_{\text{SINK}} (\text{mA})} \quad (1)$$

Multiple sinks can be combined together for higher currents per LED string. For example, two sinks can be shorted together to drive two strings of LEDs, each at up to 1 A, or four sinks combined to drive one string of LEDs at up to 2.0 A.

A resistor must always be connected to the ISET pin. However, in the event that ISET is accidentally left open, the ADP8140 defaults to a typical current of 15 mA (typical) per sink. If ISET is accidentally shorted to GND, the ADP8140 limits the current

per sink to 570 mA (typical) and shuts down the power stage (FAULT goes low and FB\_OUT and COMP are disabled).

Each current sink has a maximum rated voltage of 20 V. However, the maximum output voltage driving all the current sinks, through the LEDs, is allowed to exceed 20 V. The LEDs drop enough voltage so that the SINKx voltage remains close to the FB\_OUT EA accuracy value,  $V_{\text{EA(REF)}}$  (where REF is the reference voltage). Because the ADP8140 controls the power stage, the voltage is not present when off or during a fault. Therefore, the ADP8140 can be safely used in conjunction with power supplies that produce over 100 V for their output.

## POWER CONTROL OPERATION

The ADP8140 controls a power stage with its COMP and FB\_OUT pins. The power stage allows the IC to optimize the efficiency and protection of the LEDs. The ADP8140 operates in two power control modes: error amplifier and low gain buffer. The MODE pin is used to select the power control mode.

**MODE PIN OPERATION**

The MODE pin is used to program one of four possible modes of operation. The condition of the MODE pin affects the DIM pin input (see the Reducing the LED Current with the DIM Pin section) and the power control mode (see Power Control Modes section). The MODE pin state is read at power-up only, when VIN crosses the UVLO threshold. After this point, the MODE pin voltage is 0 V. The MODE status cannot change after power-up.

**Table 5. Modes of Operation Programmed by the MODE Pin**

MODE Connection	DIM Pin Mode	Power Control
GND	Analog voltage	Error amplifier
30.1 kΩ to GND	Analog voltage	Low gain buffer
52.3 kΩ to GND	PWM signal	Low gain buffer
REG	PWM signal	Error amplifier

**POWER CONTROL MODES**

**Error Amplifier Power Control**

In the error amplifier power control mode, the ADP8140 applies the minimum voltage of the four current sinks to the inverting input of an internal error amplifier. The output of this error amplifier connects to the FB\_OUT inverting buffer.

The FB\_OUT pin outputs a current, which indicates power control. A higher FB\_OUT sink current indicates that more power is required to the LEDs. A lower FB\_OUT sink current indicates that less power is required for the LEDs. This operation makes the FB\_OUT ideal for any power control application that does not normally have an error amplifier. The two primary applications for this are as follows:

- Controlling an optocoupler on the secondary side of an isolated power supply
- Controlling a PMOS transistor to regulate power in a fixed output voltage supply.

Depending on the power stage used, an RC network must be connected to the COMP pin. The COMP pin connects to the output of the FB\_OUT transconductance amplifier. To select the COMP resistor and capacitor values, a free simulation tool, ADIsimPE, is available at: [www.analog.com/ADIsimPE](http://www.analog.com/ADIsimPE).

Using this tool, and the included ADP8140 circuit model, the loop control and stability can be easily simulated and adjusted for different setups.

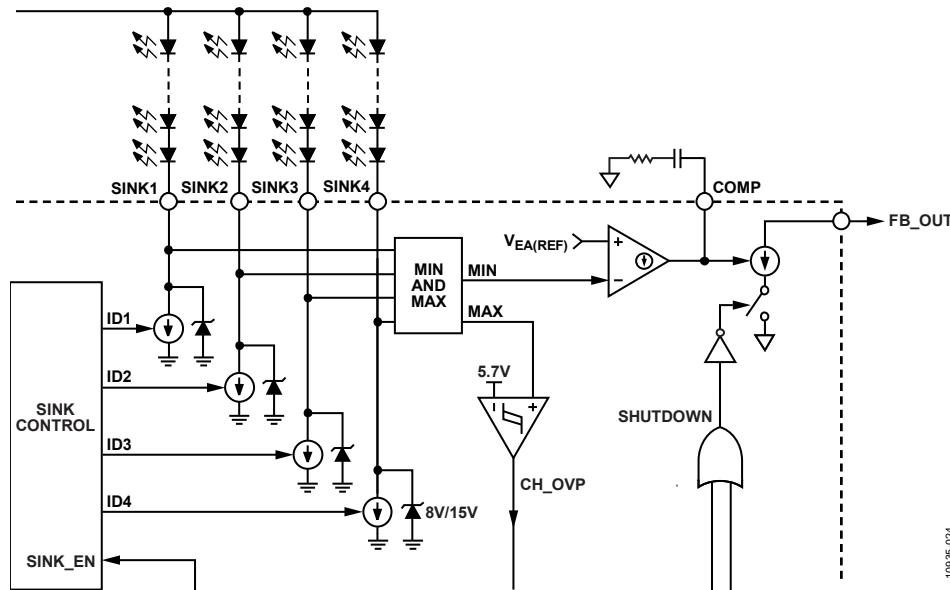

Figure 22. Error Amplifier Power Control

10935F-024

### Low Gain Buffer Power Control

In the low gain buffer power control mode, the ADP8140 multiplies the minimum voltage of the four current sinks by  $G_{BUFF}$  (3.9 typical; see Table 1) and outputs it to the COMP pin. This mode allows the ADP8140 to easily control nearly any switched mode power supply (SMPS) control IC, such as a buck regulator or boost controller. Common examples are shown in Figure 32 to Figure 36.

In this mode, the COMP pin is connected to the feedback (FB) input of an SMPS controller. The FB\_OUT pin can be left floating or connected to GND. Do not tie it to COMP or any other pin. Connect the FAULT pin to the EN signal of the SMPS IC. This connection ensures that the power delivery immediately shuts down in the event of a fault.

The values of R1, R2, and R3 program the minimum headroom voltage on the SINKx pins and set the maximum voltage that the SMPS FB input receives. A spreadsheet is available at [www.analog.com/ADP8140](http://www.analog.com/ADP8140) to assist in these calculations.

Otherwise, to find the values start with the following equation:

$$R2 = R1 \times \left( \frac{3.9 \times V_{HR}}{FB\_REF} - 1 \right)$$

where:

$FB\_REF$  is the internal error amplifier reference voltage of the SMPS IC. This is typically 600 mV or 1.2 V. However, it does vary for different ICs; therefore, consult the data sheet of that IC.  $V_{HR}$  is the minimum headroom voltage that the ADP8140 current sinks need (see Figure 7 to Figure 9). This value varies based on the maximum sink current that is programmed on the ISET pin.

Set the value of R1 to be small enough so that the internal 250 k $\Omega$  pull-down resistance on the COMP pin does not affect the total resistance. For example, if  $R1 = 10 \text{ k}\Omega$ ,  $V_{HR} = 325 \text{ mV}$ , and  $FB\_REF = 600 \text{ mV}$ , then

$$R2 = 10 \text{ k}\Omega \times \left( \frac{3.9 \times 0.325}{0.6} - 1 \right) = 11.1 \text{ k}\Omega$$

Next, select R3 to set the maximum voltage applied to the SMPS FB input.

$$R3 = \frac{V_{REG} \times R1}{FB_{MAX}} - R1 - R2$$

where  $FB_{MAX}$  is the maximum voltage desired on the SMPS FB input. Therefore, if  $FB_{MAX} = 720 \text{ mV}$ ,

$$R3 = \frac{3 \text{ V} \times 10 \text{ k}\Omega}{0.720} - 10 \text{ k}\Omega - 11.1 \text{ k}\Omega = 20.6 \text{ k}\Omega$$

Ensure that  $FB_{MAX}$  is sufficiently higher than the maximum  $FB\_REF$  operating point. Some extra margin is beneficial.

### DIMMING THE LED CURRENT

The ADP8140 offers multiple methods of dimming. The dimming input can be either an analog voltage or a PWM signal. The LED output current can be either scaled (dc dimming) or pulsed on and off in response to the PWM input signal. The two dimming pins, DIM and VT, provides different functions, but both pins can be used for dimming simultaneously, which provides enormous flexibility in controlling the LED current.

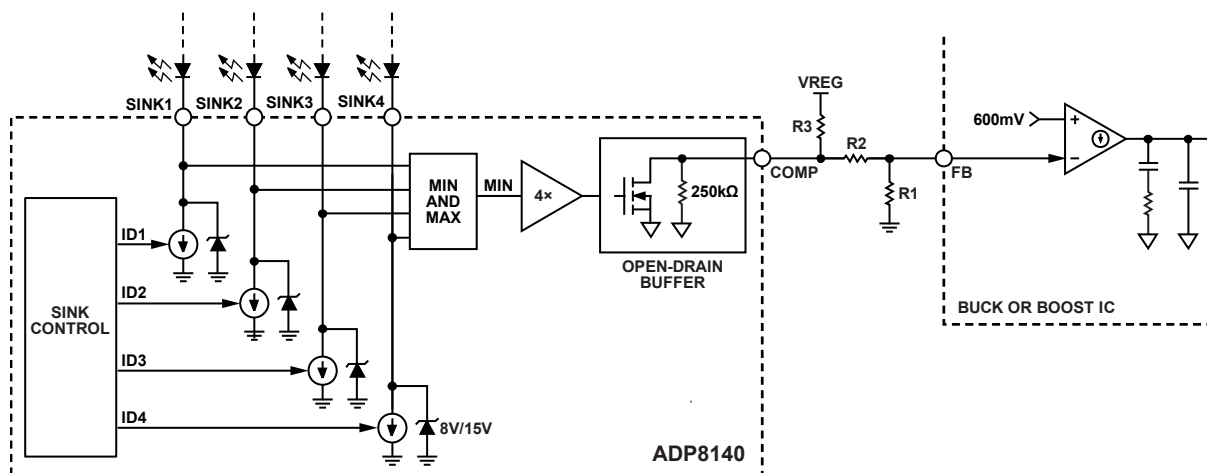

Figure 23. Low Gain Buffer Power Control

10935-025

## REDUCING THE LED CURRENT WITH THE DIM PIN

The DIM pin scales the output current when either an analog voltage or a PWM signal is applied to it. The response of the ADP8140 to the DIM pin depends on the condition of the MODE pin.

If the MODE pin is connected to GND or a 30.1 k $\Omega$  resistor at startup, the DIM pin functions as an analog input. As such, a DIM voltage of 2 V or greater does not impact the output current. A DIM voltage of 0 V reduces the output current to as low as 125  $\mu$ A (see Figure 15). Any DIM voltage between 0 V and 2 V linearly scales the output current.

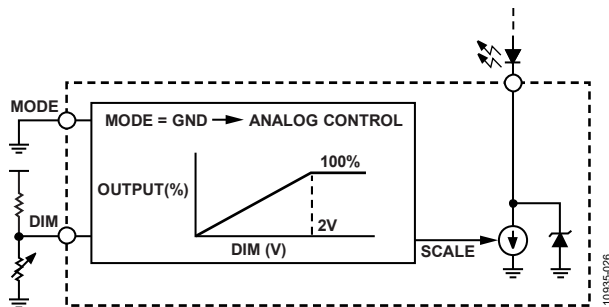

Figure 24. Reducing the Output Current by Applying an Analog Voltage to the DIM Pin

If MODE is connected to REG or to a 52.3 k $\Omega$  resistor at startup, a PWM duty cycle applied to the DIM pin is internally filtered and used to scale the output currents. Set the DIM pin frequency between 140 Hz and 40 kHz. A lower frequency PWM signal gives the ADP8140 more information about the applied duty cycle and leads to better resolution of the duty cycle, which translates into smaller LED current step sizes on the current sink digital-to-analog converters (DACs).

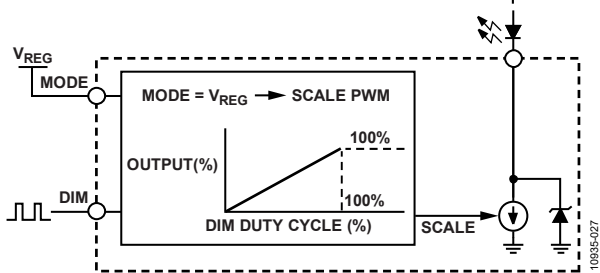

Figure 25. Reducing the Average Output Current by Pulse Width Modulating the Current Sinks with the DIM Pin

When DIM = 0 V, or 0% duty cycle, the minimum output current is a function of the programmed R<sub>SET</sub> value. This minimum value varies between 125  $\mu$ A and 250  $\mu$ A, depending on the R<sub>SET</sub> value. The typical value as a function of R<sub>SET</sub> is shown in Figure 15 of the Typical Performance Characteristics section.

## DIMMING LEDs WITH THE VT PIN

The VT pin has two modes of operation, depending on the configuration of the MIN pin.

If MIN is connected to REG at startup, a PWM input to the VT pin pulses the LED current sinks. If the PWM input is high, the

current goes to the value dictated by the ISET and DIM pins. If the PWM input is low, the current becomes the minimum current as defined in Figure 15. This small current allows the LEDs to be slightly biased and minimizes the voltage difference between the off and on states, which greatly reduces the response time of the power delivery loop.

In this mode, the 7.75 V SINKx clamp is disabled. When the clamp is disabled, the voltages on the SINKx pins rise as high as 15.1 V (typical) during the LED off time.

If MIN < 2.2 V, the voltage on the VT pin linearly scales the LED current. VT voltages greater than 2 V (typical) produce 100% of the programmed ISET current. When VT is less than 2 V, the output current is reduced 1% per 20 mV. If the voltage on the VT pin is below the voltage on the MIN pin, the power supply to the LEDs is disabled. If the VT pin voltage rises above the MIN threshold, plus some hysteresis, the power supply is reenabled. If both the VT pin and the DIM pin are used for analog dimming, the pin that gives the lower LED current is used to set the LED current.

To implement thermal protection of the LEDs, the VT pin is connected to an external negative temperature coefficient (NTC) resistor. This NTC resistor is typically placed on the LED heat sink. Selecting the value of the NTC and the resistor in the network shapes the slope of the VT voltage in response to the LED temperature. A resistor divider on the MIN pin sets the level at which the power stage (FB\_OUT and COMP) are disabled.

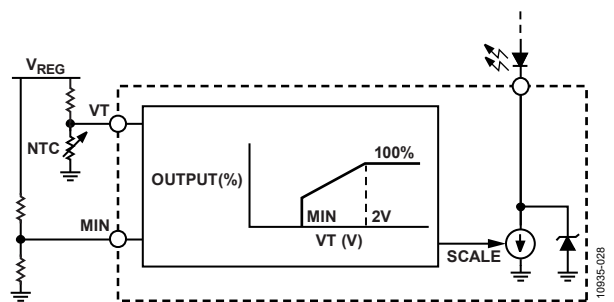

Figure 26. Using an External NTC to Implement LED Thermal Protection

## FAULT PROTECTIONS

To ensure the safety of the LEDs, the ADP8140 IC, and the power source, the ADP8140 includes a comprehensive array of detection and protection features.

- Power supply overvoltage protection
- LED overtemperature protection
- LED short-circuit protection
- LED open-circuit protection
- IC overtemperature protection
- Shorted ISET protection
- Open ISET and EN protection

These features are summarized in the flowchart shown in Figure 27.



left enabled, so that they can regulate the current if the open-circuit or short-circuit LED condition is removed. Bringing EN or VIN low and then high again restores all sinks to the feedback loop.

VO\_SNS can also be used to monitor the input voltage. When connected to the input voltage through a resistor divider, the ADP8140 shuts down and disables any power stages if the supply input voltage rises too high. This shutdown can help to protect the LEDs and power stage.

**DIE TEMPERATURE PROTECTION**

Significant voltage mismatch between LED strings can create high power dissipation within the ADP8140. If this increase in power dissipation causes the die temperature on the ADP8140 to rise above 135°C (typical), the IC automatically begins to reduce the output current on all four sinks. If the die temperature continues to rise and exceeds 150°C (typical), the ADP8140

shuts down the power stage with COMP, FB\_OUT, and FAULT. When the temperature drops below 130°C (typical), the ADP8140 restarts the power stage. If the fault or high power dissipation persists, the sequence repeats.

**USING MULTIPLE ADP8140 ICs**

Multiple ADP8140 ICs can be combined in parallel to control the same supply. This combination is advantageous to control more than four strings of LEDs or to drive higher currents. For example, using two ADP8140 ICs, four LED strings can be driven at 1 A each, or two strings can be driven at 2 A each.

When using multiple ADP8140 ICs in parallel to control one power supply, all of the FAULT and EN pins must be connected together. If any FAULT pin goes low, all ADP8140 ICs respond to the event. Most applications will work best if the dimming signals are also connected amongst the ADP8140 ICs, though it is not required.

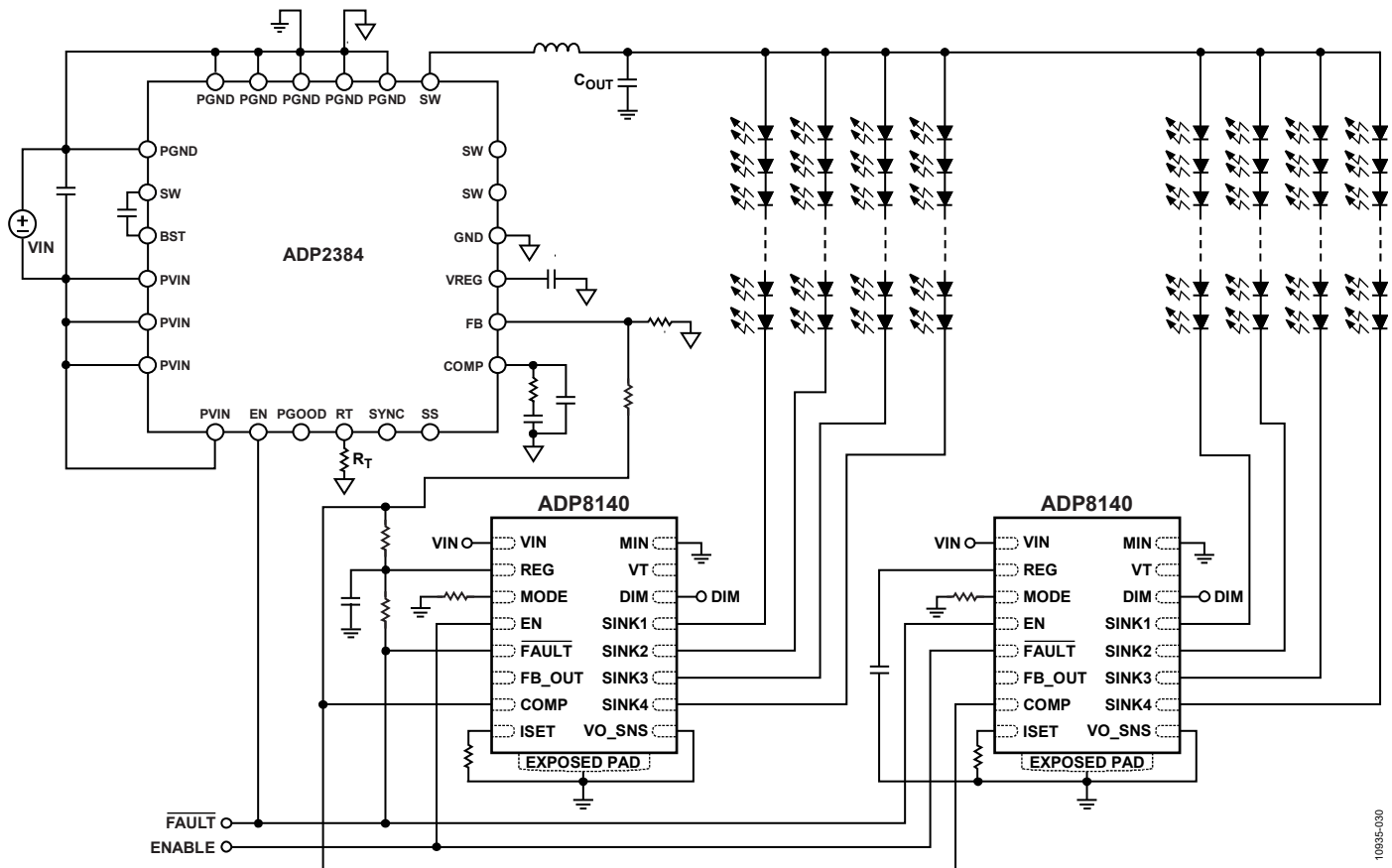

Figure 28. Multiple ADP8140 ICs Powered from One Supply (Low Gain Buffer Control Shown)

10935-030

## OPERATING THE ADP8140 FROM HIGHER INPUT VOLTAGES

The ADP8140 is capable of operating from an input voltage ( $V_{IN}$ ) range of 3.0 V to 30 V. However, higher voltages can be used to power the ADP8140 when an appropriate current limiting circuit is used.

It is sometimes sufficient to limit the voltage on the VIN pin by placing a Zener diode on VIN and limiting the current with a resistor from the input voltage to the VIN pin. This method can be used if standby power dissipation is not an issue.

Alternatively, if the supply voltage range is small, an additional Zener diode between the supply and the VIN pin shifts the voltage at the VIN pin below 30 V. This method adds minimal power dissipation in both standby and active modes.

However, a more robust voltage limiter uses a Zener diode, an NPN transistor, and two resistors. This simple circuit, shown in Figure 29, gives the required operating  $I_Q$  during normal operation but also reduces the standby current when the ADP8140 is disabled.

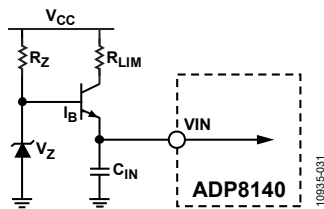

Figure 29. VIN Current Limiting Circuit for High Input Voltages

Select  $V_Z$  to give a voltage well below the 30 V absolute maximum of the VIN pin. With this circuit, the VIN pin voltage is regulated to about  $V_Z - 0.7$  V. Select the resistor,  $R_Z$ , to limit the current when the ADP8140 is disabled yet still provide enough current to reverse bias the Zener diode and drive the NPN transistor when the ADP8140 is active. The current through  $R_Z$  is given by

$$I_{RZ} = \left( \frac{V_{CC} - V_Z}{R_Z} \right)$$

A value of 100  $\mu$ A at the minimum expected  $V_{CC}$  is generally sufficient. Even at maximum  $V_{CC}$ , this value only contributes a few milliwatts of power dissipation during standby.

$R_{LIM}$  limits the maximum current during transients. A value of a few hundred ohms is sufficient. When the ADP8140 is active, the additional worst case power dissipation from this limit circuitry is given by

$$\Delta P_{DISS(ACTIVE)} = (V_{CC(MAX)} - V_{Z(MIN)} + 0.7 \text{ V}) \times I_Q = (48 \text{ V} - 24 \text{ V} + 0.7 \text{ V}) \times 3 \text{ mA} = 74 \text{ mW}$$

## EFFECT OF LED $V_F$ MISMATCH

The ADP8140 always controls the FB\_OUT pin to regulate the output voltage to provide the minimum amount of headroom voltage required for the current sinks. One of the current sinks is regulated to  $V_{EA(REF)}$ . Typically,  $V_{EA(REF)}$  is either 350 mV or 450 mV (see  $V_{EA(350)}$  and  $V_{EA(450)}$  in Table 1). The voltage seen on the other three SINKx pins varies based on the distribution of the LED forward voltage,  $V_F$ . For a given lot of LEDs, the  $V_F$  and the change in  $V_F$  with temperature is relatively consistent. Given a  $V_F$  distribution, the maximum voltage that appears on any of the SINKx pins can be statistically calculated. For example, consider a mean  $V_F$  of 3.5 V and a normal distribution with a standard deviation of 70 mV. A statistical analysis of such a distribution reveals the maximum voltage that may appear on any of the SINKx pins, as shown in Figure 30). Note that in Figure 30, the maximum value is defined as the average plus six standard deviations ( $\sigma$ ) of the distribution.

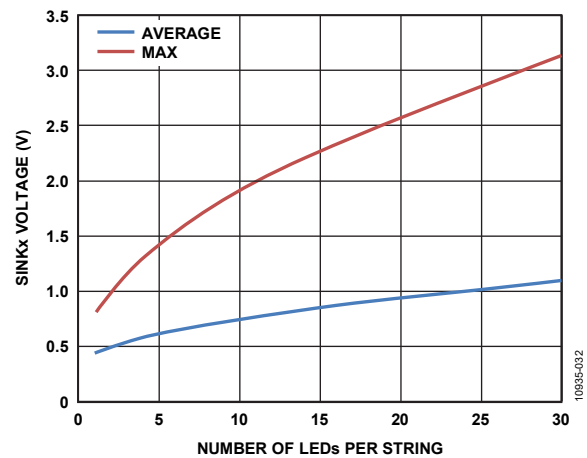

Figure 30. Voltage on SINKx Pins Given a Normal Distribution of  $V_F$ , Standard Deviation = 70 mV

The SINKx voltage found on each pin determines the power that the ADP8140 package must dissipate. Specifically, the ADP8140 power dissipation can be represented as follows:

$$P_{DISS} = (V_{SINK1} + V_{SINK2} + V_{SINK3} + V_{SINK4}) \times I_{LED} \quad (2)$$

A statistical analysis based on the  $V_F$  distribution of the LED can be performed to predict the total power dissipation within the ADP8140. For the same distribution used in Equation 2 and an LED current of 350 mA, Figure 31 gives the average and maximum power dissipations. Note that in Figure 31, the maximum value is defined as the average plus six standard deviations of the distribution.

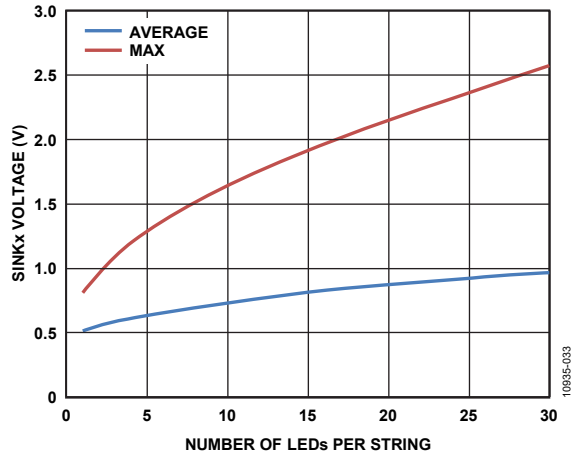

Figure 31. Total Power Dissipation (All Four Strings) for a Normal Distribution of  $V_f$ , Standard Deviation = 70 mV,  $I_{LED} = 350$  mA

## MANAGING THE POWER DISSIPATION OF THE ADP8140

With the predicted power dissipation known, the next step is to determine if the ADP8140 package is able to dissipate that power adequately. Use the following to calculate the maximum power that the ADP8140 is able to dissipate:

$$P_{DISS(MAX)} = (T_J - T_{BOARD})/\theta_{JB} \\ = (135 - 105)/12.4 = 2.4 \text{ W}$$

where:

$T_J = 135^\circ\text{C}$ , the maximum ADP8140 junction temperature (before entering thermal foldback).

$T_{BOARD} = 105^\circ\text{C}$ , the maximum board temperature.

$\theta_{JB} = 12.4^\circ\text{C/W}$  (see Table 3).

Assume that 100% of the power dissipates through the exposed pad to the board.

The ability of the ADP8140 package to dissipate heat varies if the operating conditions are not consistent with the  $\theta_{JB}$  conditions given in Table 3. Additionally, it is imperative to follow the layout guidelines given in the Layout Guidelines section.

## LAYOUT GUIDELINES

For optimum performance, follow these layout guidelines:

- The exposed pad of the ADP8140 must be properly connected to a heat sink. Solder the exposed pad to the PCB and connect it to a large plane of ground metal with an array of thermal vias.

- The ADP8140 is designed for easy layout with single sided metal core substrates. If FR4 substrate is used, thermal vias must be used between the LFCSP exposed pad and a large ground trace on the opposite side of the board.
- Place the REG capacitor close to the IC. The location of the VIN capacitor is not as important.
- Place the COMP capacitor(s) and resistor as close to the IC as possible.
- Place the VO\_SNS resistors (if used) close to the IC.
- If applying an analog dimming voltage to the DIM or VT pins, placing a bypass capacitor near these pins reduces the noise on these dimming signals.

## ORDERING OPTIONS

The ADP8140 is available in two options. The difference between the options is the  $V_{EA(REF)}$  voltage and the number of sinks that control the COMP and FB\_OUT voltage.

See Figure 33 to Figure 36 for examples of the ADP8140 used in various configurations: with a PMOS regulation stage, as a secondary controller, with a boost or buck power stage, or with one power stage.

### ADP8140ACPZ-1-R7

The ADP8140ACPZ-1-R7 has  $V_{EA(REF)}$  at 350 mV. Therefore, if using the device with the PMOS power stage or as a secondary side controller, each current sink can supply up to 350 mA of LED current at 350 mV of headroom voltage. However, if using the device to control an SMPS IC, each current sink can supply up to 500 mA of LED current.

The minimum voltage for all four of the current sinks is used to control the power regulation (COMP and FB\_OUT).

### ADP8140ACPZ-2-R7

The ADP8140ACPZ-2-R7 has  $V_{EA(REF)}$  at 450 mV. Therefore, all four of the sinks can be driven to 500 mA in any configuration.

Only the minimum voltage from SINK1, SINK2, and SINK3 is used to control the FB\_OUT and COMP pins. Therefore, this is the preferred device model if only three LED strings are used in a system. SINK4 can be left floating or connected to GND. Note that SINK4 is still enabled; if it is connected to an LED string, it regulates its current to be the same as the other sinks. Therefore, SINK4 can be combined with another SINKx pin (for example to drive two strings at 1 A each).





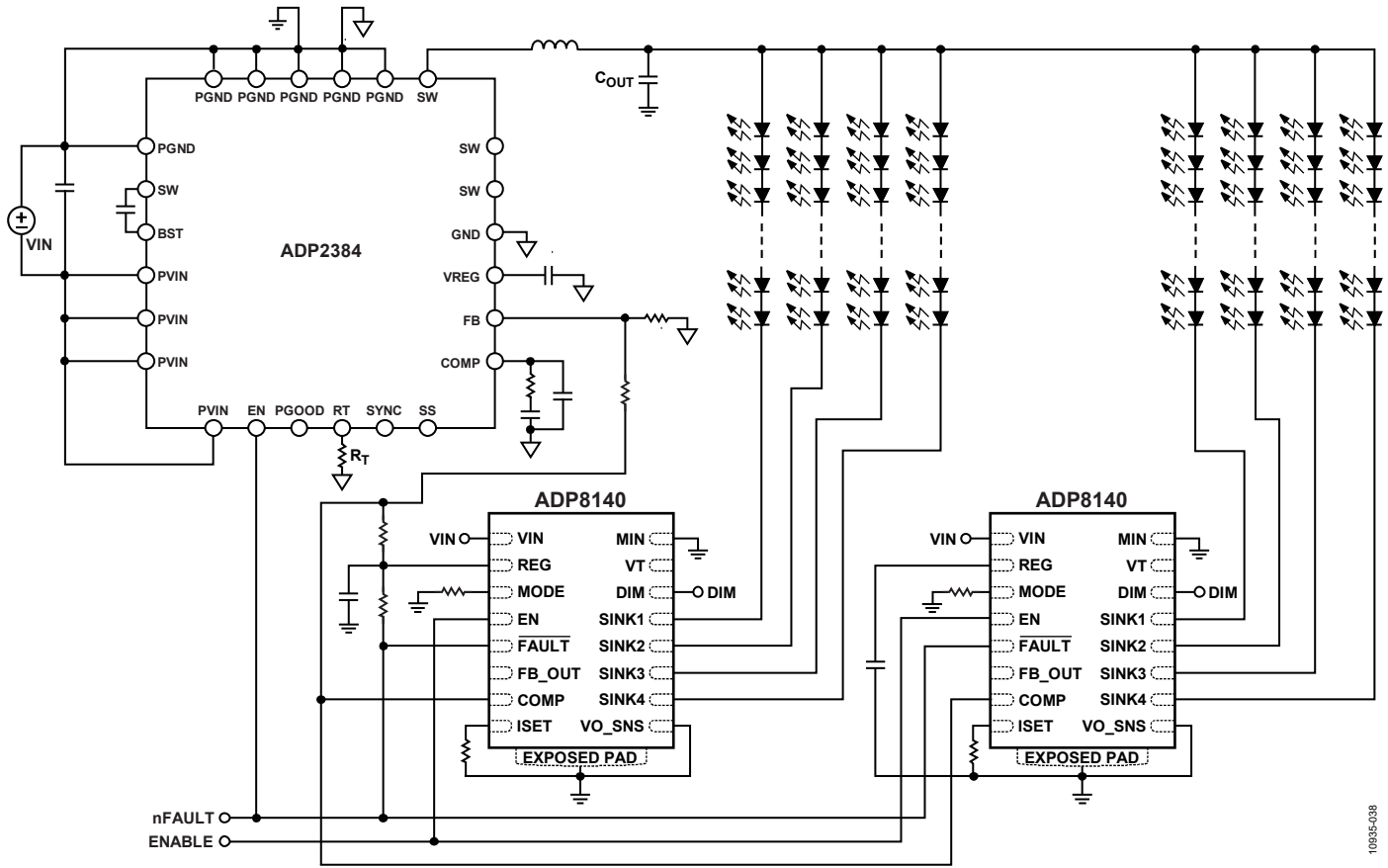
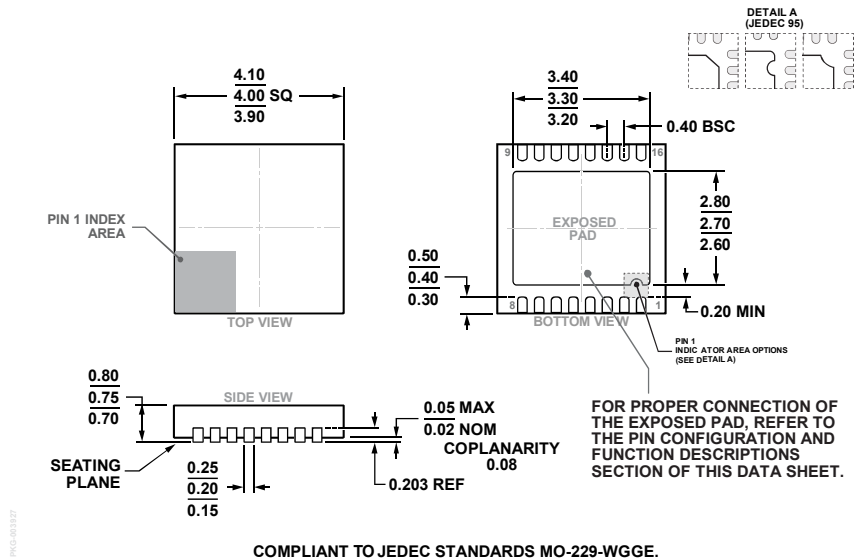

Figure 36. Multiple ADP8140 ICs with One Power Stage

10895-038

# OUTLINE DIMENSIONS



COMPLIANT TO JEDEC STANDARDS MO-229-WGGE.

Figure 37. 16-Lead Lead Frame Chip Scale Package [LFCSP]  
 4 mm × 4 mm Body and 0.75 mm Package Height  
 (CP-16-29)  
 Dimensions shown in millimeters

## ORDERING GUIDE

Model <sup>1,2,3</sup>	V <sub>EA(REF)</sub> (mV)	Temperature Range	Package Description	Package Option
ADP8140ACPZ-1-R7	350	-40°C to +125°C	16-Lead LFCSP, 7" Tape and Reel	CP-16-29
ADP8140ACPZ-2-R7	450	-40°C to +125°C	16-Lead LFCSP, 7" Tape and Reel	CP-16-29
ADP8140EB-EVALZ			ADP8140 PMOS Evaluation Board	
ADP8140CP-EVALZ			ADP8140EB-EVALZ with the LEDs and Heat Sink	

<sup>1</sup> Z = RoHS Compliant Part.

<sup>2</sup> ADP8140ACPZ-1-R7: SINK4 function is normal.

<sup>3</sup> ADP8140ACPZ-2-R7: SINK4 regulates current but does not control FB\_OUT and COMP.

## Looking for pricing, stock, or lifecycle information?

Click below to explore more details on WIN SOURCE:

- ⊖ [View ADP8140ACPZ-2-R7 on WIN SOURCE](#)
- ⊖ [Analog Devices Inc. Information](#)

## Optimize Your Supply Chain with WIN SOURCE Solutions

- ✓ Global Sourcing Solution
- ✓ Obsolete Management
- ✓ Cost Control Management
- ✓ Shortage Management
- ✓ Alternative Solution
- ✓ Excess Inventory Management