



**THE DATASHEET OF
TPS43061EVM-198**



Using the TPS43061 Boost Evaluation Module (EVM)

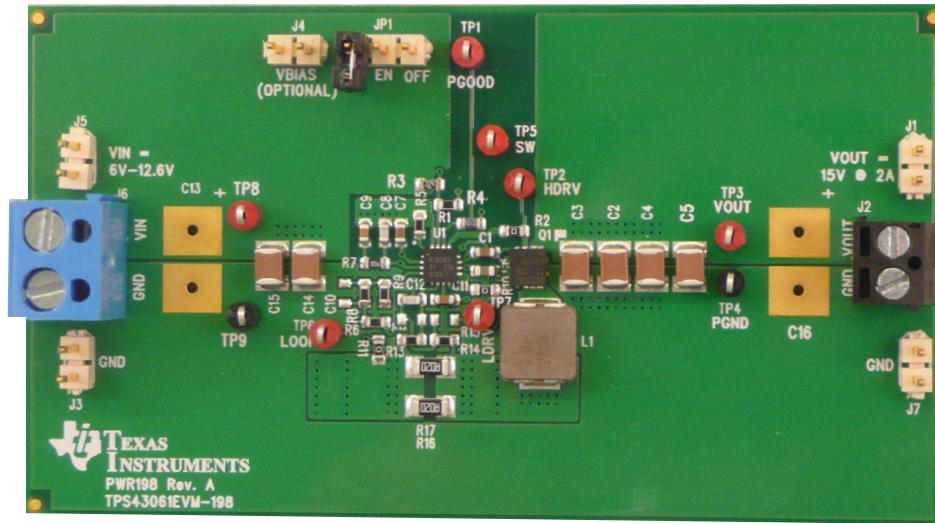

Figure 1. TPS43061EVM-198 EVM Board

This user's guide contains information for the TPS43061EVM-198 evaluation module (PWR198) including the performance specifications, schematic, and the bill of materials.

Contents

1	Introduction	3
2	Test Setup and Results	5
3	Schematic and Bill of Materials	11
4	Board Layout	13

List of Figures

1	TPS43061EVM-198 EVM Board	1
2	Efficiency Versus Load Current	6
3	Regulation Versus Output Current.....	7
4	Regulation Versus Input Voltage.....	7
5	Load Transient Response	7
6	Loop Response	7
7	Output Voltage Ripple CCM	8
8	Output Voltage Ripple DCM	8
9	Output Voltage Ripple Pulse Skip Mode.....	8
10	Input Voltage Ripple CCM	9
11	Input Voltage Ripple DCM	9
12	Start Up Relative to V_{IN}	9
13	Start Up Relative to EN	9
14	Shutdown Relative to V_{IN}	10

15	Shutdown Relative to EN	10
16	Gate-Drive Signals	10
17	TPS43061EVM-198 Schematic.....	11
18	TPS43061EVM-198 Top Assembly and Silkscreen	13
19	TPS43061EVM-198 Top-Side Layout	14
20	TPS43061EVM-198 Layer 2 Layout	14
21	TPS43061EVM-198 Layer 3 Layout	15
22	TPS43061EVM-198 Bottom-Side Layout	15

List of Tables

1	Input Voltage and Output Current Summary	3
2	TPS43061EVM-198 Performance Specification Summary	3
3	EVM Connectors and Test points.....	5
4	TPS43061EVM-198 Bill of Materials.....	12

1 Introduction

This user's guide contains background information for the TPS43061 as well as support documentation for the TPS43061EVM-198 evaluation module (PWR198). Also included are the performance specifications, schematic, and the bill of materials for the EVM.

1.1 Background

The TPS43061 is a DC-DC synchronous boost controller designed for a maximum output voltage of 60 V from an input voltage source of 4.5 V to 38 V. It has a 5.5-V gate-drive supply optimized for use with low Qg NexFETs. Rated input voltage and output current range for the evaluation module are given in [Table 1](#). This evaluation module is designed to demonstrate the small, printed-circuit-board areas that are possible when designing with the TPS43061 controller. The switching frequency is externally set at a nominal 750 kHz. The gate-drive circuitry for the external high-side and low-side FET is incorporated inside the TPS43061 package. The PWR198 uses the CSD86330Q3D NexFET power block integrating both the high-side and low-side FETs. External inductor DCR or resistor current sensing allows for an adjustable cycle-by-cycle current limit. The compensation components are external to the integrated circuit (IC), and an external resistor divider allows for an adjustable output voltage. Additionally, the TPS43061 provides an adjustable undervoltage lockout with hysteresis through an external resistor divider, adjustable slow-start time with an external capacitor and a power good output voltage indicator. The absolute maximum input voltage for the PWR198 based on the selected external components is 25 V.

Table 1. Input Voltage and Output Current Summary

EVM	Input Voltage Range	Output Current Range
TPS43061EVM-198	$V_{IN} = 6 \text{ V to } 12.6 \text{ V}$	$I_{OUT} = 0 \text{ A to } 2 \text{ A}$

1.2 Performance Specification Summary

A summary of the EVM performance specifications is provided in [Table 2](#). Specifications are given for an input voltage of $V_{IN} = 9 \text{ V}$ and an output voltage of 15 V, unless otherwise specified. This EVM is designed and tested for $V_{IN} = 6 \text{ V to } 12.6 \text{ V}$. The ambient temperature is 25°C for all measurements, unless otherwise noted.

Table 2. TPS43061EVM-198 Performance Specification Summary

Specification	Test Conditions	MIN	TYP	MAX	Unit	
V_{IN} voltage range		6	9	12.6	V	
Output voltage set point			15		V	
Output current range	$V_{IN} = 6 \text{ V to } 12.6 \text{ V}$	0		2	A	
Line regulation	$I_{OUT} = 2 \text{ A}, V_{IN} = 6 \text{ V to } 12.6 \text{ V}$		±0.1%			
Load regulation	$V_{IN} = 9 \text{ V}, I_{OUT} = 0.001 \text{ A to } 2 \text{ A}$		±0.1%			
Load transient response	$I_{OUT} = 0.5 \text{ A to } 1.5 \text{ A}$	Voltage change	-300		mV	
		Recovery time	400		µs	
	$I_{OUT} = 1.5 \text{ A to } 0.5 \text{ A}$	Voltage change		210		mV
		Recovery time		400		µs
Loop bandwidth	$V_{IN} = 9 \text{ V}, I_{OUT} = 2 \text{ A}$		19		kHz	
Phase margin	$V_{IN} = 9 \text{ V}, I_{OUT} = 2 \text{ A}$		68		°	
Input voltage ripple	$I_{OUT} = 2 \text{ A}$		10		mVpp	
Output voltage ripple	$I_{OUT} = 2 \text{ A}$		70		mVpp	
Output rise time			25		ms	
Operating frequency			750		kHz	

Table 2. TPS43061EVM-198 Performance Specification Summary (continued)

Specification	Test Conditions	MIN	TYP	MAX	Unit
Peak efficiency	TPS43061EVM-198, $V_{IN} = 12\text{ V}$, $I_{OUT} = 2\text{ A}$		97%		
DCM threshold	$V_{IN} = 9\text{ V}$		360		mA
Pulse skipping threshold	$V_{IN} = 9\text{ V}$		12		mA
No load input current	$V_{IN} = 9\text{ V}$		1.3		mA
UVLO start threshold			5.3		V
UVLO stop threshold			4.3		V

1.3 Modifications

These EVMs are designed to provide access to the features of the TPS43061. Some modifications can be made to this module. For further details please see the product data sheet.

1.3.1 Output Voltage Set Point

To change the output voltage of the EVM, it is necessary to change the value of resistor R8. The value of R8 for a specific output voltage can be calculated using [Equation 1](#), where R_{HS} is R8, R_{LS} is R9 and V_{FB} is 1.22 V. It is recommended to use a value of R9 near 10 k Ω .

$$R_{HS} = R_{LS} \times \frac{V_{OUT} - V_{FB}}{V_{FB}} \quad (1)$$

Note: V_{IN} must be in a range so the minimum on-time is greater than the typical 100 ns and the minimum off-time is greater than the largest of typical 250 ns and 5% of the switching period.

1.3.2 Current Sensing

The default configuration of the EVM is for resistor current sensing. R13 and R14 are populated with R15 open. When adjusting the input voltage, output voltage or desired maximum output voltage, the current sense resistors R16 and R17 may need to be adjusted. The peak inductor current should first be calculated with [Equation 2](#). [Equation 3](#) is then used to calculate the required current sense resistor where $V_{CS\text{typ}}$ is the current sense threshold. $V_{CS\text{typ}}$ should be determined from the TPS43061 data sheet with the maximum duty cycle in the application. Ensure the current sense resistor is rated for the expected power dissipation. For inductor DCR current sensing, R14 should be left open while R15, R16 and R17 are shorted.

$$I_{L\text{peak}} = \frac{I_{OUT}}{1 - \frac{V_{OUT} - V_{IN\text{min}}}{V_{OUT}}} + \frac{V_{IN\text{min}} \times \frac{V_{OUT} - V_{IN\text{min}}}{V_{OUT}}}{2 \times L \times f_{SW}} \quad (2)$$

$$R_{CS} = \frac{V_{CS\text{typ}}}{1.2 \times I_{L\text{peak}}} \quad (3)$$

1.3.3 Slow-Start Time

Adjust the slow-start time by changing the value of C7. [Equation 4](#) can be used to calculate the required capacitance based on a desired slow-start time, t_{SS} . I_{SS} is the charging current of 5- μA typical and V_{REF} is the internal reference voltage of 1.22 V. The EVM is set for a slow-start time of 25 ms using $C7 = 0.1\text{ }\mu\text{F}$.

$$C_{SS} = \frac{t_{SS} \times I_{SS}}{V_{REF}} \quad (4)$$

1.3.4 Adjustable UVLO

The undervoltage lockout (UVLO) can be adjusted externally using R3 and R4. The EVM is set for a start voltage of 5.34 V and stop voltage of 4.31 V using R3 = 221 kΩ and R4 = 59.0 kΩ. Use [Equation 5](#) and [Equation 6](#) to calculate the required resistor values for R3 and R4 respectively for different start and stop voltages. The typical values of the constants in the two equations are as follows: $V_{EN_DIS} = 1.14$ V, $V_{EN_ON} = 1.21$ V, $I_{EN_pup} = 1.8$ μA, and $I_{EN_hys} = 3.2$ μA.

$$R_{UVLO_H} = \frac{V_{START} \times \left(\frac{V_{EN_DIS}}{V_{EN_ON}} \right) - V_{STOP}}{I_{EN_pup} \times \left(1 - \frac{V_{EN_DIS}}{V_{EN_ON}} \right) + I_{EN_hys}} \quad (5)$$

$$R_{UVLO_L} = \frac{R_{UVLO_H} \times V_{EN_DIS}}{V_{STOP} - V_{EN_DIS} + R_{UVLO_H} \times (I_{EN_pup} + I_{EN_hys})} \quad (6)$$

1.3.5 Input Voltage Rails

The EVM is designed to accommodate different input voltage levels for the power stage and control logic. During normal operation, the VIN inputs are the same with R11 shorted. The single input voltage is supplied to J6. If desired, the two input voltage rails may be separated by removing R11. The control logic input voltage can be supplied to J4 and the power stage input voltage to J6.

1.3.6 Further Modification

Be aware, changing the input and output of conditions of the EVM will impact the design. It may also be necessary to modify the inductor, output capacitor and compensation components for the desired performance in the application. Additionally the CSD86330Q3D power block limits the output voltage to a maximum recommend output voltage of 22 V. Please see the data sheet or the excel design spreadsheet located in the product folder for details.

2 Test Setup and Results

This section describes how to properly connect, set up, and use the EVM. The section also includes test results typical for the EVM covering efficiency, output voltage regulation, load transients, loop response, output ripple, input ripple, start up and shutdown.

2.1 Input/Output Connections

This EVM includes input/output connectors and test points as shown in [Table 3](#). A power supply capable of supplying at least 6 A must be connected to J6 through a pair of 20-AWG wires. The load must be connected to J2 through a pair of 20-AWG wires. The maximum load-current capability must be 2 A. Wire lengths must be minimized to reduce losses in the wires. If any modification is done to the EVM design, an input supply and load rated for the new design are required. Test point TP8 provides a place to monitor the V_{IN} input voltages with TP9 providing a convenient ground reference. TP3 is used to monitor the output voltage with TP4 as the ground reference.

Table 3. EVM Connectors and Test points

Reference Designator	Function
J1	2-pin header for V_{OUT} voltage connections
J2	V_{OUT} , 15 V at 2-A maximum
J3	2-pin header for GND connections
J4	2-pin header for optional V_{BIAS} input voltage connections (see Section 1.3.5)
J5	2-pin header for V_{IN} input voltage connections
J6	V_{IN} (see Table 1 for V_{IN} range)
J7	2-pin header for GND connections
JP1	3-pin header for EN jumper. Install jumper from pins 1-2 to enable or pins 2-3 to disable.

Table 3. EVM Connectors and Test points (continued)

Reference Designator	Function
TP1	PGOOD test point for power good output voltage indicator
TP2	HDRV test point for high-side gate-drive voltage
TP3	V_{OUT} test point at V_{OUT} connector
TP4	GND test point at V_{OUT} connector
TP5	SW test point for switch node voltage
TP6	Test point between voltage divider network and output used for loop response measurements.
TP7	LDRV test point for low-side gate-drive voltage
TP8	V_{IN} test point at V_{IN} connector
TP9	GND test point at V_{IN}

2.2 Efficiency

The efficiency of this EVM peaks at a load current of about 2 A with $V_{IN} = 12$ V, and then decreases as the load current increases towards maximum load. Figure 2 shows the efficiency for the EVM brought to current limit for each input voltage. Dotted-line efficiency data was measured with Würth Elektronik 744311330. Measurements are taken at ambient temperature of 25°C. The efficiency may be lower at higher ambient temperatures due to temperature variation in the drain-to-source resistance of the selected external MOSFETs.

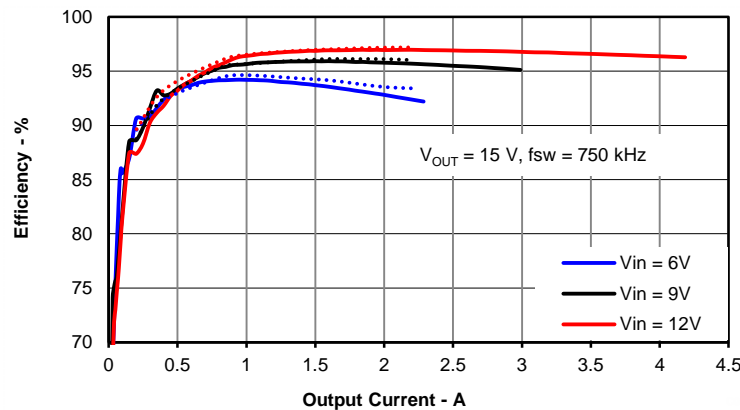
Figure 2. Efficiency Versus Load Current

2.3 Output Voltage Regulation

The load regulation for the EVM is shown in Figure 3. The line regulation for the EVM is shown in Figure 4. Measurements are given for an ambient temperature of 25°C.

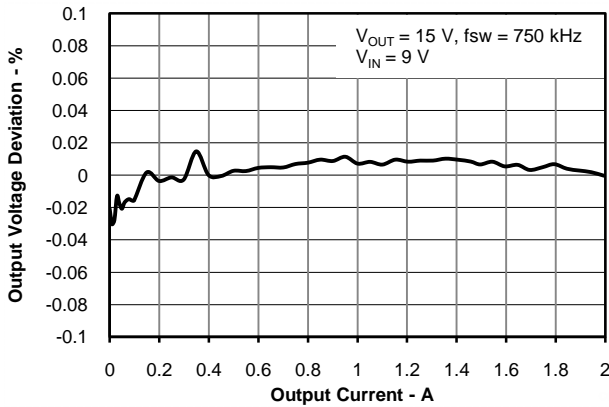

Figure 3. Regulation Versus Output Current

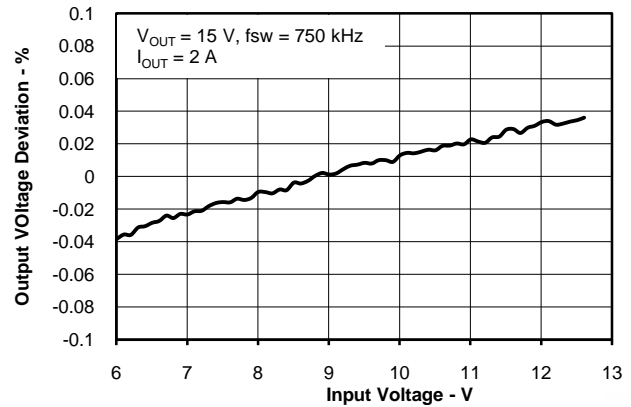

Figure 4. Regulation Versus Input Voltage

2.4 Load Transients and Loop Response

The EVM response to load transients is shown in Figure 5. The current step is from 25% to 75% of maximum rated load at 9 V input. The current step-slew rate is 100 mA/μs. Total peak-to-peak voltage variation is as shown, including ripple and noise on the output.

The EVM loop-response characteristics are shown in Figure 6. Gain and phase plots are shown for V_{IN} voltage of 9 V. Load current for the measurement is 2 A.

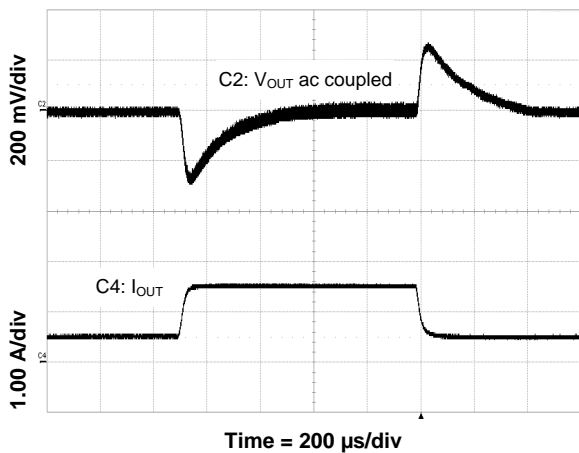

Figure 5. Load Transient Response

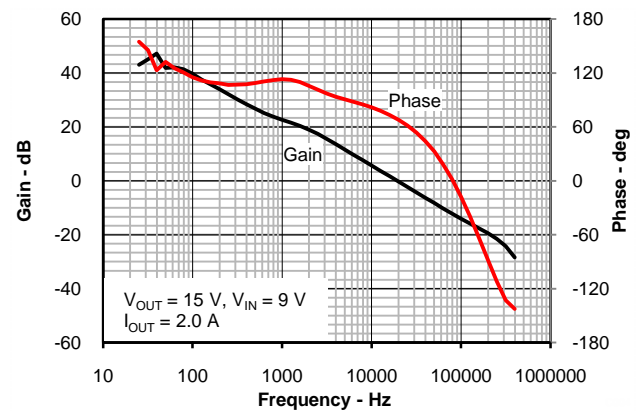

Figure 6. Loop Response

2.5 Output Voltage Ripple

The EVM continuous conduction mode (CCM) output voltage ripple is shown in Figure 7. The output current is the rated full load of 2 A and $V_{IN} = 9\text{ V}$. The voltage ripple is measured directly across the output capacitors.

The discontinuous conduction mode (DCM) output voltage ripple is shown in Figure 8. The output current is 0.15 A and $V_{IN} = 9\text{ V}$.

The pulse skip mode output voltage ripple is shown in Figure 9. There is no external load on the output and $V_{IN} = 9\text{ V}$.

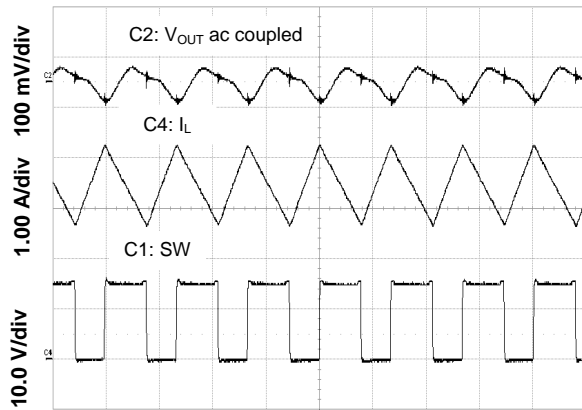

Time = 1.00 μs/div
Figure 7. Output Voltage Ripple CCM

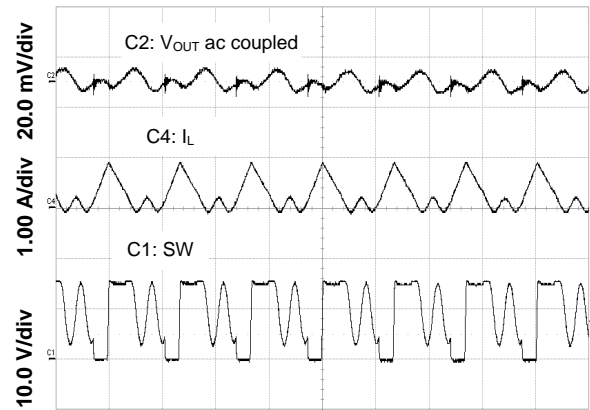

Time = 1.00 μs/div
Figure 8. Output Voltage Ripple DCM

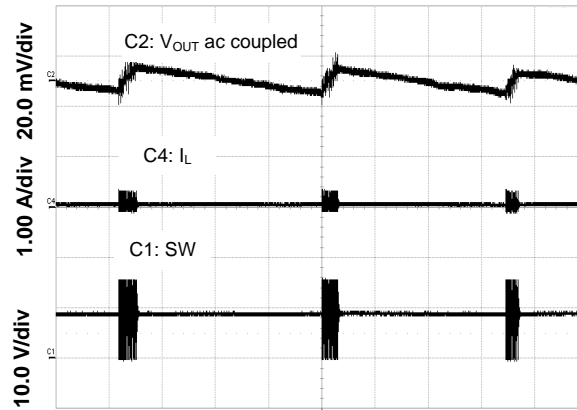

Time = 500 μs/div
Figure 9. Output Voltage Ripple Pulse Skip Mode

2.6 Input Voltage Ripple

The EVM CCM input voltage ripple is shown in Figure 10. The output current is the rated full load of 2 A and $V_{IN} = 9$ V. The voltage ripple is measured directly across the input capacitors.

The DCM input voltage ripple is shown in Figure 11. The output current is 0.15 A and $V_{IN} = 9$ V.

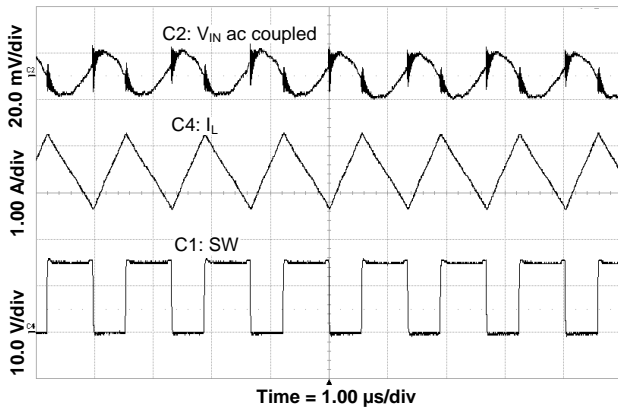

Figure 10. Input Voltage Ripple CCM

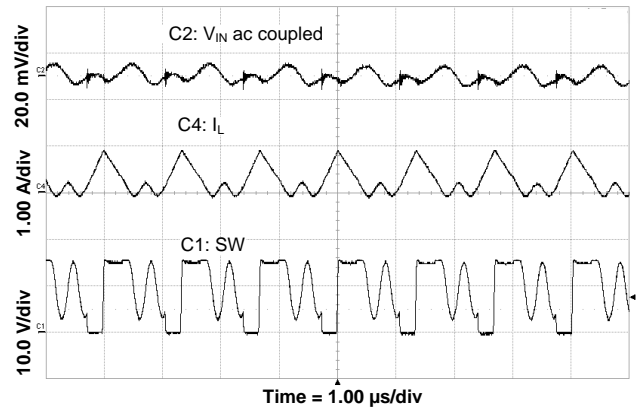

Figure 11. Input Voltage Ripple DCM

2.7 Start Up

The start up waveforms are shown in Figure 12 and Figure 13. The input voltage for these plots is 9 V and the output has a 2-A resistive load. In Figure 12 the input voltage supply is turned on and V_{IN} begins rising. Both the VCC and VOUT rail initially rise with V_{IN} . When the input reaches the undervoltage lockout threshold set by the external resistor divider, the device can begin switching and the output ramps up to the set value of 15 V with the slow-start voltage. PGOOD goes high when VOUT is in regulation.

In Figure 13 the input voltage is applied with EN held low. The output voltage is a diode drop below the input voltage and VCC is disabled. When EN is released, the start up sequence begins with VCC coming into regulation and the output ramps up to the set value of 15 V. PGOOD goes high when VOUT is in regulation.

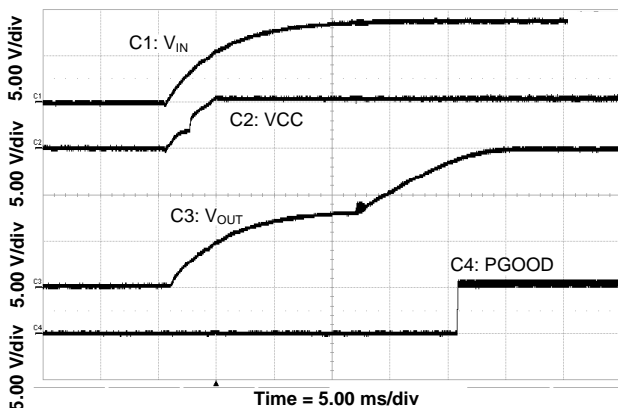

Figure 12. Start Up Relative to V_{IN}

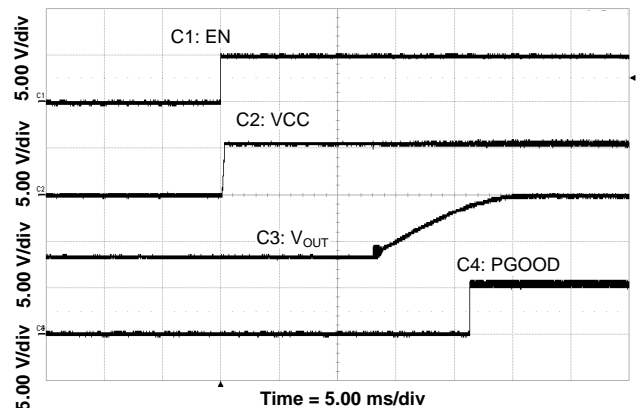

Figure 13. Start Up Relative to EN

2.8 Shutdown

The shutdown waveforms are shown in [Figure 14](#) and [Figure 15](#). In [Figure 14](#) the input voltage is removed, and when the input falls below the undervoltage lockout threshold set by the EN resistor divider, the TPS43061 shuts down, PGOOD is pulled low and the output falls to ground. The output has a 2-A resistive load.

In [Figure 15](#) the input voltage is held at 9 V with no load and EN is shorted to ground. When EN is grounded, the TPS43061 is disabled, PGOOD is pulled low and the output voltage discharges to V_{IN} .

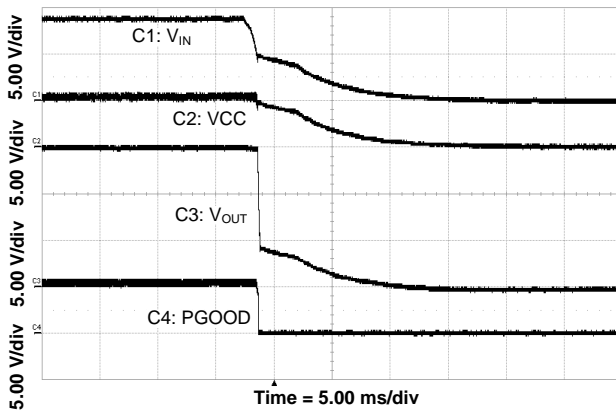

Figure 14. Shutdown Relative to V_{IN}

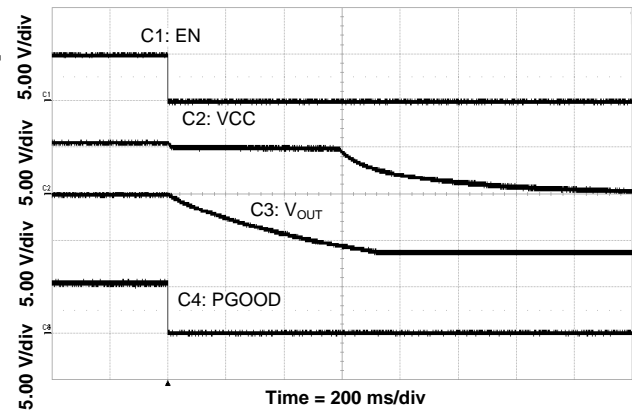

Figure 15. Shutdown Relative to EN

2.9 Gate-Drive Signals

In [Figure 16](#) the gate-drive signals for the high-side and low-side FETs can be seen with the switching node are shown. The input voltage is 9 V and the output has a 2-A load.

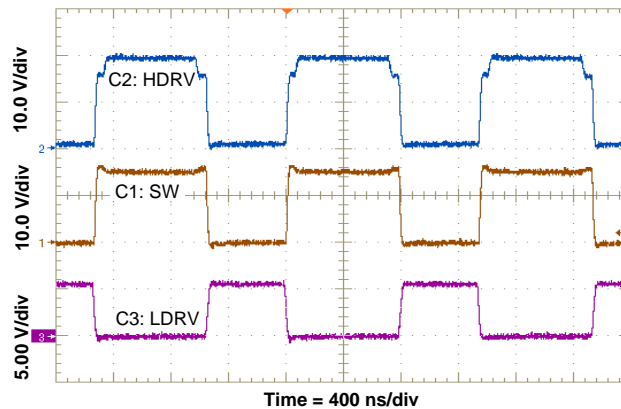

Figure 16. Gate-Drive Signals

3 Schematic and Bill of Materials

This section presents the EVM schematic and bill of materials.

3.1 Schematic

Figure 17 is the schematic for the EVM.

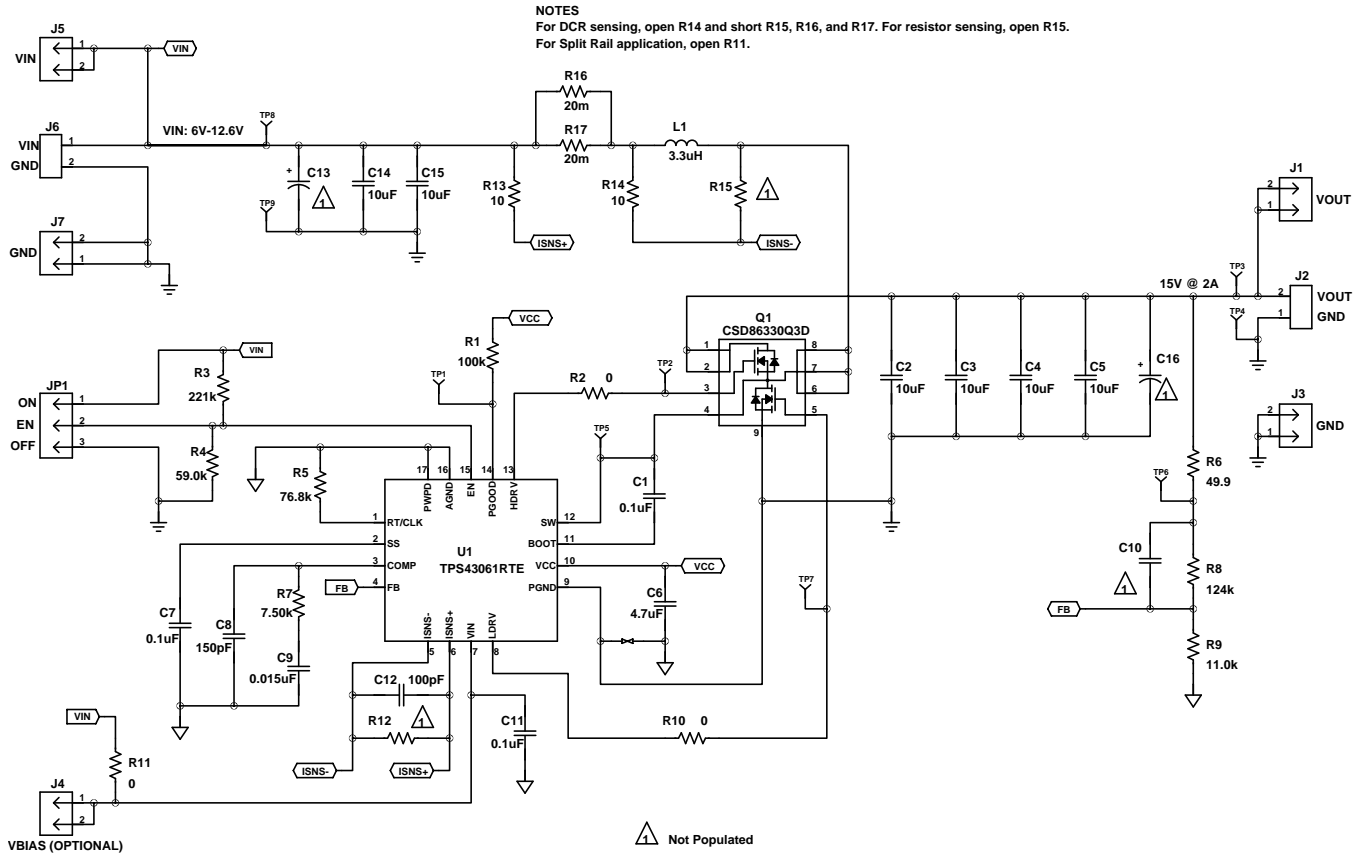

Figure 17. TPS43061EVM-198 Schematic

3.2 Bill of Materials

Table 4 presents the bill of materials for the EVM.

Table 4. TPS43061EVM-198 Bill of Materials

Qty	RefDes	Value	Description	Size	Part Number	MFR
1	C6	4.7uF	Capacitor, Ceramic, 16V, X5R, 10%	0603	STD	STD
1	C8	150pF	Capacitor, Ceramic, 50V, COG, 5%	0603	STD	STD
1	C9	0.015uF	Capacitor, Ceramic, 50V, X7R, 10%	0603	STD	STD
0	C10	Open	Capacitor, Ceramic, 10V, X7R, 10%	0603	STD	STD
1	C12	100pF	Capacitor, Ceramic, 25V, X7R, 20%	0603	STD	STD
3	C1 C7 C11	0.1uF	Capacitor, Ceramic, 25V, X7R, 10%	0603	STD	STD
5	C2-5 C14-15	10uF	Capacitor, Ceramic Chip, 25V, X5R, 10%	1210	STD	STD
0	C13 C16	Open	Capacitor	Multi sizes	Engineering Only	STD
5	J1 J3-5 J7	PEC02SAAN	Header, Male 2-pin, 100mil spacing	0.100 inch x 2	PEC02SAAN	Sullins
1	J2	ED555/2DS	Terminal Block, 2-pin, 6-A, 3.5mm	0.27 x 0.25 inch	ED555/2DS	OST
1	J6	ED120/2DS	Terminal Block, 2-pin, 15-A, 5.1mm	0.40 x 0.35 inch	ED120/2DS	OST
1	JP1	PEC03SAAN	Header, Male 3-pin, 100mil spacing	0.100 inch x 3	PEC03SAAN	Sullins
1	L1	3.3uH	Inductor, SMT, 6.0A, 30-milliohm	0.255 x 0.270 inch	IHLP2525CZER3R3M01 or 744311330	Vishay Würth Elektronik
1	Q1	CSD86330Q3D	MOSFET, Synchronous Buck NexFET Power Block	QFN-8 POWER	CSD86330Q3D	TI
1	R1	100k	Resistor, Chip, 1/16W, 1%	0603	STD	STD
1	R3	221k	Resistor, Chip, 1/16W, 1%	0603	STD	STD
1	R4	59.0k	Resistor, Chip, 1/16W, 1%	0603	STD	STD
1	R5	76.8k	Resistor, Chip, 1/16W, 1%	0603	STD	STD
1	R6	49.9	Resistor, Chip, 1/16W, 1%	0603	STD	STD
1	R7	7.50k	Resistor, Chip, 1/16W, 1%	0603	STD	STD
1	R8	124k	Resistor, Chip, 1/16W, 1%	0603	STD	STD
1	R9	11.0k	Resistor, Chip, 1/16W, 1%	0603	STD	STD
0	R12 R15	Open	Resistor, Chip, 1/16W, 1%	0603	STD	STD
2	R13-14	10	Resistor, Chip, 1/16W, 1%	0603	STD	STD
2	R16-17	20m	Resistor, Chip, 1/2W, 1%, 100ppm	1206	PF1206FRF070R02L	Yageo
3	R2 R10-11	0	Resistor, Chip, 1/16W, 1%	0603	STD	STD
1	SH1		Short jumper, 100mil	0.100 inch	929950-00	3M
2	TP4 TP9	5001	Test Point, Black, Thru Hole Color Keyed	0.100 x 0.100 inch	5001	Keystone
7	TP1-3 TP5-8	5000	Test Point, Red, Thru Hole Color Keyed	0.100 x 0.100 inch	5000	Keystone
1	U1	TPS43061RTE	IC, Wide VIN Current Mode Synchronous Boost Controller	VQFN	TPS43061RTE	TI
1	--		PCB, 3.2 In x 1.8 In x 0.062 In		PWR198	Any
Notes:						
1. These assemblies are ESD sensitive, ESD precautions shall be observed.						
2. These assemblies must be clean and free from flux and all contaminants.						
Use of no clean flux is not acceptable.						
3. These assemblies must comply with workmanship standards IPC-A-610 Class 2.						
4. Ref designators marked with an asterisk (***) cannot be substituted.						
All other components can be substituted with equivalent MFG's components.						

4 Board Layout

This section provides a description of the EVM, board layout, and layer illustrations.

4.1 Layout

The board layout for the EVM is shown in Figure 18 through Figure 22. This design has 4 layers of 2-oz copper.

The top layer contains the main power traces for V_{IN} , V_{OUT} , and SW. Also on the top layer are all other components to allow the user to easily view, probe, and evaluate the TPS43061 control IC. The remaining area is filled with ground. The remaining three layers have additional copper for VIN, VOUT, AGND, and PGND connected with multiple vias. Additional copper is also connected to the sense resistor to aid with thermal dissipation. The second internal layer and bottom layer contain signal routes. Five vias directly under the TPS43061 device provide a thermal path from the top-side ground plane to the bottom-side and internal AGND plane. Lastly, the layout guidelines should be followed for the CSD86330Q3D which includes 12 vias beneath the device to the internal and bottom PGND planes to aid with thermal dissipation.

All noise-sensitive analog circuitry are placed as close as possible to the IC. The voltage divider network ties to the output voltage at the point of regulation on the bottom layer, near the output capacitors. Q1 is also placed as close as possible to the IC to keep the gate-drive traces as short as possible. The output capacitors are placed next to Q1 to limit the length of the high frequency switching current path. The SW copper is kept as small as possible to limit radiated noise from the high-frequency switching voltage node. The power pad is connected to the AGND pin and all noise-sensitive circuitry must use this as the ground return path. The ground return for the power components are connected to the PGND pin. The AGND and PGND are connected at one point near the PGND pin. The bypass capacitors for VIN and VCC are placed next to their respective pins. The filter capacitor between ISNS+ and ISNS- is located next to the pins to help filter out switching noise. An additional input bulk capacitor may be required (C13) depending on the connection to the EVM from the input supply. See the product datasheet for all layout recommendations.

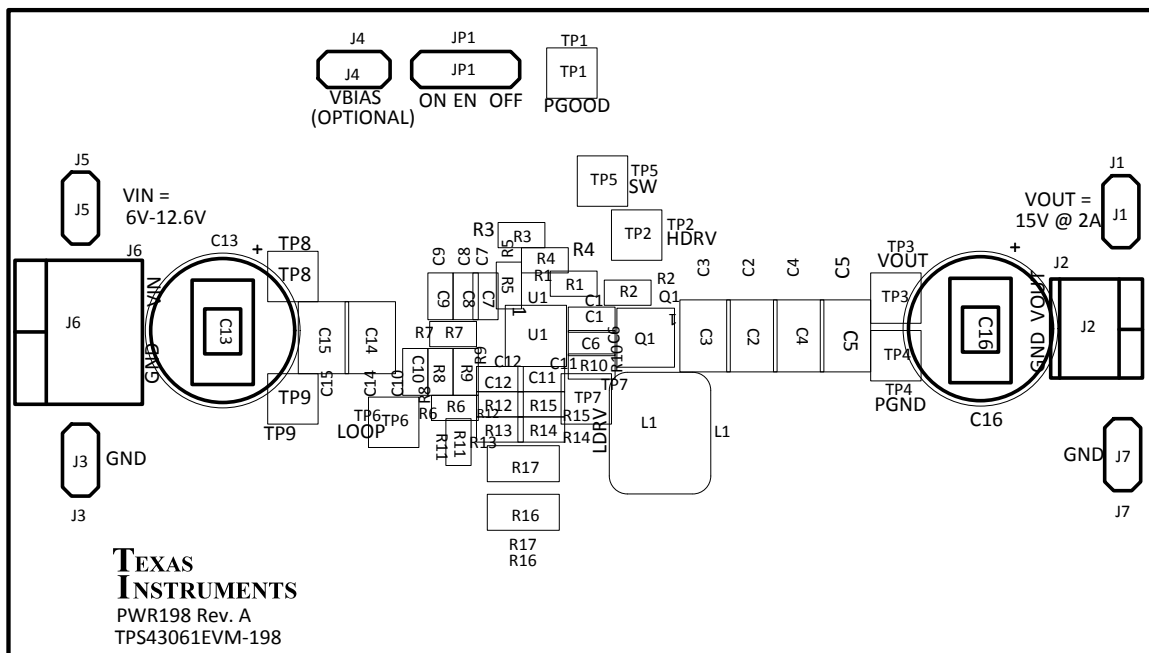

Figure 18. TPS43061EVM-198 Top Assembly and Silkscreen

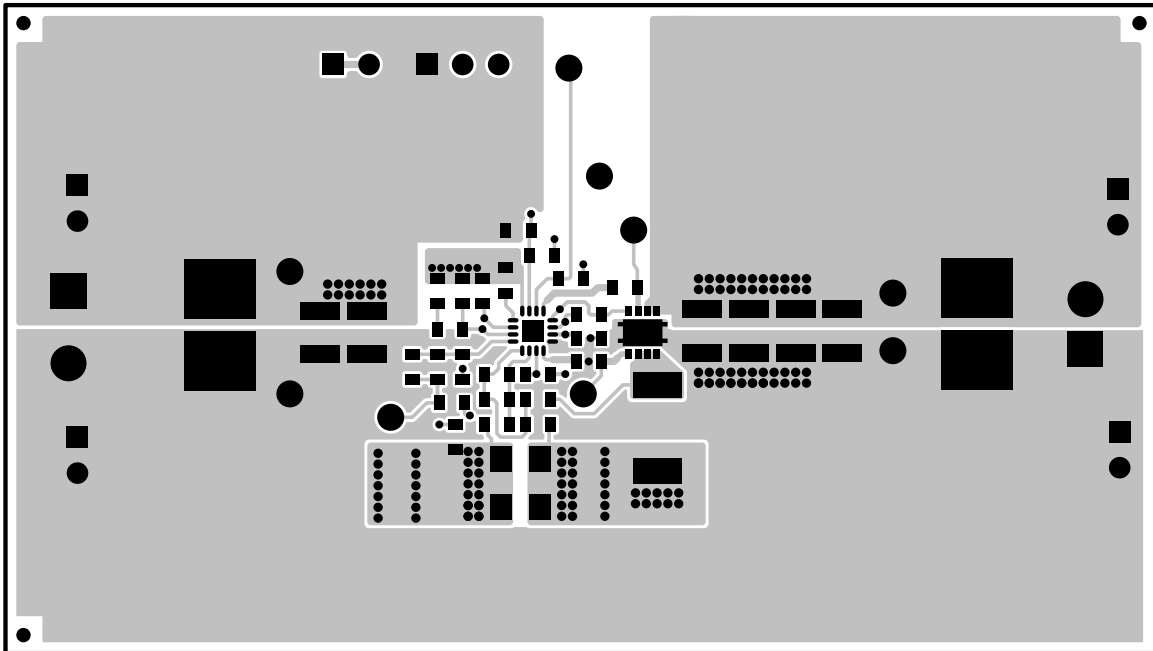

Figure 19. TPS43061EVM-198 Top-Side Layout

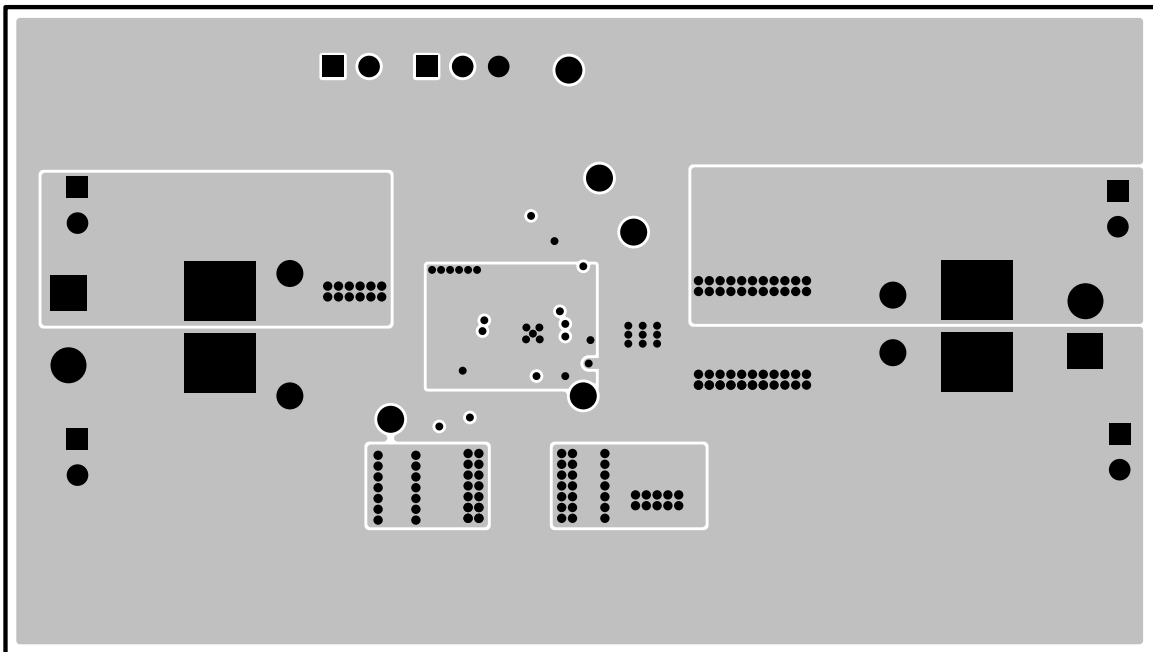

Figure 20. TPS43061EVM-198 Layer 2 Layout

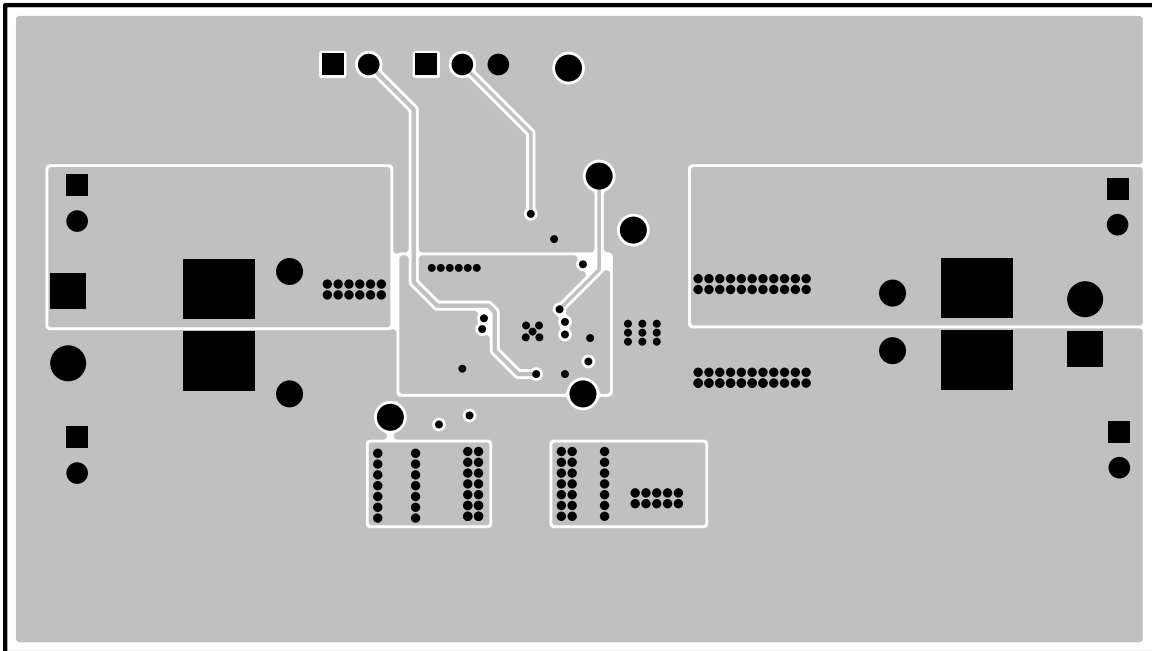

Figure 21. TPS43061EVM-198 Layer 3 Layout

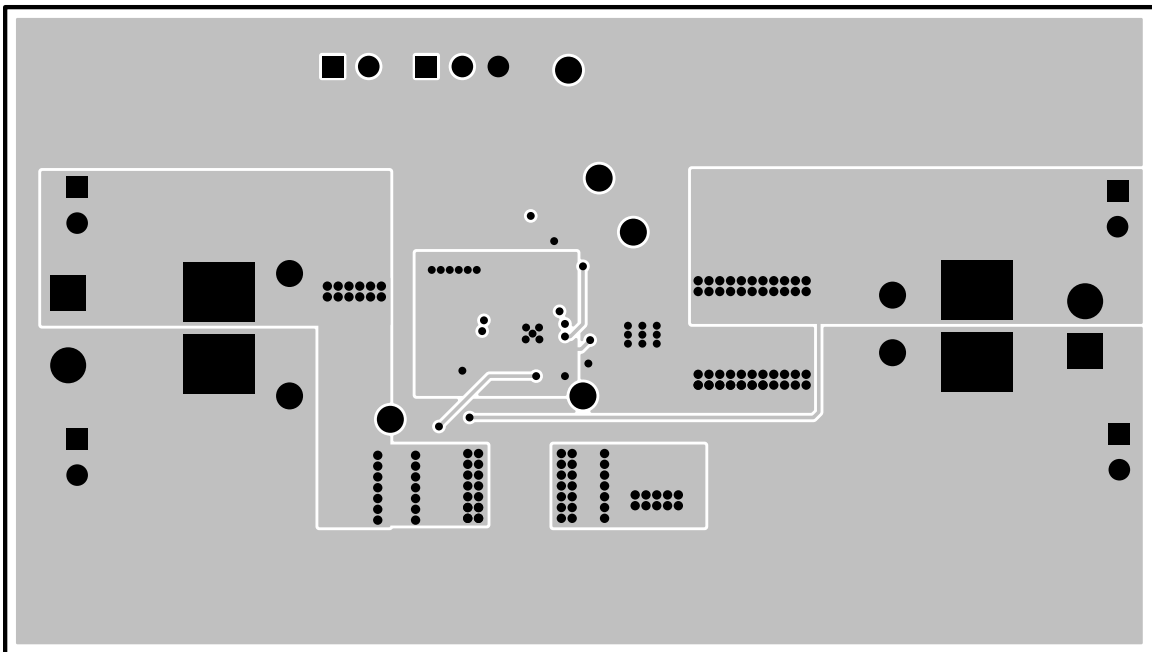

Figure 22. TPS43061EVM-198 Bottom-Side Layout

4.2 Estimated Circuit Area

The estimated printed-circuit-board area by outlining the components used in this design and the routing between them is 0.91 in² (590 mm²). This area does not include test points or connectors. Also note, this design uses 0603 components for easy modifications and places all components on one layer so this area may be reduced.

EVALUATION BOARD/KIT/MODULE (EVM) ADDITIONAL TERMS

Texas Instruments (TI) provides the enclosed Evaluation Board/Kit/Module (EVM) under the following conditions:

The user assumes all responsibility and liability for proper and safe handling of the goods. Further, the user indemnifies TI from all claims arising from the handling or use of the goods.

Should this evaluation board/kit not meet the specifications indicated in the User's Guide, the board/kit may be returned within 30 days from the date of delivery for a full refund. THE FOREGOING LIMITED WARRANTY IS THE EXCLUSIVE WARRANTY MADE BY SELLER TO BUYER AND IS IN LIEU OF ALL OTHER WARRANTIES, EXPRESSED, IMPLIED, OR STATUTORY, INCLUDING ANY WARRANTY OF MERCHANTABILITY OR FITNESS FOR ANY PARTICULAR PURPOSE. EXCEPT TO THE EXTENT OF THE INDEMNITY SET FORTH ABOVE, NEITHER PARTY SHALL BE LIABLE TO THE OTHER FOR ANY INDIRECT, SPECIAL, INCIDENTAL, OR CONSEQUENTIAL DAMAGES.

Please read the User's Guide and, specifically, the Warnings and Restrictions notice in the User's Guide prior to handling the product. This notice contains important safety information about temperatures and voltages. For additional information on TI's environmental and/or safety programs, please visit www.ti.com/esh or contact TI.

No license is granted under any patent right or other intellectual property right of TI covering or relating to any machine, process, or combination in which such TI products or services might be or are used. TI currently deals with a variety of customers for products, and therefore our arrangement with the user is not exclusive. TI assumes no liability for applications assistance, customer product design, software performance, or infringement of patents or services described herein.

REGULATORY COMPLIANCE INFORMATION

As noted in the EVM User's Guide and/or EVM itself, this EVM and/or accompanying hardware may or may not be subject to the Federal Communications Commission (FCC) and Industry Canada (IC) rules.

For EVMs **not** subject to the above rules, this evaluation board/kit/module is intended for use for ENGINEERING DEVELOPMENT, DEMONSTRATION OR EVALUATION PURPOSES ONLY and is not considered by TI to be a finished end product fit for general consumer use. It generates, uses, and can radiate radio frequency energy and has not been tested for compliance with the limits of computing devices pursuant to part 15 of FCC or ICES-003 rules, which are designed to provide reasonable protection against radio frequency interference. Operation of the equipment may cause interference with radio communications, in which case the user at his own expense will be required to take whatever measures may be required to correct this interference.

General Statement for EVMs including a radio

User Power/Frequency Use Obligations: This radio is intended for development/professional use only in legally allocated frequency and power limits. Any use of radio frequencies and/or power availability of this EVM and its development application(s) must comply with local laws governing radio spectrum allocation and power limits for this evaluation module. It is the user's sole responsibility to only operate this radio in legally acceptable frequency space and within legally mandated power limitations. Any exceptions to this are strictly prohibited and unauthorized by Texas Instruments unless user has obtained appropriate experimental/development licenses from local regulatory authorities, which is responsibility of user including its acceptable authorization.

For EVMs annotated as FCC – FEDERAL COMMUNICATIONS COMMISSION Part 15 Compliant

Caution

This device complies with part 15 of the FCC Rules. Operation is subject to the following two conditions: (1) This device may not cause harmful interference, and (2) this device must accept any interference received, including interference that may cause undesired operation.

Changes or modifications not expressly approved by the party responsible for compliance could void the user's authority to operate the equipment.

FCC Interference Statement for Class A EVM devices

This equipment has been tested and found to comply with the limits for a Class A digital device, pursuant to part 15 of the FCC Rules. These limits are designed to provide reasonable protection against harmful interference when the equipment is operated in a commercial environment. This equipment generates, uses, and can radiate radio frequency energy and, if not installed and used in accordance with the instruction manual, may cause harmful interference to radio communications. Operation of this equipment in a residential area is likely to cause harmful interference in which case the user will be required to correct the interference at his own expense.

FCC Interference Statement for Class B EVM devices

This equipment has been tested and found to comply with the limits for a Class B digital device, pursuant to part 15 of the FCC Rules. These limits are designed to provide reasonable protection against harmful interference in a residential installation. This equipment generates, uses and can radiate radio frequency energy and, if not installed and used in accordance with the instructions, may cause harmful interference to radio communications. However, there is no guarantee that interference will not occur in a particular installation. If this equipment does cause harmful interference to radio or television reception, which can be determined by turning the equipment off and on, the user is encouraged to try to correct the interference by one or more of the following measures:

- Reorient or relocate the receiving antenna.
- Increase the separation between the equipment and receiver.
- Connect the equipment into an outlet on a circuit different from that to which the receiver is connected.
- Consult the dealer or an experienced radio/TV technician for help.

For EVMs annotated as IC – INDUSTRY CANADA Compliant

This Class A or B digital apparatus complies with Canadian ICES-003.

Changes or modifications not expressly approved by the party responsible for compliance could void the user's authority to operate the equipment.

Concerning EVMs including radio transmitters

This device complies with Industry Canada licence-exempt RSS standard(s). Operation is subject to the following two conditions: (1) this device may not cause interference, and (2) this device must accept any interference, including interference that may cause undesired operation of the device.

Concerning EVMs including detachable antennas

Under Industry Canada regulations, this radio transmitter may only operate using an antenna of a type and maximum (or lesser) gain approved for the transmitter by Industry Canada. To reduce potential radio interference to other users, the antenna type and its gain should be so chosen that the equivalent isotropically radiated power (e.i.r.p.) is not more than that necessary for successful communication.

This radio transmitter has been approved by Industry Canada to operate with the antenna types listed in the user guide with the maximum permissible gain and required antenna impedance for each antenna type indicated. Antenna types not included in this list, having a gain greater than the maximum gain indicated for that type, are strictly prohibited for use with this device.

Cet appareil numérique de la classe A ou B est conforme à la norme NMB-003 du Canada.

Les changements ou les modifications pas expressément approuvés par la partie responsable de la conformité ont pu vider l'autorité de l'utilisateur pour actionner l'équipement.

Concernant les EVMs avec appareils radio

Le présent appareil est conforme aux CNR d'Industrie Canada applicables aux appareils radio exempts de licence. L'exploitation est autorisée aux deux conditions suivantes : (1) l'appareil ne doit pas produire de brouillage, et (2) l'utilisateur de l'appareil doit accepter tout brouillage radioélectrique subi, même si le brouillage est susceptible d'en compromettre le fonctionnement.

Concernant les EVMs avec antennes détachables

Conformément à la réglementation d'Industrie Canada, le présent émetteur radio peut fonctionner avec une antenne d'un type et d'un gain maximal (ou inférieur) approuvé pour l'émetteur par Industrie Canada. Dans le but de réduire les risques de brouillage radioélectrique à l'intention des autres utilisateurs, il faut choisir le type d'antenne et son gain de sorte que la puissance isotrope rayonnée équivalente (p.i.r.e.) ne dépasse pas l'intensité nécessaire à l'établissement d'une communication satisfaisante.

Le présent émetteur radio a été approuvé par Industrie Canada pour fonctionner avec les types d'antenne énumérés dans le manuel d'usage et ayant un gain admissible maximal et l'impédance requise pour chaque type d'antenne. Les types d'antenne non inclus dans cette liste, ou dont le gain est supérieur au gain maximal indiqué, sont strictement interdits pour l'exploitation de l'émetteur.

【Important Notice for Users of this Product in Japan】

This development kit is NOT certified as Confirming to Technical Regulations of Radio Law of Japan

If you use this product in Japan, you are required by Radio Law of Japan to follow the instructions below with respect to this product:

1. Use this product in a shielded room or any other test facility as defined in the notification #173 issued by Ministry of Internal Affairs and Communications on March 28, 2006, based on Sub-section 1.1 of Article 6 of the Ministry's Rule for Enforcement of Radio Law of Japan,
2. Use this product only after you obtained the license of Test Radio Station as provided in Radio Law of Japan with respect to this product, or
3. Use of this product only after you obtained the Technical Regulations Conformity Certification as provided in Radio Law of Japan with respect to this product. Also, please do not transfer this product, unless you give the same notice above to the transferee. Please note that if you could not follow the instructions above, you will be subject to penalties of Radio Law of Japan.

Texas Instruments Japan Limited
(address) 24-1, Nishi-Shinjuku 6 chome, Shinjuku-ku, Tokyo, Japan

<http://www.tij.co.jp>

【ご使用にあたっての注】

本開発キットは技術基準適合証明を受けておりません。

本製品のご使用に際しては、電波法遵守のため、以下のいずれかの措置を取っていただく必要がありますのでご注意ください。

1. 電波法施行規則第6条第1項第1号に基づく平成18年3月28日総務省告示第173号で定められた電波暗室等の試験設備でご使用いただく。
2. 実験局の免許を取得後ご使用いただく。
3. 技術基準適合証明を取得後ご使用いただく。

なお、本製品は、上記の「ご使用にあたっての注意」を譲渡先、移転先に通知しない限り、譲渡、移転できないものとします。

上記を遵守頂けない場合は、電波法の罰則が適用される可能性があることをご留意ください。

日本テキサス・インスツルメンツ株式会社
東京都新宿区西新宿6丁目2-4番1号
西新宿三井ビル

<http://www.tij.co.jp>

EVALUATION BOARD/KIT/MODULE (EVM) WARNINGS, RESTRICTIONS AND DISCLAIMERS

For Feasibility Evaluation Only, in Laboratory/Development Environments. Unless otherwise indicated, this EVM is not a finished electrical equipment and not intended for consumer use. It is intended solely for use for preliminary feasibility evaluation in laboratory/development environments by technically qualified electronics experts who are familiar with the dangers and application risks associated with handling electrical mechanical components, systems and subsystems. It should not be used as all or part of a finished end product.

Your Sole Responsibility and Risk. You acknowledge, represent and agree that:

1. You have unique knowledge concerning Federal, State and local regulatory requirements (including but not limited to Food and Drug Administration regulations, if applicable) which relate to your products and which relate to your use (and/or that of your employees, affiliates, contractors or designees) of the EVM for evaluation, testing and other purposes.
2. You have full and exclusive responsibility to assure the safety and compliance of your products with all such laws and other applicable regulatory requirements, and also to assure the safety of any activities to be conducted by you and/or your employees, affiliates, contractors or designees, using the EVM. Further, you are responsible to assure that any interfaces (electronic and/or mechanical) between the EVM and any human body are designed with suitable isolation and means to safely limit accessible leakage currents to minimize the risk of electrical shock hazard.
3. You will employ reasonable safeguards to ensure that your use of the EVM will not result in any property damage, injury or death, even if the EVM should fail to perform as described or expected.
4. You will take care of proper disposal and recycling of the EVM's electronic components and packing materials.

Certain Instructions. It is important to operate this EVM within TI's recommended specifications and environmental considerations per the user guidelines. Exceeding the specified EVM ratings (including but not limited to input and output voltage, current, power, and environmental ranges) may cause property damage, personal injury or death. If there are questions concerning these ratings please contact a TI field representative prior to connecting interface electronics including input power and intended loads. Any loads applied outside of the specified output range may result in unintended and/or inaccurate operation and/or possible permanent damage to the EVM and/or interface electronics. Please consult the EVM User's Guide prior to connecting any load to the EVM output. If there is uncertainty as to the load specification, please contact a TI field representative. During normal operation, some circuit components may have case temperatures greater than 60°C as long as the input and output are maintained at a normal ambient operating temperature. These components include but are not limited to linear regulators, switching transistors, pass transistors, and current sense resistors which can be identified using the EVM schematic located in the EVM User's Guide. When placing measurement probes near these devices during normal operation, please be aware that these devices may be very warm to the touch. As with all electronic evaluation tools, only qualified personnel knowledgeable in electronic measurement and diagnostics normally found in development environments should use these EVMs.

Agreement to Defend, Indemnify and Hold Harmless. You agree to defend, indemnify and hold TI, its licensors and their representatives harmless from and against any and all claims, damages, losses, expenses, costs and liabilities (collectively, "Claims") arising out of or in connection with any use of the EVM that is not in accordance with the terms of the agreement. This obligation shall apply whether Claims arise under law of tort or contract or any other legal theory, and even if the EVM fails to perform as described or expected.

Safety-Critical or Life-Critical Applications. If you intend to evaluate the components for possible use in safety critical applications (such as life support) where a failure of the TI product would reasonably be expected to cause severe personal injury or death, such as devices which are classified as FDA Class III or similar classification, then you must specifically notify TI of such intent and enter into a separate Assurance and Indemnity Agreement.

Mailing Address: Texas Instruments, Post Office Box 655303, Dallas, Texas 75265
Copyright © 2012, Texas Instruments Incorporated

IMPORTANT NOTICE

Texas Instruments Incorporated and its subsidiaries (TI) reserve the right to make corrections, enhancements, improvements and other changes to its semiconductor products and services per JESD46, latest issue, and to discontinue any product or service per JESD48, latest issue. Buyers should obtain the latest relevant information before placing orders and should verify that such information is current and complete. All semiconductor products (also referred to herein as "components") are sold subject to TI's terms and conditions of sale supplied at the time of order acknowledgment.

TI warrants performance of its components to the specifications applicable at the time of sale, in accordance with the warranty in TI's terms and conditions of sale of semiconductor products. Testing and other quality control techniques are used to the extent TI deems necessary to support this warranty. Except where mandated by applicable law, testing of all parameters of each component is not necessarily performed.

TI assumes no liability for applications assistance or the design of Buyers' products. Buyers are responsible for their products and applications using TI components. To minimize the risks associated with Buyers' products and applications, Buyers should provide adequate design and operating safeguards.

TI does not warrant or represent that any license, either express or implied, is granted under any patent right, copyright, mask work right, or other intellectual property right relating to any combination, machine, or process in which TI components or services are used. Information published by TI regarding third-party products or services does not constitute a license to use such products or services or a warranty or endorsement thereof. Use of such information may require a license from a third party under the patents or other intellectual property of the third party, or a license from TI under the patents or other intellectual property of TI.

Reproduction of significant portions of TI information in TI data books or data sheets is permissible only if reproduction is without alteration and is accompanied by all associated warranties, conditions, limitations, and notices. TI is not responsible or liable for such altered documentation. Information of third parties may be subject to additional restrictions.

Resale of TI components or services with statements different from or beyond the parameters stated by TI for that component or service voids all express and any implied warranties for the associated TI component or service and is an unfair and deceptive business practice. TI is not responsible or liable for any such statements.

Buyer acknowledges and agrees that it is solely responsible for compliance with all legal, regulatory and safety-related requirements concerning its products, and any use of TI components in its applications, notwithstanding any applications-related information or support that may be provided by TI. Buyer represents and agrees that it has all the necessary expertise to create and implement safeguards which anticipate dangerous consequences of failures, monitor failures and their consequences, lessen the likelihood of failures that might cause harm and take appropriate remedial actions. Buyer will fully indemnify TI and its representatives against any damages arising out of the use of any TI components in safety-critical applications.

In some cases, TI components may be promoted specifically to facilitate safety-related applications. With such components, TI's goal is to help enable customers to design and create their own end-product solutions that meet applicable functional safety standards and requirements. Nonetheless, such components are subject to these terms.

No TI components are authorized for use in FDA Class III (or similar life-critical medical equipment) unless authorized officers of the parties have executed a special agreement specifically governing such use.

Only those TI components which TI has specifically designated as military grade or "enhanced plastic" are designed and intended for use in military/aerospace applications or environments. Buyer acknowledges and agrees that any military or aerospace use of TI components which have **not** been so designated is solely at the Buyer's risk, and that Buyer is solely responsible for compliance with all legal and regulatory requirements in connection with such use.

TI has specifically designated certain components as meeting ISO/TS16949 requirements, mainly for automotive use. In any case of use of non-designated products, TI will not be responsible for any failure to meet ISO/TS16949.

Products

Audio	www.ti.com/audio
Amplifiers	amplifier.ti.com
Data Converters	dataconverter.ti.com
DLP® Products	www.dlp.com
DSP	dsp.ti.com
Clocks and Timers	www.ti.com/clocks
Interface	interface.ti.com
Logic	logic.ti.com
Power Mgmt	power.ti.com
Microcontrollers	microcontroller.ti.com
RFID	www.ti-rfid.com
OMAP Applications Processors	www.ti.com/omap
Wireless Connectivity	www.ti.com/wirelessconnectivity

Applications

Automotive and Transportation	www.ti.com/automotive
Communications and Telecom	www.ti.com/communications
Computers and Peripherals	www.ti.com/computers
Consumer Electronics	www.ti.com/consumer-apps
Energy and Lighting	www.ti.com/energy
Industrial	www.ti.com/industrial
Medical	www.ti.com/medical
Security	www.ti.com/security
Space, Avionics and Defense	www.ti.com/space-avionics-defense
Video and Imaging	www.ti.com/video

TI E2E Community

e2e.ti.com

Looking for pricing, stock, or lifecycle information?

Click below to explore more details on WIN SOURCE:

 [View TPS43061EVM-198](#) on WIN SOURCE

 [Texas Instruments](#) Information

Optimize Your Supply Chain with WIN SOURCE Solutions

-  Global Sourcing Solution
-  Obsolete Management
-  Cost Control Management
-  Shortage Management
-  Alternative Solution
-  Excess Inventory Management