



THE DATASHEET OF TPS2376HEVM



TPS2376HEVM

This user's guide describes the characteristics, operation, and use of the TPS2376HEVM, demonstrating high-power, Power-over-Ethernet (PoE). Typical PoE applications consist of two parts:

- Power Sourcing Equipment (PSE) that injects power into the Ethernet Category 5 (CAT5) cable and
- Powered Devices (PD) that connect to the CAT5 cable to receive power.

This evaluation board demonstrates a complete PD solution including detection, classification, and current limiting required for many PoE applications and delivers an isolated 5 V at 5 A to the load.

The theory and general application of PoE is beyond the scope of this User's Guide, so for a broader description see the application material listed in the [Related Materials from Texas Instruments](#) section. This User's Guide includes setup instructions, a schematic diagram, a bill of materials (BOM) and PCB-layout drawings for the TPS2376HEVM.

Contents

1	Related Documentation From Texas Instruments.....	2
2	Introduction	2
3	Setup	2
4	Board Layout	7
5	Bill of Materials and Schematics	10

List of Figures

1	5-V Output Startup Waveform.....	4
2	TP13 Waveform, 5-V Output Ripple Voltage.....	4
3	Efficiency.....	5
4	Booster Circuit Current Distribution	5
5	Loop Gain and Phase Margin	6
6	Top-Side Layout	7
7	Bottom-Side Layout.....	8

List of Tables

1	Bill of Materials	10
---	-------------------------	----

1 Related Documentation From Texas Instruments

- TPS2376-H data sheet ([SLVS646](#))
- UCC3809-2 data sheet ([SLUS166](#))
- TPS2375 data sheet ([SLVS525](#))
- TPS2384 data sheet ([SLUS634](#))
- Application report, *High Power PoE Using TPS2375/77-1* ([SLVA225](#))
- Application report, *Achieving High Efficiency with a Multi-Output CCM Flyback Supply Using Self-Driven Synchronous Rectifiers* ([SLUP204](#))
- Application report, *Reference Design: Isolated 50W Flyback Converter Using the UCC3809 Primary Side Controller* ([SLUU096](#)).

2 Introduction

Traditionally, PoE has followed the standard IEEE 802.3af for specifying PD design and performance that includes a maximum power allotment of 15.4 W per port by the PSE. Due to resistive losses in the CAT5 cable, the effective power to the PD input is limited to approximately 13 W. Additionally, most applications require a power supply after the PD input that further reduces the system efficiency and limits actual power to the load to approximately 11 W. As the drive for more complex end equipment increases, many end equipment types requires more power than the IEEE 802.3af standard allows. This evaluation board demonstrates how a PD can deliver up to 25 W to the load, and can be interfaced to any PSE that follows detection and classification procedures defined by the IEEE 802.3af standard. For details on PD operation, read the Application Information section in the datasheet for the TPS2375, *IEEE 802.3af PoE Powered Device Controllers* ([SLVS525](#)). For details on PSE operation, read the Application Information section in the data sheet for the TPS2384, *Quad Integrated Power Sourcing Equipment Power Manager* ([SLUS634](#)).

Note that from a system-level perspective, the amount of power that can be delivered to the load is dependent on both the PD and PSE. This evaluation board is intended to demonstrate how a PD can deliver 25 W to the load. Because this PD evaluation board is intended for power levels greater than what the IEEE 802.3af specification allows, a PSE designed to meet only the IEEE 802.3af standard will not be able to source enough power, because it will go into current limit once the port current goes higher than 350 mA. For additional details, read the application report, *High Power PoE Using TPS2375/77-1* ([SLVA225](#)).

The DC/DC power supply used in this evaluation board uses a Continuous Conduction Mode Synchronous Flyback topology using the UCC3809-2 Economy Primary Side Controller. For details on this topology, see the application reports, *Achieving High Efficiency with a Multi-Output CCM Flyback Supply Using Self-Driven Synchronous Rectifiers* ([SLUP204](#)) and, *Reference Design: Isolated 50 W Flyback Converter Using the UCC3809 Primary Side Controller* ([SLUU096](#)). For details on the UCC3809, see the data sheet ([SLUS166](#)).

3 Setup

3.1 Input / Output Connector Descriptions

This section describes the jumpers and connectors on the TPS2376HEVM EVM as well as how to properly connect, setup, and use TPS2376HEVM.

3.1.1 J1 – Data Port Output

J1 is the RJ-45 adapter jack for the Data Port output for Ethernet data transmission. CAT5 cable can be connected here to transmit Gigabit Ethernet data; however, this is beyond the scope of this reference design and does not have any bearing on the PoE functionality. For PoE operation, J1 is not used.

3.1.2 J2 – Ethernet Power

J2 is the RJ-45 adapter jack for connecting Ethernet Power to the evaluation board. Plug in the CAT5 cable from the PSE here to deliver power to the board. Only apply power to either J3 or J4 at one time; never apply power at both J3 and J4 at the same time. When applying power at J2, place the shorting jumper on J5 for proper operation.

3.1.3 J3 – DC/DC Input Power

In some cases it is beneficial to test the DC/DC power supply without using the front-end PD. J3 is the power connector used when testing the DC/DC power supply without the front-end PD functionality. Apply +48 V to the TP1 side of the header, and connect the return GND path to the TP2 side. Only apply power to either J3 or J4 at one time; never apply power at both J3 and J4 at the same time. While applying power at J3, remove the shorting jumper on J5 to ensure proper functionality.

3.1.4 J4 – 5V Output Power

J4 is the 5-V output of the DC/DC power supply. Connect a load between the two terminals of this header. The positive polarity is closest to TP5, and the negative polarity is closest to TP9.

3.1.5 J5 – Powered-Device DC/DC Disconnect

This jumper connects the PG output of the TPS2376-H to the timing capacitor of the UCC3809-2. Holding this node low disables the UCC3809-2 and prevents the 5-V output from turning on. When applying power at J2 and testing the PD functionality of this board, place the shorting jumper on J5 so that the power supply is disabled until the PG signal of the TPS2376-H is released. When applying power at J3 and testing only the DC/DC power supply without PD functionality, remove this shorting jumper.

3.2 Electrical Specifications

PARAMETER	CONDITION	MIN	TYP	MAX	UNIT
POWER INTERFACE					
Input voltage, V_{IN}	Applied to the power pins of connectors J2 or J3	0		57	V
Operating voltage	After startup	41		57	V
Input UVLO	Rising input voltage			40.5	V
	Falling input voltage	29			V
Detection voltage		1.4		10.1	V
Classification voltage		10.2		23	V
Classification current		2.2	2.4	2.8	mA
DC/DC CONVERTER					
Output voltage	$41\text{ V} < V_{IN} < 57\text{ V}$, Up to full load	4.75	5	5.25	V
Output current	$41\text{ V} < V_{IN} < 57\text{ V}$			5	A
Output ripple voltage, peak-to-peak	$V_{IN} = 48\text{ V}$, Load = 5 A		50		mV
Efficiency, end-to-end	$V_{IN} = 48\text{ V}$, Load = 3 A		83%		
Switching frequency		270		330	kHz

3.3 Test Results

The test results for this EVM at $T_A = 25^\circ\text{C}$ follow.

Figure 1 shows the 5-V output startup waveform at J4 (Bottom, 2 V/div) after the application of 48 Vdc at J3 (Top, 20 V/div). The output at J4 was loaded to 0 A (500 ms / div).

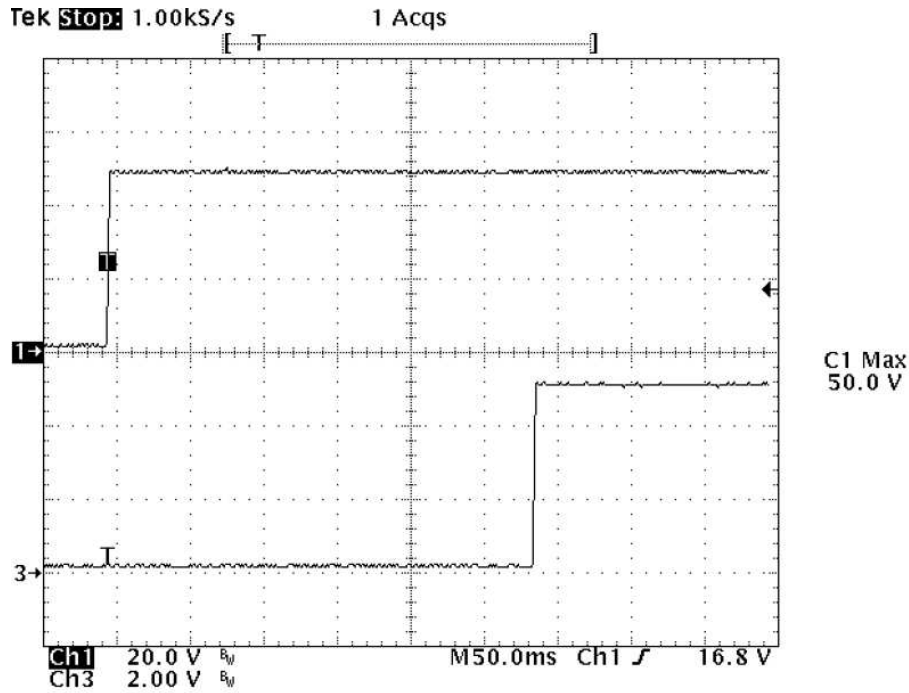

Figure 1. 5-V Output Startup Waveform

The waveform at TP13 on the drain of the primary side FET (Top, 50 V/div) and the 5 V output ripple voltage at J4 (Bottom, 50 mV/div) are shown in the figures below. The images were taken with the output loaded to 5 A at J4 and the input voltage set to 48 Vdc at J3 (2 μs /div).

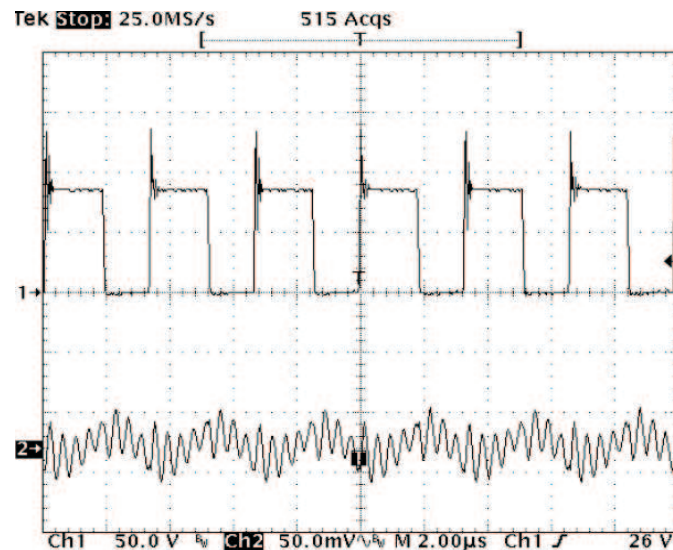

Figure 2. TP13 Waveform, 5-V Output Ripple Voltage

The converter efficiency and regulation over load are shown in Figure 3. Two conditions are shown; 1) 48 V is applied at J2 and 2) 48 V is applied at J3.

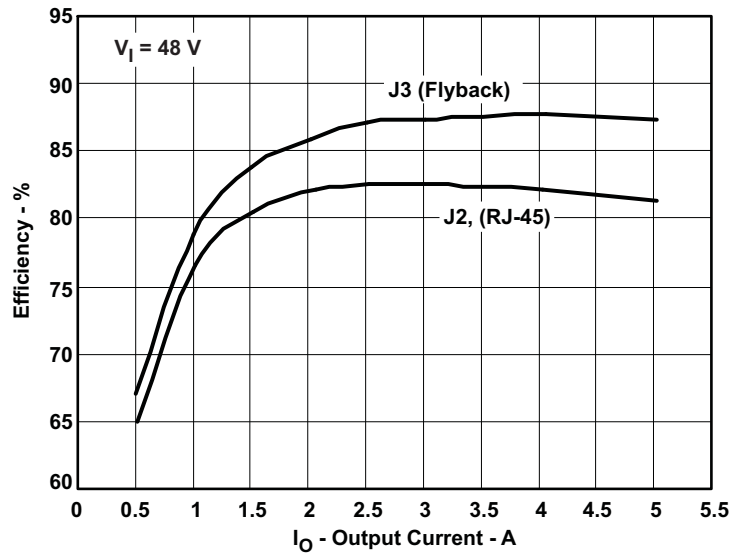

Figure 3. Efficiency

To avoid current limiting at the TPS2376-H PD, a current booster circuit composed of Q1, Q2, R15, and R19 is used to create a secondary return path for the input current. Figure 4 shows the current distribution between the two paths. Detailed explanation on this circuit is provided in the TI application report, *High-Power PoE Using TPS2375/77-1* ([SLVA225](#)).

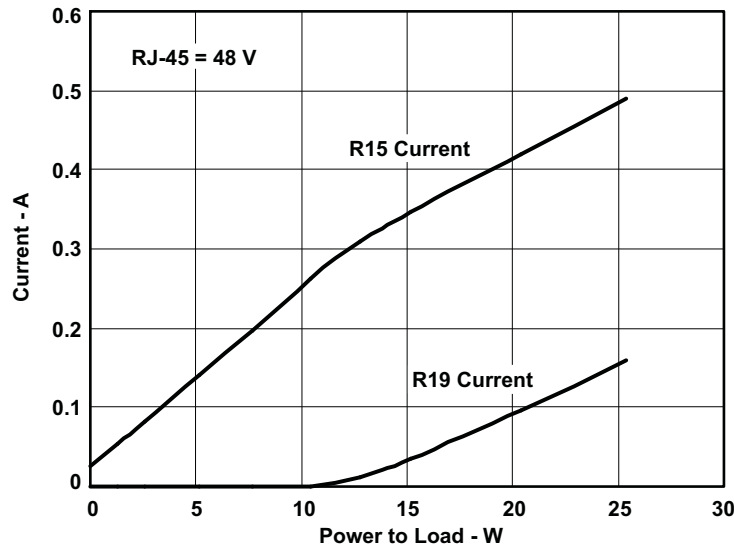

Figure 4. Booster Circuit Current Distribution

Setup

Figure 5 shows the loop gain and phase margin with input voltage set to 48 V at J3. The output was loaded to 5 A at J4. Bandwidth ≈ 3.19 kHz, Phase Margin $\approx 75.3^\circ$.

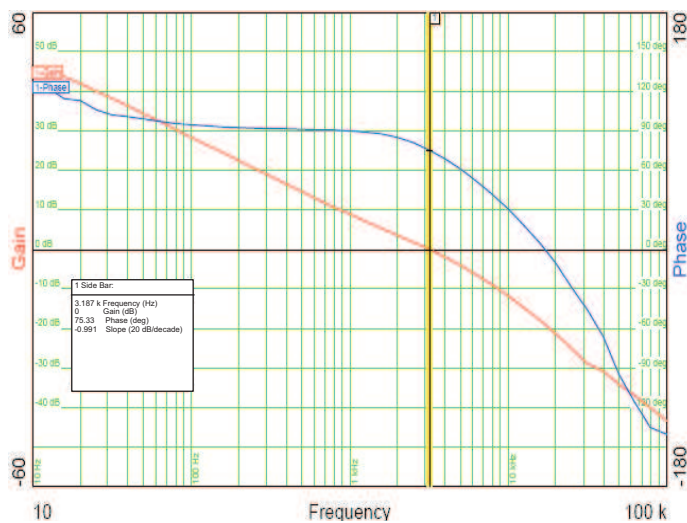

Figure 5. Loop Gain and Phase Margin

4 Board Layout

This section provides the TPS2376HEVM board layout and illustrations.

4.1 Layout

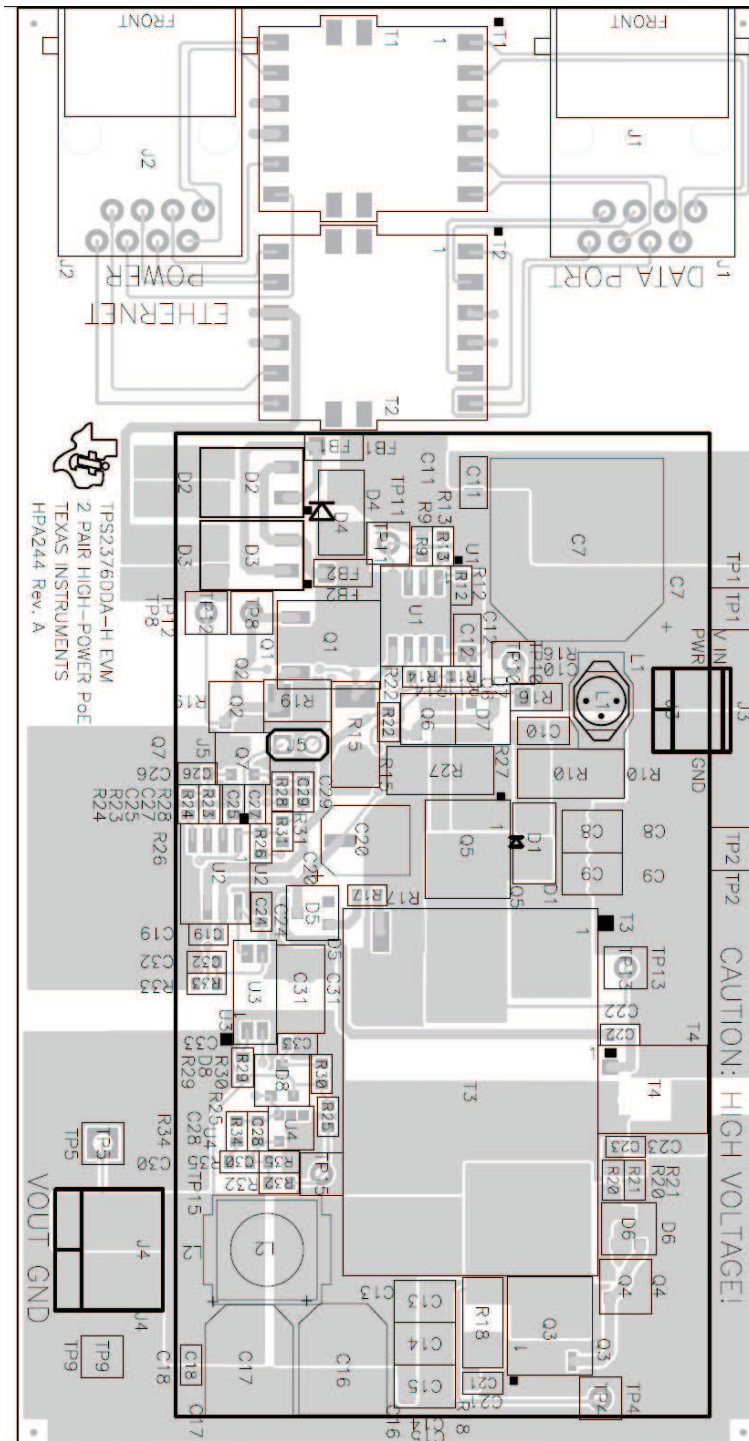

Figure 6. Top-Side Layout

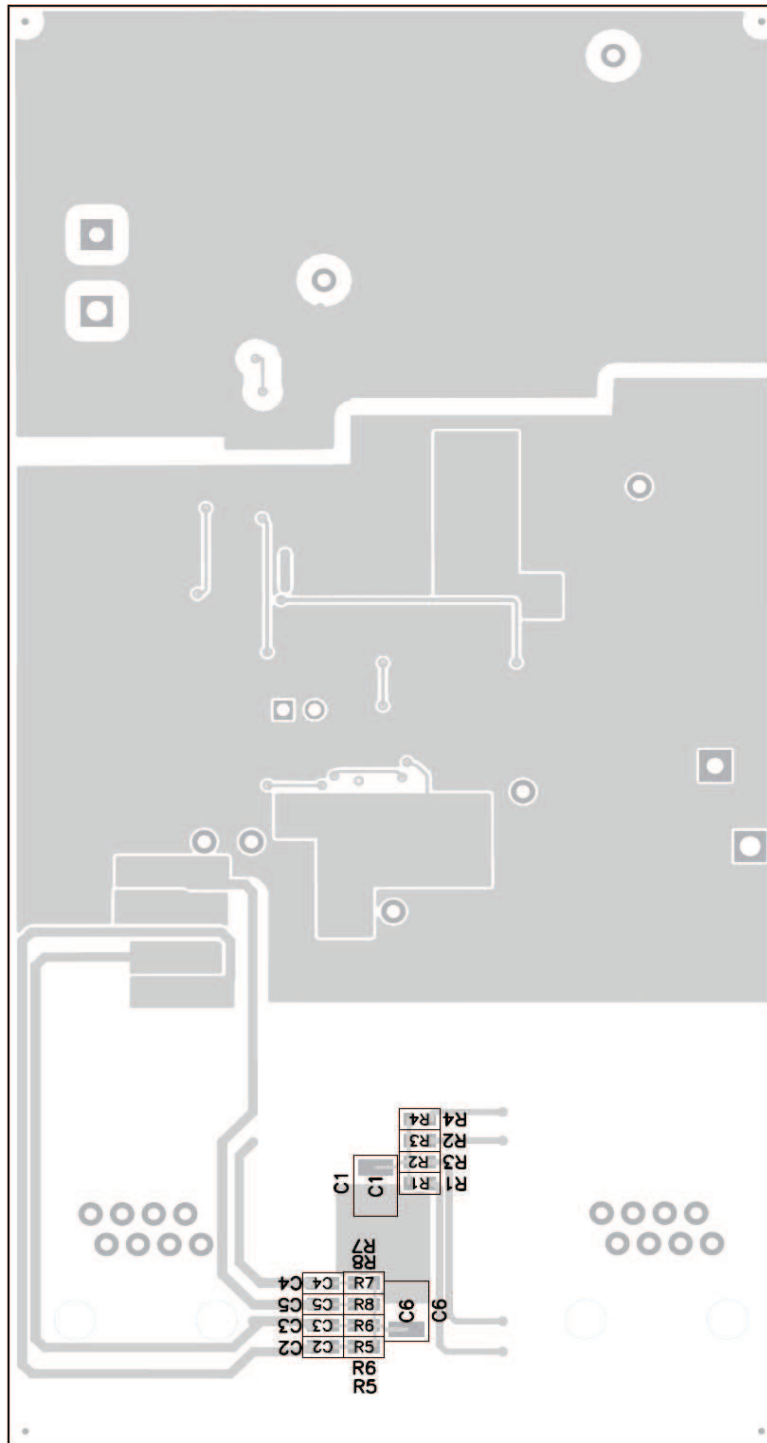

Figure 7. Bottom-Side Layout

4.2 Layout Considerations

The layout of the PoE front end must use good practices for power and EMI/ESD. A basic set of recommendations include:

- The parts placement must be arranged by the power flow in a point-to-point manner such as RJ-45 → Ethernet transformer → diode bridges → TVS and 0.1- μ F capacitor → TPS2376-H → bulk capacitor → DC/DC power supply.
- Avoid crossovers of signals from one part of the flow to another.
- Keep all leads as short as possible, with wide power traces and paired signal and return paths.
- Spacing consistent with safety standards like IEC60950 must be observed between the 48-V input voltage rails, and between the input and an isolated converter output.
- The TPS2376-H should be referenced to a local ground plane V_{SS} . The UCC3809-2 should be referenced to a local ground plane RTN.
- Large copper fills and traces should be used on SMT power-dissipating devices, and wide traces or overlay copper fills should be used in the power path.

Converter layout benefits from basic rules such as:

1. Pair signals to reduce emissions and noise, especially the paths that carry high-current pulses, including the power semiconductors and magnetics.
2. Minimize the length of all the traces in step 1.
3. Where possible, use vertical pairing.
4. Use care if using the ground plane for the switching currents.
5. Keep the high-current and high-voltage switching paths away from low-level sensing circuits, including those outside the power supply.
6. Pay special attention to spacing around the high-voltage sections of the converter.

5 Bill of Materials and Schematics

This section provides the TPS2376HEVM bill of materials and schematics.

5.1 Bill of Materials

Table 1. Bill of Materials

Count	RefDes	Value	Description	Size	Part Number	MFR
2	C1, C6	1000 pF	Capacitor, Ceramic, 2 kV, X7R, 10%	1210	Std	TDK
3	C10, C11, C12	0.1 µF	Capacitor, Ceramic, 100 V, X7R, 10%	0805	Std	TDK
3	C13, C14, C15	47 µF	Capacitor, Ceramic, 10 V, X5R, 15%	1210	Std	TDK
2	C16, C17	220 µF	Capacitor, Aluminum, 6.3 V, ±20%	0.260 × 0.276 inch	EEVFK0J221P	Panasonic
3	C18, C24, C33	1 µF	Capacitor, Ceramic, 16 V, X7R, 10%	0603	Std	TDK
1	C19	0.22 µF	Capacitor, Ceramic, 25 V, X7R, 10%	0603	Std	TDK
4	C2, C3, C4, C5	0.01 µF	Capacitor, Ceramic, 100 V, X7R, 10%	0603	Std	TDK
1	C20	22 µF	Capacitor, Aluminum, 25 V, ±20%	0.201 × 0.262 inch	EEVFK1E220R	Panasonic
1	C21	1000 pF	Capacitor, Ceramic, 50 V, X7R, 10%	0603	Std	TDK
2	C22, C23	0.47 µF	Capacitor, Ceramic, 25 V, X7R, 10%	0805	Std	TDK
1	C25	0.01 µF	Capacitor, Ceramic, 50 V, X7R, 10%	0603	Std	TDK
1	C26	270 pF	Capacitor, Ceramic, 50 V, X7R, 10%	0603	Std	TDK
1	C27	100 pF	Capacitor, Ceramic, 50 V, X7R, 10%	0603	Std	TDK
0	C28	Not Used	Capacitor, Ceramic, 50 V, X7R, 10%	0603	Std	TDK
1	C29	0.1 µF	Capacitor, Ceramic, 25 V, X7R, 10%	0603	Std	TDK
1	C30	1200 pF	Capacitor, Ceramic, 50 V, X7R, 10%	0603	Std	TDK
1	C31	2200 pF	Capacitor, Ceramic, 2 kV, X7R, 10%	1812	Std	TDK
1	C32	0.082 µF	Capacitor, Ceramic, 50 V, X7R, 10%	0603	Std	TDK
1	C7	47 µF	Capacitor, Aluminum, 100 V, 20%	0.543 × 0.543	EEVFK2A470Q	Panasonic
2	C8, C9	1 µF	Capacitor, Ceramic, 100 V, X7R, 10%	1210	Std	Vishay
1	D1	MURA120	Diode, Rectifier, 1 A, 200 V	SMA	MURA120	On Semi
2	D2, D3	HD01-T	Bridge Rectifier, 400 V, 0.8 A, Glass Passivated, SMD	MINI DIP4	HD01-T	Diodes, Inc.
1	D4	SMAJ58A	Diode, SMT TVS 400 W, 4.3-A, 58-V	SMA	SMAJ58A	Diodes
2	D5, D7	BAS16	Diode, Switching, 150-mA, 75-V, 350 mW	SOT23	BAS16	Vishay-Liteon
2	D6, D8	BAV99	Diode, Dual Ultra Fast, Series, 200-mA, 70-V	SOT23	BAV99	Fairchild
2	FB1, FB2		Bead, Ferrite, SMT	0805	MI0805K110R-10 or MMZ2012R150A	Steward or TDK
2	J1, J2	520252-4	Connector, Jack, Modular, 8 POS	0.705 × 0.820 inch	520252-4	AMP
1	J3	ED1514	Terminal Block, 2-pin, 6-A, 3.5 mm	0.27 × 0.25 inch	ED1514	OST
1	J4	ED1609-ND	Terminal Block, 2-pin, 15-A, 5.1 mm	0.40 × 0.35 inch	ED1609	OST
1	L1	3.3 µH	Inductor, SMT, 2A, 80 mΩ	0.26 × 0.09 inch	DO1608-332	Coilcraft
1	L2	0.33 µH	Inductor, SMT, 6.26A, 7.4 mΩ	0.300 sq"	DR74-R33	Coiltronics
1	Q1	BCP53T1	Bipolar, PNP, 100-V, 1.5-A, 1.5-W	SOT-223	BCP53T1	On Semi
1	Q2	MMBT2907ALT1	Transistor, PNP, -60V, -600mA, 225-W	SOT23	MMBT2907ALT1	On Semi
1	Q3	Si7848DP	MOSFET, NChannel, 60V, 15.8 A, 11 mΩ	PWRPAK S0-8	Si7848DP	Vishay-Siliconix
3	Q4, Q6, Q7	MMBT3906	Bipolar, PNP, 40-V, 200-mA, 222-mW	SOT23	MMBT3906LT1	On Semi
1	Q5	Si7450DP	MOSFET, NChannel, 200 V, 5.3 A, 90 mΩ	PWRPAK S0-8	Si7450DP	Vishay-Siliconix
8	R1-R8	75 Ω	Resistor, Chip, 1/16 W, 1%	0603	Std	Std
1	R10	15 kΩ	Resistor, Chip, 1 W, 1%	2512	Std	Std
1	R11	909 kΩ	Resistor, Chip, 1/16 W, 1%	0603	Std	Std
1	R12	357 kΩ	Resistor, Chip, 1/16 W, 1%	0603	Std	Std
1	R13	4.42 kΩ	Resistor, Chip, 1/16W, 1%	0603	Std	Std

Table 1. Bill of Materials (continued)

Count	RefDes	Value	Description	Size	Part Number	MFR
1	R14	61.9 kΩ	Resistor, Chip, 1/16 W, 1%	0603	Std	Std
1	R15	2.2 Ω	Resistor, Chip, 1 W, 1%	2512	Std	Std
1	R16	30.1 kΩ	Resistor, Chip, 1/10 W, 1%	0805	Std	Std
1	R17	20 Ω	Resistor, Chip, 1/16 W, 1%	0603	Std	Std
1	R18	10 Ω	Resistor, Chip, 1/2 W, 1%	2010	Std	Std
1	R19	2.2 Ω	Resistor, Chip, 1/4 W, 1%	1210	Std	Std
2	R20, R25	49.9 Ω	Resistor, Chip, 1/16 W, 1%	0603	Std	Std
3	R21, R30, R31	10 kΩ	Resistor, Chip, 1/16 W, 1%	0603	Std	Std
1	R22	24.9 Ω	Resistor, Chip, 1/16 W, 1%	0603	Std	Std
1	R23	10.7 kΩ	Resistor, Chip, 1/16 W, 1%	0603	Std	Std
1	R24	4.64 kΩ	Resistor, Chip, 1/16 W, 1%	0603	Std	Std
3	R26, r29, R33	1 kΩ	Resistor, Chip, 1/16 W, 1%	0603	Std	Std
1	R27	0.33 Ω	Resistor, Chip, 1 W, 1%	2512	Std	Std
1	R28	4.99 kΩ	Resistor, Chip, 1/16 W, 1%	0603	Std	Std
2	R32, R34	41.2 kΩ	Resistor, Chip, 1/16 W, 1%	0603	Std	Std
1	R35	13.3 kΩ	Resistor, Chip, 1/16 W, 1%	0603	Std	Std
1	R9	25.5 kΩ	Resistor, Chip, 1/16 W, 1%	0603	Std	Std
2	T1, T2	ETH1-230LD	XFMR, Mid-Power PoE Magnetics	S0 14 Wide	ETH1-230LD	Coilcraft
1	T3	POE300F-50L	Transformer, SMT for PoE/PD, xW, zzA	0810 × 1.181 inch	POE300F-50L	Coilcraft
1	T4	330 μH	Transformer, Driver, 330 μH Ip, 1500V insulation	0.210 × 0.210 inch	P0926	Pulse
3	TP1, TP5, TP9	5012	Test Point, White, Thru Hole	0.125 × 0.125 inch	5012	Keystone
1	J5		Header 1x2 100 mils	TH	TH	Std
2	TP2, TP11	5001	Test Point, Black, Thru Hole Color Keyed	0.100 × 0.100 inch	5001	Keystone
6	TP4, TP8, TP10, TP12, TP13, TP15	5000	Test Point, Red, Thru Hole Color Keyed	0.100 × 0.100 inch	5000	Keystone
1	U1	TPS2376DDA-H	IC, IEEE 802.3af Power Device Controller	S0-8 PowerPAD™	TPS2376DDA-H	TI
1	U2	UCC3809D2	IC, Economy Primary-Side Controller, xx-V startup	S08	UCC3809D-2	TI
1	U3	TCMT1107	IC< Photocoupler	MF4	TCMT1107	Vishay
1	U4	TLV431ACDBVR	IC, Shunt Regulator, 1.24-V ref, 6-V, 10-mA, 1%	SOT23-5	TLV431ACDBVR	TI
1	NA	NA	PCB, 2-Layer, 4.75" × 2.440" × 0.062"		HPA244	Any
1	NA	NA	Shunt		STC02SYAN	Sullins
4	NA	NA	Rubber Bumper		2563	SPC Technology

- Notes: 1 These assemblies are ESD sensitive, ESD precautions shall be observed.
2. These assemblies must be clean and free from flux and all contaminants. Use of no clean flux is not acceptable.
3. These assemblies must comply with workmanship standards IPC-A-610 Class 2.
4. Ref designators marked with an asterisk (**) cannot be substituted. All other components can be substituted with equivalent MFG's components.
5. Bumpers, to be installed on bottom of PCB, at four corners, of four sides, and approximate center of board.

5.2 Schematics

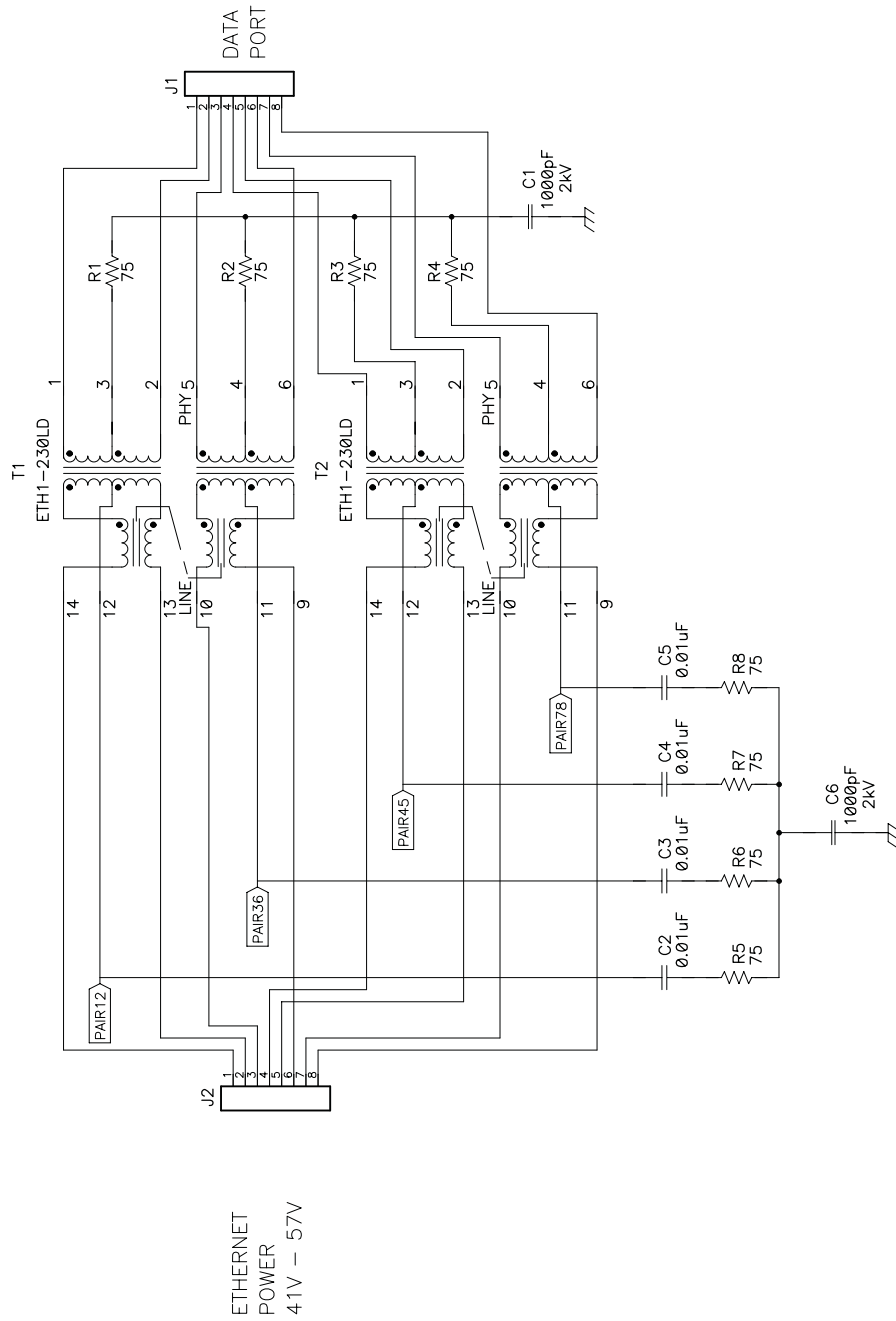

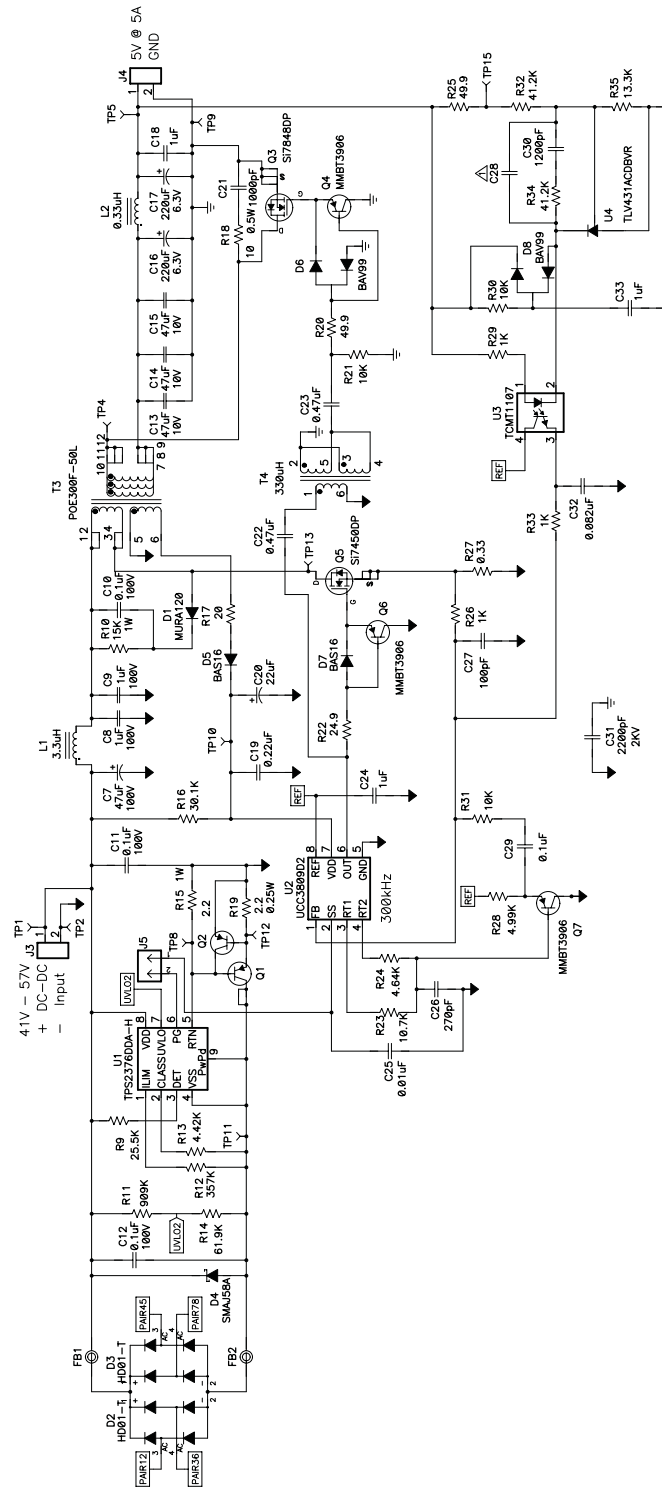

△ NOT USED

EVM WARNINGS AND RESTRICTIONS

It is important to operate this EVM within the input voltage range of 0 V to 57 V and the output voltage range of 4.75 V to 5.25 V.

Exceeding the specified input range may cause unexpected operation and/or irreversible damage to the EVM. If there are questions concerning the input range, please contact a TI field representative prior to connecting the input power.

Applying loads outside of the specified output range may result in unintended operation and/or possible permanent damage to the EVM. Please consult the EVM User's Guide prior to connecting any load to the EVM output. If there is uncertainty as to the load specification, please contact a TI field representative.

During normal operation, some circuit components may have case temperatures greater than 70°C. The EVM is designed to operate properly with certain components above 70°C as long as the input and output ranges are maintained. These components include but are not limited to linear regulators, switching transistors, pass transistors, and current sense resistors. These types of devices can be identified using the EVM schematic located in the EVM User's Guide. When placing measurement probes near these devices during operation, please be aware that these devices may be very warm to the touch.

Mailing Address: Texas Instruments, Post Office Box 655303, Dallas, Texas 75265
Copyright © 2007, Texas Instruments Incorporated

EVALUATION BOARD/KIT IMPORTANT NOTICE

Texas Instruments (TI) provides the enclosed product(s) under the following conditions:

This evaluation board/kit is intended for use for **ENGINEERING DEVELOPMENT, DEMONSTRATION, OR EVALUATION PURPOSES ONLY** and is not considered by TI to be a finished end-product fit for general consumer use. Persons handling the product(s) must have electronics training and observe good engineering practice standards. As such, the goods being provided are not intended to be complete in terms of required design-, marketing-, and/or manufacturing-related protective considerations, including product safety and environmental measures typically found in end products that incorporate such semiconductor components or circuit boards. This evaluation board/kit does not fall within the scope of the European Union directives regarding electromagnetic compatibility, restricted substances (RoHS), recycling (WEEE), FCC, CE or UL, and therefore may not meet the technical requirements of these directives or other related directives.

Should this evaluation board/kit not meet the specifications indicated in the User's Guide, the board/kit may be returned within 30 days from the date of delivery for a full refund. **THE FOREGOING WARRANTY IS THE EXCLUSIVE WARRANTY MADE BY SELLER TO BUYER AND IS IN LIEU OF ALL OTHER WARRANTIES, EXPRESSED, IMPLIED, OR STATUTORY, INCLUDING ANY WARRANTY OF MERCHANTABILITY OR FITNESS FOR ANY PARTICULAR PURPOSE.**

The user assumes all responsibility and liability for proper and safe handling of the goods. Further, the user indemnifies TI from all claims arising from the handling or use of the goods. Due to the open construction of the product, it is the user's responsibility to take any and all appropriate precautions with regard to electrostatic discharge.

EXCEPT TO THE EXTENT OF THE INDEMNITY SET FORTH ABOVE, NEITHER PARTY SHALL BE LIABLE TO THE OTHER FOR ANY INDIRECT, SPECIAL, INCIDENTAL, OR CONSEQUENTIAL DAMAGES.

TI currently deals with a variety of customers for products, and therefore our arrangement with the user **is not exclusive**.

TI assumes **no liability for applications assistance, customer product design, software performance, or infringement of patents or services described herein**.

Please read the User's Guide and, specifically, the Warnings and Restrictions notice in the User's Guide prior to handling the product. This notice contains important safety information about temperatures and voltages. For additional information on TI's environmental and/or safety programs, please contact the TI application engineer or visit www.ti.com/esh.

No license is granted under any patent right or other intellectual property right of TI covering or relating to any machine, process, or combination in which such TI products or services might be or are used.

FCC Warning

This evaluation board/kit is intended for use for **ENGINEERING DEVELOPMENT, DEMONSTRATION, OR EVALUATION PURPOSES ONLY** and is not considered by TI to be a finished end-product fit for general consumer use. It generates, uses, and can radiate radio frequency energy and has not been tested for compliance with the limits of computing devices pursuant to part 15 of FCC rules, which are designed to provide reasonable protection against radio frequency interference. Operation of this equipment in other environments may cause interference with radio communications, in which case the user at his own expense will be required to take whatever measures may be required to correct this interference.

Mailing Address: Texas Instruments, Post Office Box 655303, Dallas, Texas 75265
Copyright © 2007, Texas Instruments Incorporated

IMPORTANT NOTICE

Texas Instruments Incorporated and its subsidiaries (TI) reserve the right to make corrections, modifications, enhancements, improvements, and other changes to its products and services at any time and to discontinue any product or service without notice. Customers should obtain the latest relevant information before placing orders and should verify that such information is current and complete. All products are sold subject to TI's terms and conditions of sale supplied at the time of order acknowledgment.

TI warrants performance of its hardware products to the specifications applicable at the time of sale in accordance with TI's standard warranty. Testing and other quality control techniques are used to the extent TI deems necessary to support this warranty. Except where mandated by government requirements, testing of all parameters of each product is not necessarily performed.

TI assumes no liability for applications assistance or customer product design. Customers are responsible for their products and applications using TI components. To minimize the risks associated with customer products and applications, customers should provide adequate design and operating safeguards.

TI does not warrant or represent that any license, either express or implied, is granted under any TI patent right, copyright, mask work right, or other TI intellectual property right relating to any combination, machine, or process in which TI products or services are used. Information published by TI regarding third-party products or services does not constitute a license from TI to use such products or services or a warranty or endorsement thereof. Use of such information may require a license from a third party under the patents or other intellectual property of the third party, or a license from TI under the patents or other intellectual property of TI.

Reproduction of TI information in TI data books or data sheets is permissible only if reproduction is without alteration and is accompanied by all associated warranties, conditions, limitations, and notices. Reproduction of this information with alteration is an unfair and deceptive business practice. TI is not responsible or liable for such altered documentation. Information of third parties may be subject to additional restrictions.

Resale of TI products or services with statements different from or beyond the parameters stated by TI for that product or service voids all express and any implied warranties for the associated TI product or service and is an unfair and deceptive business practice. TI is not responsible or liable for any such statements.

TI products are not authorized for use in safety-critical applications (such as life support) where a failure of the TI product would reasonably be expected to cause severe personal injury or death, unless officers of the parties have executed an agreement specifically governing such use. Buyers represent that they have all necessary expertise in the safety and regulatory ramifications of their applications, and acknowledge and agree that they are solely responsible for all legal, regulatory and safety-related requirements concerning their products and any use of TI products in such safety-critical applications, notwithstanding any applications-related information or support that may be provided by TI. Further, Buyers must fully indemnify TI and its representatives against any damages arising out of the use of TI products in such safety-critical applications.

TI products are neither designed nor intended for use in military/aerospace applications or environments unless the TI products are specifically designated by TI as military-grade or "enhanced plastic." Only products designated by TI as military-grade meet military specifications. Buyers acknowledge and agree that any such use of TI products which TI has not designated as military-grade is solely at the Buyer's risk, and that they are solely responsible for compliance with all legal and regulatory requirements in connection with such use.

TI products are neither designed nor intended for use in automotive applications or environments unless the specific TI products are designated by TI as compliant with ISO/TS 16949 requirements. Buyers acknowledge and agree that, if they use any non-designated products in automotive applications, TI will not be responsible for any failure to meet such requirements.

Following are URLs where you can obtain information on other Texas Instruments products and application solutions:

Products		Applications	
Amplifiers	amplifier.ti.com	Audio	www.ti.com/audio
Data Converters	dataconverter.ti.com	Automotive	www.ti.com/automotive
DSP	dsp.ti.com	Broadband	www.ti.com/broadband
Interface	interface.ti.com	Digital Control	www.ti.com/digitalcontrol
Logic	logic.ti.com	Military	www.ti.com/military
Power Mgmt	power.ti.com	Optical Networking	www.ti.com/opticalnetwork
Microcontrollers	microcontroller.ti.com	Security	www.ti.com/security
RFID	www.ti-rfid.com	Telephony	www.ti.com/telephony
Low Power Wireless	www.ti.com/lpw	Video & Imaging	www.ti.com/video
		Wireless	www.ti.com/wireless

Mailing Address: Texas Instruments, Post Office Box 655303, Dallas, Texas 75265
Copyright © 2007, Texas Instruments Incorporated

Looking for pricing, stock, or lifecycle information?

Click below to explore more details on WIN SOURCE:

 [View TPS2376HEVM on WIN SOURCE](#)

 [Texas Instruments](#) Information

Optimize Your Supply Chain with WIN SOURCE Solutions

-  Global Sourcing Solution
-  Obsolete Management
-  Cost Control Management
-  Shortage Management
-  Alternative Solution
-  Excess Inventory Management